

5/14/99

PROJECT TYPICAL DETAILS

PROJECT REFERENCE NO. B-4931	SHEET NO. UC-3B
DESIGNED BY: DK	
DRAWN BY: CS	
CHECKED BY: MM	
APPROVED BY:	
REVISED:	
NORTH CAROLINA DEPARTMENT OF TRANSPORTATION 3/6/2020	
UTILITIES ENGINEERING SEC. PHONE: (919) 707-6690 FAX: (919) 250-4151	UTILITY CONSTRUCTION PLANS ONLY
Engineers • Planners • Scientists • Construction Managers 4509 Falls of Neuse Road, Suite 400 Raleigh, NC 27609 Phone (919) 783-9214 • Fax (919) 783-9266 License No. C-764	

UTILITY CONSTRUCTION

DOCUMENT NOT CONSIDERED FINAL
UNLESS ALL SIGNATURES COMPLETED

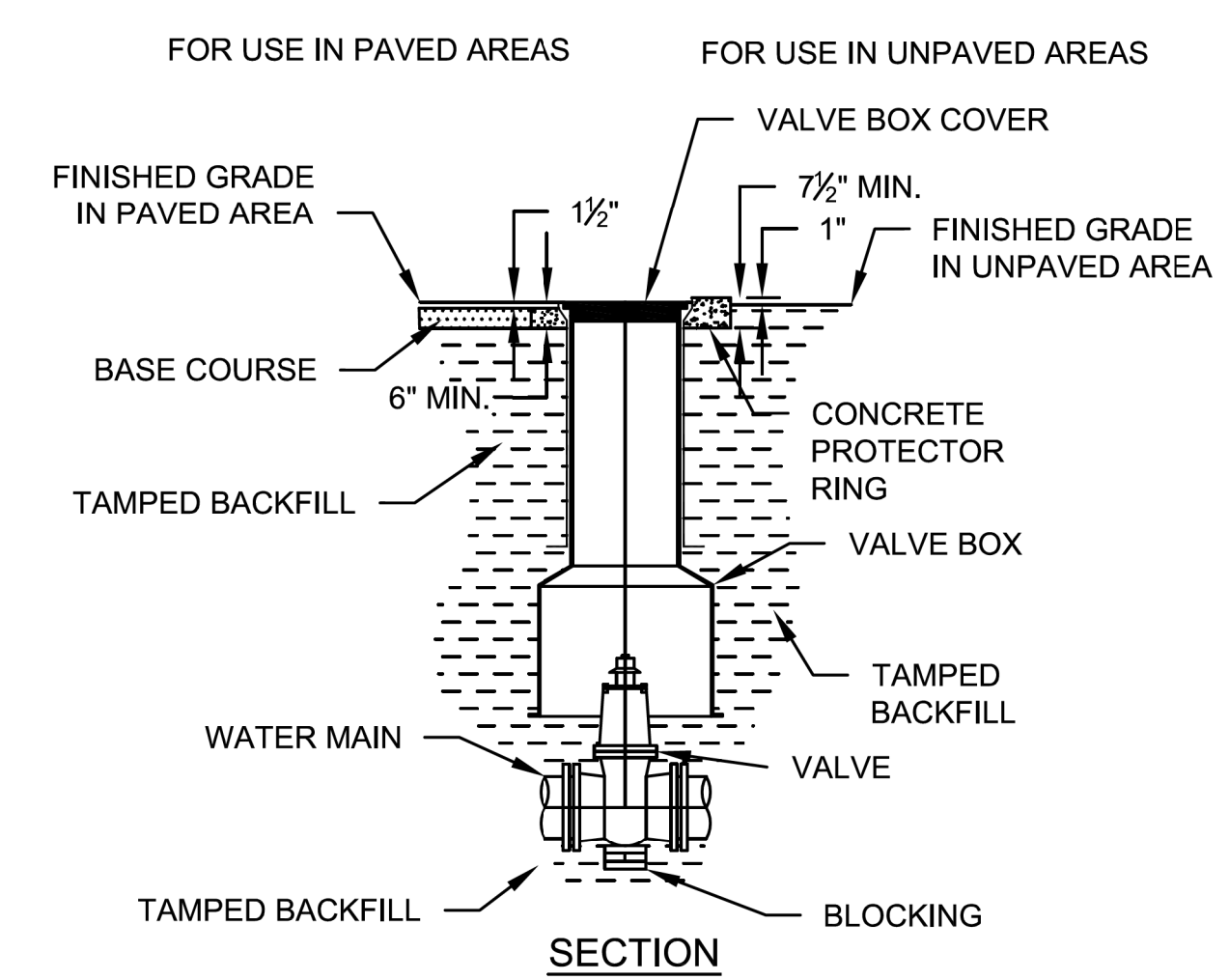

- NOTES:
1. D.I.P. MAY BE USED FOR VALVE BOX EXTENSIONS.
 2. VALVE BOX SHOULD NOT CONTACT WATER MAIN OR VALVE.
 3. CONCRETE PROTECTOR RING SHALL BE USED IN ALL UNPAVED AREAS.
 4. ALL MATERIALS USED IN THE POTABLE WATER SYSTEM MUST BE NSF61 AND NSF372 CERTIFIED AND MEET THE LATEST FEDERAL SAFE DRINKING WATER ACT REQUIREMENTS.

VALVE AND VALVE BOX INSTALLATION

NOT TO SCALE

- NOTES:
1. VALVE MARKERS SHALL BE PLACED AT R/W.
 2. LETTERS "MV" SHALL FACE TOWARDS VALVE.
 3. MARKER SHALL HAVE BRASS OR BRONZE EMBED ON TOP OR SIDE.
 4. CONTRACTOR SHALL STAMP DISTANCE TO CENTER OF VALVE INTO EMBED.
 5. BLOW-OFF ASSEMBLY SHALL INCLUDE 1 EA. MARKER W/ "BO" OR "MV" CAST.

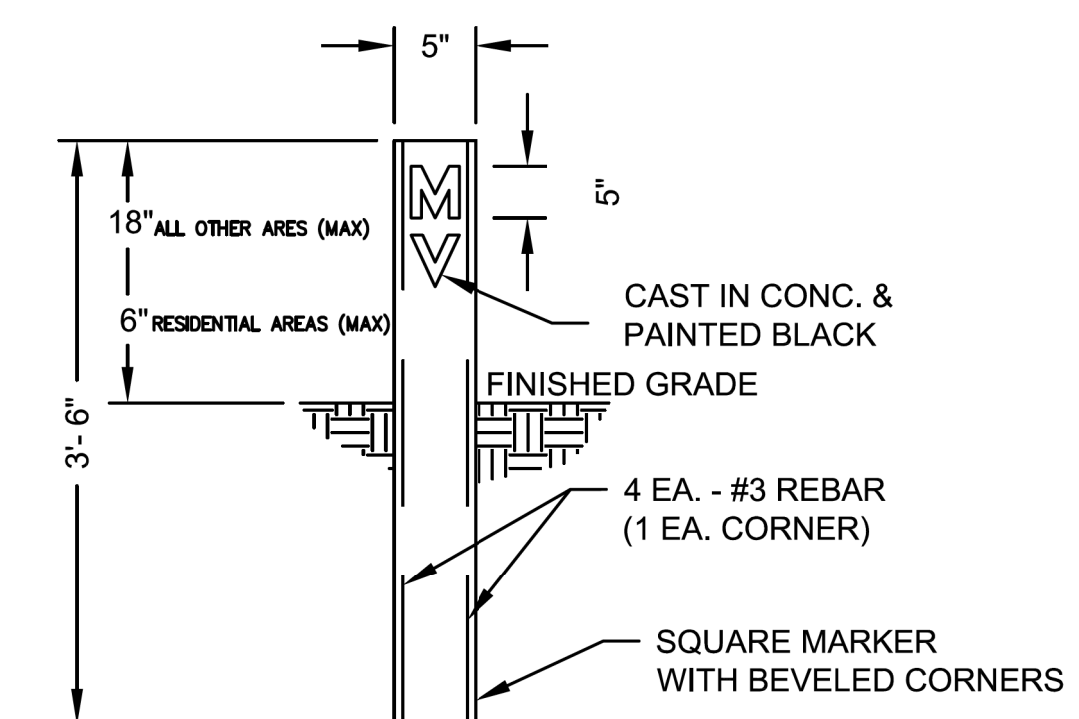

VALVE MARKER DETAIL

NOT TO SCALE

03 MAR 2020 14:54
C:\Users\jmc\OneDrive\Documents\B-4931.dtl\UC03B.dgn