

NOTE: SEE RSD 1101.01 SHEET 3 OF 3 FOR ADVANCED WARNING SIGNS AND SPACING

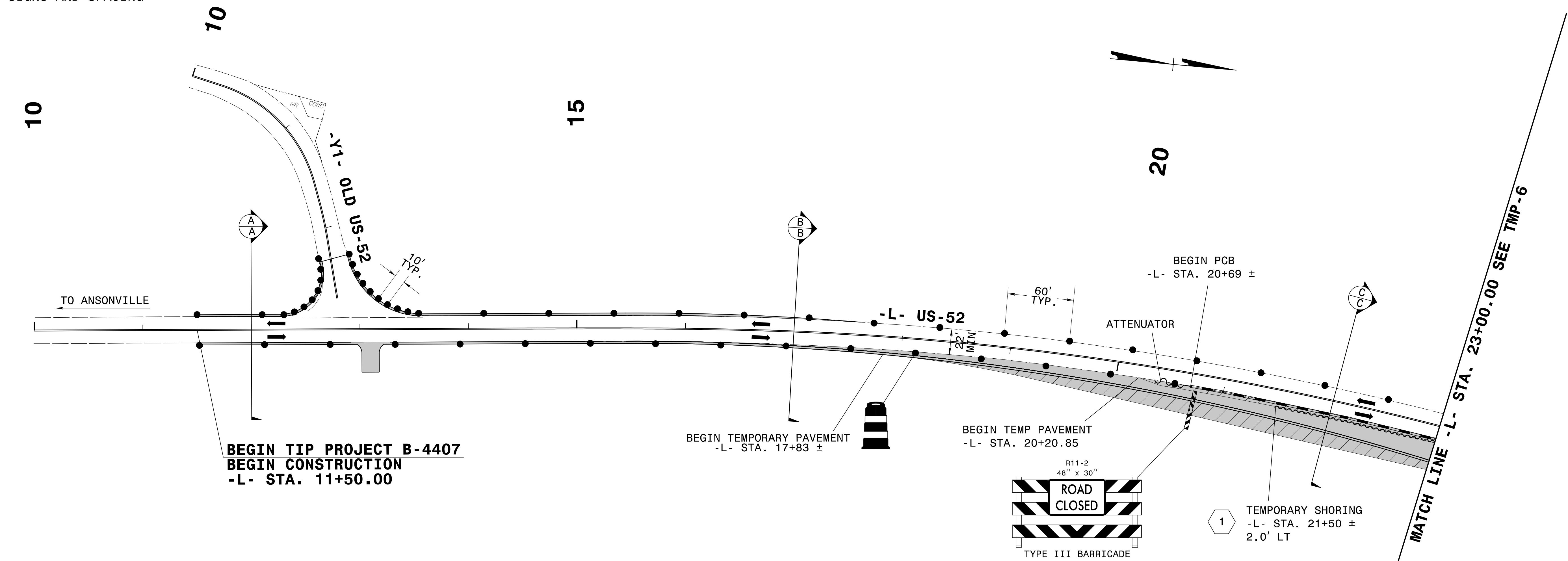

### SECTION A-A

12+00

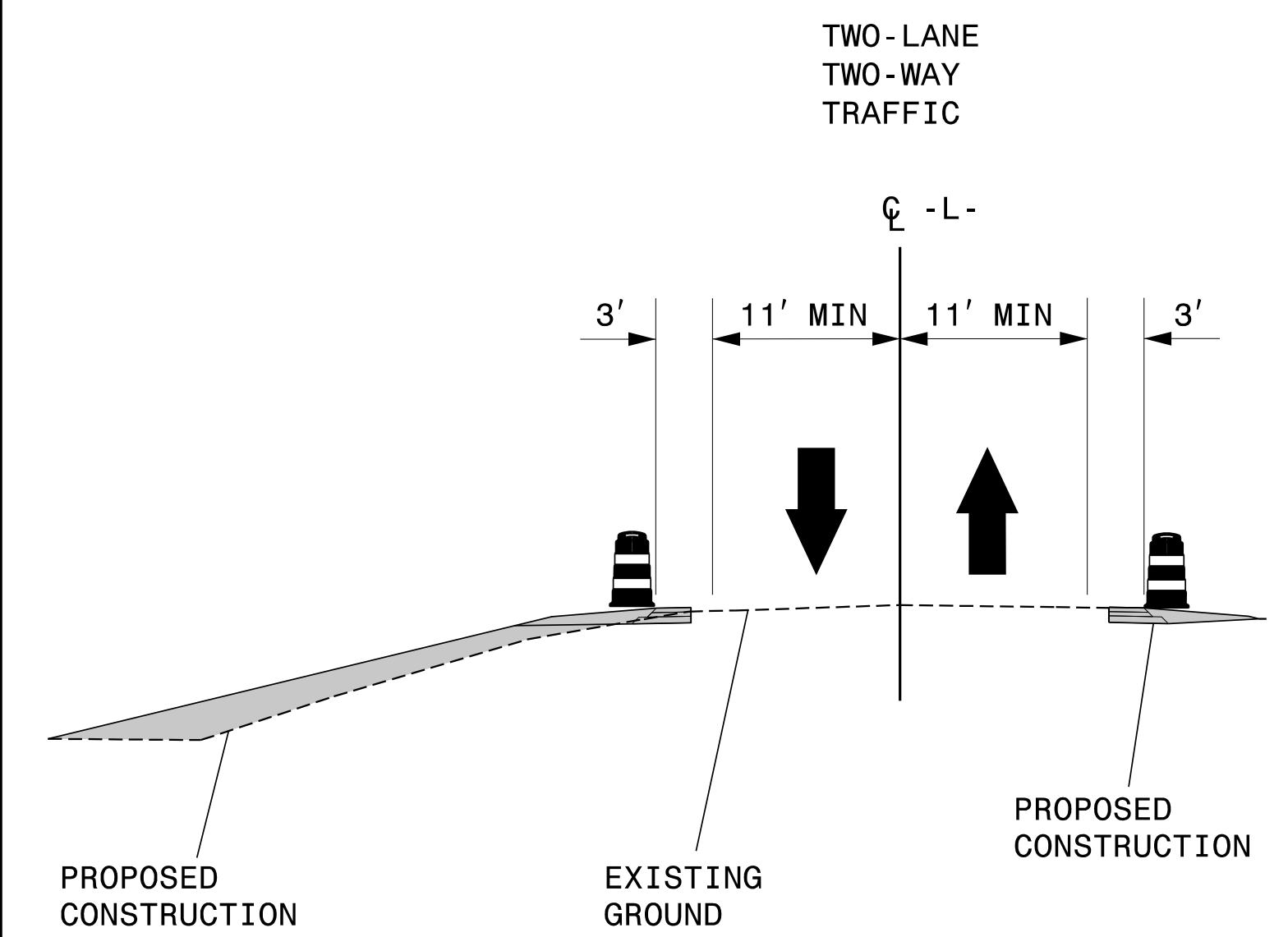

### SECTION B-B

17+00

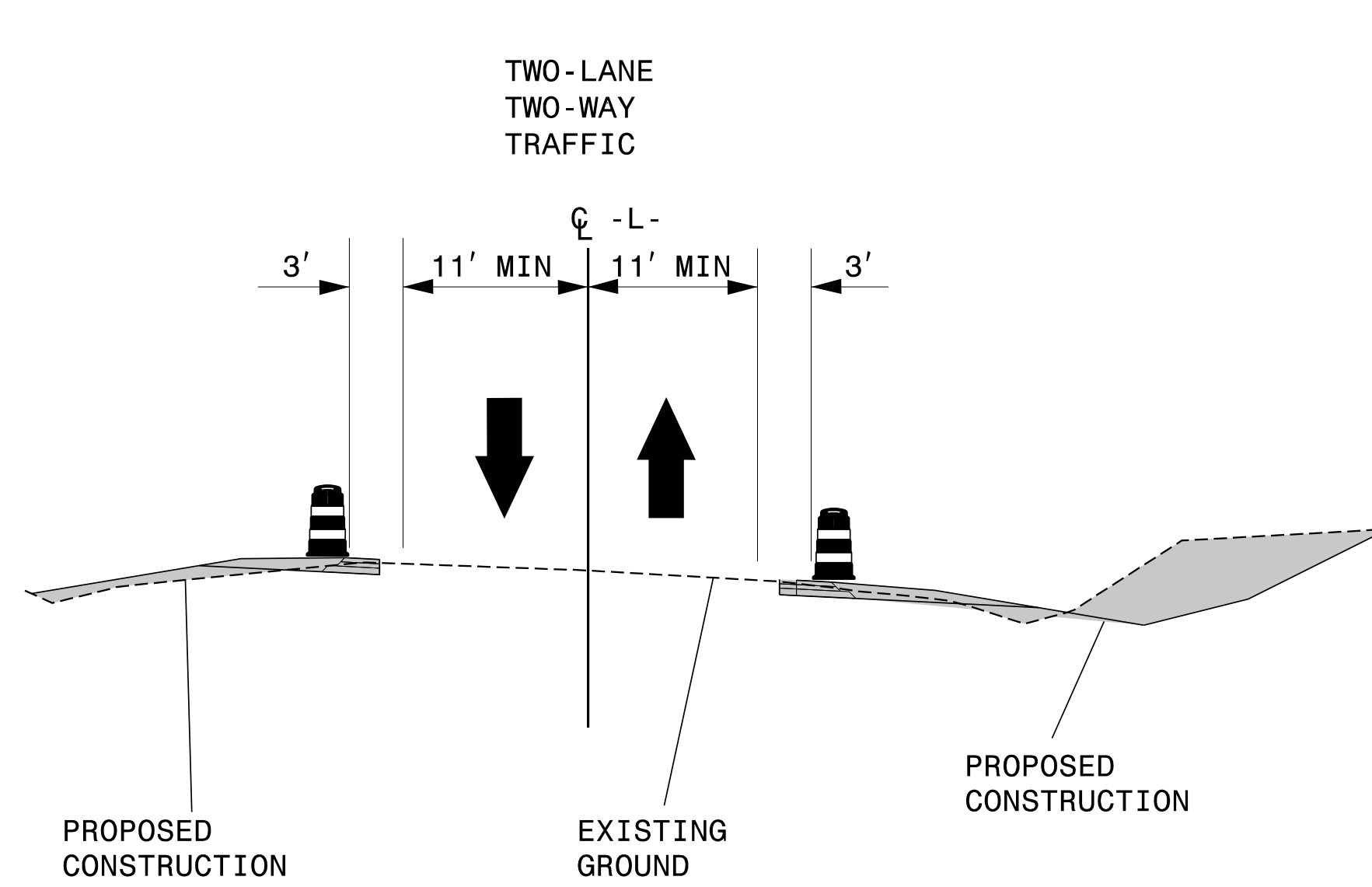

### SECTION C-C

22+00

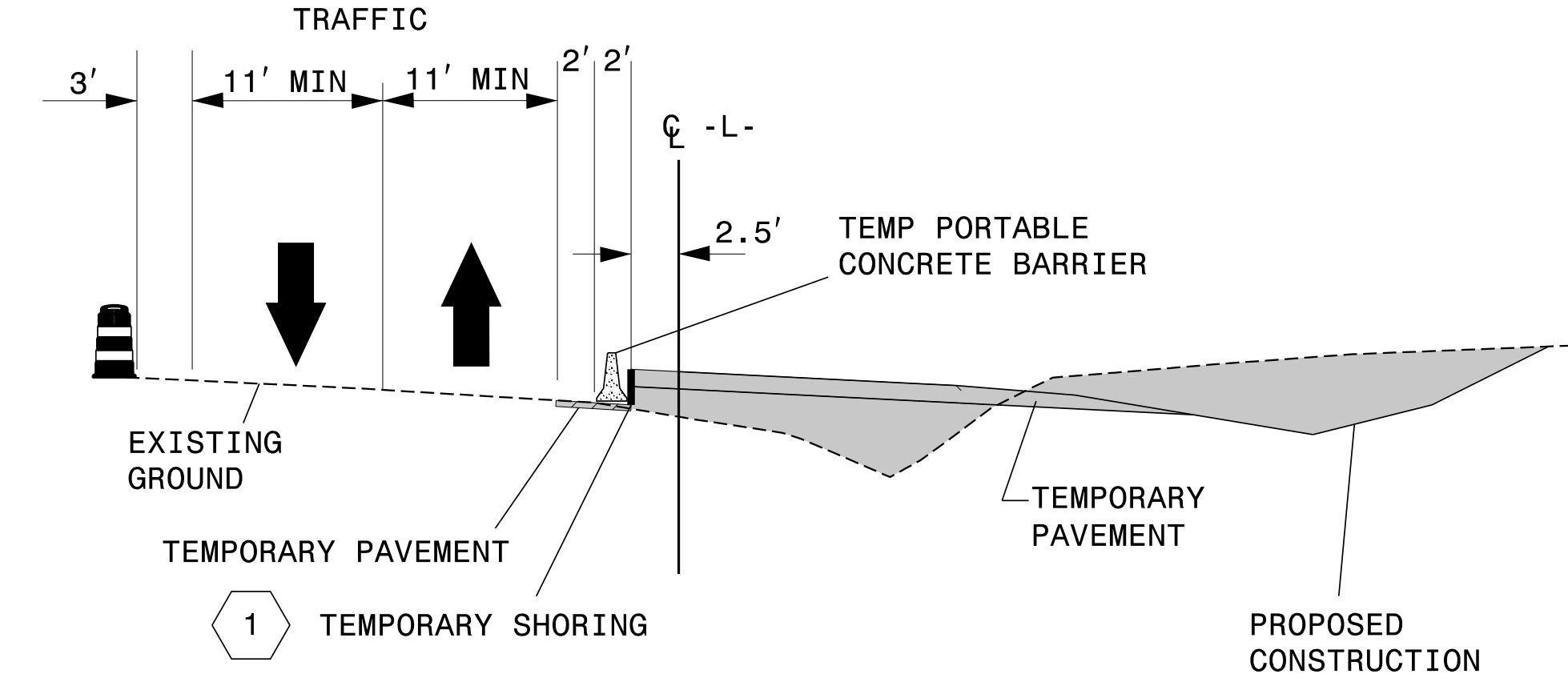

APPROVED: *Lloyd D. Brown*  
DATE: 4/9/2021

SEAL

DOCUMENT NOT CONSIDERED FINAL  
UNLESS ALL SIGNATURES COMPLETED

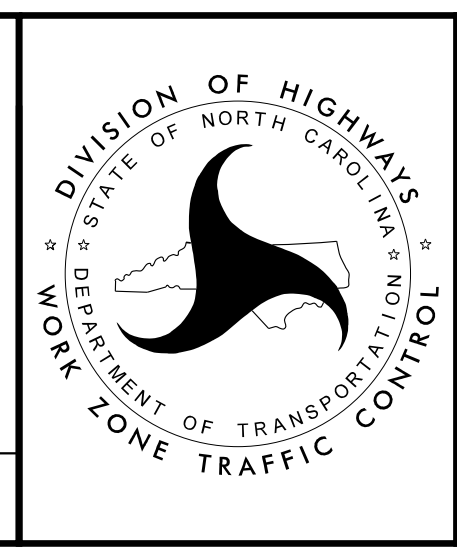

TEMPORARY TRAFFIC CONTROL PHASE I  
DETAIL

4/9/2021 12:50:34 PM  
...B4407\_TMP-5.dgn  
User:cmfittzpatrick