

8/17/19

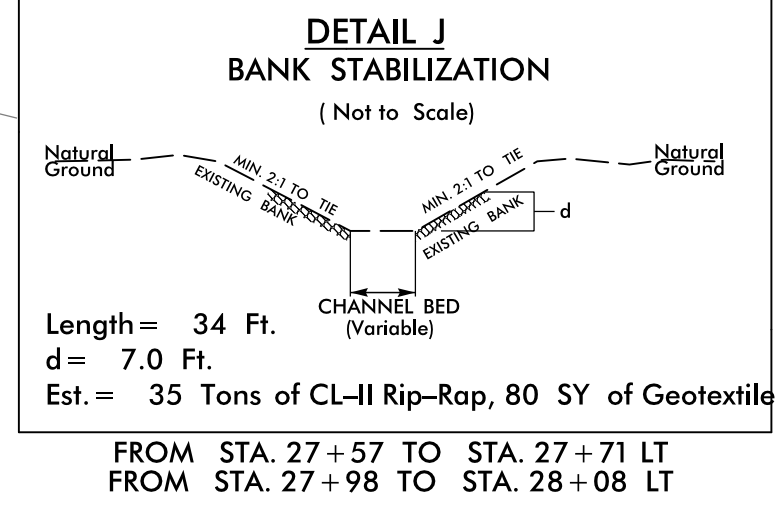

PROJECT REFERENCE NO. B-5818		SHEET NO. 7	
RW SHEET NO.		HYDRAULICS ENGINEER	
ROADWAY DESIGN ENGINEER		HYDRAULICS ENGINEER	
DOCUMENT NOT CONSIDERED FINAL UNLESS ALL SIGNATURES COMPLETED			

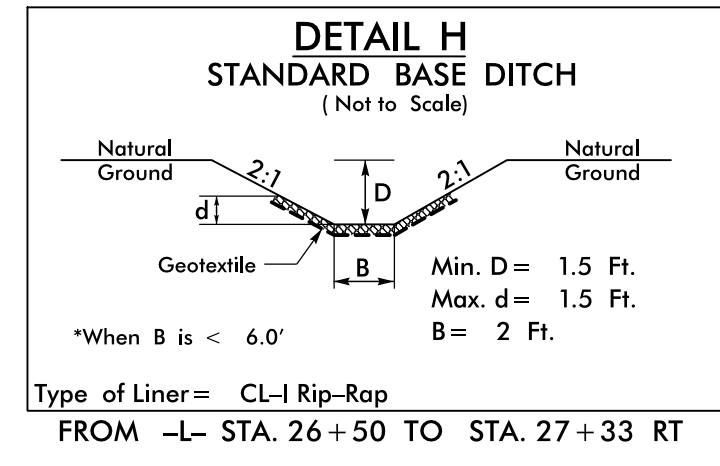
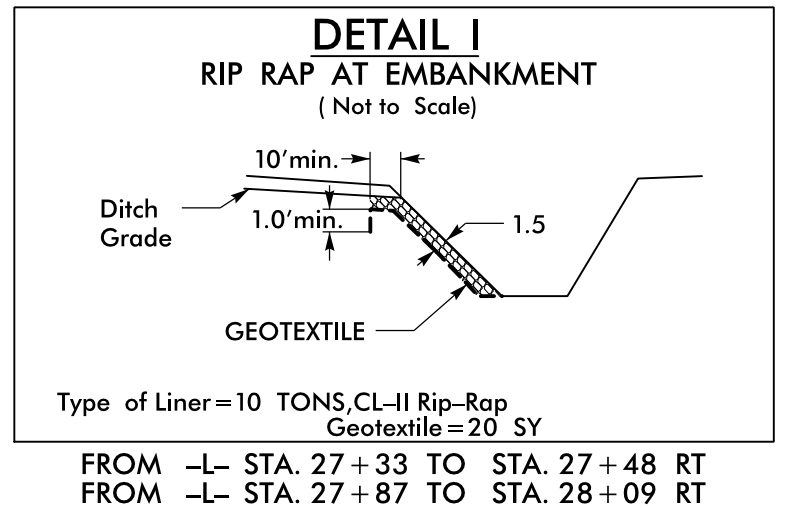
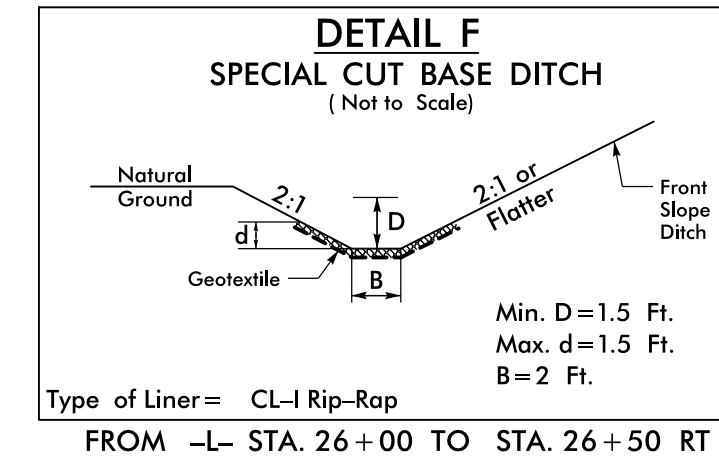
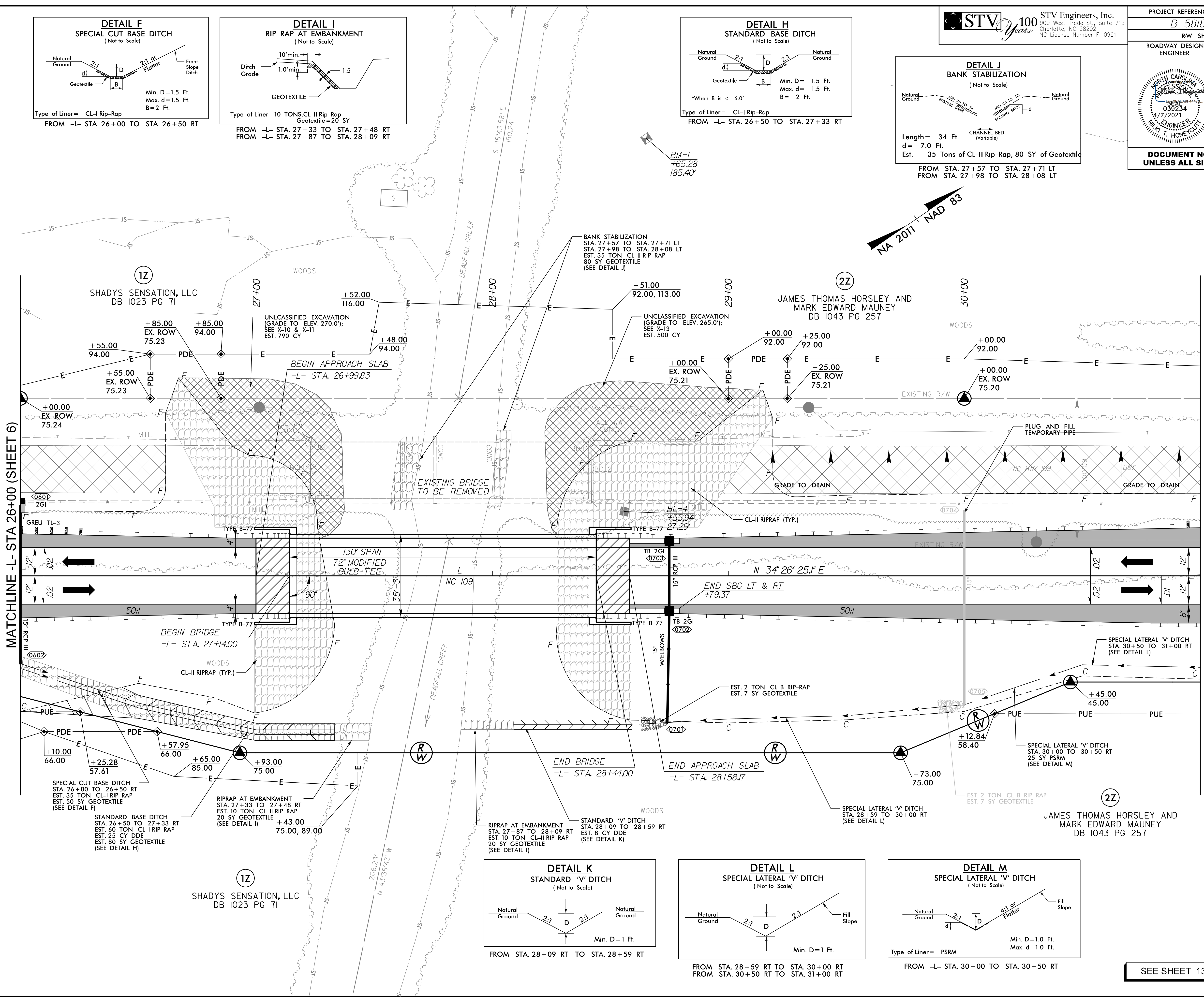

MATCHLINE -L- STA 26+00 (SHEET 6)

MATCHLINE -L- STA 31+00 (SHEET 8)

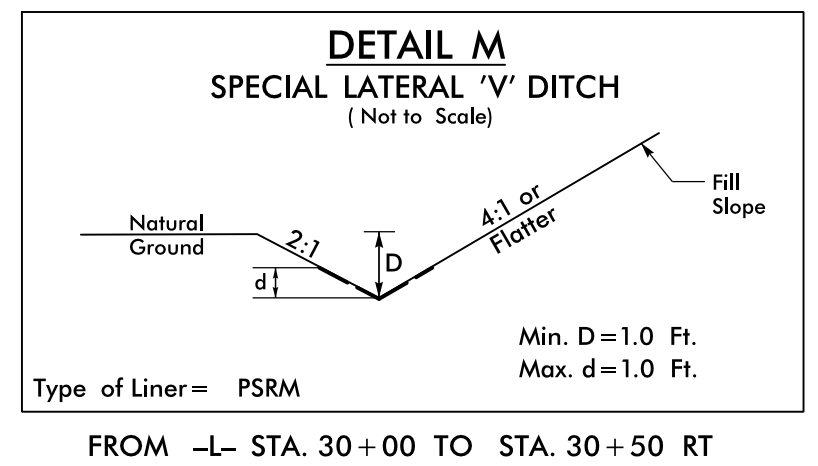
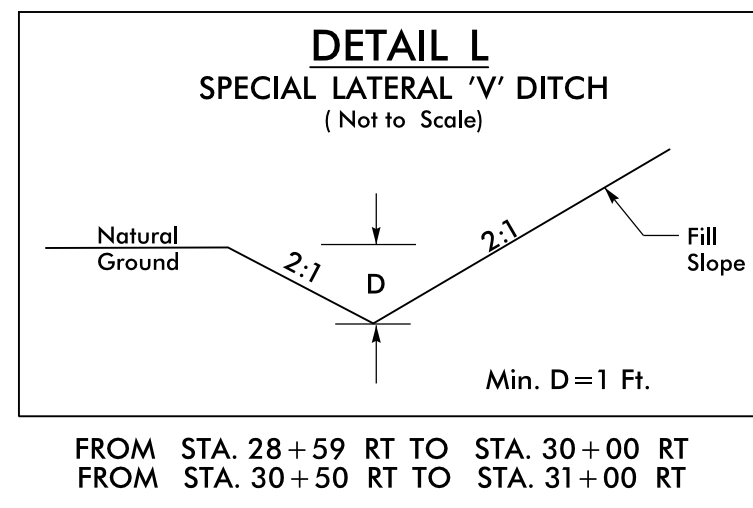
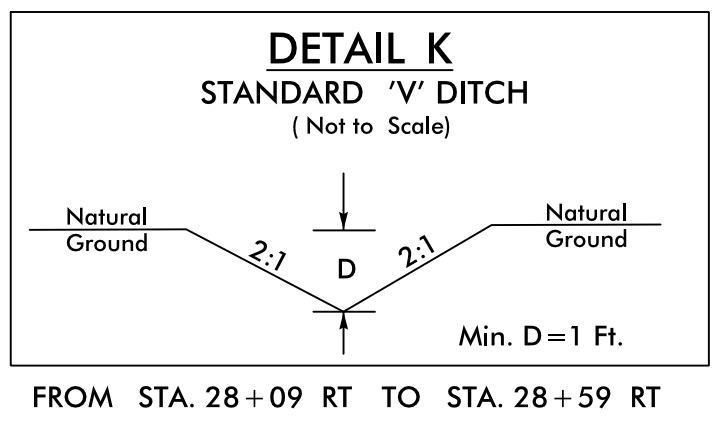

SEE SHEET 13 FOR -L- PROFILE

4/7/2021 4:11:00 PM C:\projects\shadys\B5818.rdy_psh07.dgn