

**PLAN OF FLOOR SLAB**

#4C1 BARS SHALL BE FIELD BENT AS NECESSARY

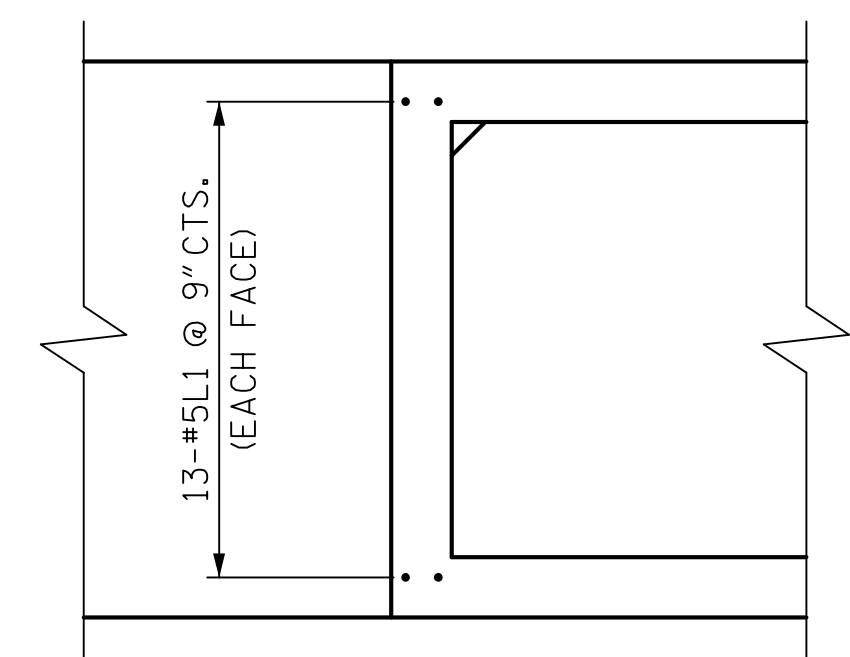

**DETAIL "E"**

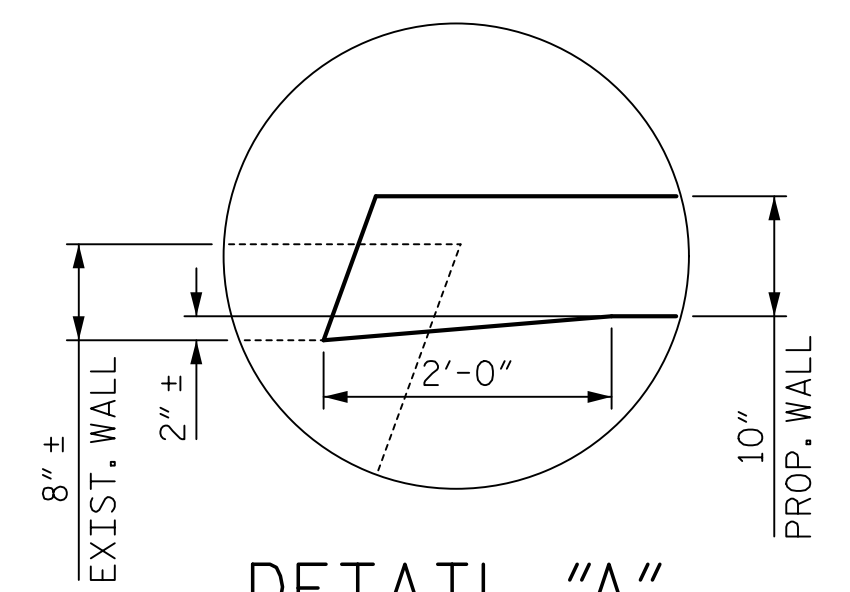

**DETAIL "A"**

(RIGHT EXT. SHOWN, LEFT EXT. SIMILAR)

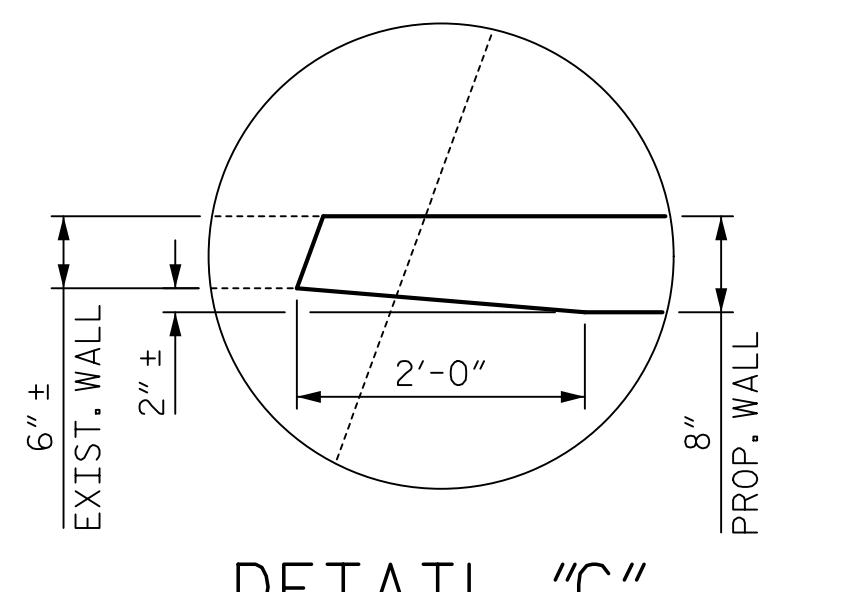

**DETAIL "C"**

(RIGHT EXT. SHOWN, LEFT EXT. SIMILAR)

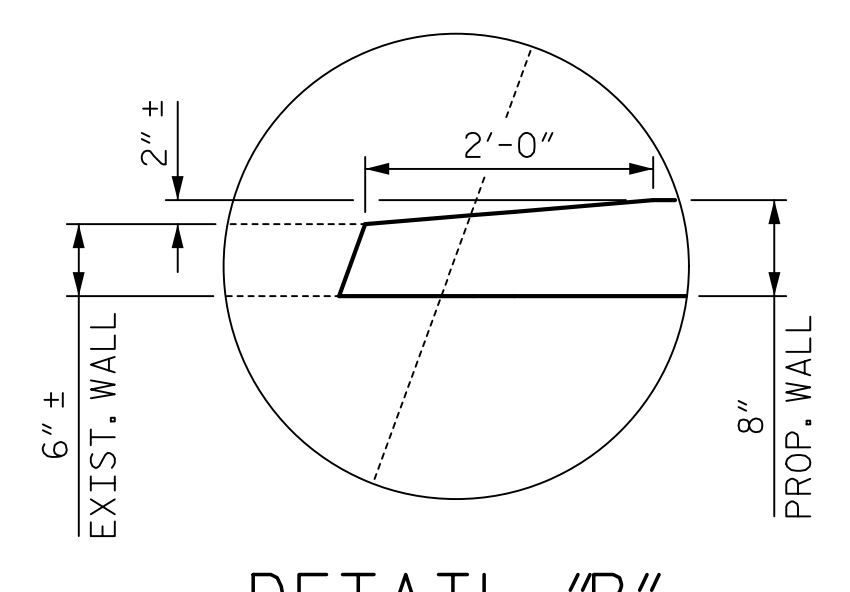

**DETAIL "B"**

(RIGHT EXT. SHOWN, LEFT EXT. SIMILAR)

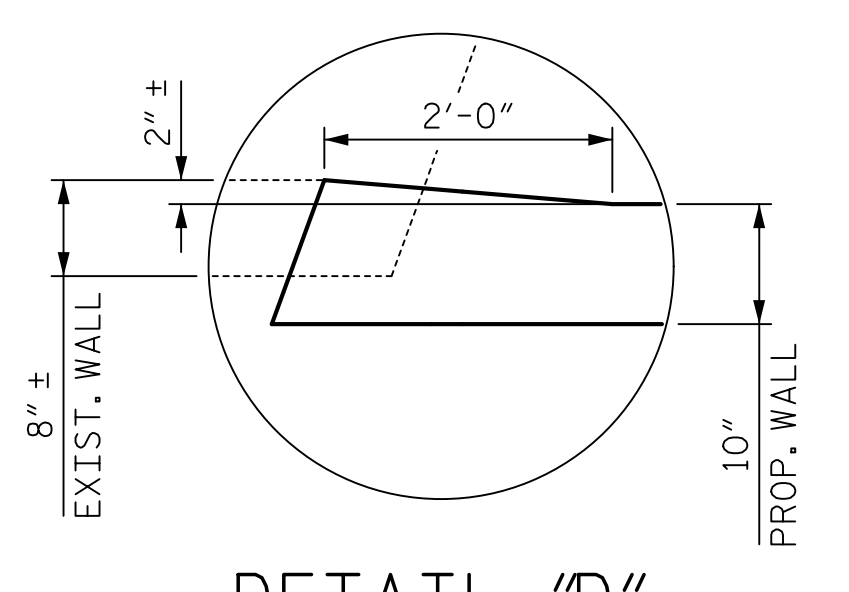

**DETAIL "D"**

(RIGHT EXT. SHOWN, LEFT EXT. SIMILAR)



111 E. Hargett Street  
Suite 300  
Raleigh, NC 27601  
919-714-8670  
meadhunt.com  
NC License No. F-1235

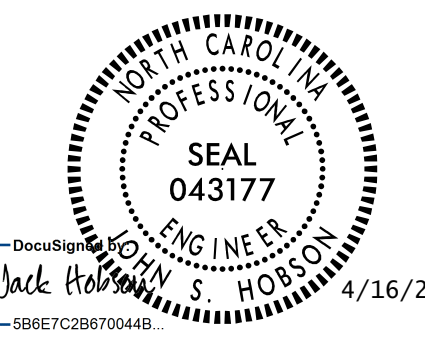

PROJECT NO. R-4707  
GUILFORD COUNTY  
STATION: 56+34.85 -L-  
SHEET 8 OF 16

STATE OF NORTH CAROLINA  
DEPARTMENT OF TRANSPORTATION  
RALEIGH  
**TRIPLE 7 FT. x 8 FT.  
REINFORCED CONCRETE  
BOX CULVERT**  
(RIGHT EXTENSION)

DRAWN BY : J.S. HOBSON DATE : 04/01/19  
CHECKED BY : J.A. LEE DATE : 04/18/19  
DESIGN ENGINEER OF RECORD : J.S. HOBSON DATE : 04/26/19

DOCUMENT NOT CONSIDERED  
FINAL UNLESS ALL  
SIGNATURES COMPLETED

REVISIONS						SHEET NO.
NO.	BY:	DATE:	NO.	BY:	DATE:	C1-16
1			3			TOTAL SHEETS
2			4			24