

DEAD LOAD DEFLECTION TABLE FOR GIRDERS

| 0.6" Ø LOW RELAXATION | SPAN "A" | | | | | | | | | | | SPAN "B" | | | | | | | | | | | |
|---------------------------------------|----------------|-------|-------|-------|-------|-------|--------|-------|-------|-------|-------|----------------|-------|-------|-------|-------|-------|--------|-------|-------|-------|-------|-------|
| | GIRDERS 1 & 11 | | | | | | | | | | | GIRDERS 1 & 11 | | | | | | | | | | | |
| TENTH POINTS | 0 | 0.1 | 0.2 | 0.3 | 0.4 | 0.5 | 0.6 | 0.7 | 0.8 | 0.9 | 1.0 | 0 | 0.1 | 0.2 | 0.3 | 0.4 | 0.5 | 0.6 | 0.7 | 0.8 | 0.9 | 1.0 | |
| CAMBER (GIRDER ALONE IN PLACE) | ↑ | 0.000 | 0.041 | 0.077 | 0.105 | 0.123 | 0.130 | 0.123 | 0.105 | 0.077 | 0.041 | 0.000 | 0.000 | 0.041 | 0.077 | 0.105 | 0.123 | 0.130 | 0.123 | 0.105 | 0.077 | 0.041 | 0.000 |
| * DEFLECTION DUE TO SUPERIMPOSED D.L. | ↓ | 0.000 | 0.022 | 0.043 | 0.059 | 0.069 | 0.073 | 0.069 | 0.058 | 0.042 | 0.021 | 0.000 | 0.000 | 0.021 | 0.042 | 0.058 | 0.069 | 0.073 | 0.070 | 0.059 | 0.043 | 0.022 | 0.000 |
| FINAL CAMBER | ↑ | 0" | 1/4" | 7/16" | 9/16" | 5/8" | 11/16" | 5/8" | 9/16" | 7/16" | 1/4" | 0" | 0" | 1/4" | 7/16" | 9/16" | 5/8" | 11/16" | 5/8" | 9/16" | 7/16" | 1/4" | 0" |

DEAD LOAD DEFLECTION TABLE FOR GIRDERS

| 0.6" Ø LOW RELAXATION | SPAN "A" | | | | | | | | | | | SPAN "B" | | | | | | | | | | | |
|---------------------------------------|----------------|-------|-------|-------|-------|-------|-------|-------|-------|-------|-------|----------------|-------|-------|-------|-------|-------|-------|-------|-------|-------|-------|-------|
| | GIRDERS 2 & 10 | | | | | | | | | | | GIRDERS 2 & 10 | | | | | | | | | | | |
| TENTH POINTS | 0 | 0.1 | 0.2 | 0.3 | 0.4 | 0.5 | 0.6 | 0.7 | 0.8 | 0.9 | 1.0 | 0 | 0.1 | 0.2 | 0.3 | 0.4 | 0.5 | 0.6 | 0.7 | 0.8 | 0.9 | 1.0 | |
| CAMBER (GIRDER ALONE IN PLACE) | ↑ | 0.000 | 0.041 | 0.077 | 0.105 | 0.123 | 0.130 | 0.123 | 0.105 | 0.077 | 0.041 | 0.000 | 0.000 | 0.041 | 0.077 | 0.105 | 0.123 | 0.130 | 0.123 | 0.105 | 0.077 | 0.041 | 0.000 |
| * DEFLECTION DUE TO SUPERIMPOSED D.L. | ↓ | 0.000 | 0.026 | 0.051 | 0.070 | 0.082 | 0.086 | 0.082 | 0.069 | 0.050 | 0.025 | 0.000 | 0.000 | 0.025 | 0.050 | 0.069 | 0.082 | 0.086 | 0.082 | 0.070 | 0.051 | 0.026 | 0.000 |
| FINAL CAMBER | ↑ | 0" | 3/16" | 5/16" | 7/16" | 1/2" | 1/2" | 1/2" | 7/16" | 5/16" | 3/16" | 0" | 0" | 3/16" | 5/16" | 7/16" | 1/2" | 1/2" | 1/2" | 7/16" | 5/16" | 3/16" | 0" |

DEAD LOAD DEFLECTION TABLE FOR GIRDERS

| 0.6" Ø LOW RELAXATION | SPAN "A" | | | | | | | | | | | SPAN "B" | | | | | | | | | | | |
|---------------------------------------|----------------------|-------|-------|-------|-------|-------|-------|-------|-------|-------|-------|----------------------|-------|-------|-------|-------|-------|-------|-------|-------|-------|-------|-------|
| | GIRDERS 3, 4, 7, & 9 | | | | | | | | | | | GIRDERS 3, 4, 7, & 9 | | | | | | | | | | | |
| TENTH POINTS | 0 | 0.1 | 0.2 | 0.3 | 0.4 | 0.5 | 0.6 | 0.7 | 0.8 | 0.9 | 1.0 | 0 | 0.1 | 0.2 | 0.3 | 0.4 | 0.5 | 0.6 | 0.7 | 0.8 | 0.9 | 1.0 | |
| CAMBER (GIRDER ALONE IN PLACE) | ↑ | 0.000 | 0.041 | 0.077 | 0.105 | 0.123 | 0.130 | 0.123 | 0.105 | 0.077 | 0.041 | 0.000 | 0.000 | 0.041 | 0.077 | 0.105 | 0.123 | 0.130 | 0.123 | 0.105 | 0.077 | 0.041 | 0.000 |
| * DEFLECTION DUE TO SUPERIMPOSED D.L. | ↓ | 0.000 | 0.025 | 0.050 | 0.069 | 0.082 | 0.086 | 0.081 | 0.069 | 0.049 | 0.025 | 0.000 | 0.000 | 0.025 | 0.049 | 0.069 | 0.081 | 0.086 | 0.082 | 0.069 | 0.050 | 0.025 | 0.000 |
| FINAL CAMBER | ↑ | 0" | 3/16" | 5/16" | 7/16" | 1/2" | 1/2" | 1/2" | 7/16" | 5/16" | 3/16" | 0" | 0" | 3/16" | 5/16" | 7/16" | 1/2" | 1/2" | 1/2" | 7/16" | 5/16" | 3/16" | 0" |

DEAD LOAD DEFLECTION TABLE FOR GIRDERS

| 0.6" Ø LOW RELAXATION | SPAN "A" | | | | | | | | | | | SPAN "B" | | | | | | | | | | | |
|---------------------------------------|---------------|-------|-------|-------|-------|-------|-------|-------|-------|-------|-------|---------------|-------|-------|-------|-------|-------|-------|-------|-------|-------|-------|-------|
| | GIRDERS 5 & 6 | | | | | | | | | | | GIRDERS 5 & 6 | | | | | | | | | | | |
| TENTH POINTS | 0 | 0.1 | 0.2 | 0.3 | 0.4 | 0.5 | 0.6 | 0.7 | 0.8 | 0.9 | 1.0 | 0 | 0.1 | 0.2 | 0.3 | 0.4 | 0.5 | 0.6 | 0.7 | 0.8 | 0.9 | 1.0 | |
| CAMBER (GIRDER ALONE IN PLACE) | ↑ | 0.000 | 0.041 | 0.077 | 0.105 | 0.123 | 0.130 | 0.123 | 0.105 | 0.077 | 0.041 | 0.000 | 0.000 | 0.041 | 0.077 | 0.105 | 0.123 | 0.130 | 0.123 | 0.105 | 0.077 | 0.041 | 0.000 |
| * DEFLECTION DUE TO SUPERIMPOSED D.L. | ↓ | 0.000 | 0.023 | 0.046 | 0.063 | 0.074 | 0.078 | 0.074 | 0.062 | 0.044 | 0.022 | 0.000 | 0.000 | 0.022 | 0.045 | 0.062 | 0.074 | 0.078 | 0.075 | 0.063 | 0.046 | 0.023 | 0.000 |
| FINAL CAMBER | ↑ | 0" | 3/16" | 3/8" | 1/2" | 9/16" | 5/8" | 5/8" | 1/2" | 3/8" | 1/4" | 0" | 0" | 1/4" | 3/8" | 1/2" | 9/16" | 5/8" | 9/16" | 1/2" | 3/8" | 3/16" | 0" |

DEAD LOAD DEFLECTION TABLE FOR GIRDERS

| 0.6" Ø LOW RELAXATION | SPAN "A" | | | | | | | | | | | SPAN "B" | | | | | | | | | | | |
|---------------------------------------|----------|-------|-------|-------|-------|-------|-------|-------|-------|-------|-------|----------|-------|-------|-------|-------|-------|-------|-------|-------|-------|-------|-------|
| | GIRDER 8 | | | | | | | | | | | GIRDER 8 | | | | | | | | | | | |
| TENTH POINTS | 0 | 0.1 | 0.2 | 0.3 | 0.4 | 0.5 | 0.6 | 0.7 | 0.8 | 0.9 | 1.0 | 0 | 0.1 | 0.2 | 0.3 | 0.4 | 0.5 | 0.6 | 0.7 | 0.8 | 0.9 | 1.0 | |
| CAMBER (GIRDER ALONE IN PLACE) | ↑ | 0.000 | 0.041 | 0.077 | 0.105 | 0.123 | 0.130 | 0.123 | 0.105 | 0.077 | 0.041 | 0.000 | 0.000 | 0.041 | 0.077 | 0.105 | 0.123 | 0.130 | 0.123 | 0.105 | 0.077 | 0.041 | 0.000 |
| * DEFLECTION DUE TO SUPERIMPOSED D.L. | ↓ | 0.000 | 0.025 | 0.050 | 0.069 | 0.081 | 0.085 | 0.081 | 0.068 | 0.049 | 0.025 | 0.000 | 0.000 | 0.025 | 0.049 | 0.068 | 0.081 | 0.085 | 0.081 | 0.069 | 0.050 | 0.025 | 0.000 |
| FINAL CAMBER | ↑ | 0" | 3/16" | 5/16" | 7/16" | 1/2" | 9/16" | 1/2" | 7/16" | 5/16" | 3/16" | 0" | 0" | 3/16" | 5/16" | 7/16" | 1/2" | 9/16" | 1/2" | 7/16" | 5/16" | 3/16" | 0" |

* INCLUDES FUTURE WEARING SURFACE
ALL VALUES ARE SHOWN IN FEET (DECIMAL FORM), EXCEPT " FINAL CAMBER ", WHICH IS GIVEN IN INCHES (FRACTION FORM).

NOTES

ALL PRESTRESSING STRANDS SHALL BE 7-WIRE LOW-RELAXATION GRADE 270 STRANDS AND SHALL CONFORM TO AASHTO M203 EXCEPT FOR SAMPLING REQUIREMENTS WHICH SHALL BE IN ACCORDANCE WITH THE STANDARD SPECIFICATIONS.

ALL REINFORCING STEEL SHALL BE GRADE 60.

APPLY EPOXY PROTECTIVE COATING TO END OF GIRDER SURFACES INDICATED IN ELEVATION VIEW.

EMBEDDED PLATE "B-1" SHALL BE GALVANIZED IN ACCORDANCE WITH THE STANDARD SPECIFICATIONS.

ANCHOR STUDS SHALL CONFORM TO AASHTO M169 GRADES 1010 THROUGH 1020 OR APPROVED EQUAL, AND SHALL MEET THE TYPE "B" REQUIREMENTS OF SUBSECTION 7.3 OF THE ANSI/AASHTO/AWS D1.5 BRIDGE WELDING CODE.

AT ENDS OF GIRDERS TO BE EMBEDDED IN CONCRETE DIAPHRAGMS OR END WALLS, PRESTRESSING STRANDS MAY EXTEND A MAXIMUM OF 2" BEYOND THE GIRDER ENDS. OTHERWISE, PRESTRESSING STRANDS SHALL BE CUT FLUSH WITH THE GIRDER ENDS.

THE TRANSFER OF LOAD FROM THE ANCHORAGES TO THE GIRDER SHALL BE DONE WHEN CONCRETE HAS REACHED A COMPRESSIVE STRENGTH OF NOT LESS THAN 4000 PSI.

DEPENDING ON THE TYPE OF SYSTEM USED TO SUPPORT THE DECK SLAB FORMS, PRESET ANCHORS MAY BE NECESSARY IN THE PRESTRESSED CONCRETE GIRDER.

THE TOP SURFACE OF THE GIRDER, EXCLUDING THE OUTSIDE 4", SHALL BE RAKED TO A DEPTH OF 1/4".

THE CONTRACTOR HAS THE OPTION TO PROVIDE, AT NO ADDITIONAL COST TO THE DEPARTMENT, 2 ADDITIONAL STRANDS AT THE TOP OF THE GIRDER TO FACILITATE TYING OF THE REINFORCING STEEL. THESE STRANDS SHALL BE PULLED TO A LOAD OF 4500 LBS.

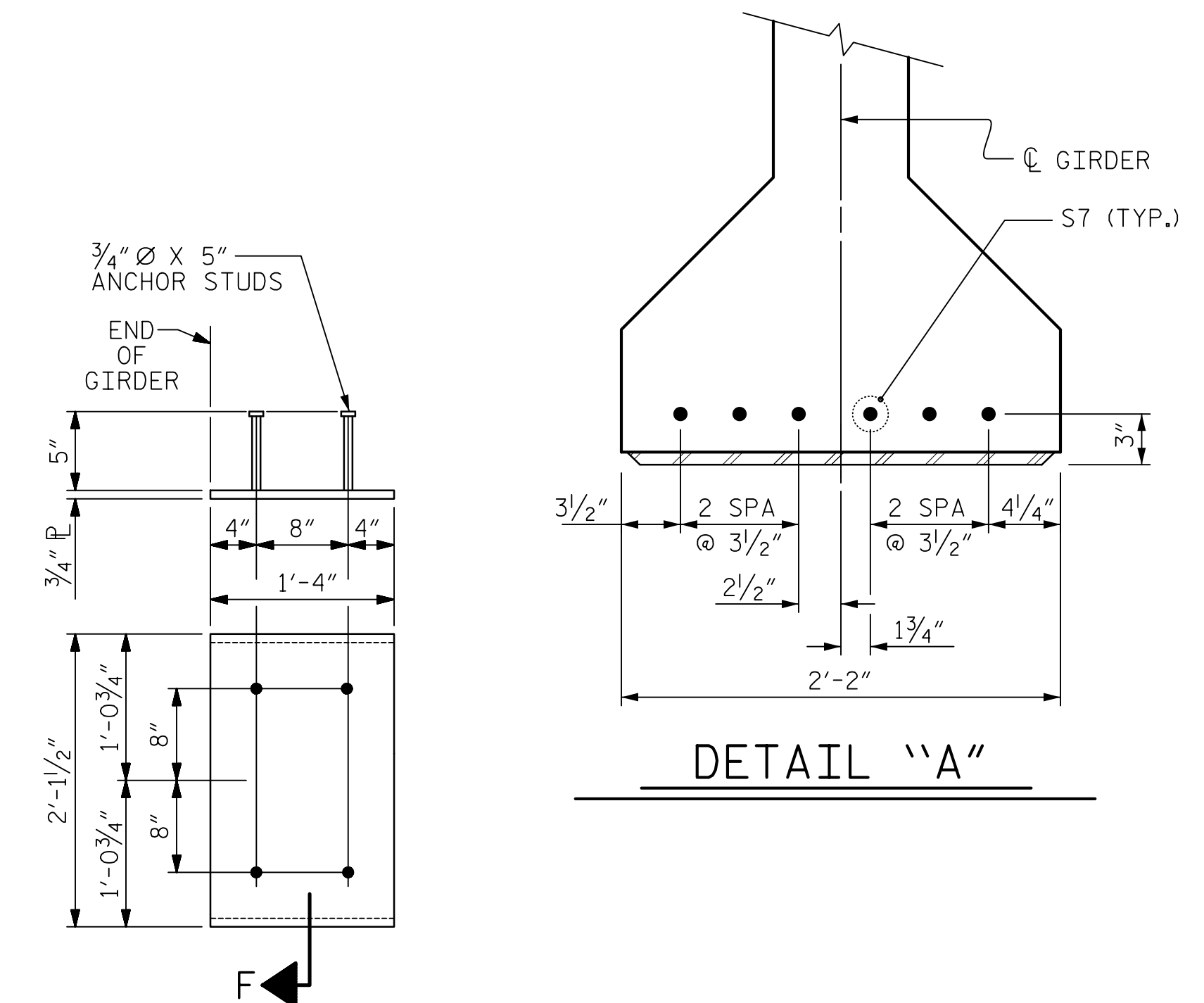

EMBEDDED PLATE "B-1" DETAILS FOR AASHTO TYPE IV GIRDER

(2 REQ'D PER GIRDER)

PROJECT NO. R-4707
GUILFORD COUNTY
STATION: 41+39.51 -Y-

SHEET 2 OF 3

Mead & Hunt

111 E. Hargett Street
Suite 300
Raleigh, NC 27601
919-714-8670
meadhunt.com
NC License No. F-1235



DocuSign
Jack Hobson
SBR67C286700448 4/16/2020

DOCUMENT NOT CONSIDERED FINAL UNLESS ALL SIGNATURES COMPLETED

STATE OF NORTH CAROLINA
DEPARTMENT OF TRANSPORTATION
RALEIGH
STANDARD
PRESTRESSED CONCRETE GIRDER
CONTINUOUS FOR LIVE LOAD
DETAILS

| REVISIONS | | | | | | SHEET NO. |
|-----------|-----|-------|-----|-----|-------|--------------|
| NO. | BY: | DATE: | NO. | BY: | DATE: | S-12 |
| 1 | | | 3 | | | TOTAL SHEETS |
| 2 | | | 4 | | | 39 |

| | |
|----------------------------|--------------------|
| ASSEMBLED BY : J.S. HOBSON | DATE : 10/05/18 |
| CHECKED BY : A.J. FORFA | DATE : 10/17/18 |
| DRAWN BY : ELR 11/91 | REV. 1/15 MAA/TMG |
| CHECKED BY : GRP 11/91 | REV. 2/15 MAA/TMG |
| | REV. 12/17 MAA/THC |

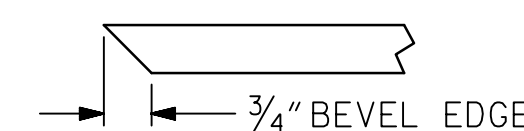

SECTION "F"

(SEE NOTES)