

PROJECT REFERENCE NO. R-4707	SHEET NO. 2D-1
ROADWAY DESIGN ENGINEER SEAL 034381 RICHARD S. DELOACH	HYDRAULICS ENGINEER SEAL 21656 R. W. MEAD
DOCUMENT NOT CONSIDERED FINAL UNLESS ALL SIGNATURES COMPLETED	
Mead & Hunt 111 E. Hargett Street, Suite 300 Raleigh, North Carolina 27601 919-714-8670 mead@mead.com NC License No. F-1235	

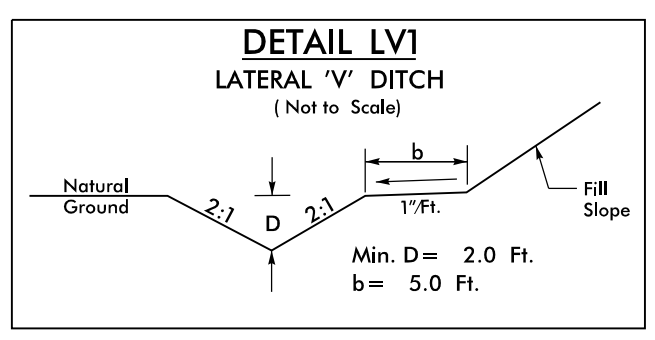

FROM STA. L RT 32+30 TO STA. L RT 36+30
FROM STA. L RT 36+30 TO STA. L RT 37+00
FROM STA. L LT 37+50 TO STA. L LT 38+50

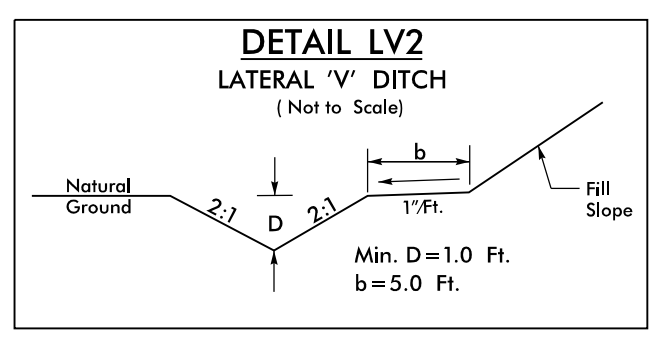

FROM STA. L RT 37+00 TO STA. L RT 40+00

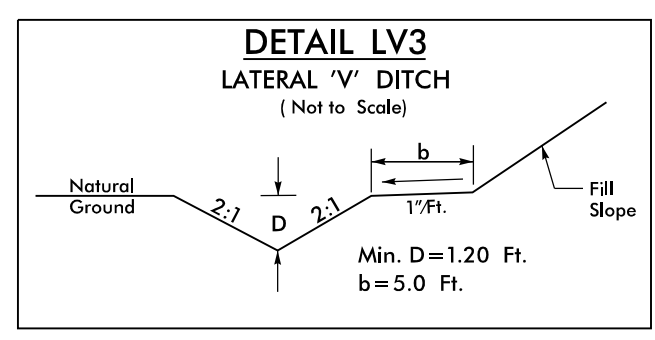

FROM STA. L LT 39+50 TO STA. L LT 41+00

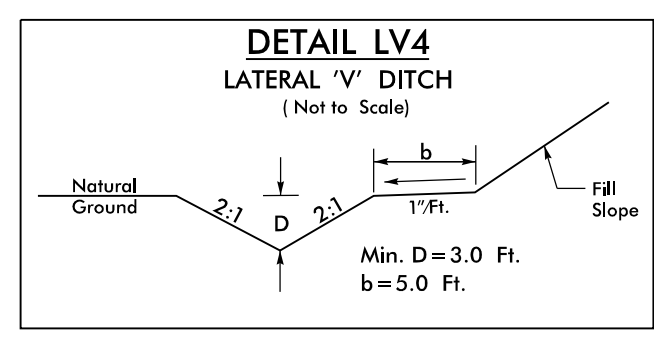

FROM STA. L LT 62+50 TO STA. L LT 66+00

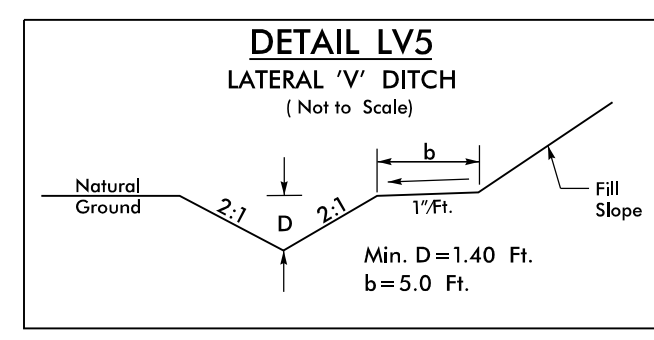

FROM STA. Y1 RT 13+25 TO STA. Y1 RT 13+50
FROM STA. Y1 RT 16+00 TO STA. Y1 RT 16+91

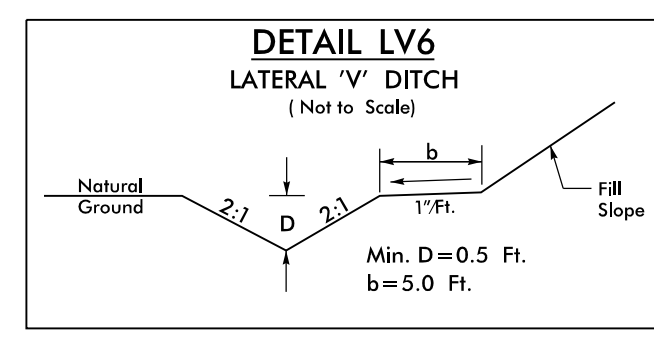

FROM STA. Y1 RT 20+00 TO STA. Y1 RT 25+00

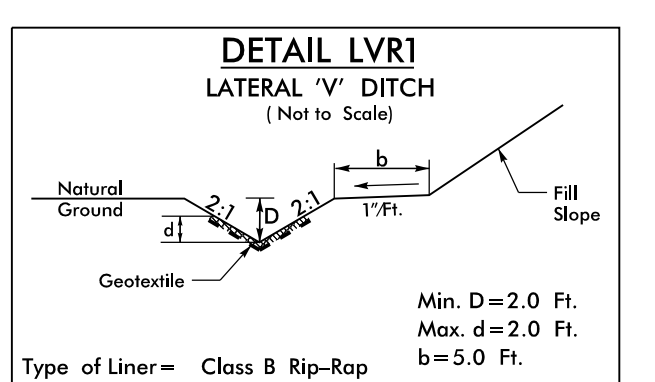

FROM STA. RPD RT 20+50 TO STA. RPD RT 23+90

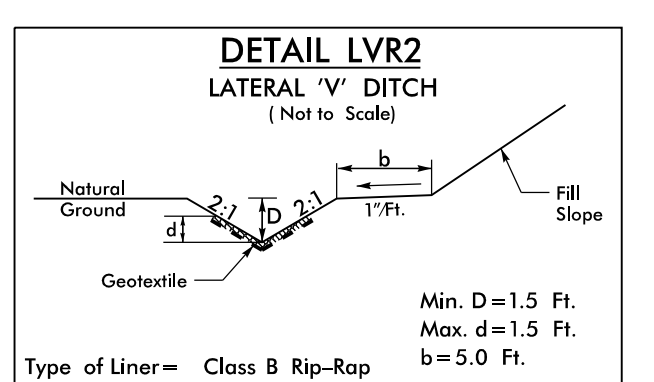

FROM STA. L RT 77+50 TO STA. L RT 80+50

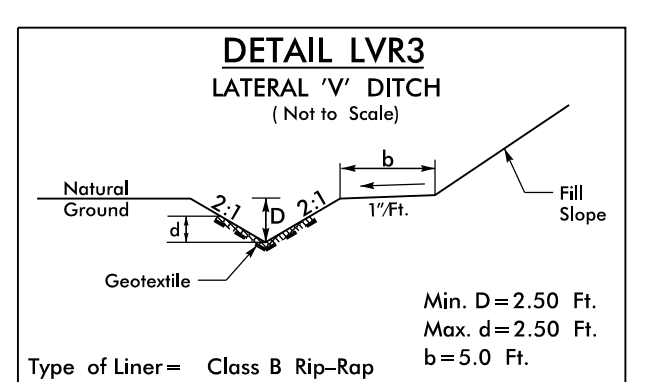

FROM STA. L LT 73+50 TO STA. L LT 77+00

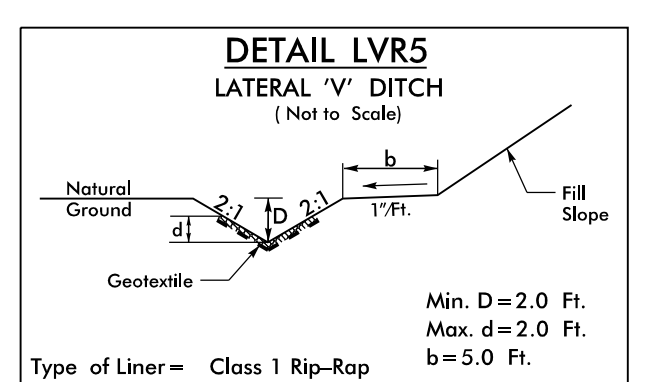

FROM STA. SPB LT 42+00 TO STA. RPB LT 40+50

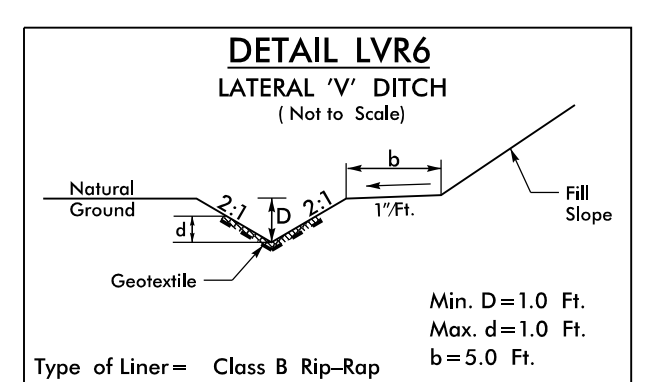

FROM STA. RPA LT 26+50 TO STA. Y LT 40+00

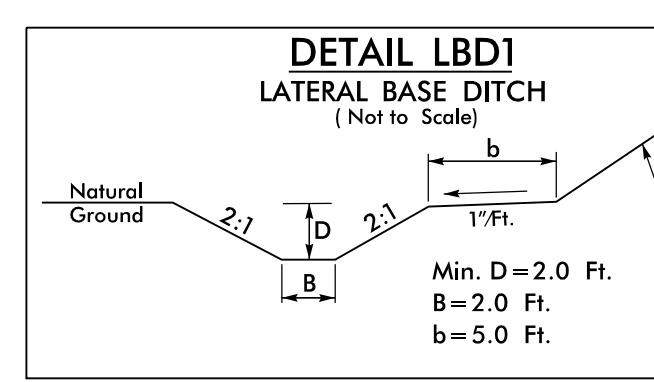

FROM STA. Y LT 29+68 TO STA. Y LT 30+50

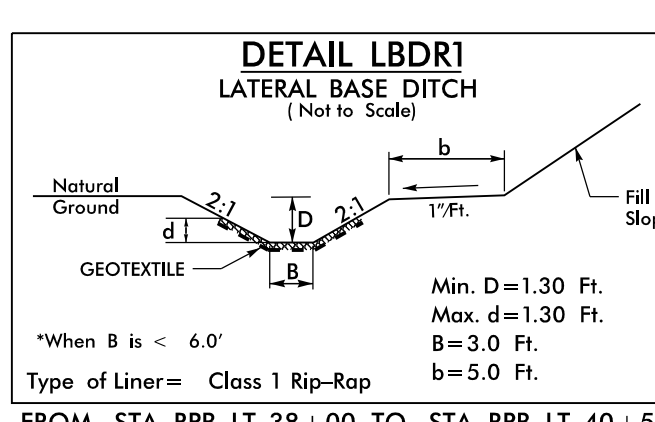

FROM STA. RPB LT 38+00 TO STA. RPB LT 40+50

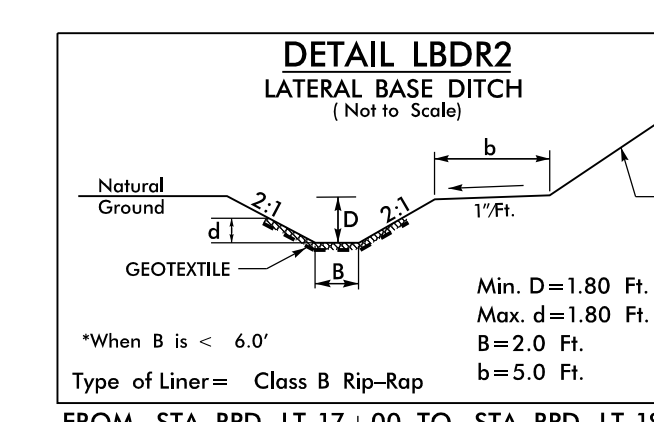

FROM STA. RPD LT 17+00 TO STA. RPD LT 18+50

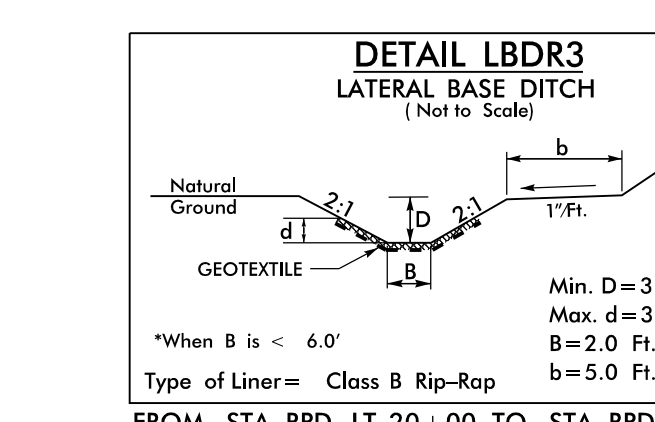

FROM STA. RPD LT 20+00 TO STA. RPD LT 21+25

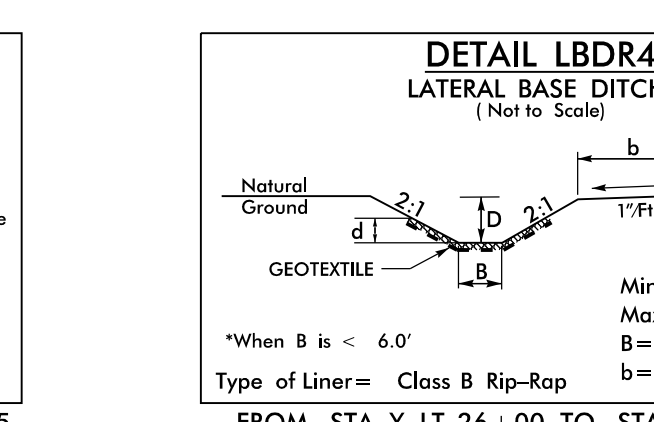

FROM STA. Y LT 26+00 TO STA. Y LT 29+68

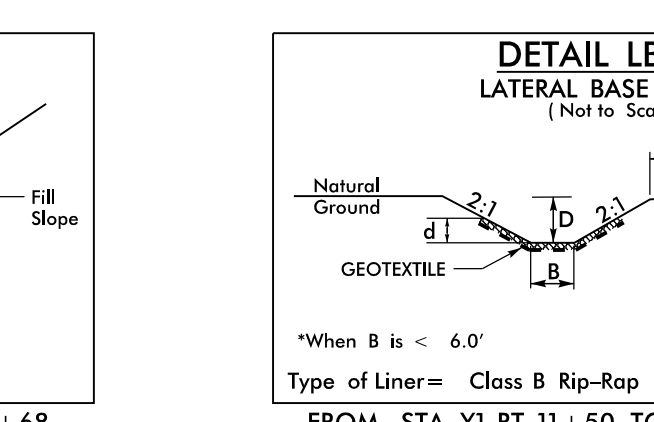

FROM STA. Y1 RT 11+50 TO STA. Y1 RT 13+25

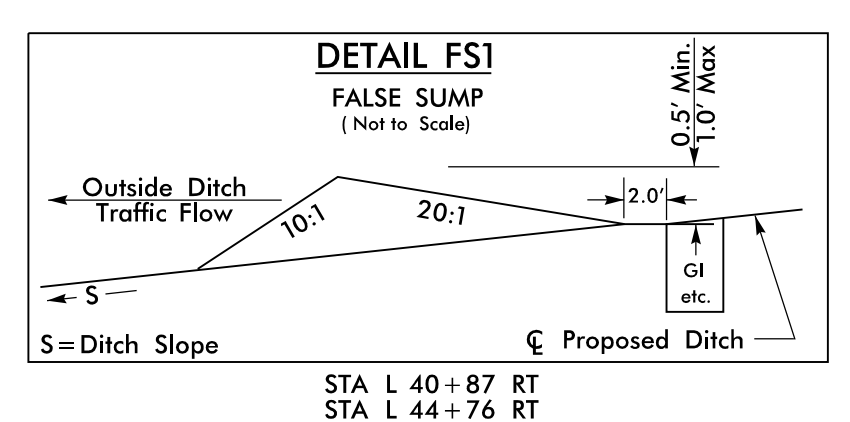

STA L 40+87 RT
STA L 44+76 RT
STA L 44+98 MED
STA RPC 14+03 RT
STA RPC 18+22 RT
STA RPC 19+01 LT
STA Y2 12+30 LT
STA RPD 20+24 RT

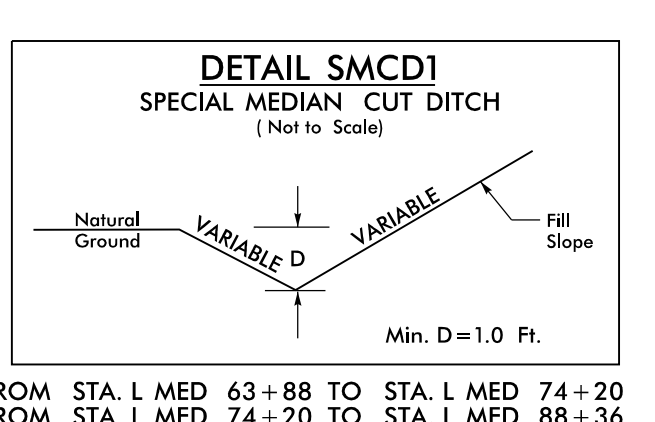

FROM STA. L MED 63+88 TO STA. L MED 74+20
FROM STA. L MED 74+20 TO STA. L MED 88+36

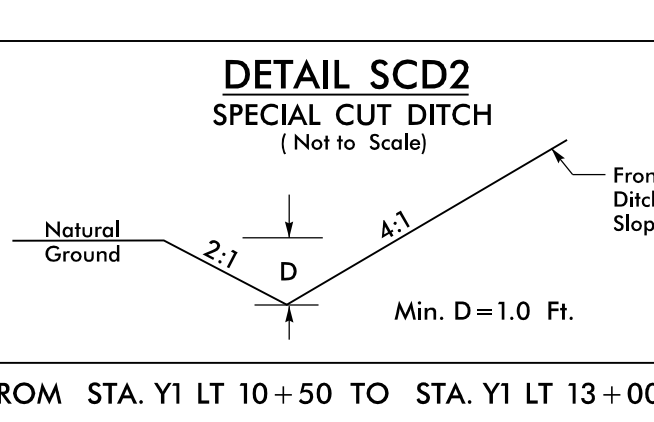

FROM STA. Y1 LT 10+50 TO STA. Y1 LT 13+00

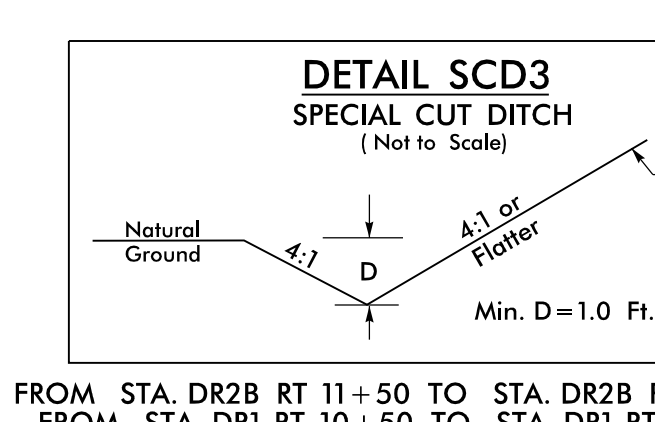

FROM STA. DR2B RT 11+50 TO STA. DR2B RT 14+00
FROM STA. DR1 RT 10+50 TO STA. DR1 RT 13+05
FROM STA. Y1 RT 13+50 TO STA. Y1 RT 16+00
FROM STA. Y1 RT 18+50 TO STA. Y1 RT 20+00
FROM STA. Y1 RT 25+00 TO STA. Y1 RT 27+00

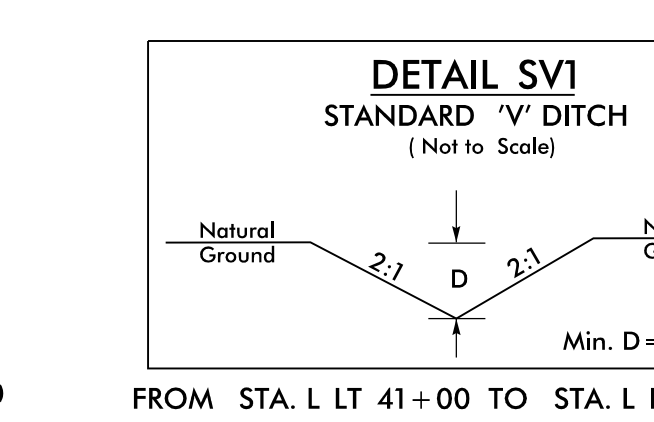

FROM STA. L LT 41+00 TO STA. L LT 41+50

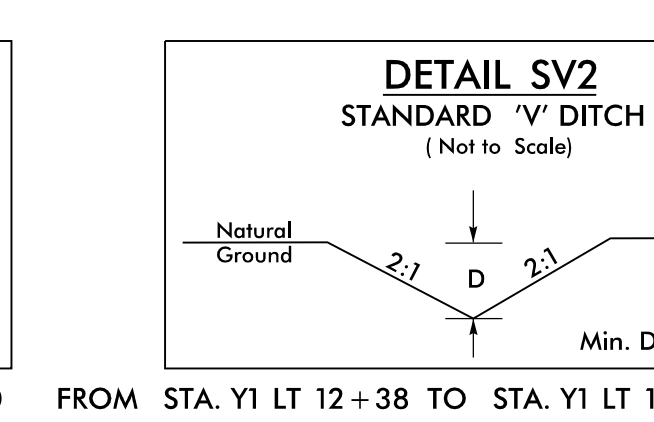

FROM STA. Y1 LT 12+38 TO STA. Y1 LT 13+00 (Tail Ditch)

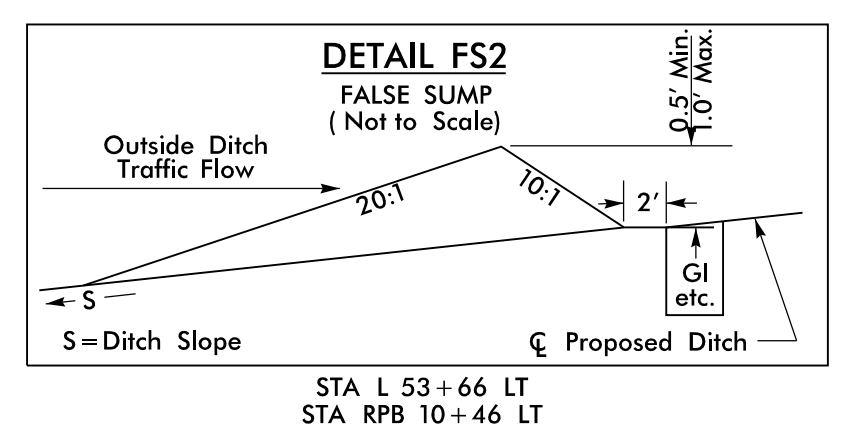

STA L 53+66 LT
STA RPB 10+46 LT
STA RPB 10+19 LT
STA RPB 35+61 RT
STA RPB 38+62 RT
STA L 48+77 MED
STA L 63+72 MED
STA L 67+74 MED
STA L 83+72 RT
STA L 88+15 RT

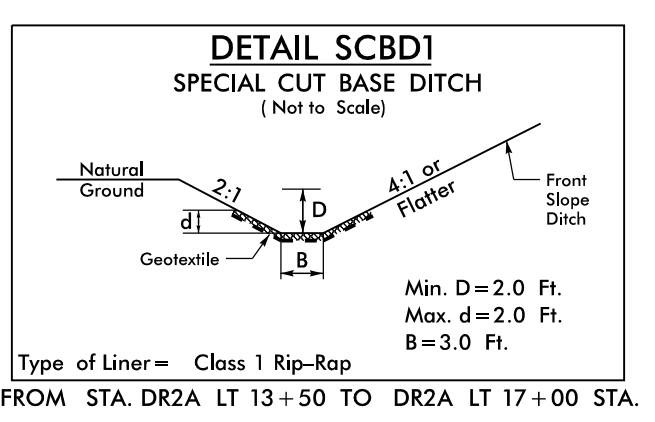

FROM STA. DR2A LT 13+50 TO DR2A LT 17+00 STA.

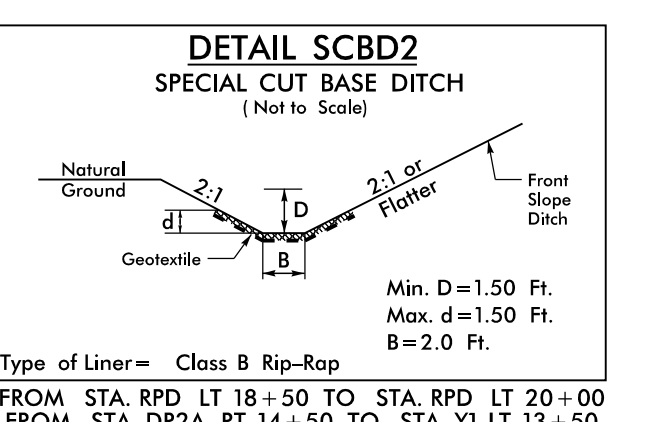

FROM STA. RPD LT 18+50 TO STA. RPD LT 20+00
FROM STA. DR2A RT 14+50 TO STA. Y1 LT 13+50

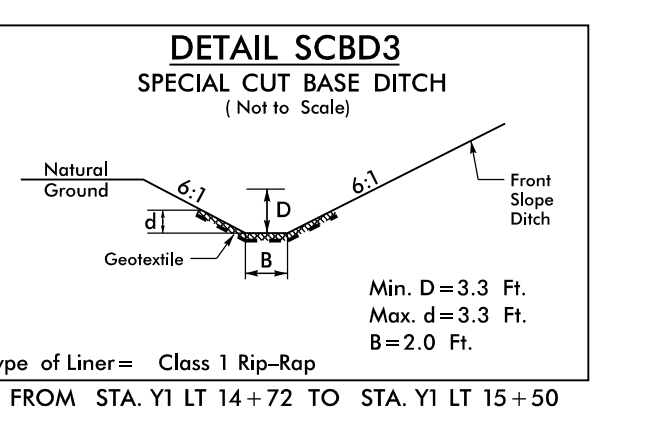

FROM STA. Y1 LT 14+72 TO STA. Y1 LT 15+50

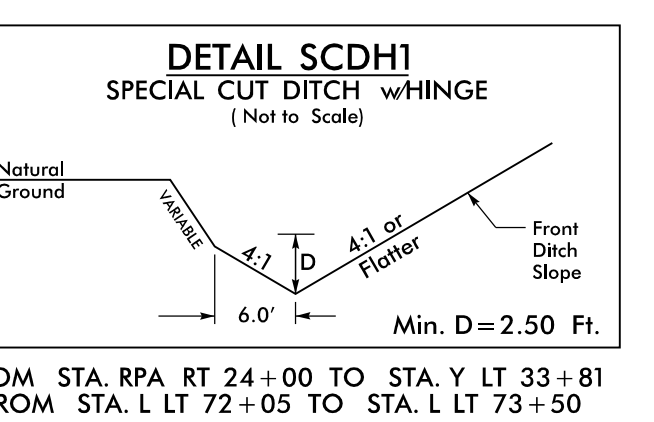

FROM STA. RPA RT 24+00 TO STA. Y LT 33+81
FROM STA. L LT 72+05 TO STA. L LT 73+50

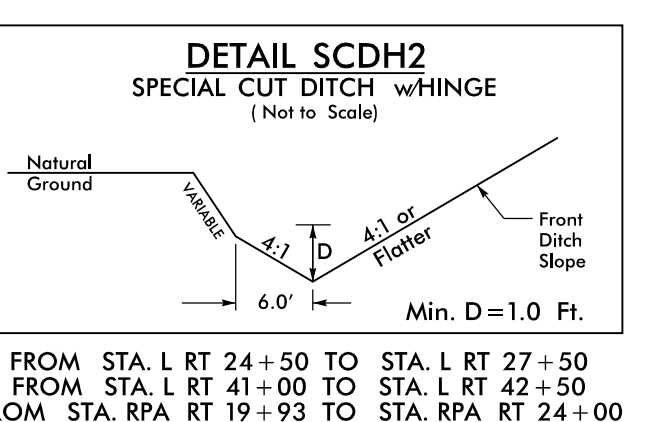

FROM STA. L RT 24+50 TO STA. L RT 27+50
FROM STA. L RT 41+00 TO STA. L RT 42+50
FROM STA. RPA RT 19+93 TO STA. RPA RT 24+00

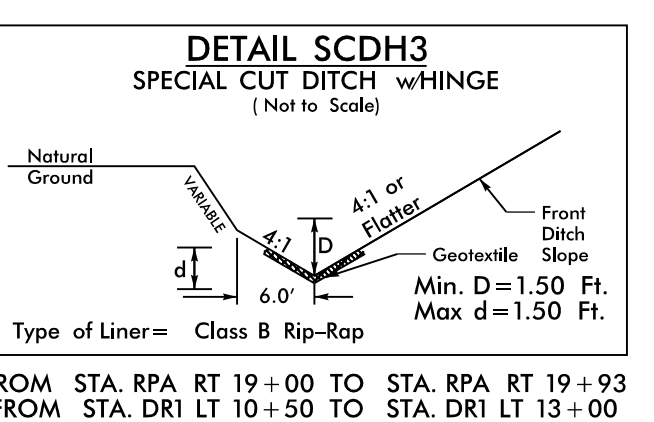

FROM STA. RPA RT 19+00 TO STA. RPA RT 19+93
FROM STA. DR1 LT 10+50 TO STA. DR1 LT 13+00

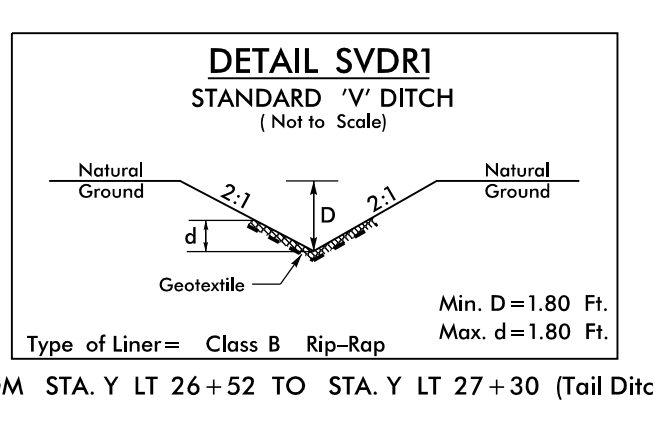

FROM STA. Y LT 26+52 TO STA. Y LT 27+30 (Tail Ditch)

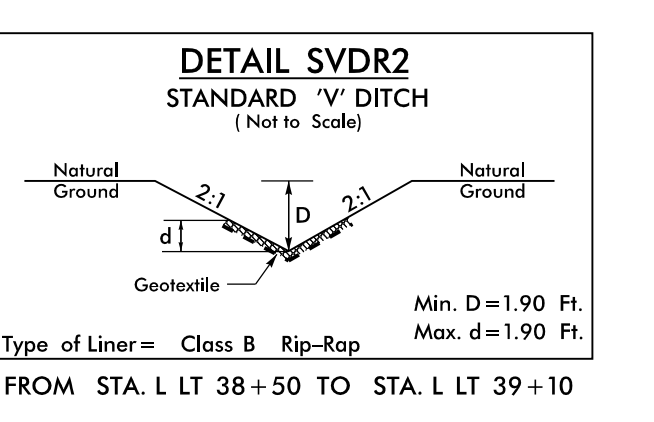

FROM STA. L LT 38+50 TO STA. L LT 39+10

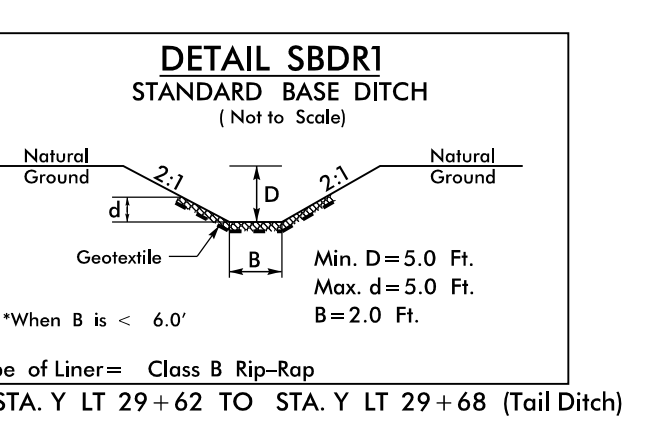

FROM STA. Y LT 29+62 TO STA. Y LT 29+68 (Tail Ditch)

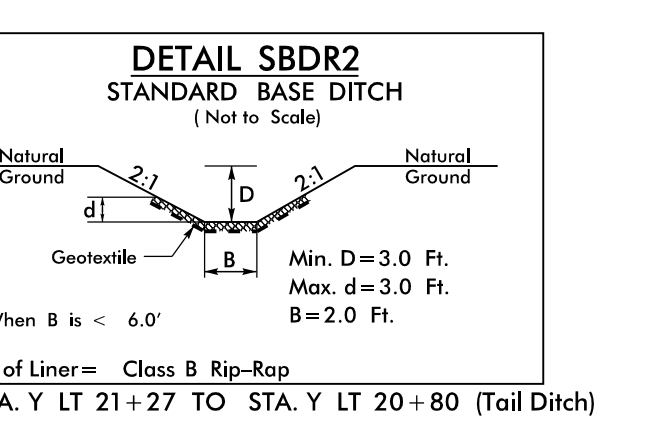

FROM STA. Y LT 21+27 TO STA. Y LT 20+80 (Tail Ditch)

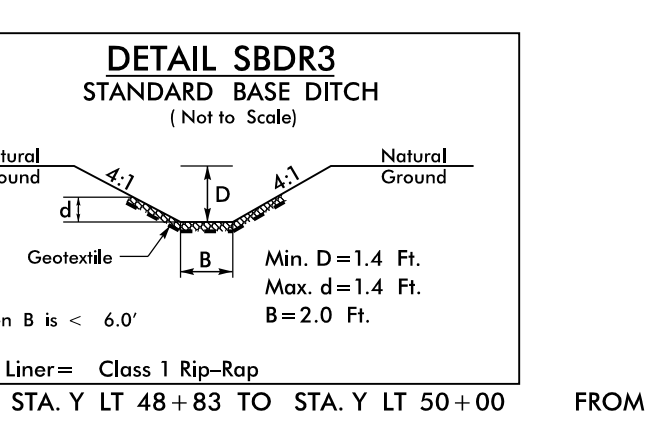

FROM STA. Y LT 48+83 TO STA. Y LT 50+00

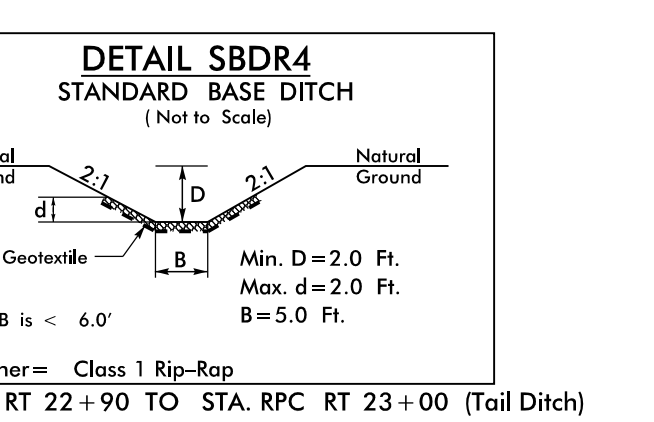

FROM STA. RPC RT 22+90 TO STA. RPC RT 23+00 (Tail Ditch)

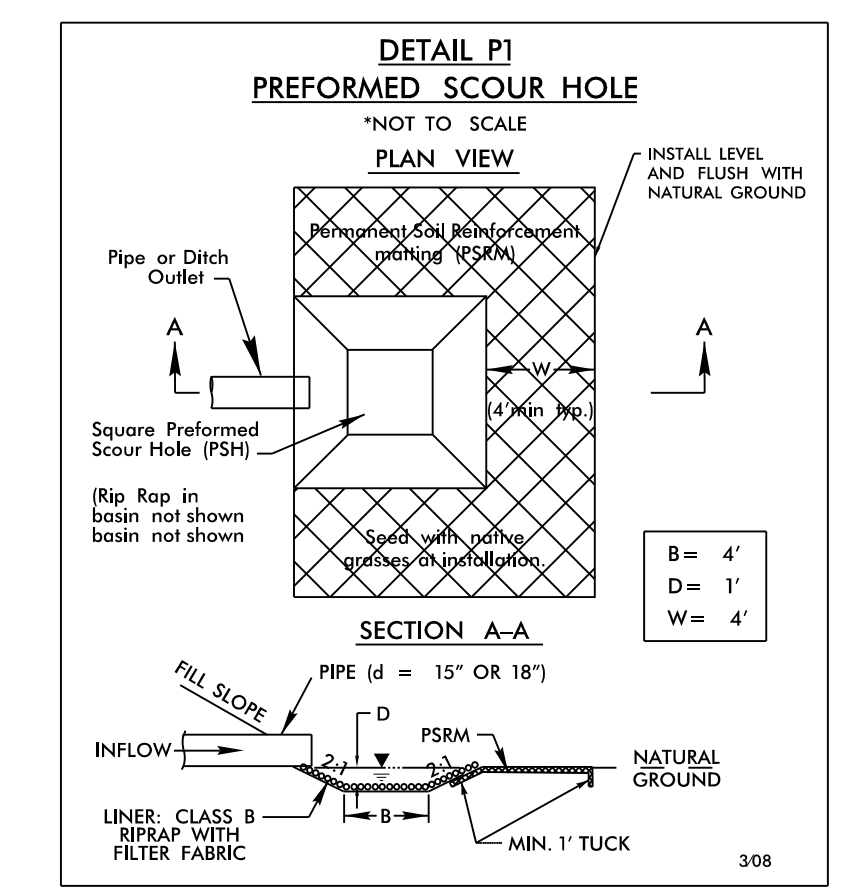

-L- STA 36+90 (LT)
-Y- STA 28+50 (RT)
-Y- STA 38+93 (RT)
-RPC- STA 21+00 (RT)

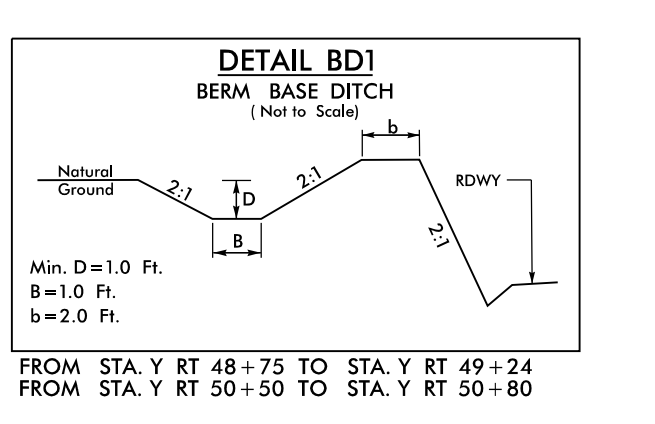

FROM STA. Y RT 48+75 TO STA. Y RT 49+24
FROM STA. Y RT 50+50 TO STA. Y RT 50+80

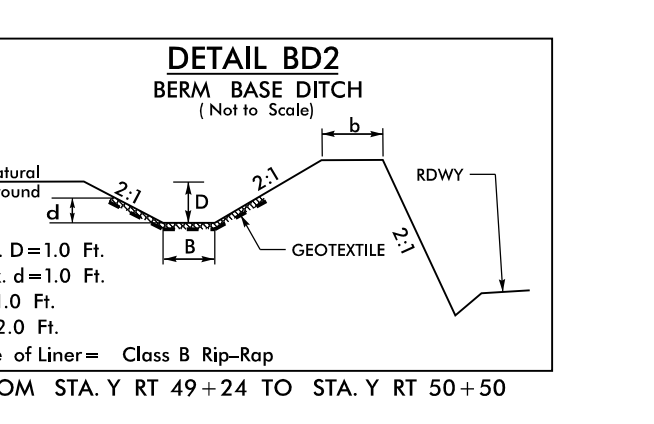

FROM STA. Y RT 49+24 TO STA. Y RT 50+50

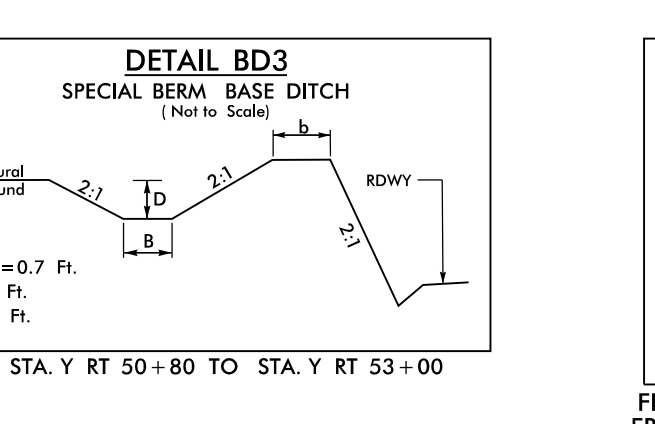

FROM STA. Y RT 50+80 TO STA. Y RT 53+00

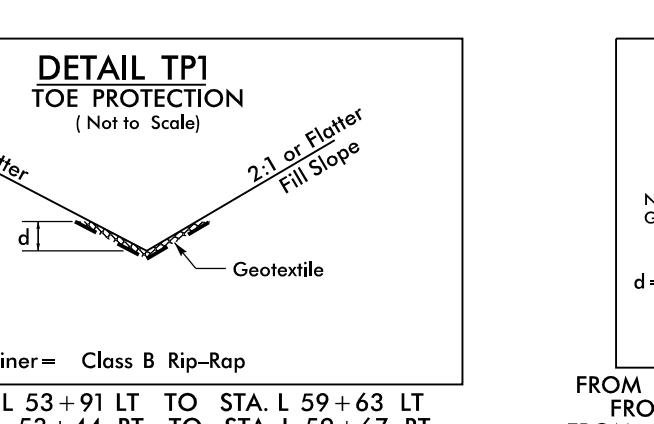

FROM STA. L 53+91 LT TO STA. L 59+63 LT
FROM STA. L 53+44 RT TO STA. L 59+67 RT
FROM STA. RPD 24+26 RT TO STA. RPD 26+12 RT

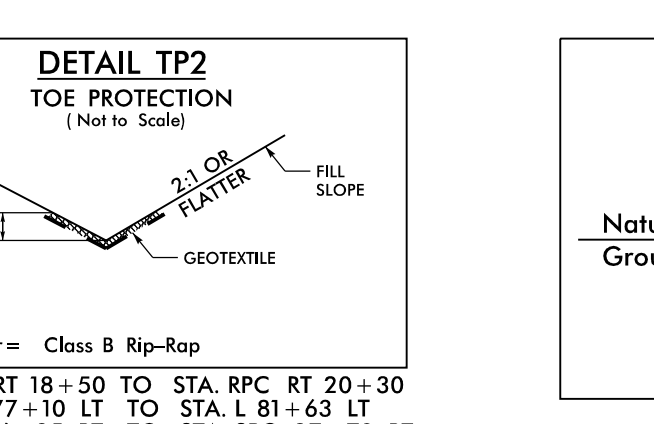

FROM STA. RPC RT 18+50 TO STA. RPC RT 20+30
FROM STA. L 77+10 LT TO STA. L 81+63 LT
FROM STA. SPC 26+25 RT TO STA. SPC 27+70 RT

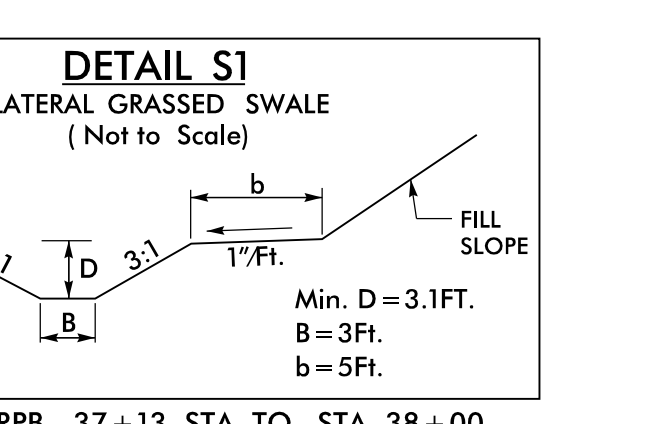

FROM -RPB- 37+13 STA. TO STA. 38+00