

NOTES:

STIRRUPS IN CAP MAY BE SHIFTED AS NECESSARY TO CLEAR ANCHOR BOLTS.

HOOKS ON V1 BARS MAY BE TURNED AS NECESSARY FOR PLACING REINFORCING STEEL.

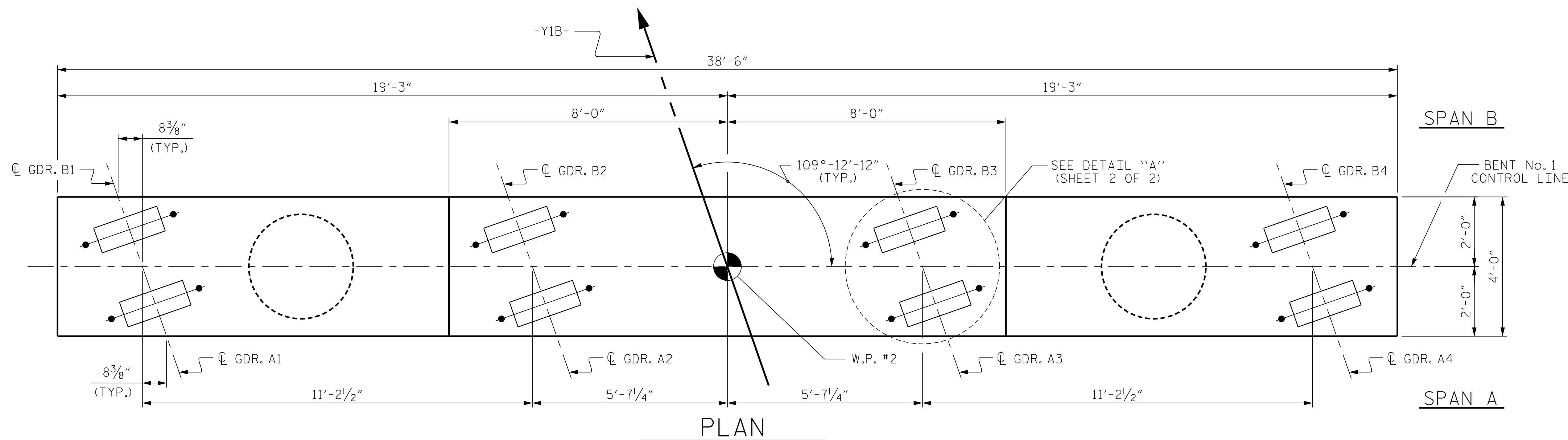

PLAN

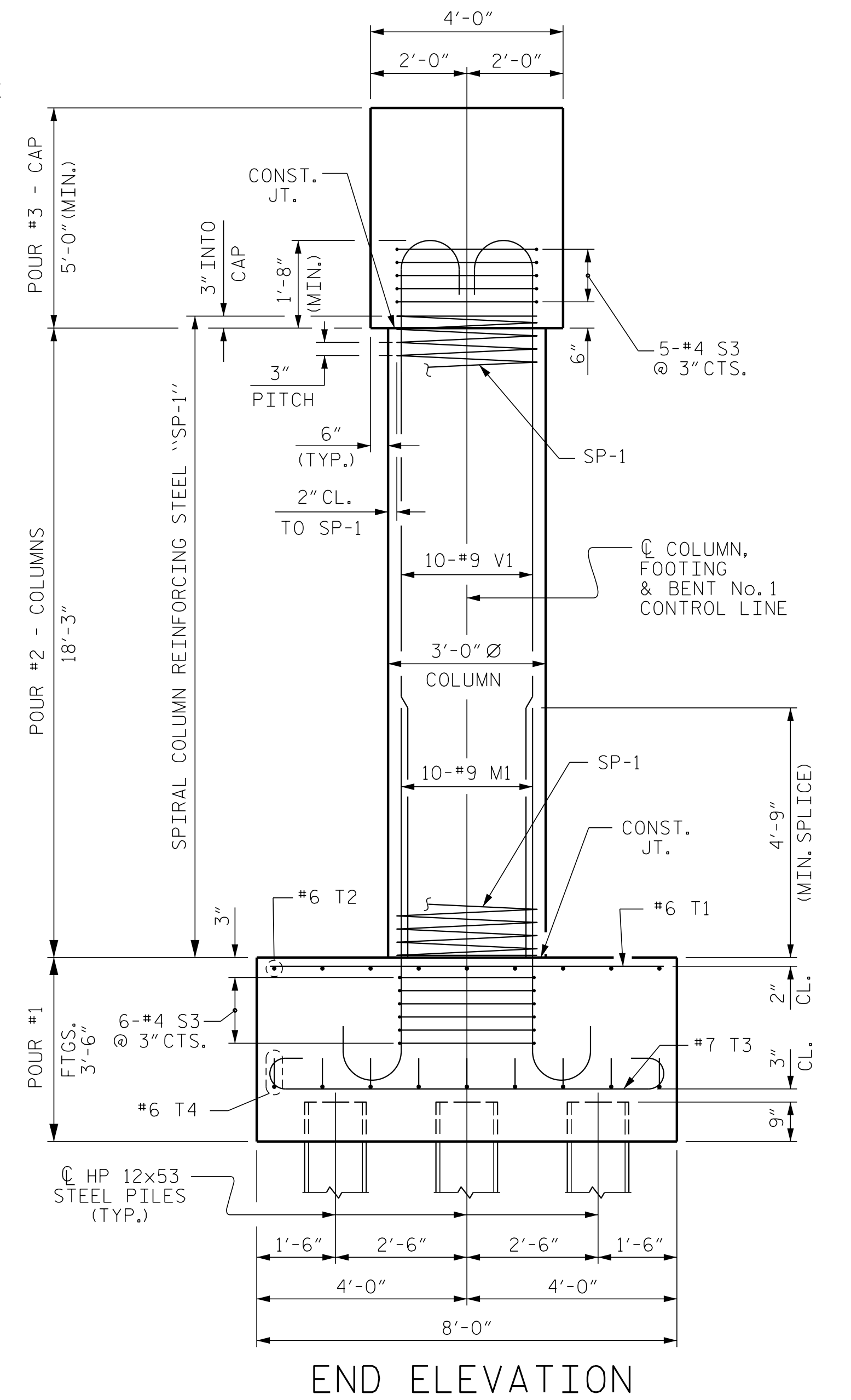

END ELEVATION

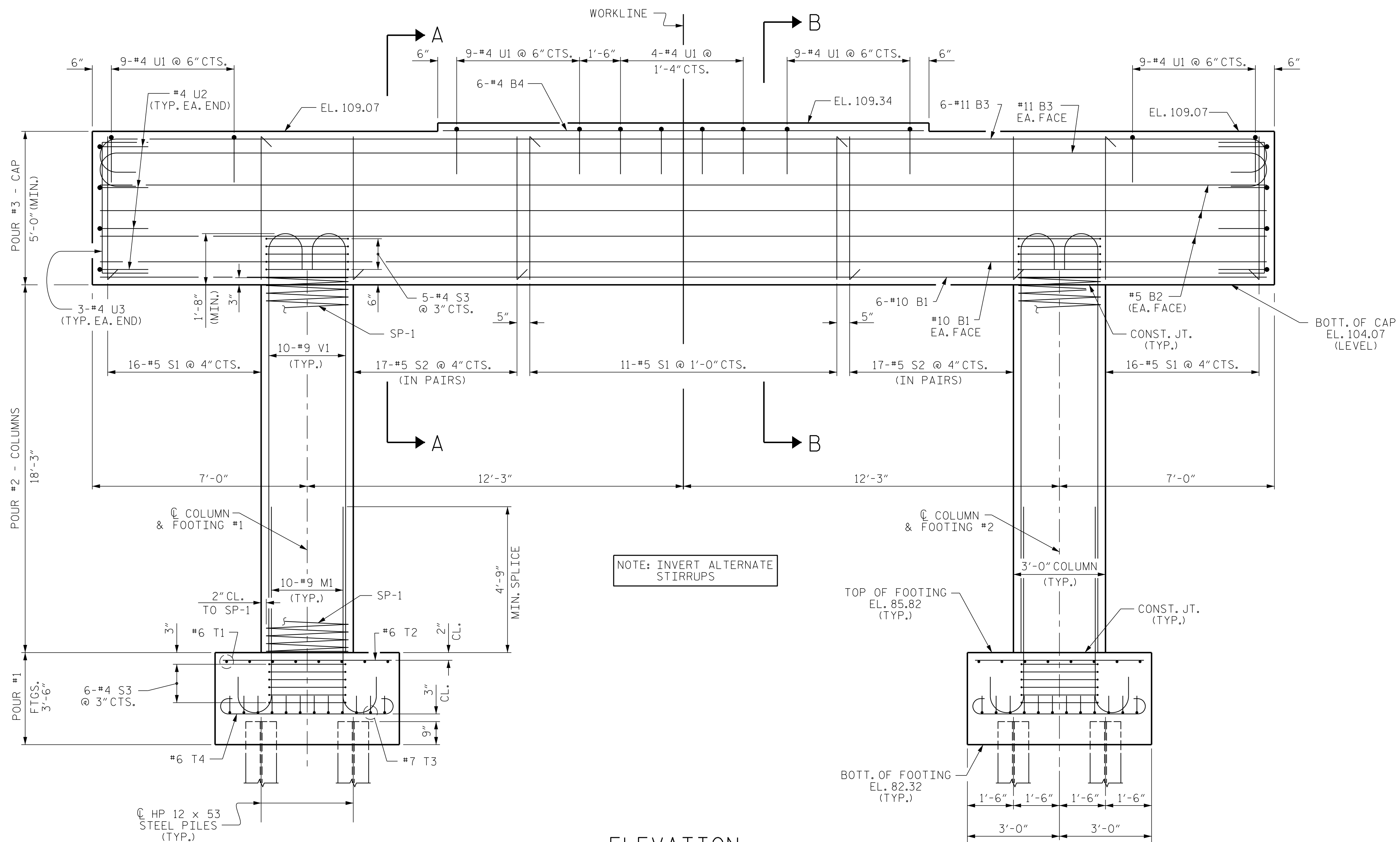

ELEVATION

PILE PLACEMENT, REINFORCING STEEL AND DIMENSIONS ARE TYPICAL FOR EACH FOOTING AND COLUMN.

NOTE: INVERT ALTERNATE STIRRUPS

PROJECT NO. R-5797
COLUMBUS COUNTY
 STATION: 30+65.33 -Y1B-
 SHEET 1 OF 2

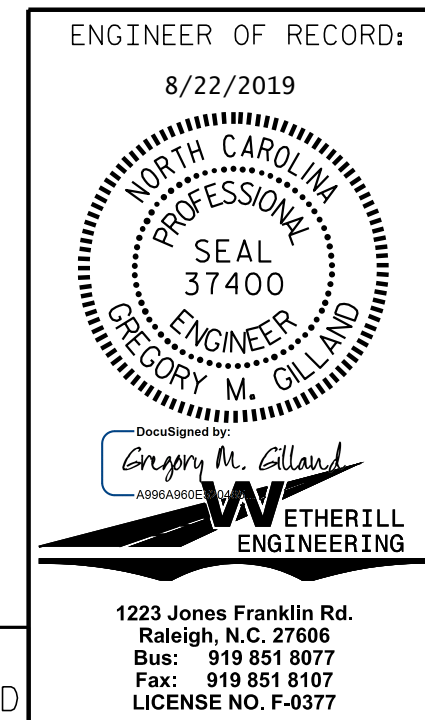

ENGINEER OF RECORD: 8/22/2019 GREGORY M. GILLILAND PROFESSIONAL SEAL 37400 LICENSE NO. F-0377		STATE OF NORTH CAROLINA DEPARTMENT OF TRANSPORTATION RALEIGH	
SUBSTRUCTURE BENT No. 1			
REVISIONS			
NO.	BY:	DATE:	SHEET NO.
1			S-25
2			TOTAL SHEETS 33

DOCUMENT NOT CONSIDERED FINAL UNLESS ALL SIGNATURES COMPLETED

PA:2017.17.18650.1-R-5797-Structures\06NR5797-SMJ_BT.dgn
 8/21/2019 1:42:48 PM

DRAWN BY: D. HODGE DATE: 3/19
 CHECKED BY: G.M. GILLAND DATE: 4/19