

8/17/99

DETAIL RCD

WETHERILL ENGINEERING
 1223 Jones Franklin Rd.
 Raleigh, N.C. 27606
 License No. F-0377
 Bus: 919 851 8077
 Fax: 919 851 8107

TRANSPORTATION PLANNING/DESIGN - BRIDGE/STRUCTURE DESIGN
 CIVIL/SITE DESIGN - GIS/GPS - CONSTRUCTION OBSERVATION

**DOCUMENT NOT CONSIDERED FINAL
 UNLESS ALL SIGNATURES COMPLETED**

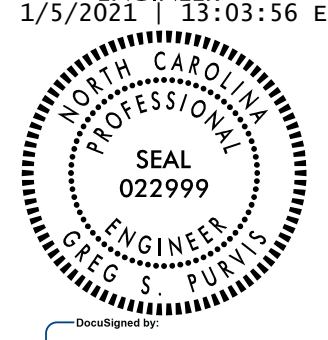
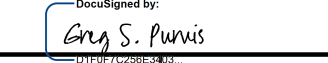
PROJECT REFERENCE NO. R-5797	SHEET NO. 2B-4
ROADWAY DESIGN ENGINEER 1/5/2021 13:03:56 EST	
	
	

SCALE : 1" = 25'

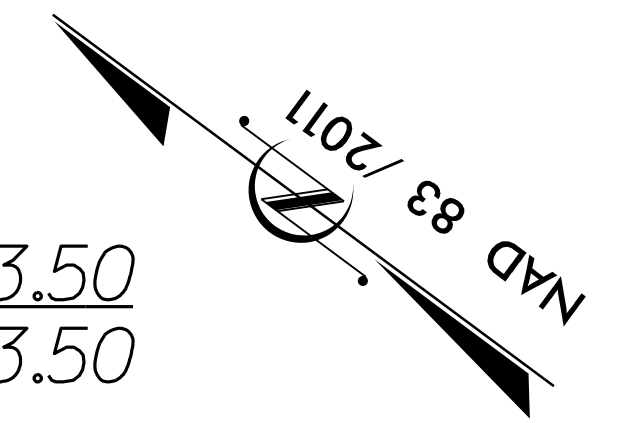

REVISIONS

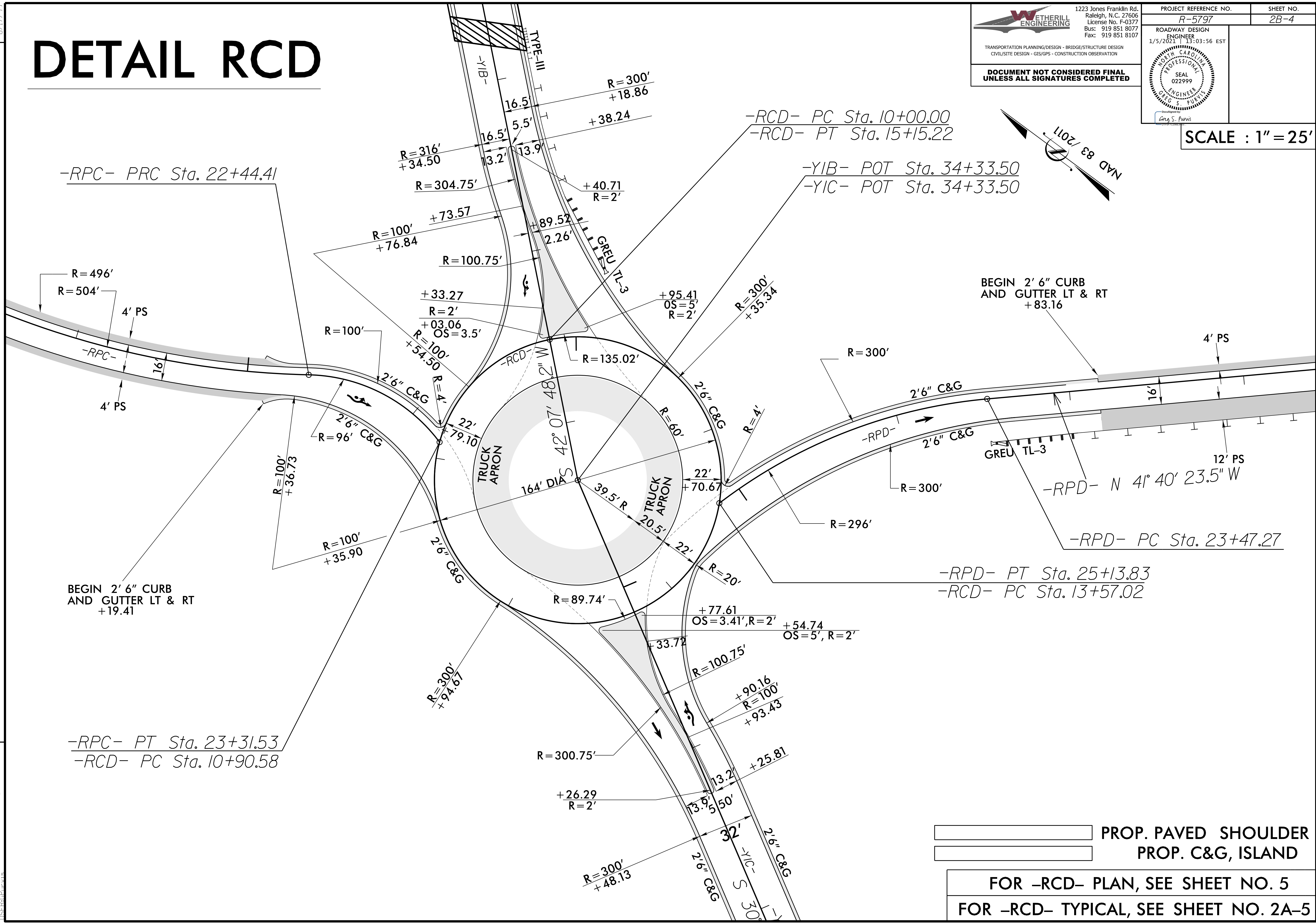

BEGIN 2' 6" CURB
 AND GUTTER LT & RT
 +19.41

-RPC- PT Sta. 23+31.53
 -RCD- PC Sta. 10+90.58

-RCD- PC Sta. 10+00.00
 -RCD- PT Sta. 15+15.22

-YIB- POT Sta. 34+33.50
 -YIC- POT Sta. 34+33.50

BEGIN 2' 6" CURB
 AND GUTTER LT & RT
 +83.16

-RPD- PT Sta. 25+13.83
 -RCD- PC Sta. 13+57.02

-RPD- PC Sta. 23+47.27

PROP. PAVED SHOULDER
 PROP. C&G, ISLAND

FOR -RCD- PLAN, SEE SHEET NO. 5
 FOR -RCD- TYPICAL, SEE SHEET NO. 2A-5

12/9/2020 08:57:97_Rdy_PSH_02B-4.dgn