

5/14/2021

PAVEMENT SCHEDULE			
(FINAL PAVEMENT DESIGN)			
C1	PROP. APPROX. 3" ASPHALT CONCRETE SURFACE COURSE, TYPE S9.5B, AT AN AVERAGE RATE OF 165 LBS. PER SQ. YD. IN EACH OF TWO LAYERS.	R3	12" CONCRETE TRUCK APRON
C2	PROP. VAR. DEPTH ASPHALT CONCRETE SURFACE COURSE, TYPE S9.5B, AT AN AVERAGE RATE OF 110 LBS. PER SQ. YD. PER 1" DEPTH. TO BE PLACED IN LAYERS NOT LESS THAN 1 1/2" IN DEPTH.	R4	8"x18" CONCRETE CURB
C3	PROP. APPROX. 3" ASPHALT CONCRETE SURFACE COURSE, TYPE S9.5C, AT AN AVERAGE RATE OF 168 LBS. PER SQ. YD. IN EACH OF TWO LAYERS.	R5	EXPRESSWAY GUTTER
C4	PROP. VAR. DEPTH ASPHALT CONCRETE SURFACE COURSE, TYPE S9.5C, AT AN AVERAGE RATE OF 112 LBS. PER SQ. YD. PER 1" DEPTH. TO BE PLACED IN LAYERS NOT TO EXCEED 2" IN DEPTH.	R6	SHOULDER BERM GUTTER
D1	PROP. APPROX. 4" ASPHALT CONCRETE INTERMEDIATE COURSE, TYPE I19.0C, AT AN AVERAGE RATE OF 456 LBS. PER SQ. YD.	R7	9"x12" CONCRETE CURB
D2	PROP. VAR. DEPTH ASPHALT CONCRETE INTERMEDIATE COURSE, TYPE I19.0C, AT AN AVERAGE RATE OF 114 LBS. PER SQ. YD. PER 1" DEPTH. TO BE PLACED IN LAYERS NOT LESS THAN 2 1/2" IN DEPTH OR GREATER THAN 4" IN DEPTH.	R8	4" CONCRETE ISLAND COVER
E1	PROP. APPROX. 4" ASPHALT CONCRETE BASE COURSE, TYPE B25.0C, AT AN AVERAGE RATE OF 456 LBS. PER SQ. YD.	R9	5" MONOLITHIC ISLAND (KEYED IN)
E2	PROP. APPROX. 5 1/2" ASPHALT CONCRETE BASE COURSE, TYPE B25.0C, AT AN AVERAGE RATE OF 627 LBS. PER SQ. YD.	T	EARTH MATERIAL
E3	PROP. VAR. DEPTH ASPHALT CONCRETE BASE COURSE, TYPE B25.0C, AT AN AVERAGE RATE OF 114 LBS. PER SQ. YD. PER 1" DEPTH. TO BE PLACED IN LAYERS NOT LESS THAN 3" IN DEPTH OR GREATER THAN 5 1/2" IN DEPTH.	U	EXISTING PAVEMENT
J1	PROP. 6" AGGREGATE BASE COURSE.	V1	INCIDENTAL MILLING
J2	PROP. 8" AGGREGATE BASE COURSE.	W	VARIABLE DEPTH ASPHALT PAVEMENT (SEE WEDGING DETAILS)
R1	1'-6" CONCRETE CURB AND GUTTER.	X	ARTIFICIAL TURF (SEE SPECIAL PROVISION IN CONTRACT)
R2	2'-6" CONCRETE CURB AND GUTTER.	Y	MILLED RUMBLE STRIPS

NOTES TO CONTRACTOR

Perform the work in accordance with Section 607 of the January 2018 North Carolina Department of Transportation Standard Specifications for Roads and Structures. Resurfacing will be accomplished at the same time as the milling operation.

BEGINNING OF PROJECT

75' INCIDENTAL MILLING

EXISTING PAVEMENT

3" V1

3" U

NOTE: UTILIZE INCIDENTAL MILLING TO MAKE PAVEMENT TIE-INS

- L- STA. 14+88.04 TO -L- STA. 15+63.04
- L- STA. 67+25.00 TO -L- STA. 68+00.00
- Y2- STA. 15+00.00 TO -Y2- STA. 15+75.00
- Y1A- STA. 11+00.00 TO -Y1A- STA. 11+75.00
- Y2- STA. 17+25.00 TO -Y2- STA. 18+00.00

ROADWAY DESIGN ENGINEER 2/3/2021 	OVERLAY PAVEMENT DESIGN ENGINEER 2/3/2021 	PAVEMENT DESIGN ENGINEER 2/3/2021
--	---	---

DOCUMENT NOT CONSIDERED FINAL UNLESS ALL SIGNATURES COMPLETED

1223 Jones Franklin Rd.
Raleigh, N.C. 27606
License No. F-0377
Bus: 919 851 8077
Fax: 919 851 8107

TRANSPORTATION PLANNING/DESIGN - BRIDGE/STRUCTURE DESIGN
CIVIL/SITE DESIGN - GIS/GPS - CONSTRUCTION OBSERVATION

SINCE 1881 **Prepared in the Office of:**
FROEHLING & ROBERTSON, INC.
 Engineering Stability Since 1881
 310 Hubert Street
 Raleigh, North Carolina 27603-2302
 License No. F-0266
 Bus: 919.828.3441 Fax: 919.828.5751

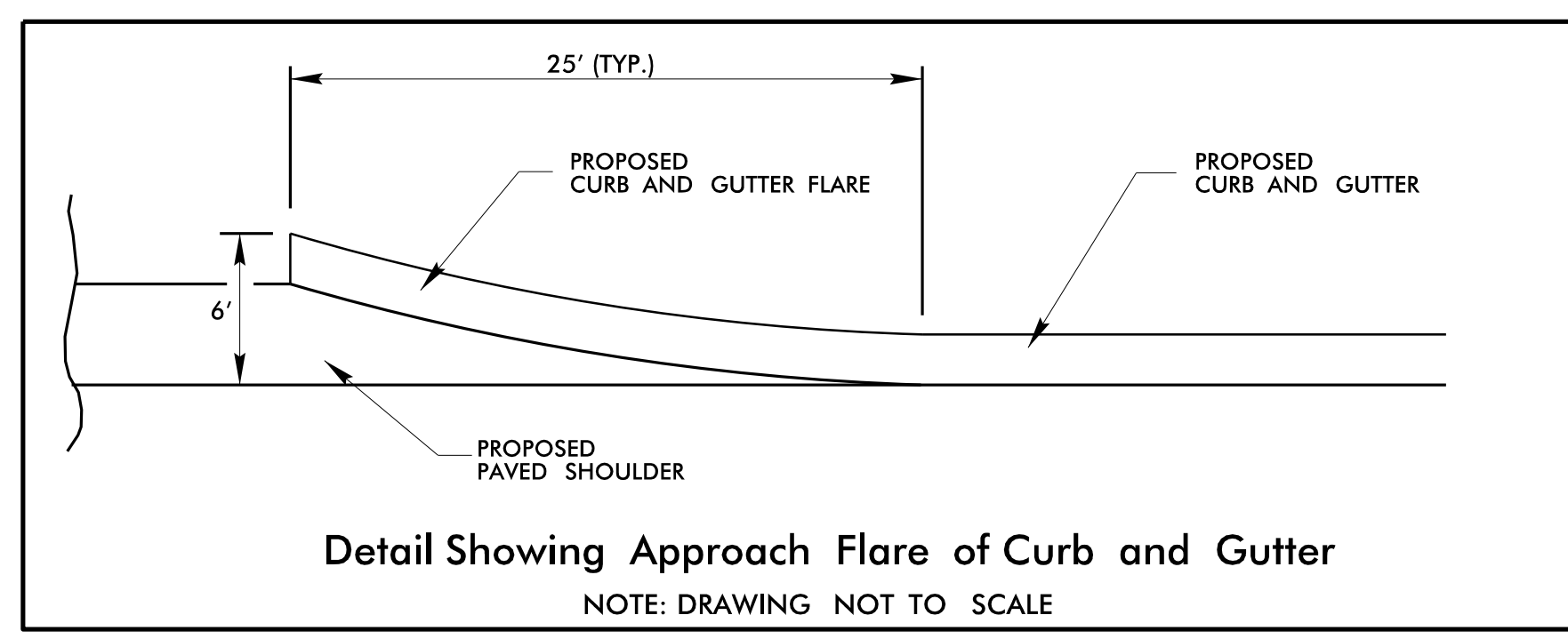
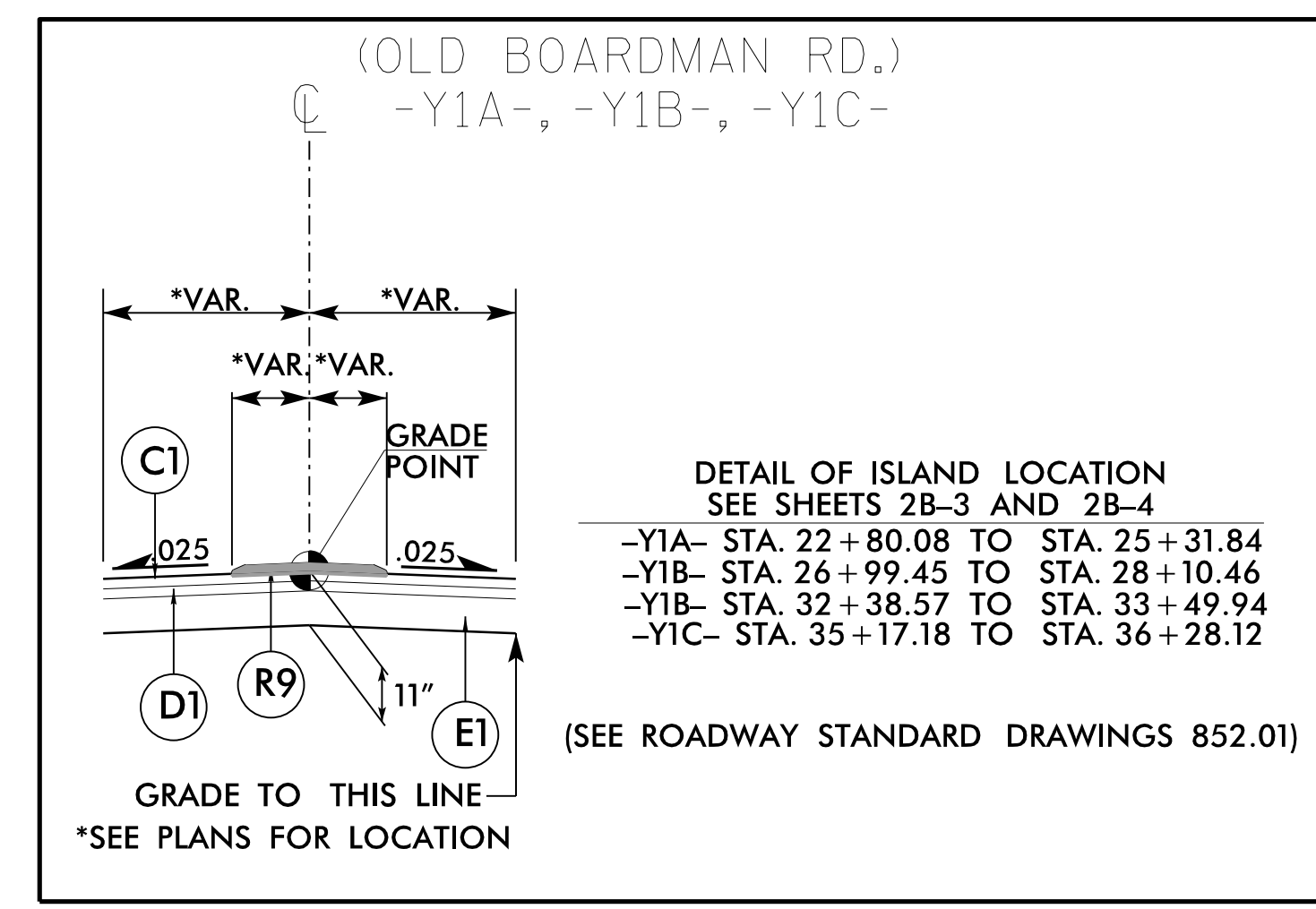

NOTE: PAVEMENT EDGE SLOPES ARE 1:1 UNLESS SHOWN OTHERWISE.

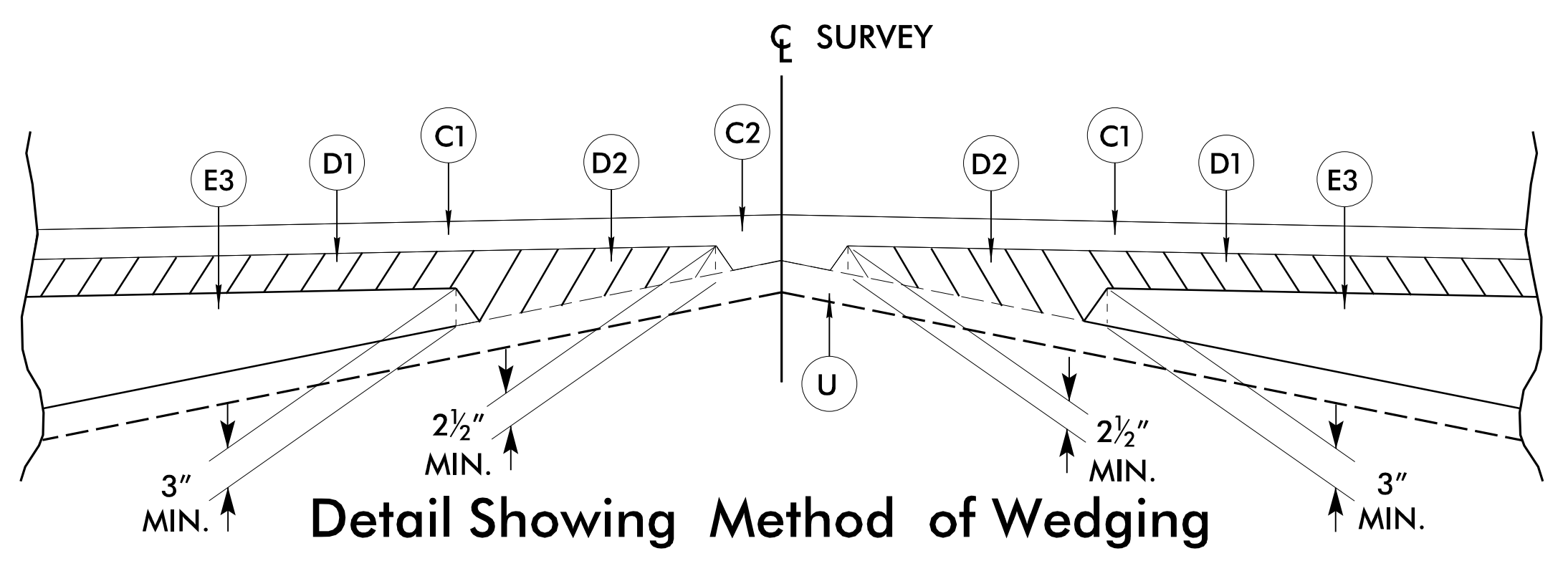
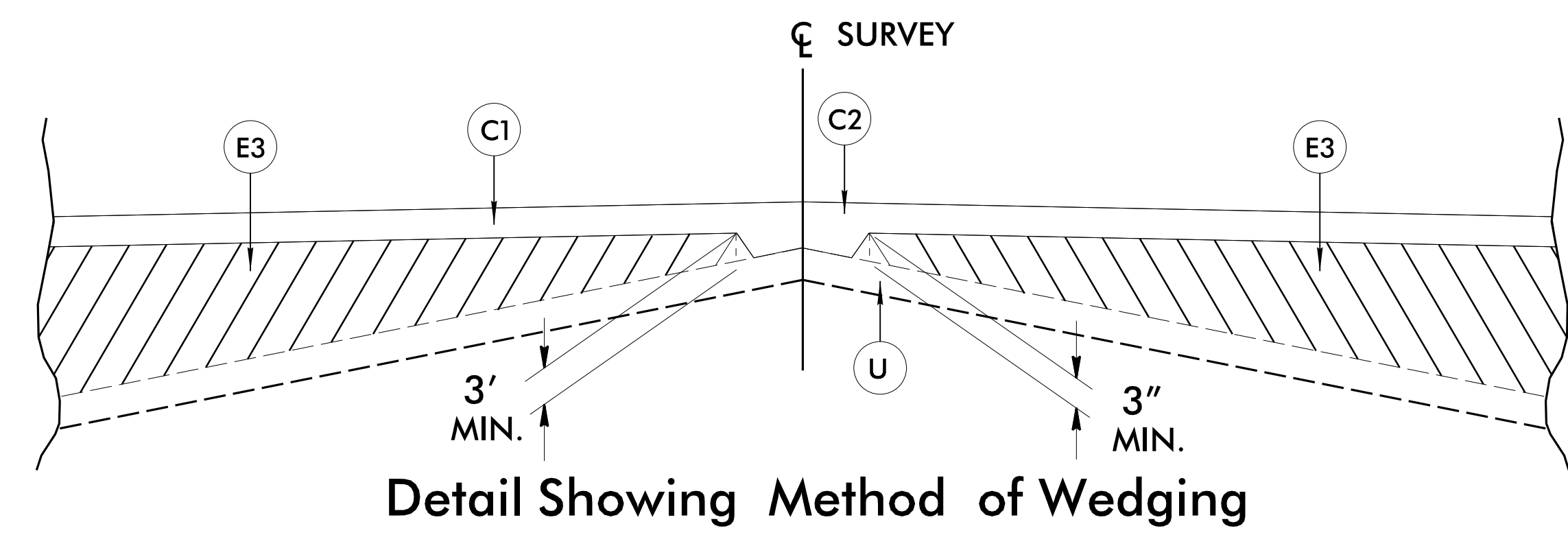
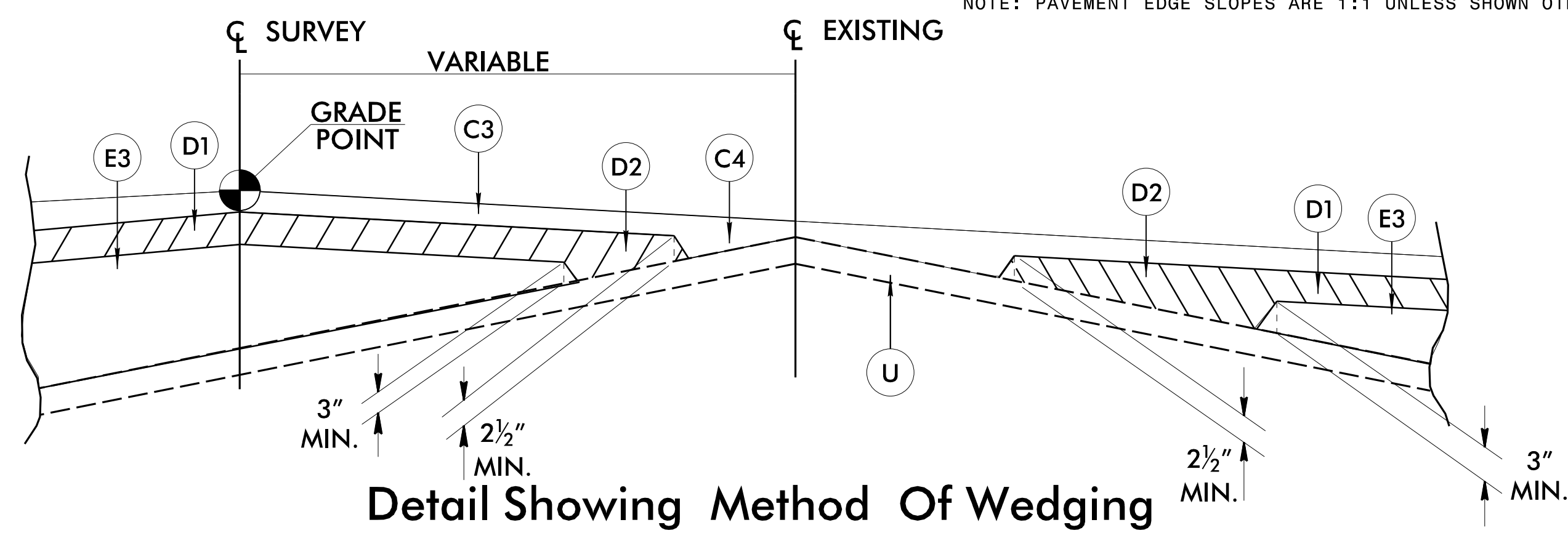

5/13/2021 10:21:57 AM PSH-02A-1.dgn