

NOTES:

- 1) DETAIL DOES NOT APPLY TO OGAFc AND ULTRA-THIN BONDED WEARING COURSE.
- 2) BACKFILL SHOULDER WITH APPROVED MATERIAL.
- 3) THE SHOULDER WEDGE DEVICE MAY BE DISENGAGED AT PAVED DRIVEWAYS AND SIDE STREETS.

STATE	PROJECT NO.	SHEET NO.	TOTAL SHEETS
N.C.	2021CPT.10.13.10901 2021CPT.10.13.20901 2021CPT.10.13.20902	19	
F.A. PROJECT NO.			

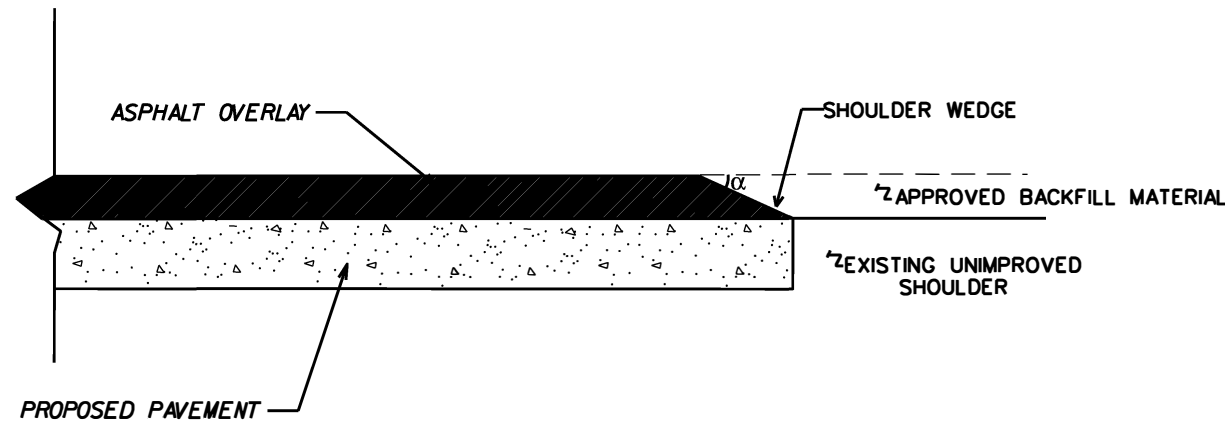

SHOULDER WEDGE DETAIL

(RESURFACING PROJECTS W/ WIDENING OR WITH EXISTING PAVED SHOULDER HAVING NO DROPOFFS)

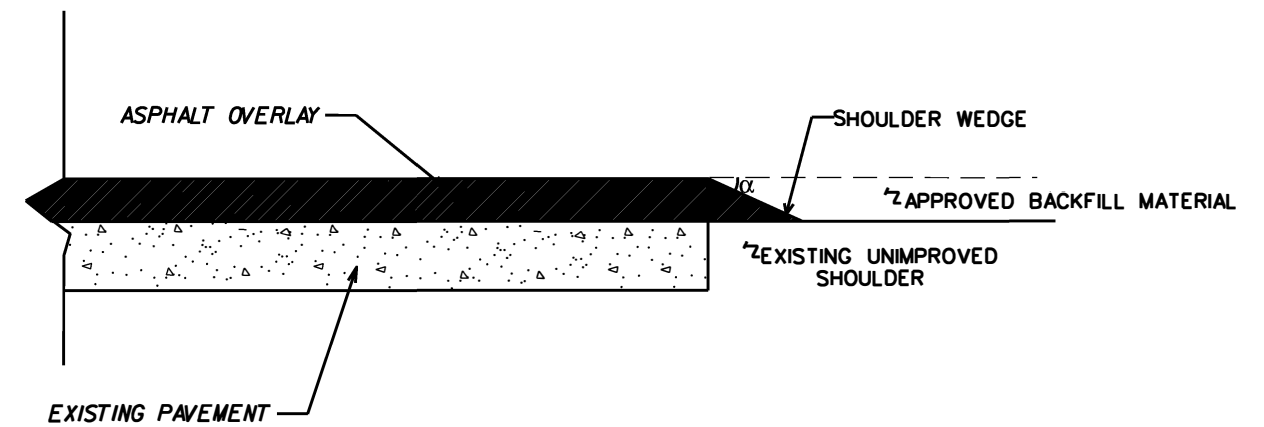

SHOULDER WEDGE DETAIL

(RESURFACING PROJECTS W/ NO WIDENING)

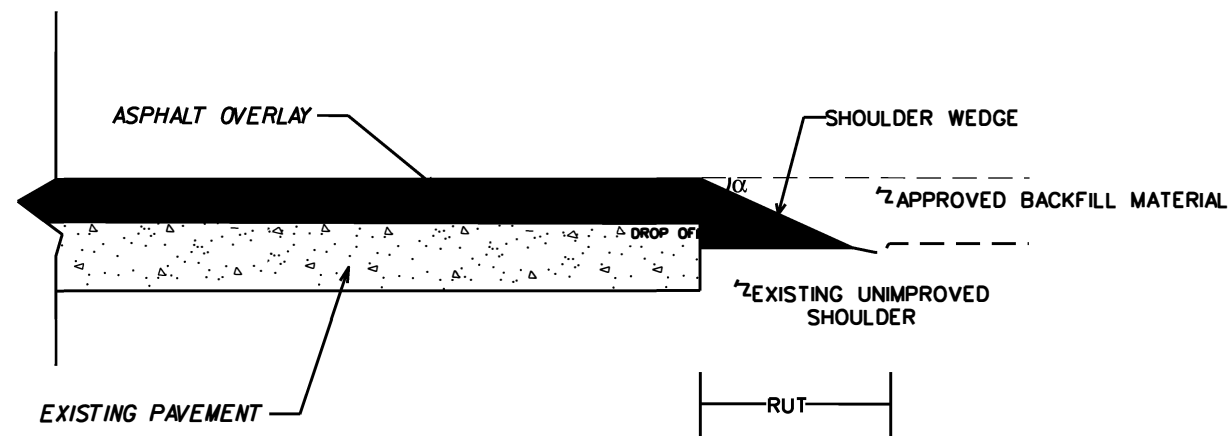

SHOULDER WEDGE DETAIL
(RESURFACING ADJACENT TO RUTTED SHOULDER)

$\alpha = 30$ DEGREES

SHOULDER WEDGE DETAILS			
SCALE	-NA-		REVISIONS
DATE	08/18		
DWG. BY	AMO		
DESIGN BY	AMO		
APPROVED	CLA		