

DATE: 2/27/2020
TIME: 3:55:00 PM

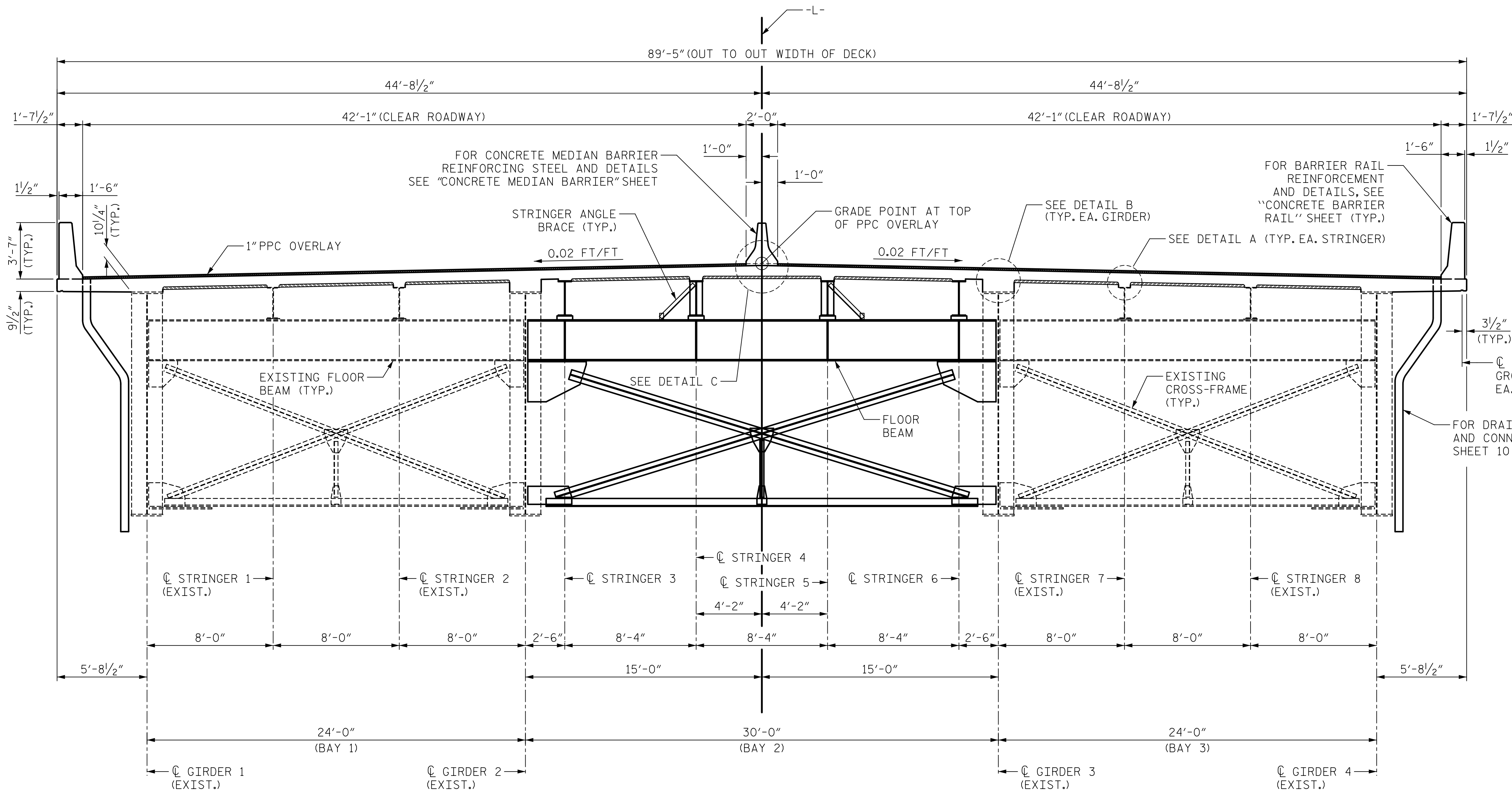

NOTES:

- FOR PPC OVERLAY DETAILS, SEE SHEET 10 OF 10.
- FOR INTERMEDIATE CROSSFRAMES, SEE SHEET 1 OF 10.
- FOR GIRDER BUILDUP, DETAIL B, SEE SHEET 1 OF 10.
- CONTRACTOR SHALL TINE THE DECK AND GROOVE THE PPC OVERLAY, FOR DETAILS, SEE SPECIAL PROVISIONS.

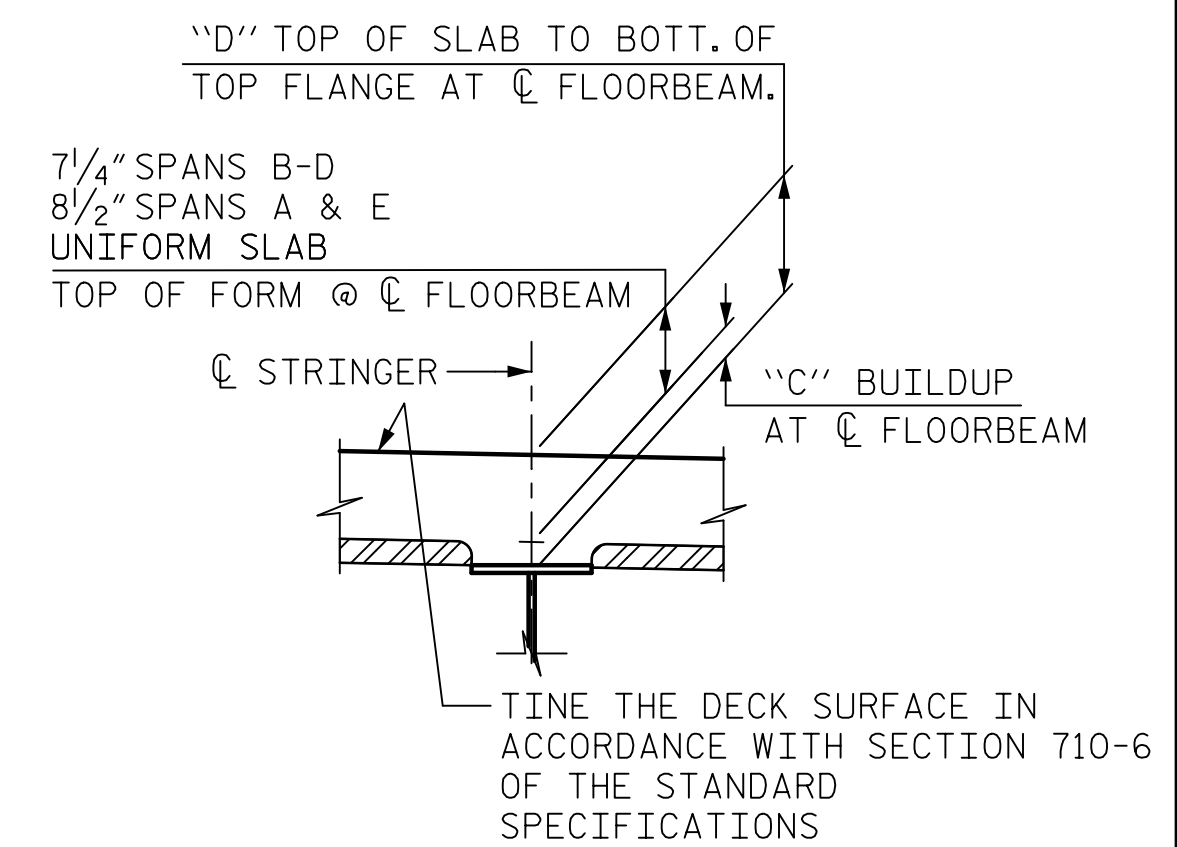

DETAIL A AT STRINGER

(PPC OVERLAY NOT SHOWN FOR CLARITY)
(DIMENSIONS SHOWN DO NOT INCLUDE PPC OVERLAY)

TYPICAL SECTION

(CROSSFRAMES SHOWN TYPICAL OF CROSSFRAMES AT BENTS)

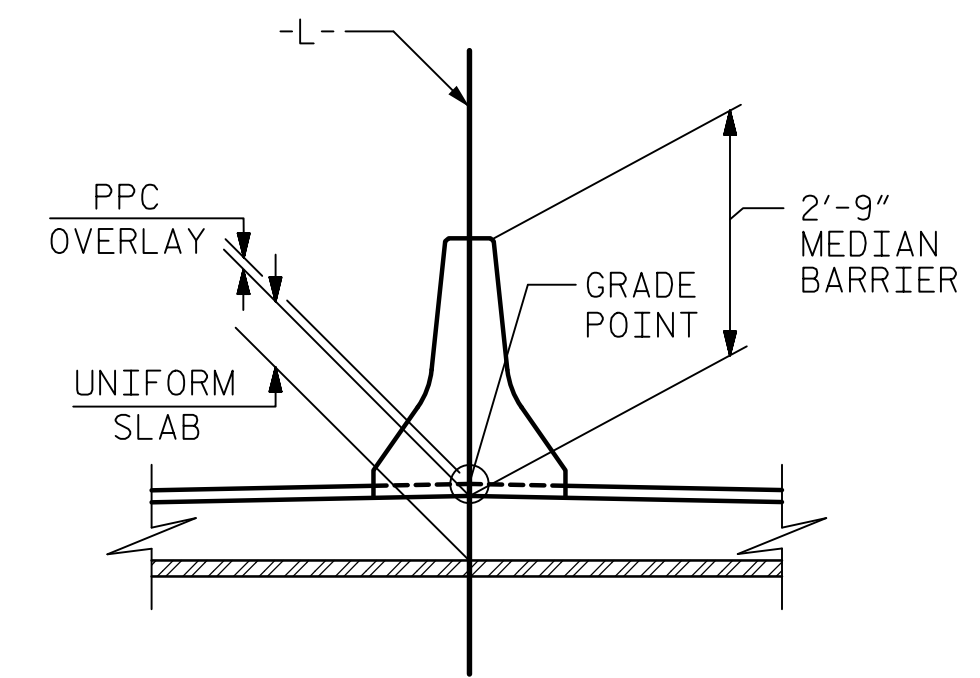

DETAIL C

THE GRADE POINT IS AT THE TOP OF THE PPC OVERLAY

ESTIMATED STRINGER BUILDUP DIM "C"								
STRINGER	BUILDUP AT CENTERLINE OF FLOORBEAM AT CROSSFRAME POINTS *							
	A1	A5	1	12	26	37	E1	E5
1 & 8	2 3/4"	2 1/4"	3 1/4"	3 3/4"	2 1/2"	4"	3 1/4"	2 1/2"
2 & 7	4 3/4"	4"	5"	5 1/2"	4 1/2"	5 3/4"	5 1/4"	4 1/2"
3 & 6	2 3/4"	2 1/4"	2 1/2"	3"	2"	3 1/4"	3 1/4"	2 1/2"
4 & 5	4 3/4"	4 1/4"	4 1/2"	5 1/4"	4"	5 1/4"	5 1/4"	4 1/2"

ESTIMATED STRINGER TOP OF SLAB TO BOTTOM OF TOP FLANGE DIM "D"								
STRINGER	BUILDUP AT CENTERLINE OF FLOORBEAM AT CROSSFRAME POINTS *							
	A1	A5	1	12	26	37	E1	E5
1 & 8	11 1/4"	10 3/4"	10 1/2"	11"	9 3/4"	11 1/4"	11 3/4"	11"
2 & 7	1'-1 1/4"	1'-0 1/2"	1'-0 1/4"	1'-0 3/4"	11 3/4"	1'-1"	1'-1 3/4"	1'-1"
3 & 6	11 1/4"	10 3/4"	9 3/4"	10 1/4"	9 1/4"	10 1/2"	11 3/4"	11"
4 & 5	1'-1 1/4"	1'-1 3/4"	11 3/4"	1'-0 1/2"	11 1/4"	1'-0 1/2"	1'-1 3/4"	1'-1"

* VALUES REPORTED TO NEAREST 1/4"

PROJECT NO. 15BPR.20
HENDERSON COUNTY
STATION: 35+30.22 -L-

SHEET 2 OF 10

AECOM
AECOM TECHNICAL SERVICES OF NC, INC.
701 CORPORATE CENTER DRIVE, SUITE 475
RALEIGH, NC 27607
(919) 854-6200 www.aecom.com
AECOM License No. F-0342

STATE OF NORTH CAROLINA
DEPARTMENT OF TRANSPORTATION
RALEIGH

SEAL
ENGINEER
JOHN E. SLOAN
2/28/2020

STATE OF NORTH CAROLINA
DEPARTMENT OF TRANSPORTATION
RALEIGH

SUPERSTRUCTURE
TYPICAL SECTION
FINAL STAGE
AND PPC OVERLAY

REVISIONS						SHEET NO.
NO.	BY:	DATE:	NO.	BY:	DATE:	S-24
1			3			TOTAL SHEETS
2			4			129

DOCUMENT NOT CONSIDERED
FINAL UNLESS ALL
SIGNATURES COMPLETED

DRAWN BY : S. STREDAK DATE : 4/2019
CHECKED BY : J. SLOAN DATE : 4/2019
DESIGNED BY : N. BROWN/D. TUTTLE DATE : 4/2019
DESIGN CHECKED BY : J. SLOAN/J. LIU DATE : 4/2019

USER: Merch/Resourced Drawings\AOL\DOT_ISS\BPR20_SMT\TSS2.dgn