

DATE: 2/27/2020
TIME: 3:16:28 PM

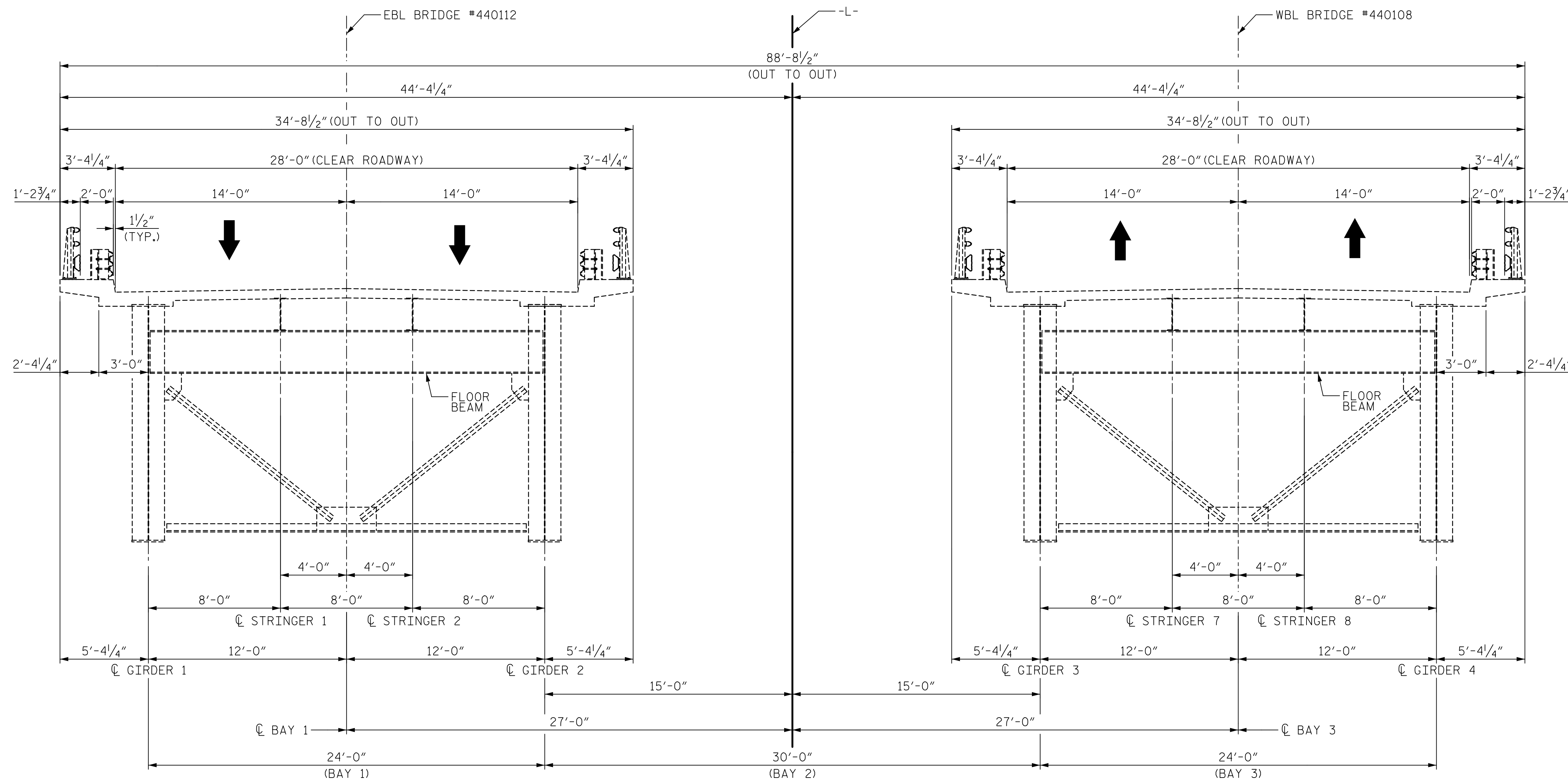

EXISTING STRUCTURE

PROJECT NO. 15BPR.20
HENDERSON COUNTY
 STATION: 35+30.22 -L-

SHEET 2 OF 12

LEGEND

- EXISTING
- PROPOSED
- ▨ DEMOLITION

DRAWN BY : H.T. ROSEMOND DATE : 11/2018
 CHECKED BY : J.E. SLOAN DATE : 11/2018
 DESIGNED BY : N. BROWN/D. TUTTLE DATE : 11/2018
 DESIGN CHECKED BY : J. SLOAN/J. LIU DATE : 11/2018

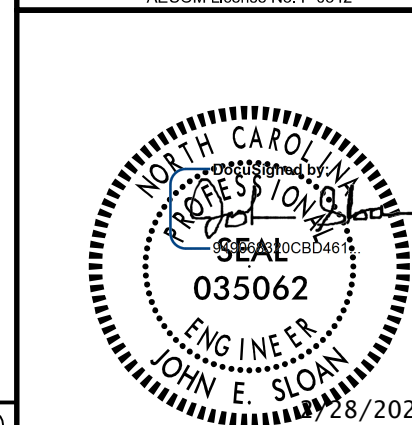

STATE OF NORTH CAROLINA
 DEPARTMENT OF TRANSPORTATION
 RALEIGH

SUPERSTRUCTURE
 DEMOLITION
 & CONSTRUCTION
 SEQUENCE
 EXISTING STRUCTURE

REVISIONS

NO.	BY:	DATE:	NO.	BY:	DATE:
1			3		
2			4		

SHEET NO.
 S-12
 TOTAL SHEETS
 129

DOCUMENT NOT CONSIDERED
 FINAL UNLESS ALL
 SIGNATURES COMPLETED

USER: Merch Rosemond Drawings\01_023_15BPR.20_S12.dwg