

ECONOLITE ASC/3-2070 OVERLAP PROGRAMMING DETAIL

(program controller as shown)

- From Main Menu select **2. CONTROLLER**
- From CONTROLLER Submenu select **2. VEHICLE OVERLAPS**

OVERLAP G

Toggle to "Overlap G"

Select TMG VEH OVLP [G] and 'NORMAL'

```

TMG VEH OVLP...[G] TYPE: .....NORMAL
PHASES 1 2 3 4 5 6 7 8 9 0 1 2 3 4 5 6
INCLUDED . . . . . X . . . . .
LAG GRN 0.0 YEL 0.0 RED 0.0
    
```

OVERLAP A

Select TMG VEH OVLP [A] and 'PPLT FYA'

```

TMG VEH OVLP...[A] TYPE: .....PPLT FYA
PROTECTED LEFT TURN.... PHASE 1
OPPOSING THROUGH..... PHASE 2

FLASHING ARROW OUTPUT.....CH9 ISOLATE
DELAY START OF: FYA..0.0 CLEARANCE..0.0
ACTION PLAN SF BIT DISABLE..... 0
    
```

OVERLAP B

Select TMG VEH OVLP [B] and 'PPLT FYA'

```

TMG VEH OVLP...[B] TYPE: .....PPLT FYA
PROTECTED LEFT TURN.... OVERLAP G
OPPOSING THROUGH..... PHASE 6

FLASHING ARROW OUTPUT.....CH10 ISOLATE
DELAY START OF: FYA..0.0 CLEARANCE..0.0
ACTION PLAN SF BIT DISABLE..... 0
    
```

OVERLAP C

Select TMG VEH OVLP [C] and 'PPLT FYA'

```

TMG VEH OVLP...[C] TYPE: .....PPLT FYA
PROTECTED LEFT TURN.... PHASE 5
OPPOSING THROUGH..... PHASE 6

FLASHING ARROW OUTPUT.....CH11 ISOLATE
DELAY START OF: FYA..0.0 CLEARANCE..0.0
ACTION PLAN SF BIT DISABLE..... 0
    
```

OVERLAP D

Select TMG VEH OVLP [D] and 'OTHER/ECONOLITE'

```

TMG VEH OVLP...[D] TYPE: OTHER/ECONOLITE
PHASES 1 2 3 4 5 6 7 8 9 0 1 2 3 4 5 6
INCLUDED . . . X . . . . .
PROTECT . . . . .
PED PRTC . . . . .
NOT OVLP . . . . .
FLSH GRN . . . 1 . . . . .
LAG X PH . . . . .
LAG 2 PH . . . . .

LAG GRN 0.0 YEL 0.0 RED 0.0 ADV GRN 0.0
    
```

OVERLAP E

Select TMG VEH OVLP [E] and 'NORMAL'

```

TMG VEH OVLP...[E] TYPE: .....NORMAL
PHASES 1 2 3 4 5 6 7 8 9 0 1 2 3 4 5 6
INCLUDED . . . . . X . . . . .

LAG GRN 0.0 YEL 0.0 RED 0.0
    
```

END PROGRAMMING

ECONOLITE ASC/3-2070 LOAD SWITCH ASSIGNMENT DETAIL

(program controller as shown)

To assign load switch S3 as OLG, program LD SWITCH 3 as OVLP '7' TYPE 'O' as shown below.

- From Main Menu select **1. CONFIGURATION**
- From CONFIGURATION Submenu select **3. LOAD SW ASSIGN**

LD SWITCH ASSIGN	PHASE /OVLP	TYPE	DIMMING			---FLASH---		
			R	Y	G	PWR	AUT	TGR
1	1	V	.	.	+	A	R	X
2	2	V	.	.	+	A	Y	.
3	7	O	.	.	+	A	R	.
4	4	V	.	.	+	A	R	X
5	5	V	.	.	-	A	R	.
6	6	V	.	.	-	A	Y	X
7	7	V	.	.	-	A	R	X
8	8	V	.	.	-	A	R	.
9	1	O	.	.	+	A	Y	X
10	2	O	.	.	+	A	Y	X
11	3	O	.	.	-	A	Y	.
12	4	O	.	.	-	A	R	.
13	2	P	.	.	+	A	.	.
14	4	P	.	.	-	A	.	.
15	6	P	.	.	+	A	.	.
16	8	P	.	.	-	A	.	.

THIS ELECTRICAL DETAIL SUPERSEDES THE DETAIL SEALED ON 12/17/2019

THIS ELECTRICAL DETAIL IS FOR THE SIGNAL DESIGN: 07-2060
 DESIGNED: September 2020
 SEALED: 12/15/2020
 REVISED: N/A

LOAD RESISTOR INSTALLATION DETAIL

(install resistors as shown below)

ACCEPTABLE VALUES	
VALUE (ohms)	WATTAGE
1.5K - 1.9K	25W (min)
2.0K - 3.0K	10W (min)

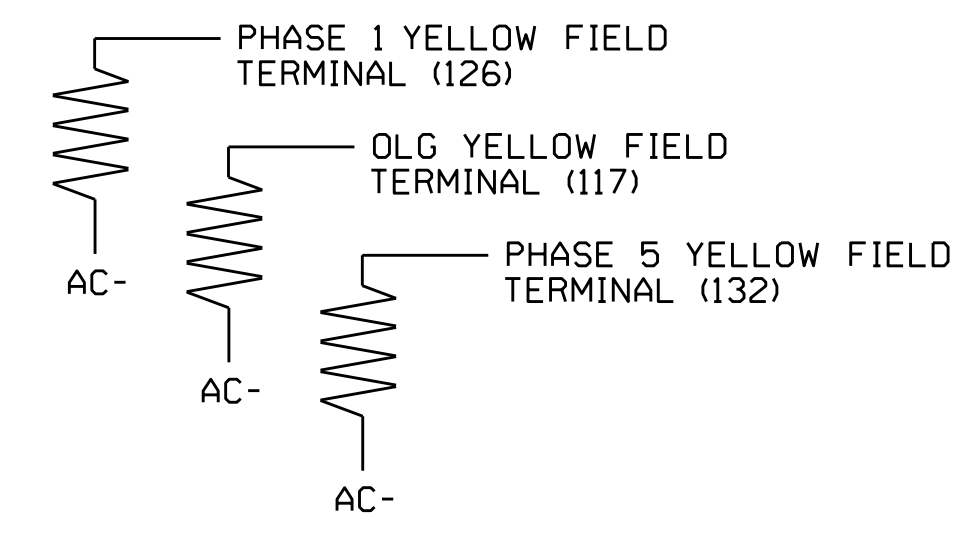

COUNTDOWN PEDESTRIAN SIGNAL OPERATION

Countdown Ped Signals are required to display timing only during Ped Clearance Interval. Consult Ped Signal Module user's manual for instructions on selecting this feature.

Electrical Detail - Sheet 2 of 3

ELECTRICAL AND PROGRAMMING DETAILS FOR: Prepared In the Offices of: 750 N. Greenfield Pkwy, Garner, NC 27529	SR 1007 (Mebane Oaks Rd.) at Garrett Crossing and Wilson Rd. Connector	DOCUMENT NOT CONSIDERED FINAL UNLESS ALL SIGNATURES COMPLETED SEAL Ryan W. Hough 12/15/2020
	Division 7 Alamance County Mebane PLAN DATE: November 2020 REVIEWED BY: PREPARED BY: S. Armstrong REVIEWED BY: REVISIONS INIT. DATE SIGNATURE NO. 07-2060	

15-1066-2020 13:23
 4012060.dwg ete-wrk.dwg
 sarmstrong