

EDI MODEL 2018ECL-NC CONFLICT MONITOR PROGRAMMING DETAIL

(remove jumpers and set switches as shown)

REMOVE DIODE JUMPERS 1-5, 1-6, 1-9, 1-10, 1-11, 1-15, 2-5, 2-6, 2-9, 2-10, 2-11, 2-13, 2-15, 3-4, 3-10, 3-12, 3-14, 3-17, 4-8, 4-10, 4-12, 4-14, 4-16, 4-17, 5-9, 5-11, 5-13, 6-9, 6-10, 6-11, 6-13, 6-15, 8-12, 8-14, 8-16, 9-10, 9-11, 9-13, 9-15, 10-11, 10-12, 10-13, 10-14, 10-15, 10-17, 11-13, 11-15, 12-14, 12-16, 12-17, 13-15, 14-16, AND 14-17.

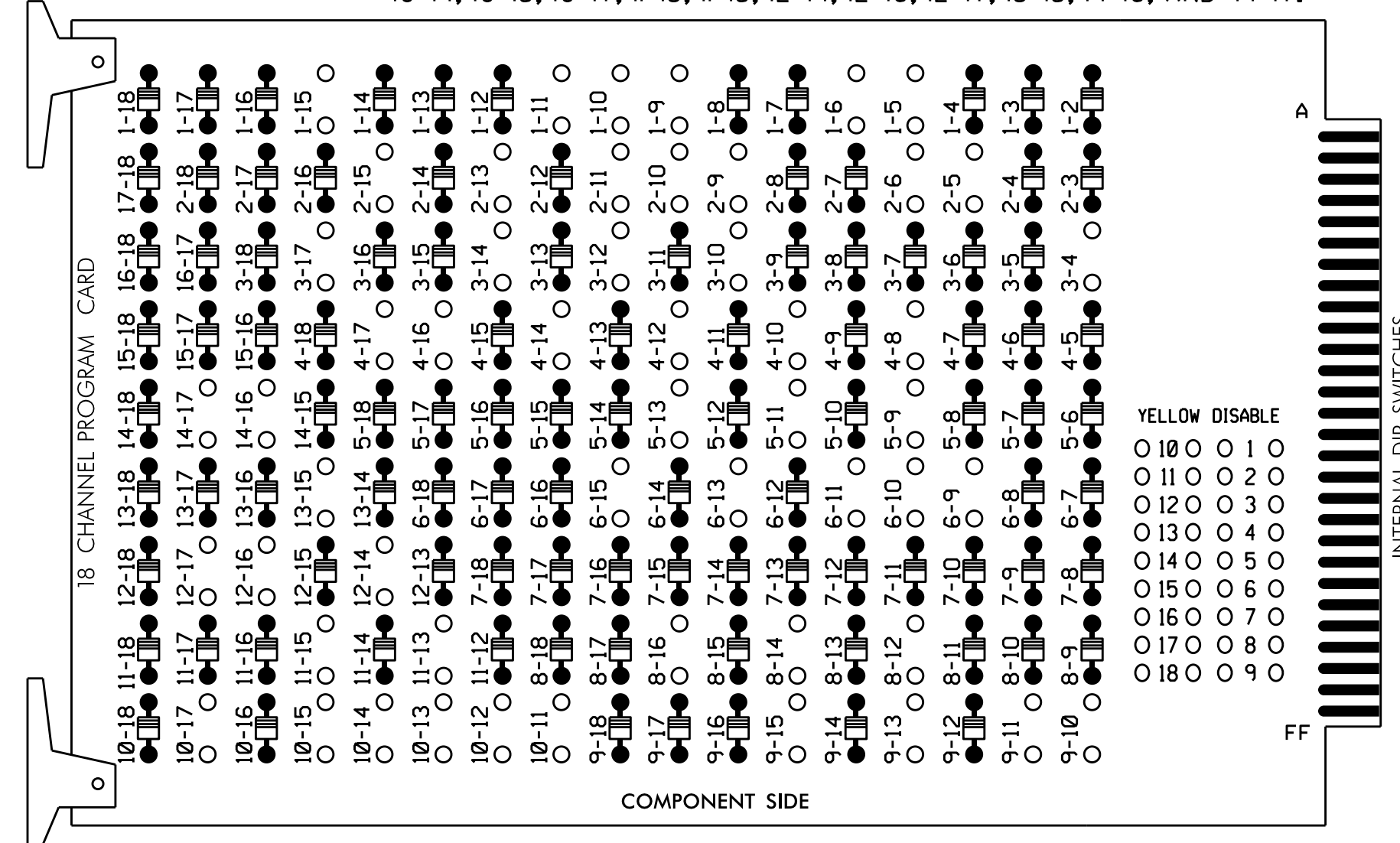

REMOVE JUMPERS AS SHOWN

NOTES:

- Card is provided with all diode jumpers in place. Removal of any jumper allows its channels to run concurrently.
- Ensure jumpers SEL2-SEL5 and SEL9 are present on the monitor board.
- Ensure that Red Enable is active at all times during normal operation.
- Connect serial cable from conflict monitor to comm. port 1 of 2070 controller. Ensure conflict monitor communicates with 2070.

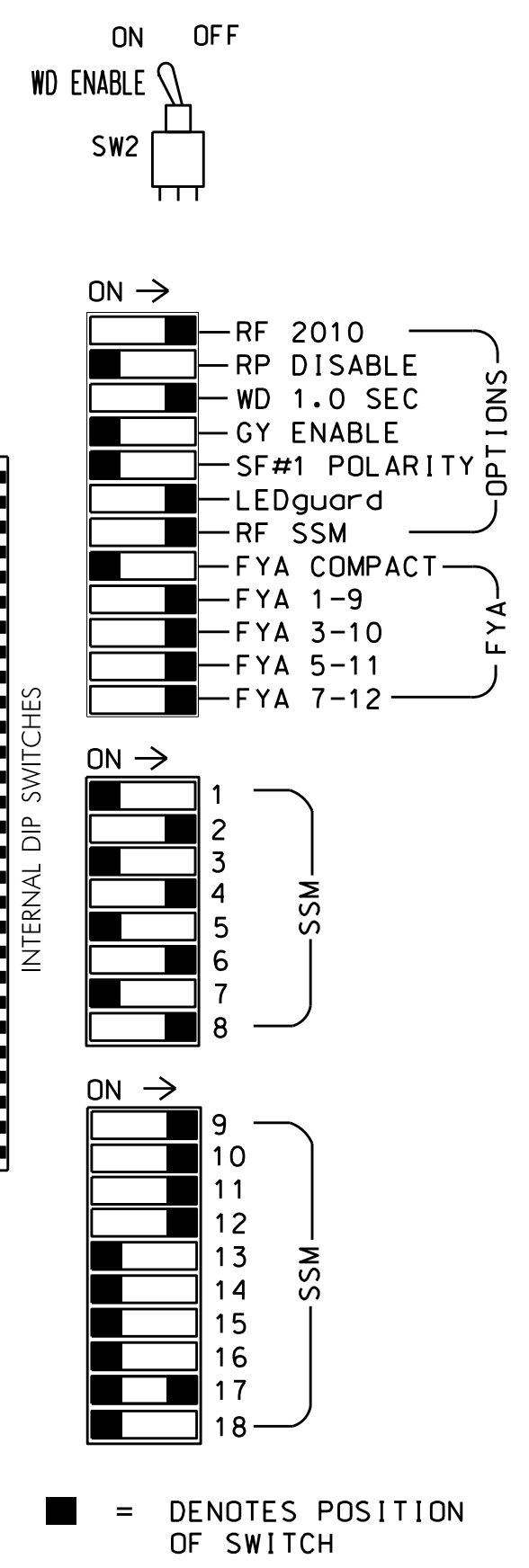

NOTES

- To prevent "flash-conflict" problems, insert red flash program blocks for all unused vehicle load switches in the output file. The installer shall verify that signal heads flash in accordance with the Signal Plans.
- Program phase 4 for Dual Entry.
- Program controller to start up in phase 2 Walk and phase 6 Walk.
- If this signal will be managed by an ATMS software, enable controller and detector logging for all enabled detectors.
- The cabinet and controller are part of the SR 1007 (Mebane Oaks Rd) CLS, Signal System: 10705.

EQUIPMENT INFORMATION

CONTROLLER.....2070
 CABINET.....332 W/ AUX
 SOFTWARE.....ECONOLITE ASC/3-2070
 CABINET MOUNT.....BASE
 OUTPUT FILE POSITIONS...18 WITH AUX. OUTPUT FILE
 LOAD SWITCHES USED.....S1,S2,S3,S4,S5,S6,S7,S8,S9,S11,S12
 AUX S1,AUX S2,AUX S3,AUX S4,AUX S5
 PHASES USED.....1,2,2PED,4,4PED,5,6,6PED,7*,8,8PED
 OVERLAP "A".....**
 OVERLAP "B".....**
 OVERLAP "C".....**
 OVERLAP "D".....**
 OVERLAP "E".....**
 OVERLAP "G".....**

* Phase used for timing purposes only
 ** See overlap programming detail on sheet 2

SIGNAL HEAD HOOK-UP CHART

LOAD SWITCH NO.	S1	S2	S3	S4	S5	S6	S7	S8	S9	S10	S11	S12	AUX S1	AUX S2	AUX S3	AUX S4	AUX S5	AUX S6
CMU CHANNEL NO.	1	2	13	3	4	14	5	6	15	7	8	16	9	10	17	11	12	18
PHASE	1	2	2 PED	OLG	4	4 PED	5	6	6 PED	7	8	8 PED	OLA	OLB	OLE	OLC	OLD	SPARE
SIGNAL HEAD NO.	11	21,22	P21, P22	63	41,42	P41, P42	51	61,62	P61, P62	NC	82,83	P82, P83	11	63	71,72	51	81	NU
RED		128			101			134			107			A124			A101	
YELLOW	*	129		*	102		*	135			108							
GREEN		130			103			136			109							
RED ARROW														A121	A111	A114		
YELLOW ARROW														A122	A125	A112	A115	A102
FLASHING YELLOW ARROW														A123	A126		A116	A103
GREEN ARROW	127				118			133									A113	
Hand				113			104		119			110						
Person				115			106		121			112						

NU = Not Used
 NC = Not Connected
 * Denotes install load resistor. See load resistor installation detail on sheet 2.
 * See pictorial of head wiring in detail this sheet.

INPUT FILE POSITION LAYOUT

(front view)

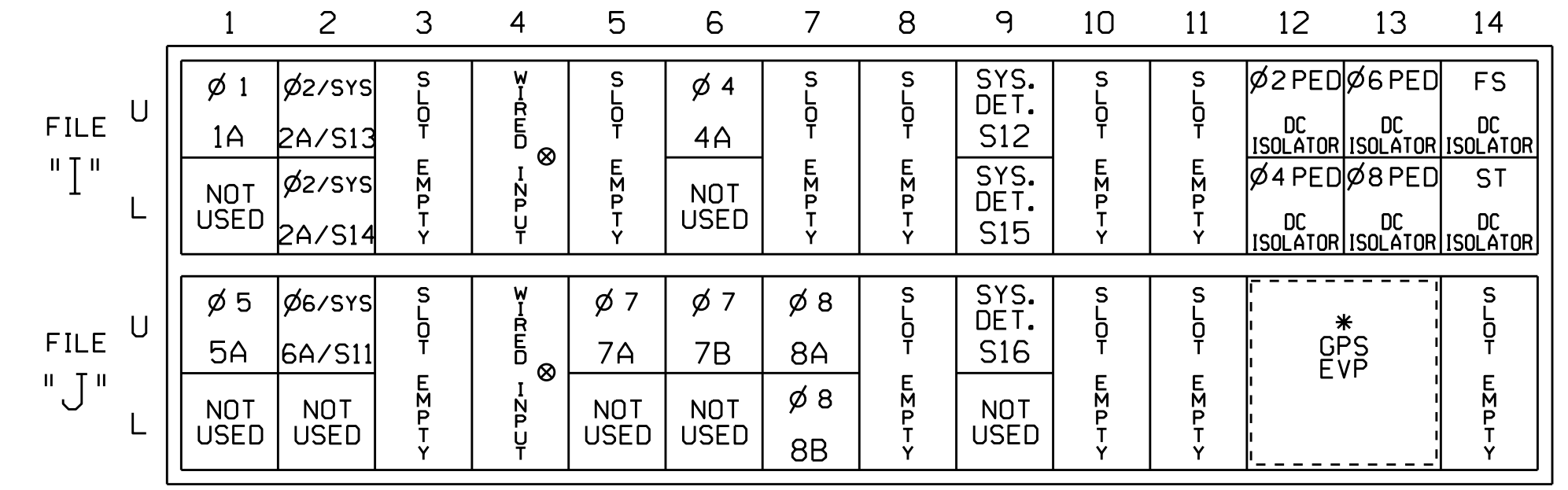

EX.: 1A, 2A, ETC. = LOOP NO.'S
 FS = FLASH SENSE
 ST = STOP TIME
 * Wired Input - Do not populate slot with detector card

INPUT FILE CONNECTION & PROGRAMMING CHART

LOOP NO.	LOOP TERMINAL	INPUT FILE POS.	PIN NO.	DETECTOR NO.	NEMA PHASE	CALL	EXTEND TIME	DELAY TIME	ADDED INITIAL	DETECTOR TYPE
1A	TB2-1,2	I1U	56	1	1	YES		15		S
	-	J4U	48	26	6	YES		3		G
2A/S13	TB2-5,6	I2U	39	2	2/SYS	YES			X	N
2B/S14	TB2-7,8	I2L	43	12	2/SYS	YES			X	N
4A	TB4-9,10	I6U	41	4	4	YES		10		S
	-	J1U	55	5	5	YES		15		S
5A	TB3-1,2	I1U	55	5	5	YES		15		S
	-	I4U	47	22	2	YES		3		G
6A/S11	TB3-5,6	J2U	40	6	6/SYS	YES			X	N
7A	TB5-5,6	J5U	57	7	7	YES		3		S
7B	TB5-9,10	J6U	42	8	7	YES				S
8A	TB7-1,2	J7U	66	38	8	YES		3		S
8B	TB7-3,4	J7L	79	48	8	YES		10		S
* S12	TB6-9,10	I9U	60	11	SYS	NO				N
* S15	TB6-11,12	I9L	62	13	SYS	NO				N
* S16	TB7-9,10	J9U	59	15	SYS	NO				N
PED PUSH BUTTONS										
P21,P22	TB8-4,6	I12U	67	PED 2	2 PED					
P41,P42	TB8-5,6	I12L	69	PED 4	4 PED					
P61,P62	TB8-7,9	I13U	68	PED 6	6 PED					
P81,P82	TB8-8,9	I13L	70	PED 8	8 PED					

NOTE:
 INSTALL DC ISOLATORS IN INPUT FILE SLOTS 112 AND 113.

- * Add jumper from I1-W to J4-W, on rear of input file.
- * Add jumper from J1-W to I4-W, on rear of input file.
- * System detector only. Remove any assigned vehicle phase.

INPUT FILE POSITION LEGEND: J2L

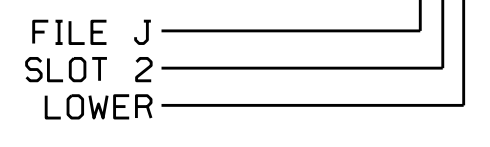

FYA SIGNAL WIRING DETAIL

(wire signal heads as shown)

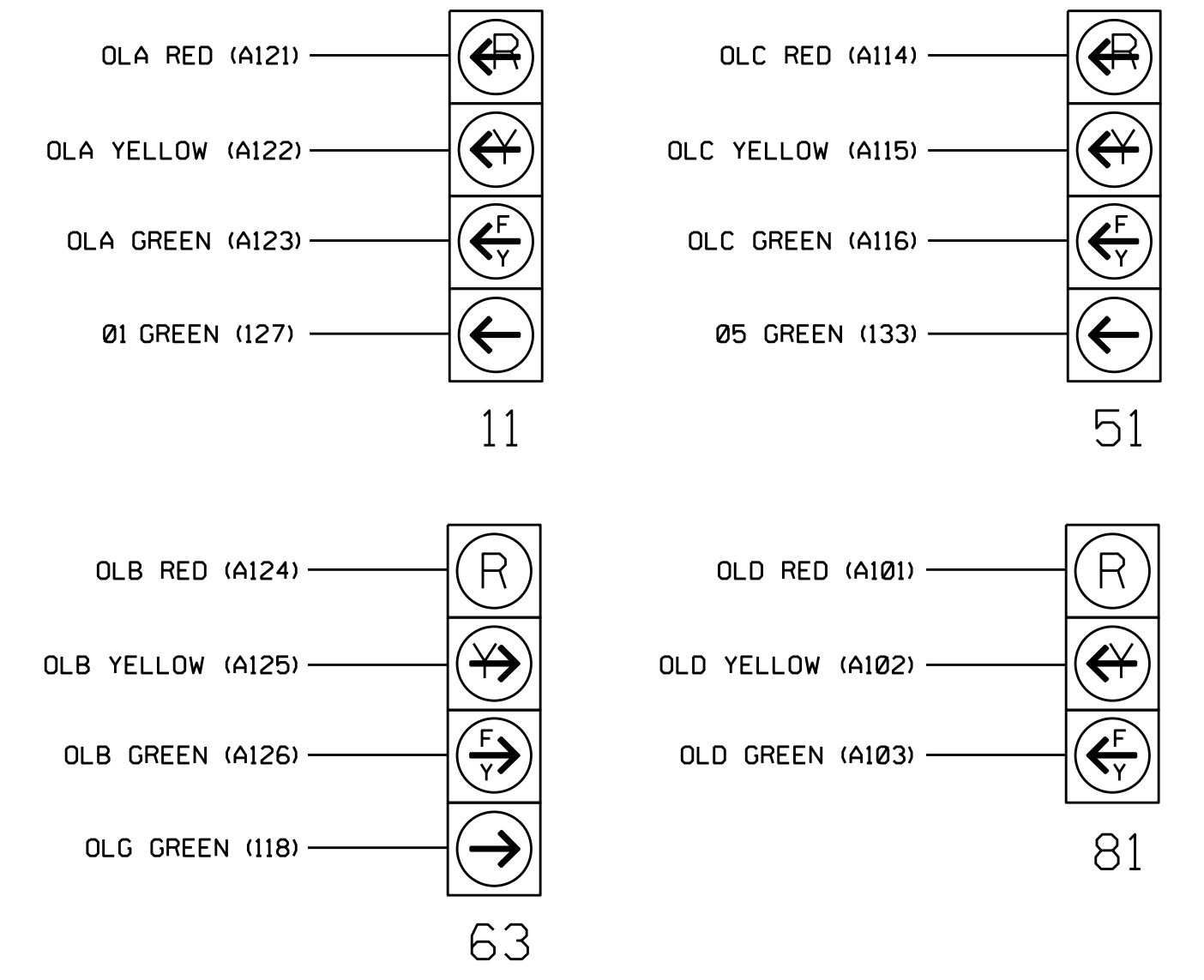

SPECIAL DETECTOR NOTE
 Install a GPS preemption system. Perform installation according to manufacturer's directions and NCDOT engineer approved mounting location to accomplish the preemption schemes shown on the Signal Design Plans.

THIS ELECTRICAL DETAIL IS FOR THE SIGNAL DESIGN: 07-2060
 DESIGNED: September 2020
 SEALED: 12/15/2020
 REVISED: N/A

THIS ELECTRICAL DETAIL SUPERSEDES THE DETAIL SEALED ON 12/17/2019

Electrical Detail - Sheet 1 of 3

Prepared In the Offices of:
 G. J. TRANSPORTATION MOBILITY AND SAFETY DIVISION
 NORTH CAROLINA DEPARTMENT OF TRANSPORTATION
 SIGNALS MANAGEMENT SECTION
 750 N. Greenfield Pkwy, Garner, NC 27529

SR 1007 (Mebane Oaks Rd.) at Garrett Crossing and Wilson Rd. Connector

Division 7 Alamance County Mebane

PLAN DATE: November 2020 REVIEWED BY:
 PREPARED BY: S. Armstrong REVIEWED BY:

REVISIONS INIT. DATE

SEAL
 NORTH CAROLINA PROFESSIONAL ENGINEER
 RYAN W. HOUGH
 036833
 12/15/2020
 SIGNATURE DATE

SIG. INVENTORY NO. 07-2060

15-DEC-2020 13:22
 S:\IT\SSM\15-Signal\work\hgr\oups\51g_MonMtrmsfrmg072060_sml.ele.xxx.dgn
 sarmstrong