

5/14/99

PROJECT TYPICAL DETAILS

PROJECT REFERENCE NO. B-5671	SHEET NO. UC-3B
DESIGNED BY: DK	
DRAWN BY: AP	
CHECKED BY: MM	
APPROVED BY:	
REVISED:	
NORTH CAROLINA DEPARTMENT OF TRANSPORTATION UTILITIES ENGINEERING SEC. PHONE: (919) 707-6690 FAX: (919) 250-4151	
UTILITY CONSTRUCTION PLANS ONLY	
Engineers • Planners • Scientists • Construction Managers 4505 Falls of Neuse Road, Suite 400 Raleigh, NC 27609 Phone (919) 783-9214 • Fax (919) 783-9266 License No. C-764	

UTILITY CONSTRUCTION

**DOCUMENT NOT CONSIDERED FINAL
UNLESS ALL SIGNATURES COMPLETED**

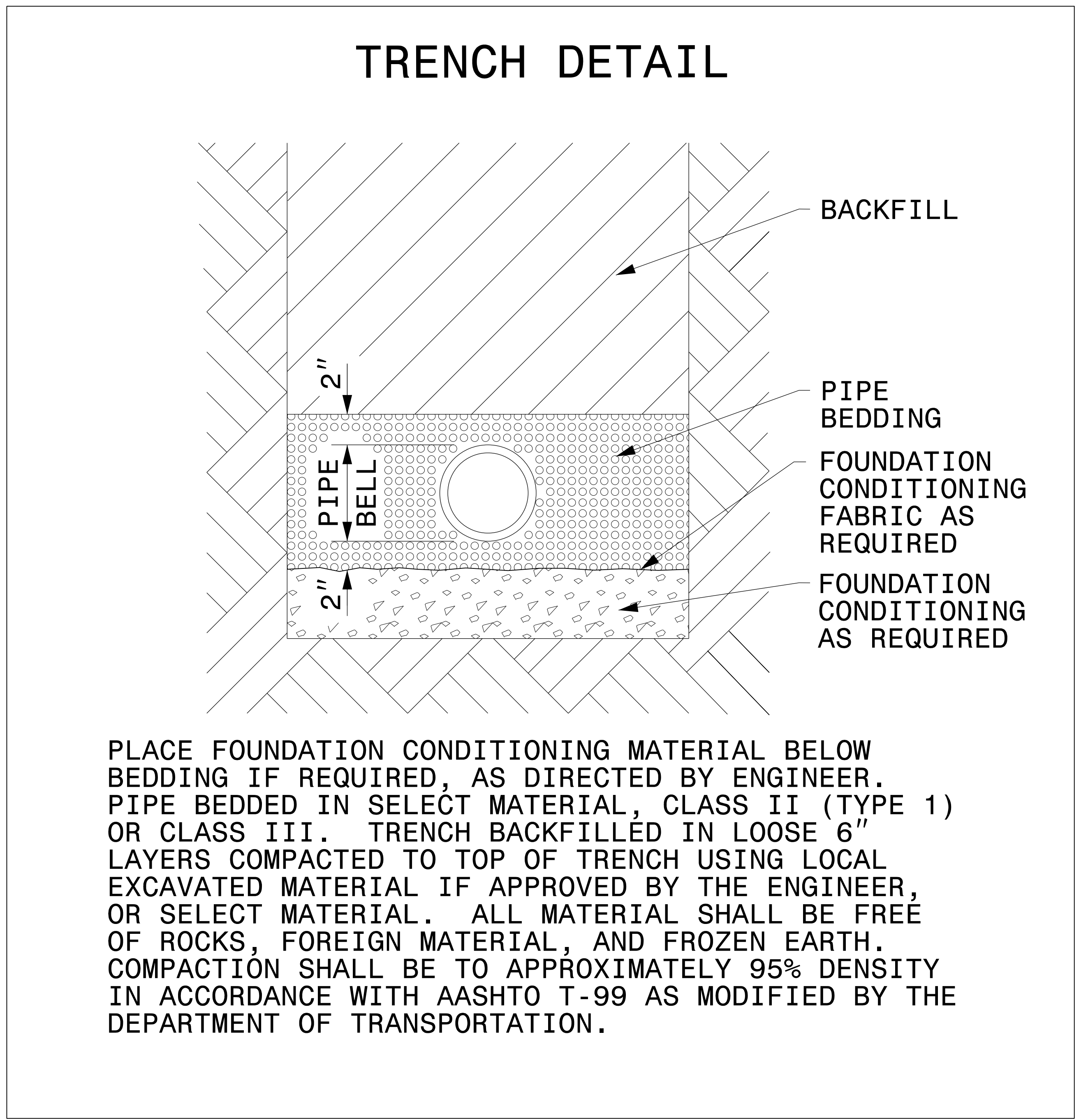
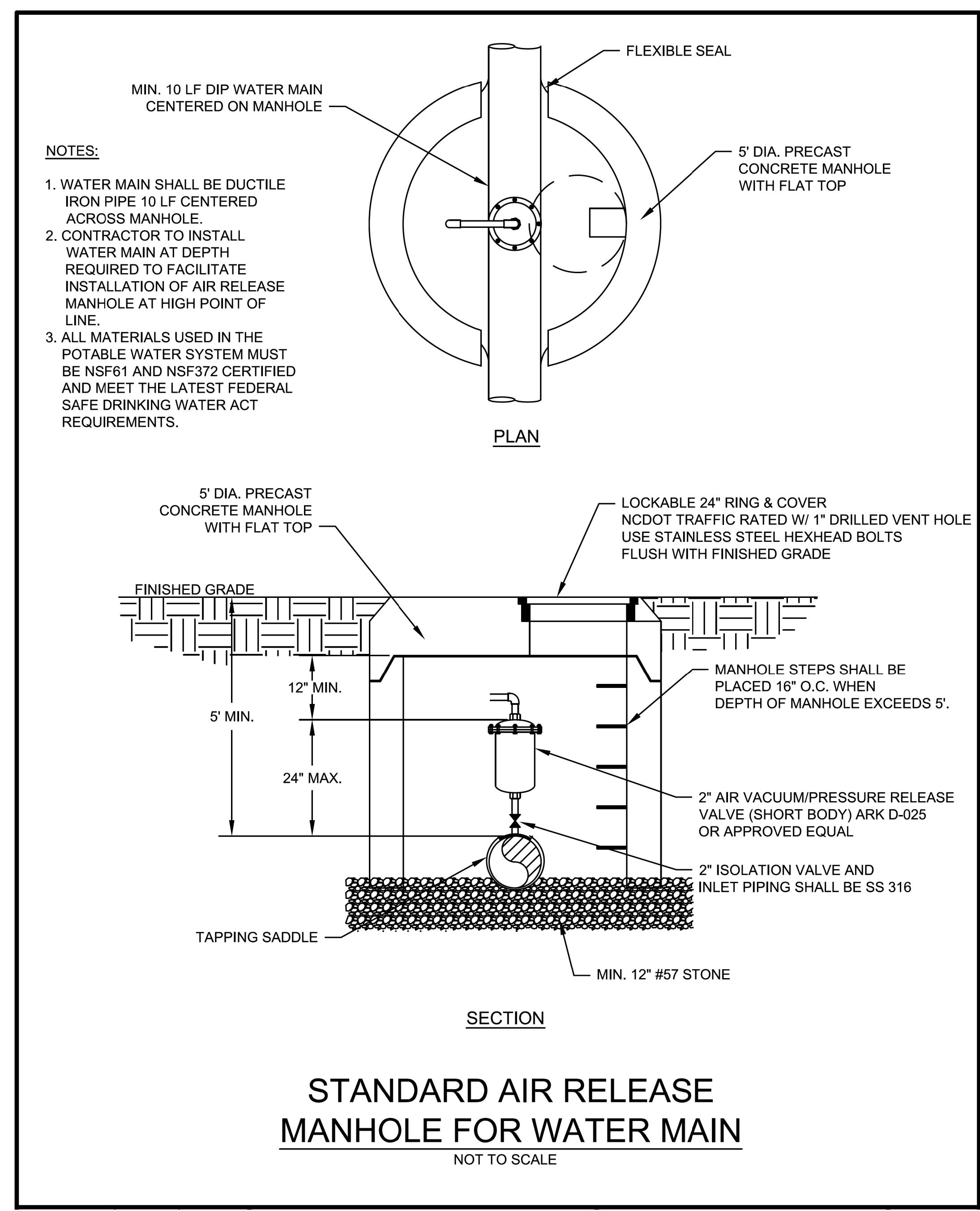

26 MAR 2020 11:57 AM
C:\Users\jfernanz\OneDrive\Documents\Projects\Water\B5671.dwg