

4/7/2020 4:10:48 PM G:\Projects\2018\Division 3 (SEA)\B-5639 (Duplin 36 NC11 over MaxwellCreek)\Structures\Drawings\Final\B5639_SMU_SUPER_300036.dgn

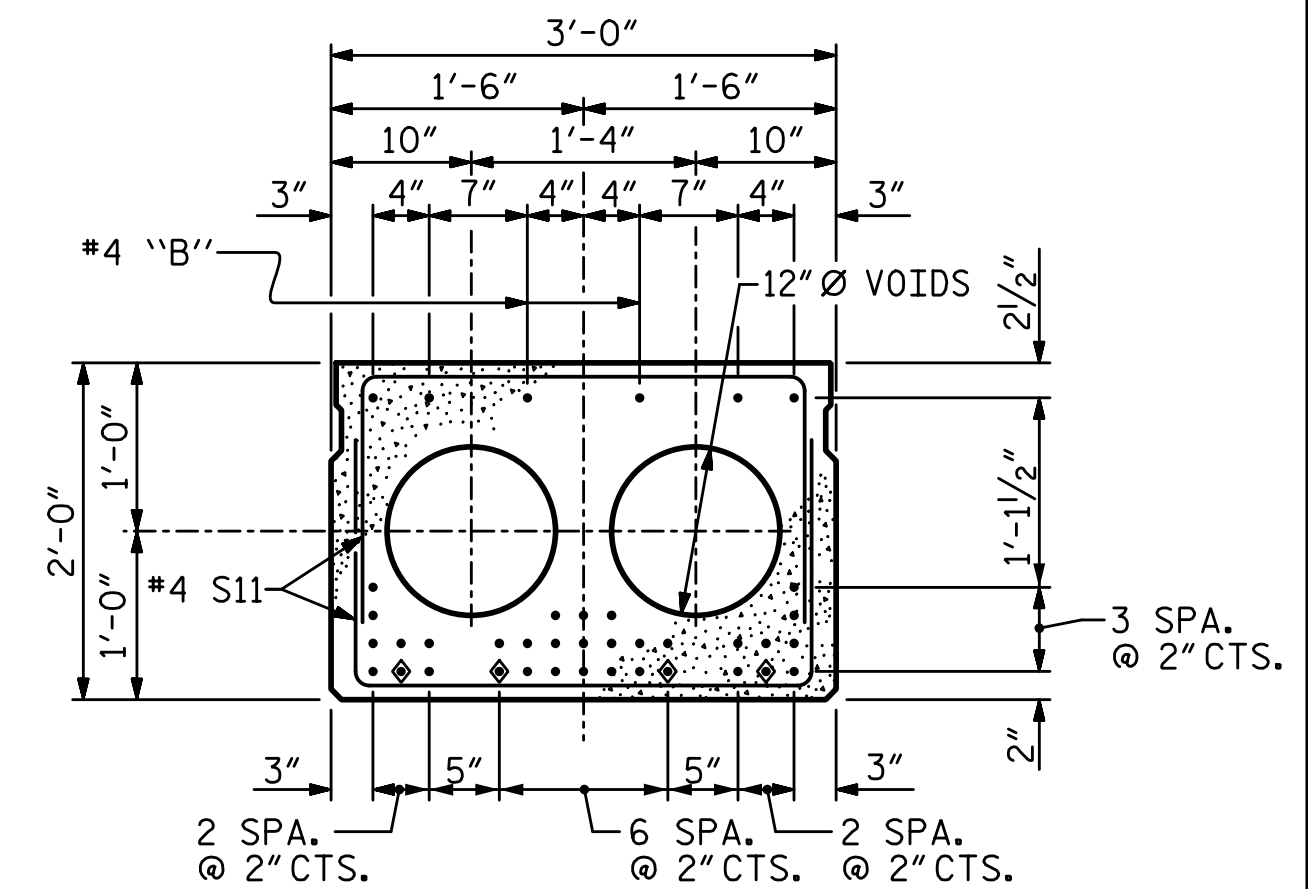
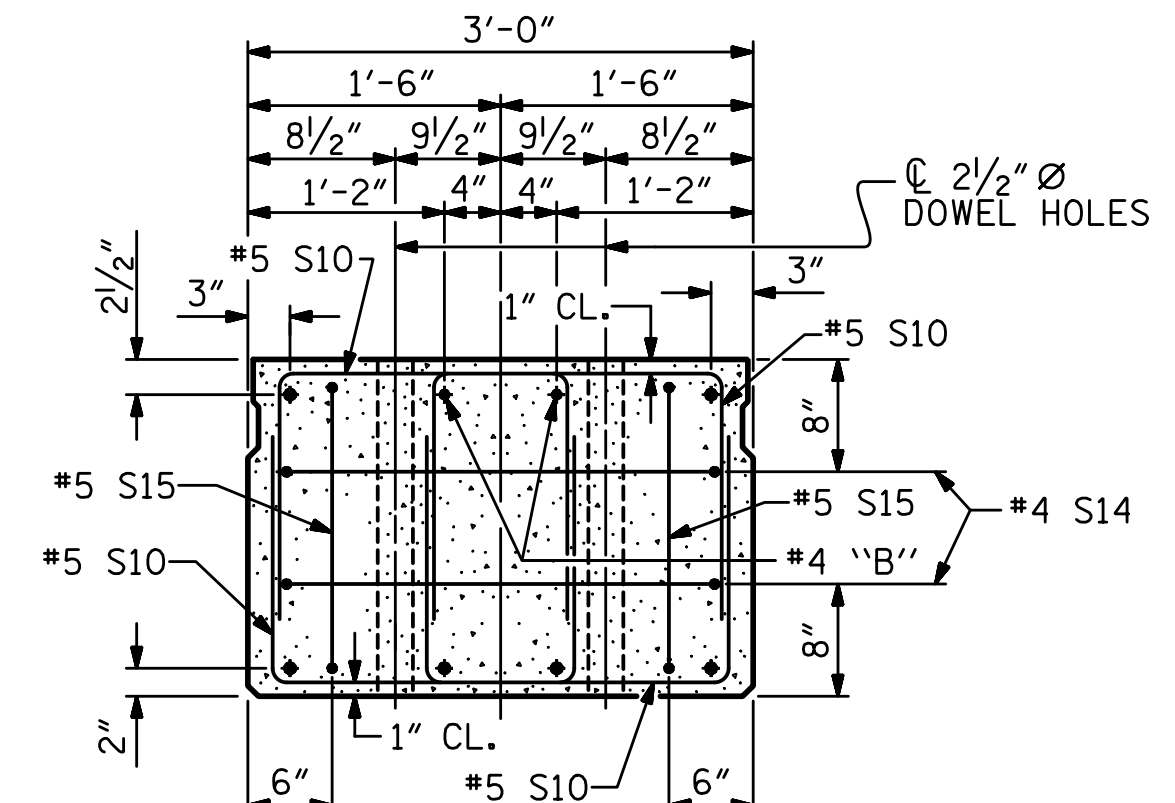
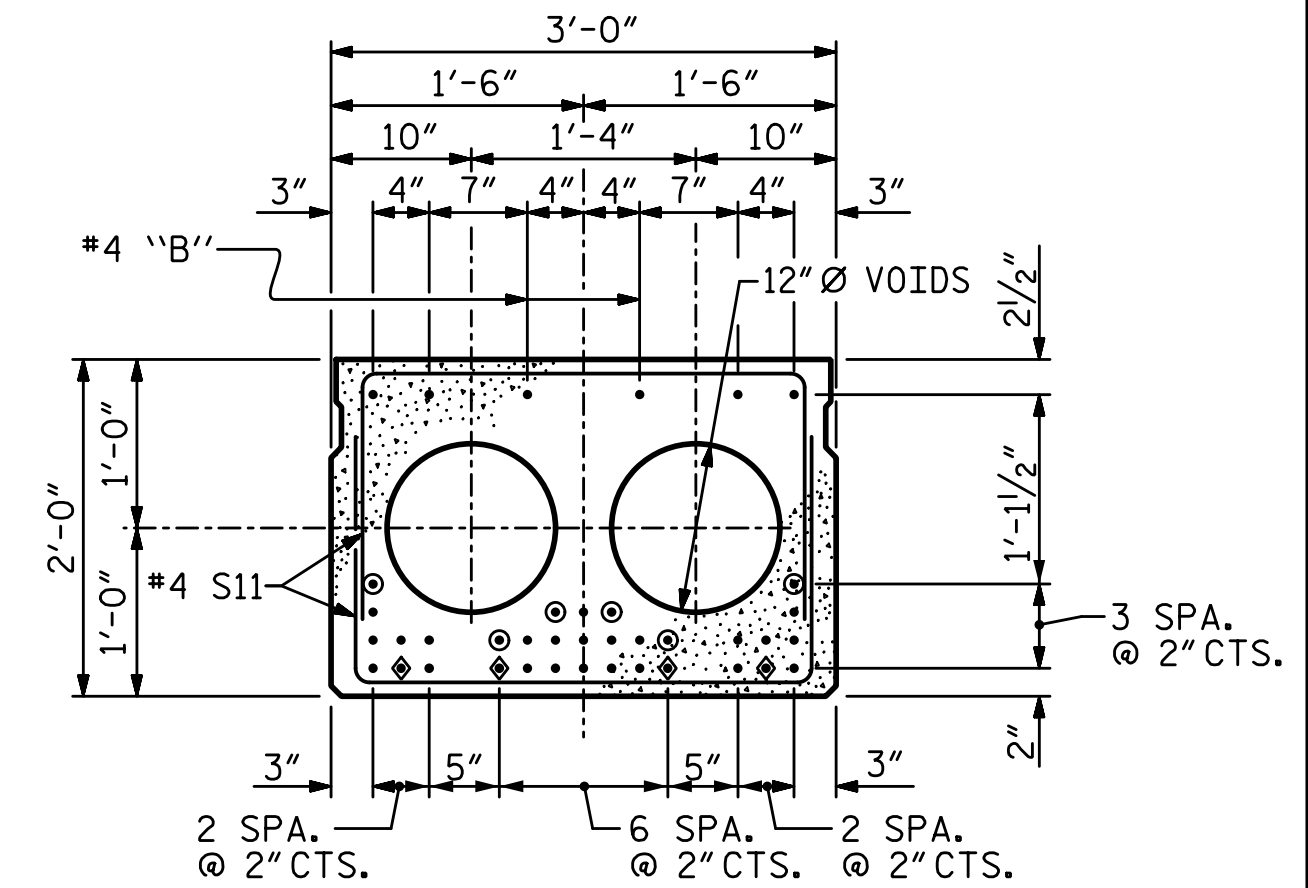
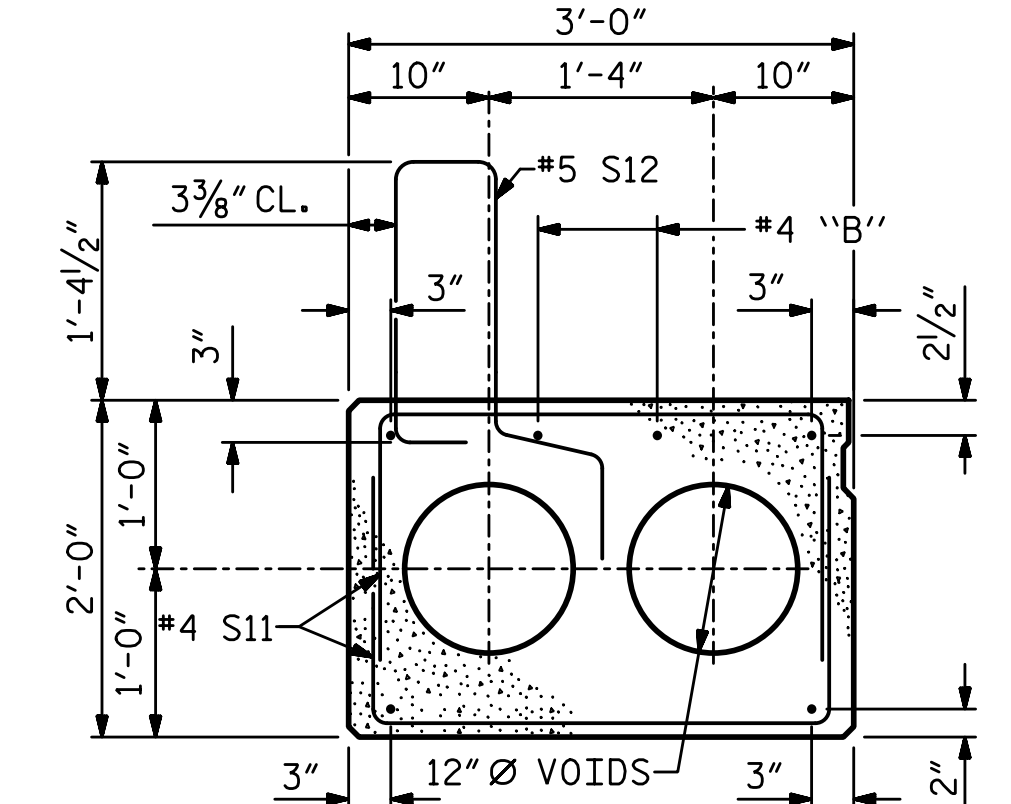
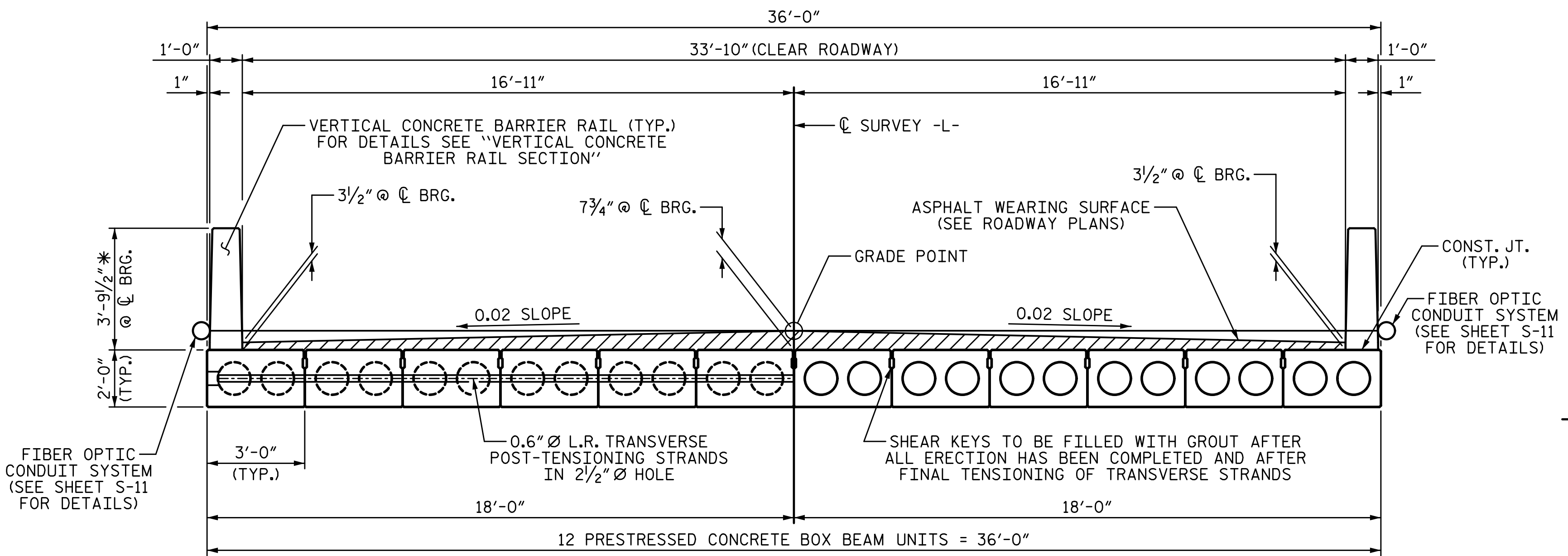

HALF SECTION
(AT INTERMEDIATE DIAPHRAGMS)

HALF SECTION
(THROUGH VOIDS)

TYPICAL SECTION

* - THE MAXIMUM BARRIER RAIL HEIGHT AND ASPHALT THICKNESS IS SHOWN. THE HEIGHT OF THE BARRIER RAIL AND ASPHALT THICKNESS VARIES WHILE THE TOP OF THE BARRIER RAIL FOLLOWS THE PROFILE OF THE GUTTERLINE. FOR RAIL HEIGHT DETAILS AND ASPHALT THICKNESS, SEE THE "VERTICAL CONCRETE BARRIER RAIL SECTION" DETAIL.

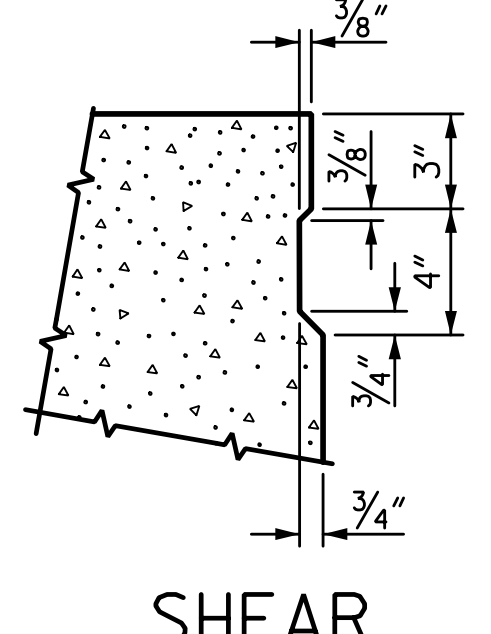
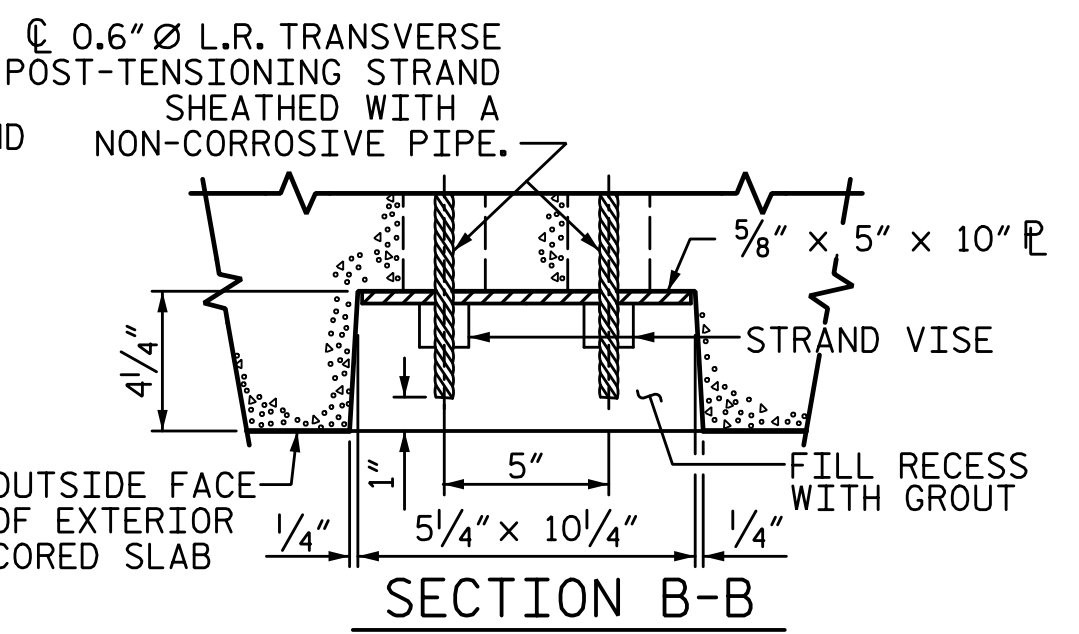
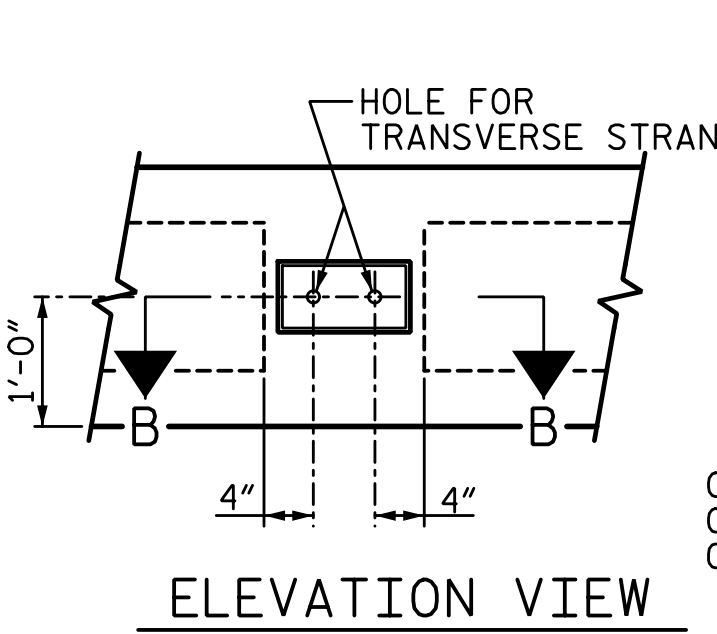

GROUTED RECESS AT END OF POST-TENSIONED STRAND FOR CORED SLABS

NOTE: OMIT SHEAR KEY ON OUTSIDE FACE OF EXTERIOR CORED SLABS.

FIXED END

FIXED END

FIXED END

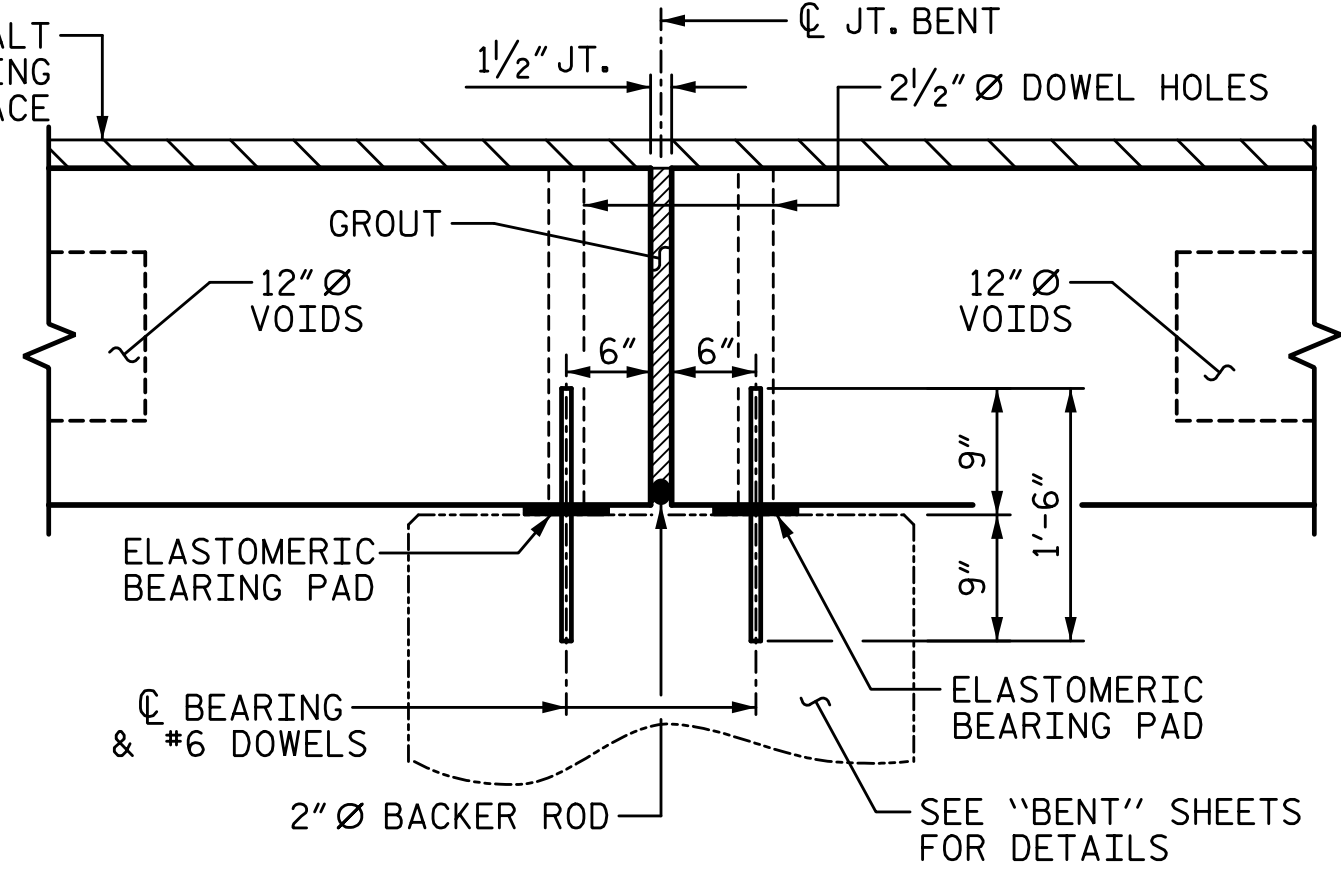
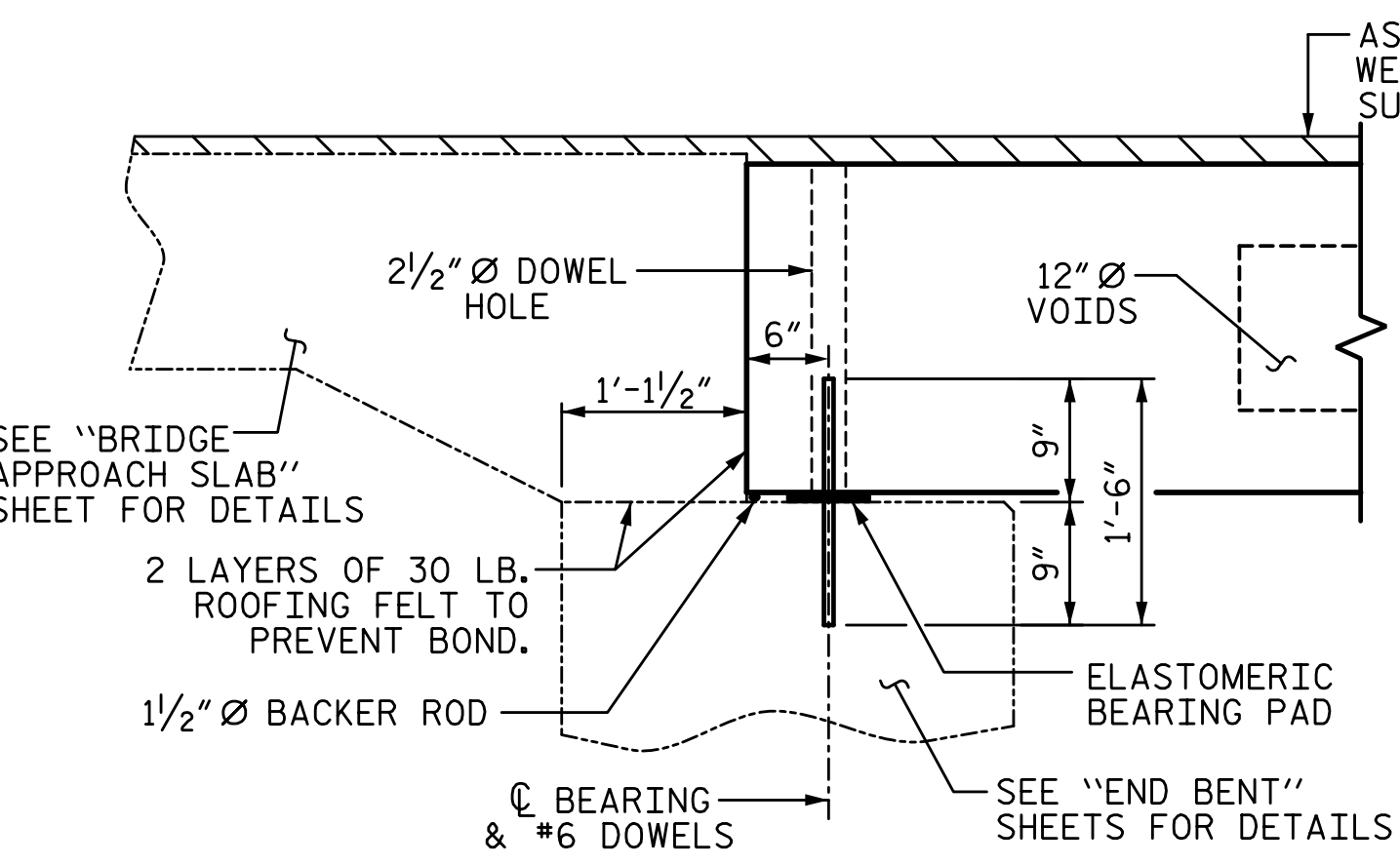

PERMITTED THREADED INSERT CAST IN OUTSIDE FACE OF EXTERIOR UNIT AND RECESSED 3/8" SIZE TO BE DETERMINED BY CONTRACTOR.

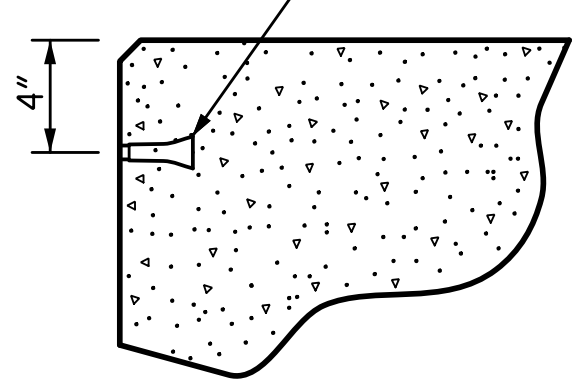

0.6" Ø LOW RELAXATION STRAND LAYOUT

- ◆ BOND SHALL BE BROKEN ON THESE STRANDS FOR A DISTANCE OF 12'-0" FROM END OF CORED SLAB UNIT. SEE STANDARD SPECIFICATIONS, ARTICLE 1078-7.
- OPTIONAL FULL LENGTH DEBONDED STRANDS. THESE STRANDS ARE NOT REQUIRED. IF THE FABRICATOR CHOOSES TO INCLUDE THESE STRANDS IN THE CORED SLAB UNIT, THE STRANDS SHALL BE DEBONDED FOR THE FULL LENGTH OF THE UNIT AT NO ADDITIONAL COST. SEE STANDARD SPECIFICATIONS, ARTICLE 1078-7.

DEBONDING LEGEND

PROJECT NO. B-5639
 DUPLIN COUNTY
 STATION: 23+55.00 -L-

SHEET 1 OF 5

STATE OF NORTH CAROLINA
 DEPARTMENT OF TRANSPORTATION
 RALEIGH
 SUPERSTRUCTURE
 3'-0" X 2'-0"
 PRESTRESSED CONCRETE
 CORED SLAB UNIT
 90° SKEW

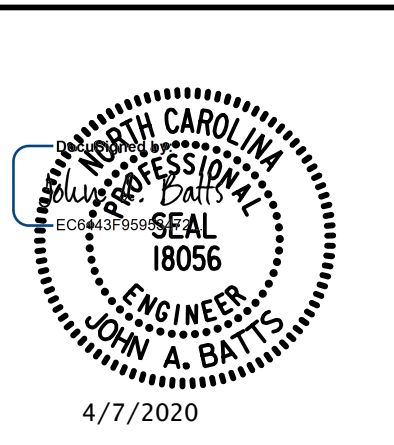

PLANS PREPARED BY:
SE & A
 SIMPSON ENGINEERS ASSOCIATES
 5640 Dillard Drive
 Suite 200
 Cary, NC 27518
 (919) 852-0468
 (919) 852-0538 (Fax)
 www.simpsonengr.com
 LICENSURE NO. C-2521

DRAWN BY: T. BANKOVICH	DATE: 2-20
CHECKED BY: J.A. BATTS	DATE: 2-20
DESIGN ENGINEER OF RECORD: J.A. BATTS	DATE: 2-20

DOCUMENT NOT CONSIDERED FINAL UNLESS ALL SIGNATURES COMPLETED				SHEET NO. S-7	
REVISIONS		NO.		DATE	
1	BY:	DATE:	3	BY:	DATE:
2			4		
				TOTAL SHEETS 25	