

6/2/2019

PROJECT REFERENCE NO. B-5639	SHEET NO. 2A-2
ROADWAY DESIGN ENGINEER SEAL MICHAEL TEKASEK 1/6/2018	PAVEMENT DESIGN ENGINEER SEAL MICHAEL S. MORRISON 1/7/2018
MOTT MACDONALD I & E, LLC LICENSE NO. F-0669	
<b>DOCUMENT NOT CONSIDERED FINAL UNLESS ALL SIGNATURES COMPLETED</b>	
Prepared in the Office of:	<b>M</b> MOTT MACDONALD PO Box 700 Fuquay-Varina, NC 27526 www.mottmcc.com/americas

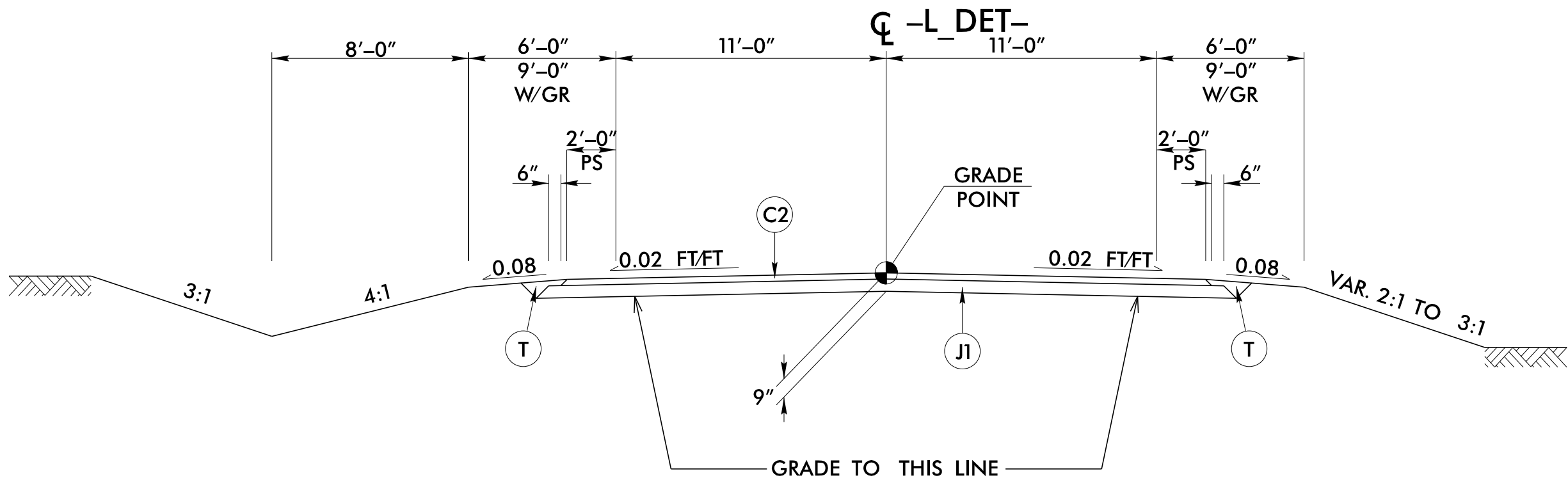

TYPICAL SECTION NO. 4

USE TYPICAL SECTION NO. 4

-L\_DET- STA. 13+71.67 TO 17+91.04 +/- (BEGIN BRIDGE)  
-L\_DET- STA. 19+61.04 +/- (END BRIDGE) TO 23+97.33

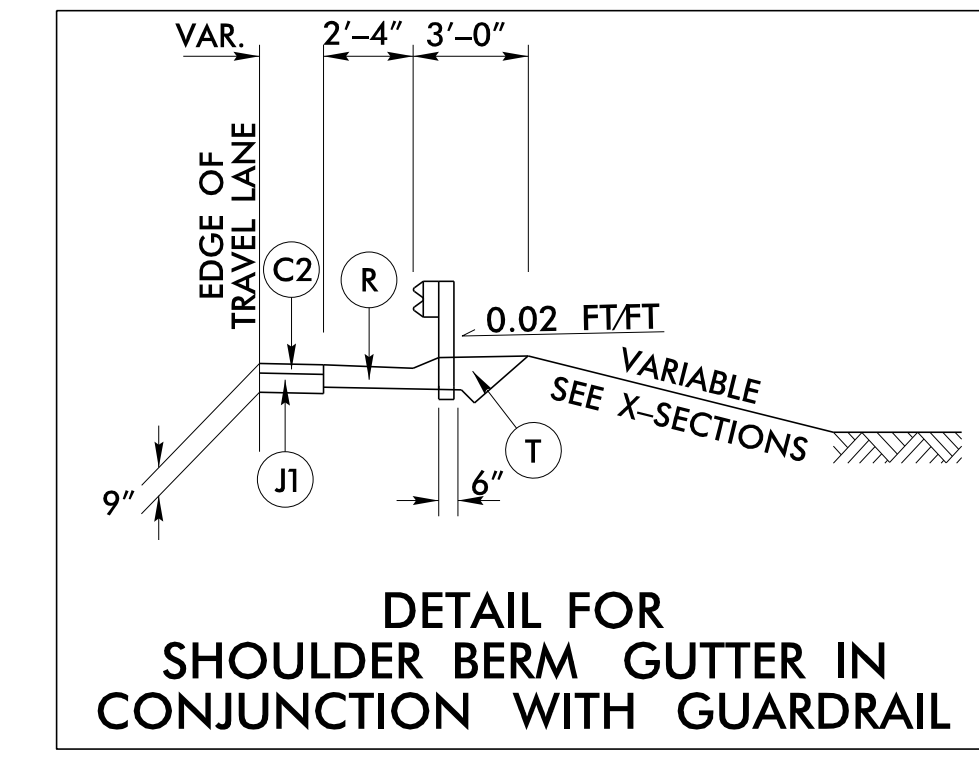

-L\_DET- STA 19+61.04 +/- TO 19+94.44 LT

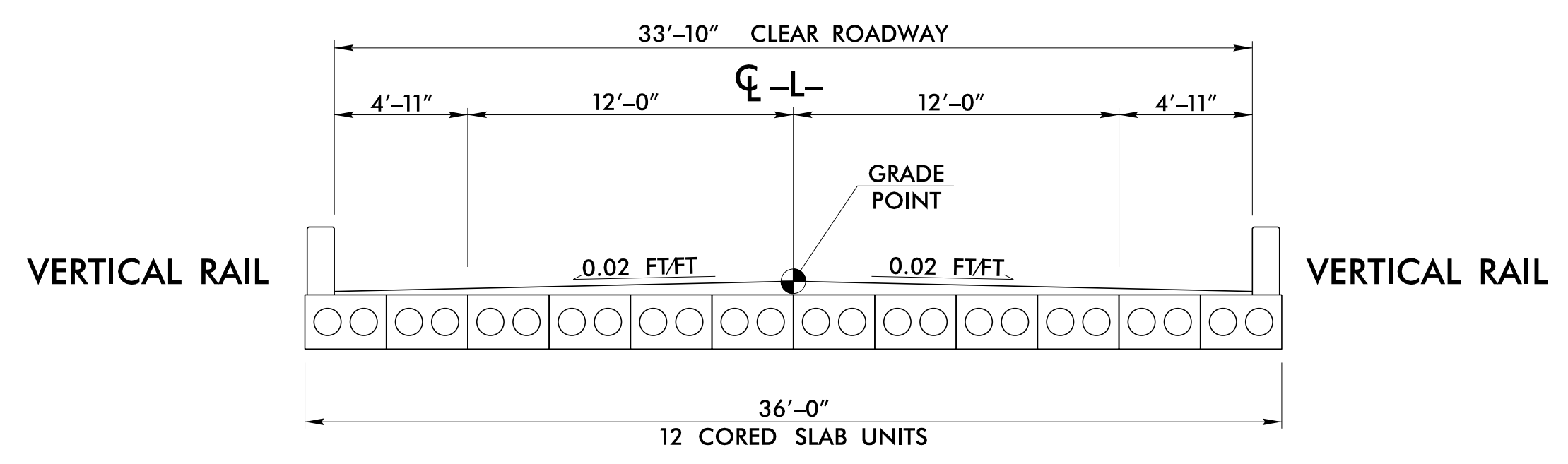

TYPICAL SECTION NO. 5

USE TYPICAL SECTION NO. 5:

-L- STA 22+68.75 (BEGIN BRIDGE) TO 24+41.25 (END BRIDGE)

NOTE: SEE STRUCTURE PLANS FOR AWS THICKNESS.

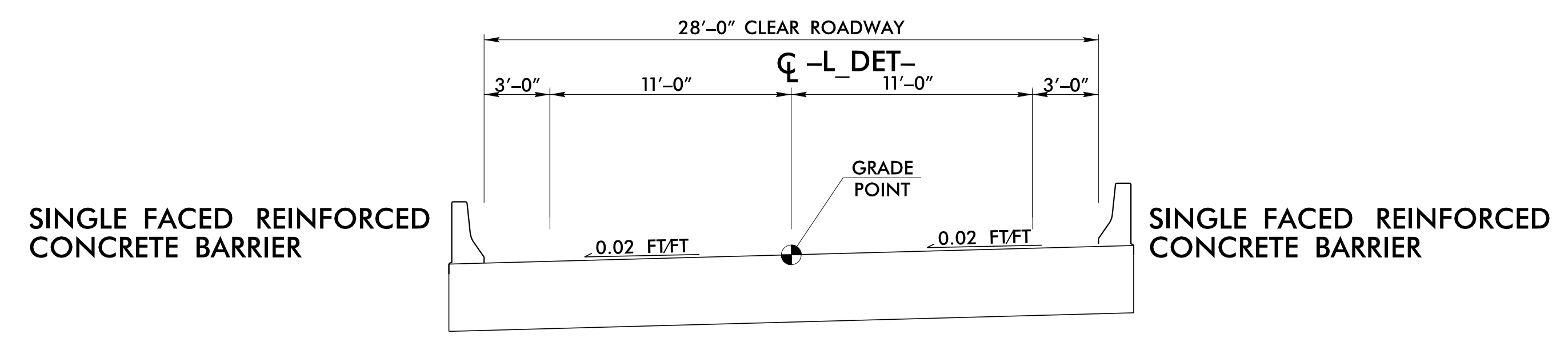

TYPICAL SECTION NO. 6

USE TYPICAL SECTION NO. 6

-L\_DET- STA. 17+91.04 +/- (BEGIN BRIDGE) TO 19+61.04 +/- (END BRIDGE)

FINAL PAVEMENT SCHEDULE	
C1	PROP. APPROX. 1½" ASPHALT CONCRETE SURFACE COURSE, TYPE S9.5B, AT AN AVERAGE RATE OF 165 LBS. PER SQ. YD.
C2	PROP. APPROX. 3" ASPHALT CONCRETE SURFACE COURSE, TYPE S9.5B, AT AN AVERAGE RATE OF 165 LBS. PER SQ. YD. IN EACH OF TWO LAYERS.
C3	PROP. VAR. DEPTH ASPHALT CONCRETE SURFACE COURSE, TYPE S9.5B, AT AN AVERAGE RATE OF 110 LBS. PER SQ. YD. PER 1" DEPTH. TO BE PLACED IN LAYERS NOT LESS THAN 1" IN DEPTH OR GREATER THAN 1½" IN DEPTH.
D1	PROP. APPROX. 4" ASPHALT CONCRETE INTERMEDIATE COURSE, TYPE I19.0C, AT AN AVERAGE RATE OF 456 LBS. PER SQ. YD.
D2	PROP. VAR. DEPTH ASPHALT CONCRETE INTERMEDIATE COURSE, TYPE I19.0C, AT AN AVERAGE RATE OF 114 LBS. PER SQ. YD. PER 1" DEPTH TO BE PLACED IN LAYERS NOT LESS THAN 2½" IN DEPTH OR GREATER THAN 4" IN DEPTH.
E1	PROP. APPROX. 4" ASPHALT CONCRETE BASE COURSE, TYPE B25.0C, AT AN AVERAGE RATE OF 456 LBS. PER SQ. YD.
E2	PROP. VAR. DEPTH ASPHALT CONCRETE BASE COURSE, TYPE B25.0C, AT AN AVERAGE RATE OF 114 LBS. PER SQ. YD. PER 1" DEPTH TO BE PLACED IN LAYERS NOT LESS THAN 3" IN DEPTH OR GREATER THAN 5½" IN DEPTH.
J1	PROP. 6" AGGREGATE BASE COURSE.
R	SHOULDER BERM GUTTER.
T	EARTH MATERIAL.
U	EXISTING PAVEMENT.
W	WEDGING (SEE DETAIL SHOWING METHOD OF WEDGING).

NOTE: PAVEMENT EDGE SLOPES ARE 1:1 UNLESS SHOWN OTHERWISE.

P:\2018\20180623\B5639\Proj\B5639\_rdy\_tup.dgn  
 6/2/2019 10:13:13 AM