

**NOTES**

STIRRUPS IN CAP MAY BE SHIFTED AS NECESSARY TO CLEAR DOWELS.  
 THE CONCRETE IN THE SHADED AREA OF THE WING SHALL BE POURED AFTER THE VERTICAL CONCRETE BARRIER RAIL IS CAST IF SLIP FORMING IS USED.  
 FOR PILE SPLICE DETAILS, SEE SHEET 4 OF 4.  
 FOR WING DETAILS, SEE SHEET 3 OF 4.

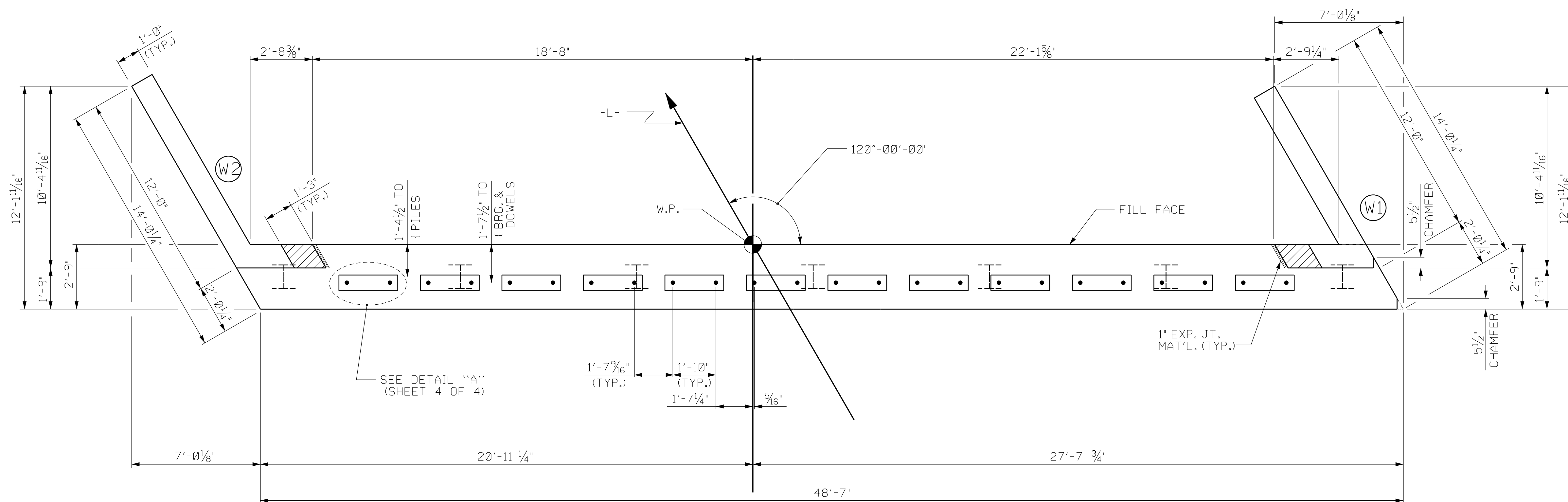

**PLAN**

TOP OF PILE ELEVATIONS	
①	2184.52
②	2184.31
③	2184.11
④	2183.90
⑤	2183.69
⑥	2183.49
⑦	2183.28

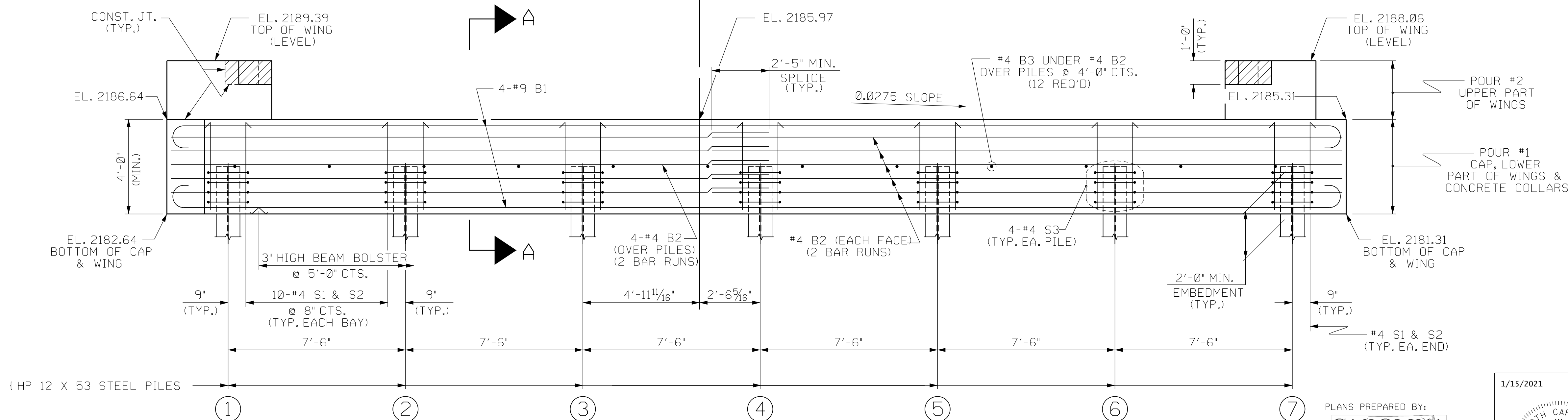

**ELEVATION**

WINGS NOT SHOWN FOR CLARITY.  
 FOR SECTION A-A, SEE SHEET 4 OF 4.  
 CONCRETE COLLARS FOR STEEL PILES NOT SHOWN IN PLAN AND ELEVATION VIEWS FOR CLARITY.  
 SEE "CORROSION PROTECTION FOR STEEL PILES DETAIL", SHEET 4 OF 4.

PROJECT NO. BR-0009  
BUNCOMBE COUNTY  
 STATION: 12+94.70 -L-

SHEET 2 OF 4

STATE OF NORTH CAROLINA  
 DEPARTMENT OF TRANSPORTATION  
 RALEIGH

SUBSTRUCTURE  
 END BENT No. 2



PLANS PREPARED BY:  
**CAROLINA**  
 Transportation  
 Engineers &  
 Architects, PC  
 4270 Belle Meade Circle  
 Belmont, NC 28012  
 (980) 722-6065  
 www.carolina-TEA.com  
 License No. C-4307

1/15/2021

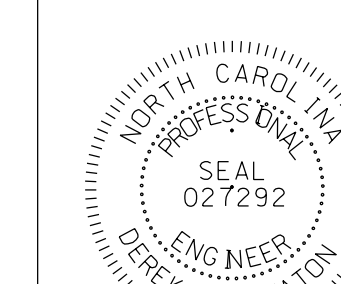

DocuSigned by:  
**Derek Staton**  
 573437191467442

DOCUMENT NOT CONSIDERED  
 FINAL UNLESS ALL  
 SIGNATURES COMPLETED

REVISIONS						SHEET NO.
NO.	BY:	DATE:	NO.	BY:	DATE:	S-13
1			3			TOTAL SHEETS
2			4			18

ASSEMBLED BY: J.D. BAKER	DATE: 01-20
CHECKED BY: D.C. STATON	DATE: 01-20
DRAWN BY: WJH 12/11	REV. 4/15
CHECKED BY: AAC 12/11	MAA/TMG