

TOP OF CAP

SPAN E
SPAN D

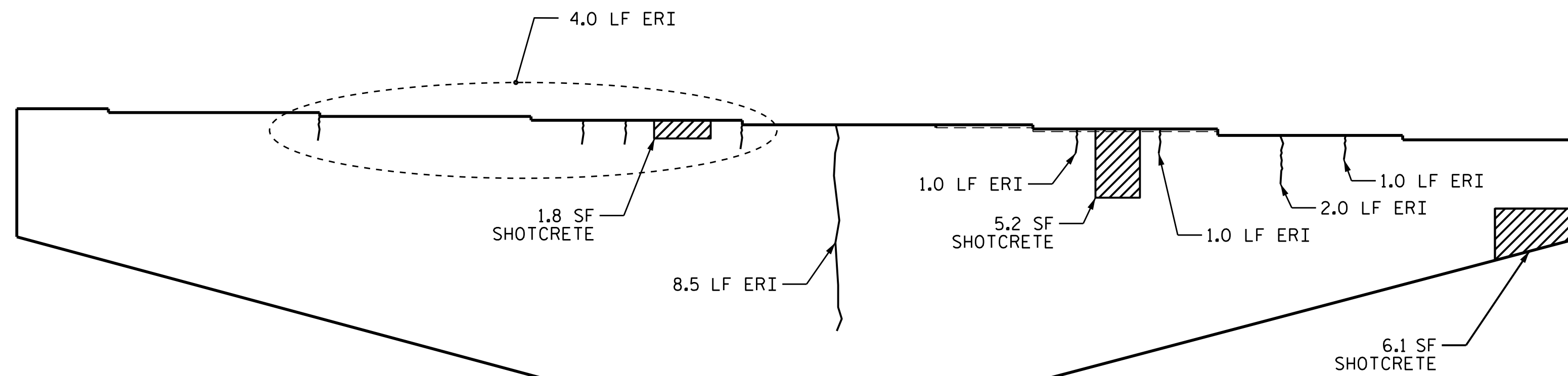

ELEVATION

← SPAN D | SPAN E →

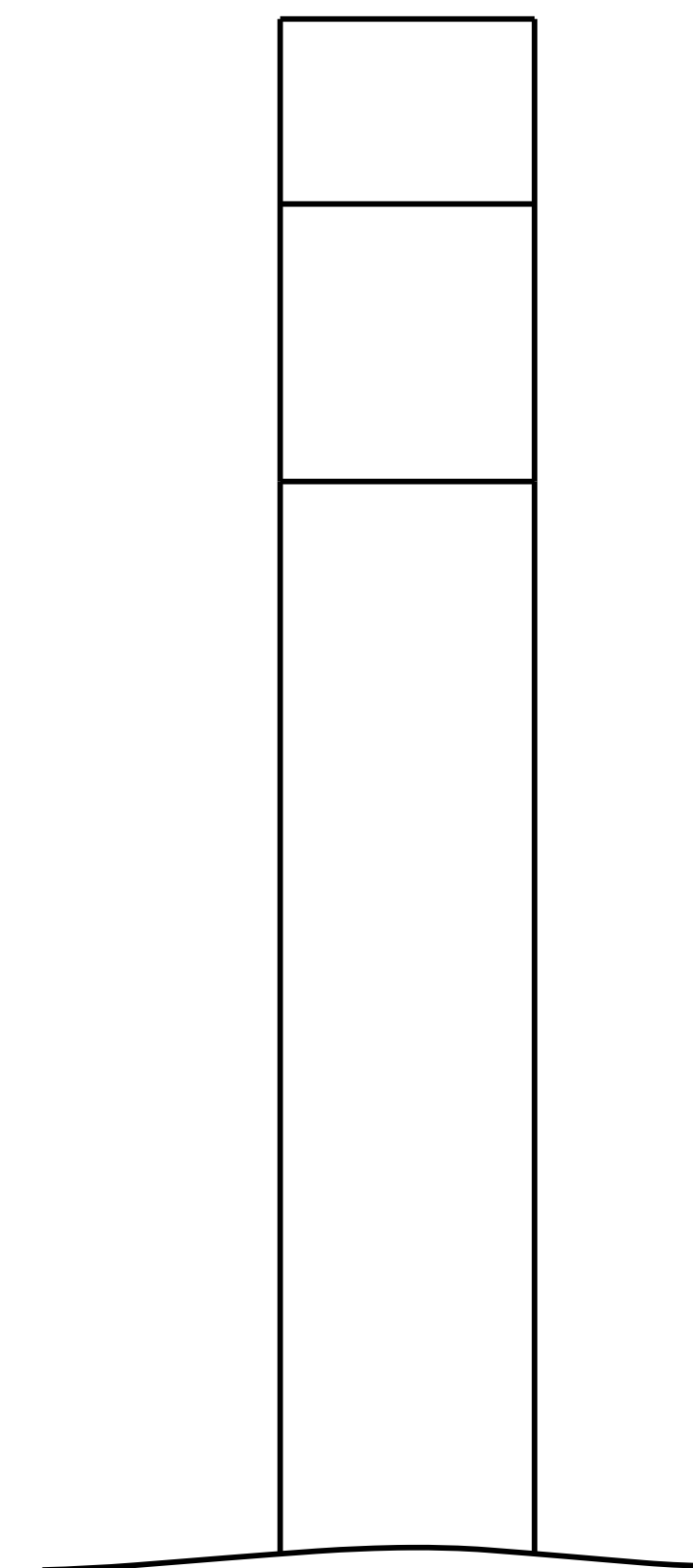

END VIEW

AS-BUILT REPAIR QUANTITY TABLE

BENT 4 SPAN D FACE	QUANTITIES			
	ESTIMATE		ACTUAL	
	AREA SQ. FT.	VOLUME CU. FT.	AREA SQ. FT.	VOLUME CU. FT.
SHOTCRETE REPAIRS				
CAP	13.1	6.6		
COLUMN	0.0	0.0		
CONCRETE REPAIRS				
CAP	3.8	1.9		
COLUMN	0.0	0.0		
EPOXY RESIN INJECTION		LIN. FT.		LIN. FT.
CAP		17.5		
COLUMN		0.0		
EPOXY COATING		SQ. FT.		SQ. FT.
TOP OF BENT CAP		355.0		

VALUES IN CHART REPRESENT ESTIMATED REPAIR TOTALS AFTER REMOVAL OF UNSOUND CONCRETE, MINIMUM OF 1" BEHIND REBAR AND MINIMUM 2" CLEARANCE TO SAWCUT. SEE "TYPICAL CAP AND COLUMN REPAIR DETAILS" SHEET.

NOTES

REPAIR LOCATIONS AND ESTIMATE OF QUANTITIES ARE GIVEN BASED ON THE BEST INFORMATION AVAILABLE. IF ADDITIONAL REPAIRS NOT SHOWN ON THE DRAWINGS ARE DEEMED NECESSARY BY THE ENGINEER, THE ENGINEER SHALL NOTE ON THE DRAWINGS THE APPROXIMATE LOCATION AND DESCRIPTION OF THE REPAIRS AND ENTER THE ACTUAL QUANTITIES INTO THE AS-BUILT REPAIR QUANTITY TABLE.

CLEAN AND REMOVE DEBRIS FROM THE TOP OF THE CAP AND APPLY EPOXY PROTECTIVE COATING. EPOXY COATING SHALL BE APPLIED TO THE TOP SURFACE OF THE CAP. THE CONTRACTOR SHALL NOT COAT THE AREA OF THE CAP BENEATH THE MASONRY PLATES. FOR EPOXY COATING, SEE SPECIAL PROVISIONS.

CONCRETE REPAIRS MAYBE SUBSTITUTED IN LIEU OF SHOTCRETE REPAIRS WITH THE APPROVAL OF THE ENGINEER.

- SHOTCRETE REPAIR AREA
- CONCRETE REPAIR AREA
- ERI - EPOXY RESIN INJECTION

PROJECT NO. 15BPR.40
BUNCOMBE COUNTY
 BRIDGE NO. 100705

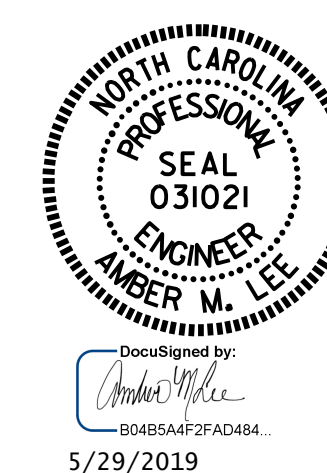

STATE OF NORTH CAROLINA
 DEPARTMENT OF TRANSPORTATION
 RALEIGH
 SUBSTRUCTURE REPAIR
 BENT 4
 SPAN D FACE

DRAWN BY : C. BRIGHT/M. G. SHAIKH DATE : 02/2019
 CHECKED BY : A. M. LEE DATE : 03/2019

DOCUMENT NOT CONSIDERED
 FINAL UNLESS ALL
 SIGNATURES COMPLETED

REVISIONS						SHEET NO.
NO.	BY:	DATE:	NO.	BY:	DATE:	
1			3			S3-30
2			4			TOTAL SHEETS 36