

NOTES

STIRRUPS IN CAP MAY BE SHIFTED AS NECESSARY TO CLEAR DOWELS.

THE CONCRETE IN THE SHADED AREA OF THE WING SHALL BE POURED AFTER THE VERTICAL CONCRETE BARRIER RAIL IS CAST IF SLIP FORMING IS USED.

FOR PILE SPLICE DETAILS, SEE SHEET 4 OF 4.

FOR WING DETAILS, SEE SHEET 3 OF 4.

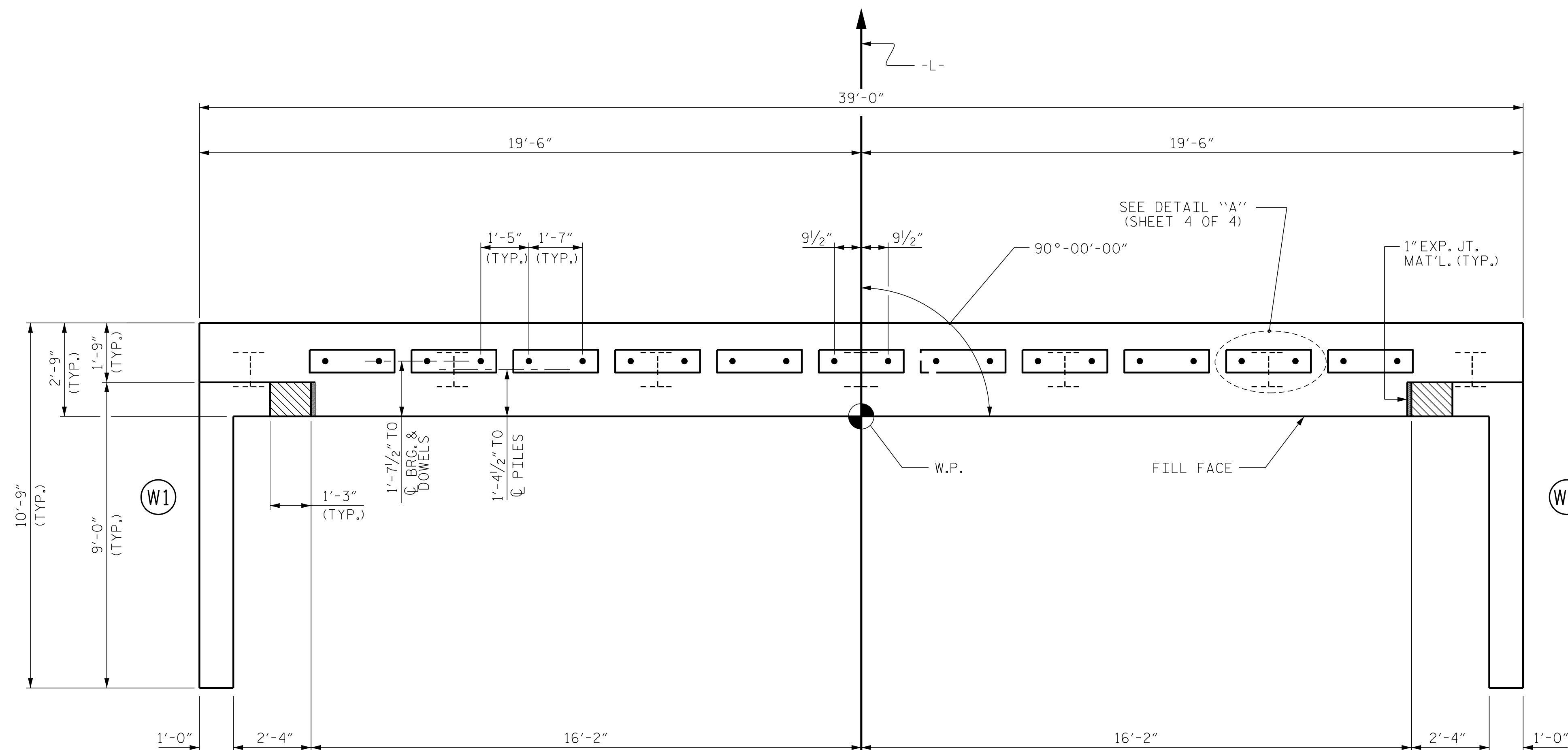

PLAN

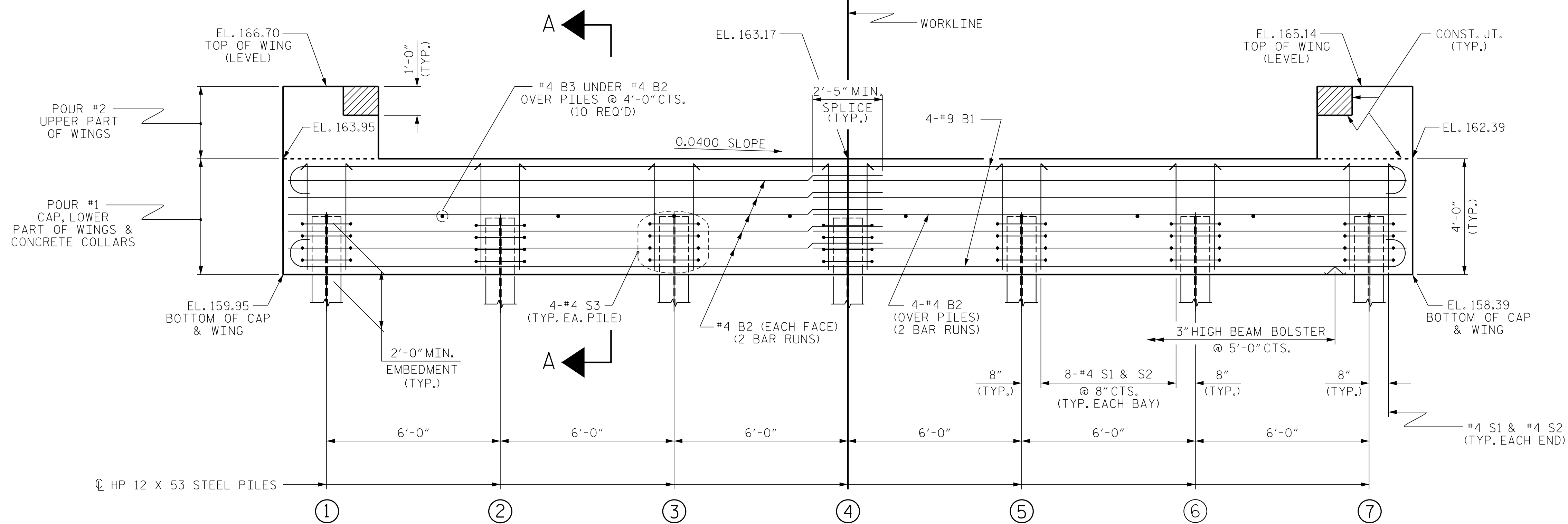

ELEVATION

WINGS NOT SHOWN FOR CLARITY.
FOR SECTION A-A, SEE SHEET 4 OF 4.
CONCRETE COLLARS FOR STEEL PILES NOT SHOWN IN PLAN AND ELEVATION VIEWS FOR CLARITY.
SEE "CORROSION PROTECTION FOR STEEL PILES DETAIL", SHEET 4 OF 4.

TOP OF PILE ELEVATIONS	
①	161.89
②	161.65
③	161.41
④	161.17
⑤	160.93
⑥	160.69
⑦	160.45

PROJECT NO. BR-0122
SAMPSON COUNTY
STATION: 16+08.00 -L-

SHEET 1 OF 4

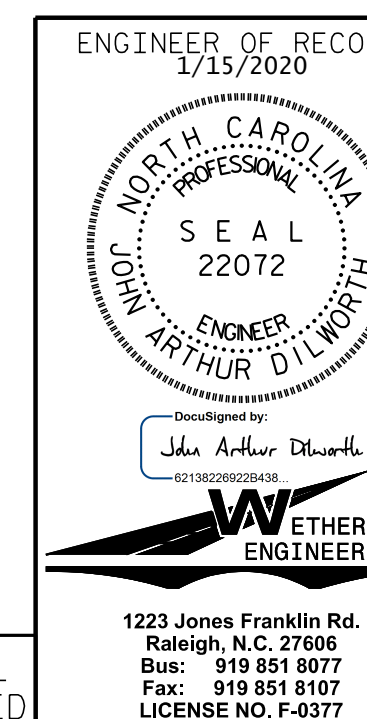

STATE OF NORTH CAROLINA
DEPARTMENT OF TRANSPORTATION
RALEIGH

SUBSTRUCTURE
END BENT No. 1

REVISIONS

NO.	BY:	DATE:	NO.	BY:	DATE:	SHEET NO.
1			3			S-8
2			4			TOTAL SHEETS 13

DOCUMENT NOT CONSIDERED FINAL
UNLESS ALL SIGNATURES COMPLETED

1223 Jones Franklin Rd.
Raleigh, N.C. 27606
Bus: 919 851 8077
Fax: 919 851 8107
LICENSE NO. F-0377

STD. NO. EB-33-90S4

P:\2019\19109\01_BR-0122 Structures\DWG\BR0122-SMJ_EB.dgn
 10/7/2019 1:55:39 PM

ASSEMBLED BY : J. PENDERGRAFT DATE : 2-19
 CHECKED BY : J. DILWORTH DATE : 4-19
 DRAWN BY : WJH 12/11
 CHECKED BY : AAC 12/11
 REV. 4/15 MAA/TMG