

FROM -L- STA. 82+70 TO -L- STA. 97+45 LT

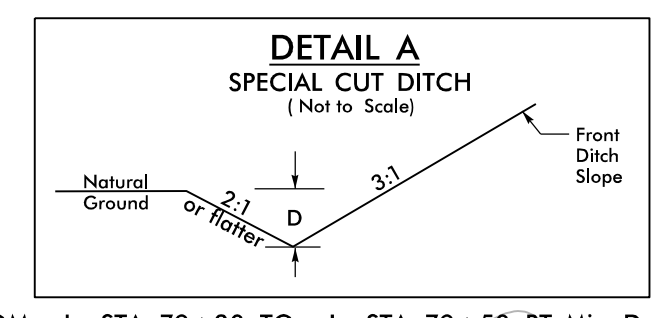

FROM -L- STA. 79+20 TO -L- STA. 79+50 RT Min. D=1.0 Ft.

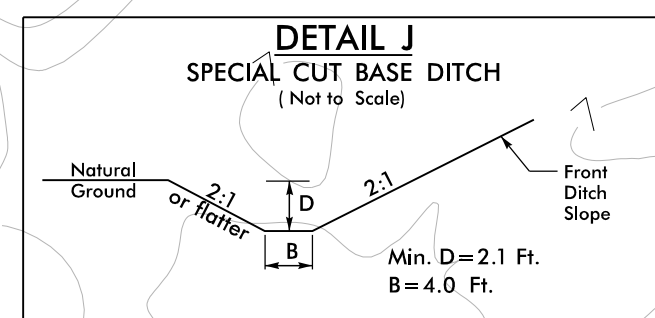

FROM -L- STA. 86+80 TO -L- STA. 104+30 RT

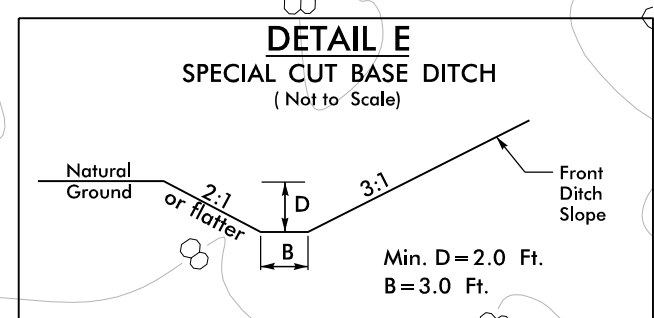

FROM -L- STA. 80+00 TO -L- STA. 80+45 RT

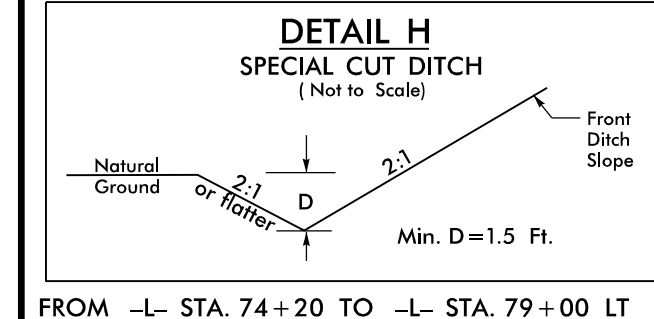

FROM -L- STA. 74+20 TO -L- STA. 79+00 LT
FROM -L- STA. 74+20 TO -L- STA. 79+20 RT

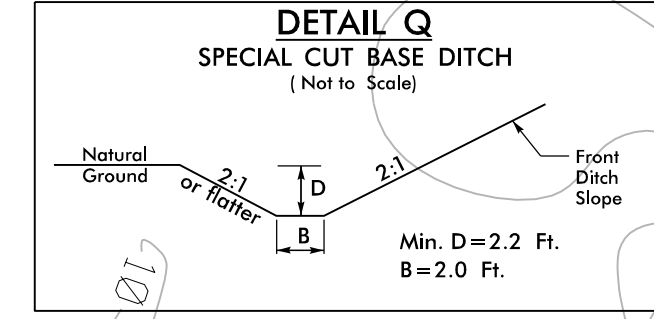

FROM -L- STA. 80+75 TO -L- STA. 81+45 LT

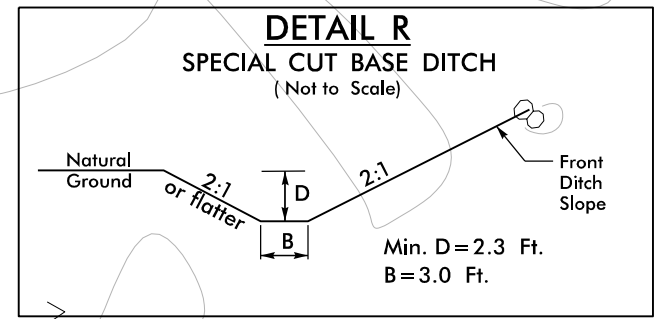

FROM -L- STA. 80+45 TO -L- STA. 86+20 RT

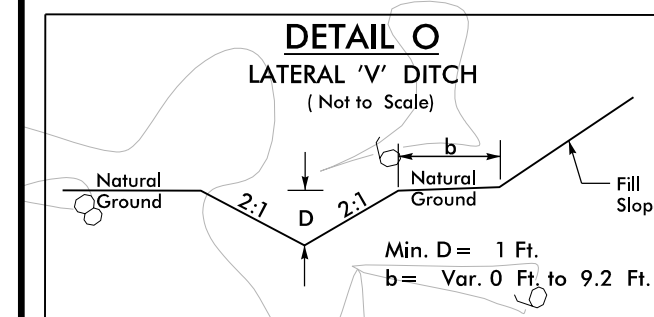

FROM -L- STA. 79+00 TO -L- STA. 79+66 LT

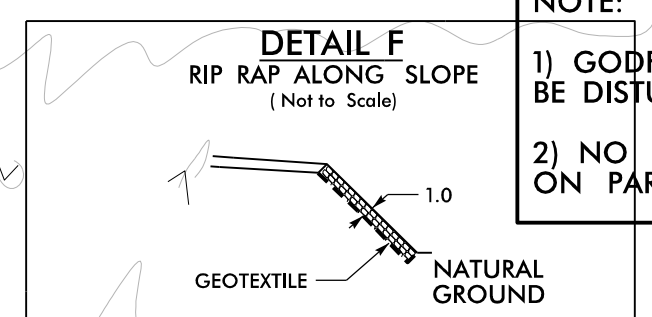

FROM -DR5- STA. 10+30 TO STA. 10+50 RT

NOTE:
1) GODFREY CEMETERY SIGN AND GRAVES NOT TO BE DISTURBED
2) NO HEAVY EQUIPMENT BEYOND PROPOSED RW ON PARCEL 37

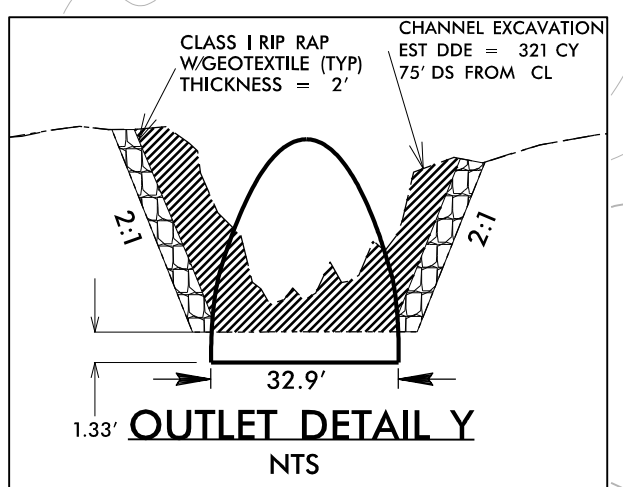
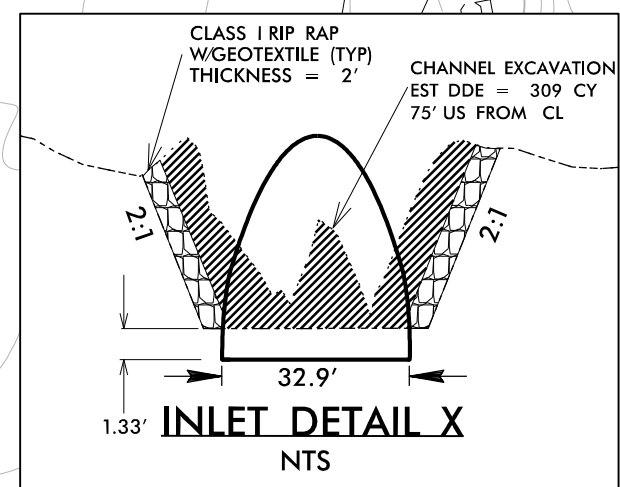
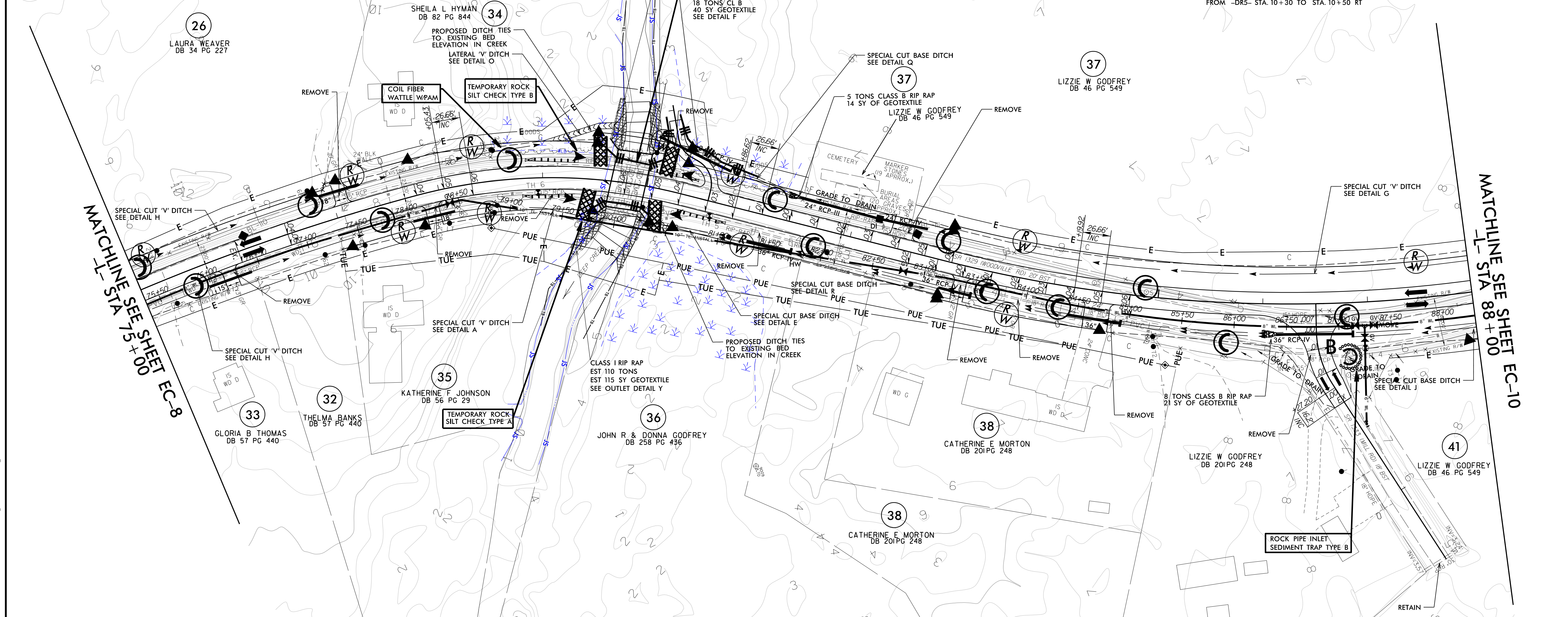

NOTE: PLACE TEMPORARY ROCK SEDIMENT DAMS TYPE - B AND TEMPORARY ROCK SILT CHECKS TYPE - A AT DRAINAGE OUTLETS.

CLEARING AND GRUBBING EROSION CONTROL FOR CONSTRUCTION SHEET 9

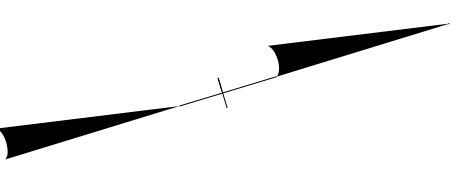

06-APR-2020 17:27 40\Hydr-eulics\CADD\PSH-E&S\EC-09\CONST.09.dgn