

EDI MODEL MMU2-16LEip MALFUNCTION MANAGEMENT UNIT PROGRAMMING DETAIL

(program card and tables as shown below)

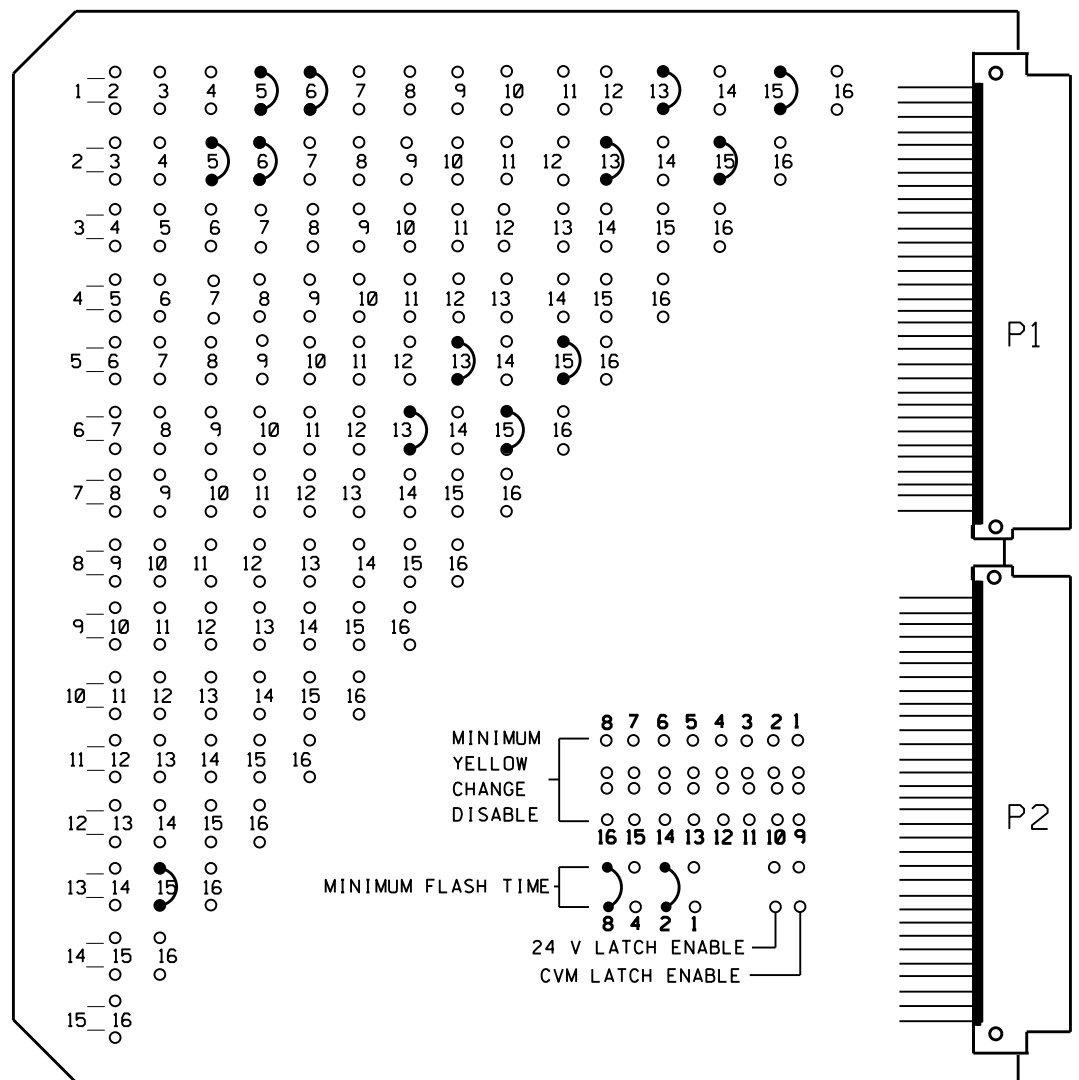

CHANNEL NUMBER	ENABLE/DISABLE
1	ENABLE
2	ENABLE
3	ENABLE
4	ENABLE
5	DISABLE
6	ENABLE
7	DISABLE
8	DISABLE
9	DISABLE
10	DISABLE
11	DISABLE
12	DISABLE
13	ENABLE
14	DISABLE
15	ENABLE
16	DISABLE

OPTION	SETTING
RECURRENT PULSE	ON
WALK DISABLE	OFF
LOG CVM FAULTS	ON
EXTERN WATCHDOG	OFF
24V-2=12VDC	OFF
PGM CARD MEMORY	ON
LEDguard	ON
FORCE TYPE 16	OFF
TYPE12-SDLCL	OFF
VM 3x/Day Latch	ON

OPTION	SETTING
FLASHING YELLOW ARROW	
CONFIG MODE	B
ENABLE CHANNEL PAIR, FYA	
CH 1-13	ON
CH 3-14	OFF
CH 5-15	ON
CH 7-16	OFF
RED/YEL INPUT ENABLE	
CH 1	ON
CH 3	OFF
CH 5	ON
CH 7	OFF
FLASH RATE FAULT	ON
FYA TRAP DETECT	ON

MMU PROGRAMMING CARD

MMU PROGRAMMING NOTE
ENSURE YELLOW CHANGE PLUS RED CLEARANCE MONITORING IS ENABLED FOR ALL CHANNELS.

SIGNAL HEAD HOOK-UP CHART																			
PHASE	1	2	3		4		5	6	7	8	2 PED	4 PED	6 PED	8 PED	OLA	OLB	OLC	OLD	
SIGNAL HEAD NO.	11★	42	21,22	31,32	33,34	62	22	41	42,43	51★	61,62	NU	NU	NU	NU	11★	NU	51★	NU
RED	*	2R	3R					4R	4R	*	6R								
YELLOW		2Y	3Y					4Y	4Y	*	6Y								
GREEN		2G	3G					4G	4G		6G								
RED ARROW			3R													13R		15R	
YELLOW ARROW		1Y	3Y	3Y	4Y											13Y		15Y	
FLASHING YELLOW ARROW																13G		15G	
GREEN ARROW	1G	1G	3G	3G	4G	4G		5G											
Hand icon																			
Walking person icon																			

NU = Not Used
* Denotes install load resistor. See Load Resistor Installation Detail on sheet 2.
★ See pictorial of head wiring detail this sheet.

DETECTOR RACK SET-UP DETAIL

INSERT DETECTOR CARDS IN RACK ACCORDING TO THE DETAIL SHOWN BELOW. PARTICULAR DETECTOR CHANNELS WILL CALL PHASES INDICATED.

RACK #1	BIU	CH1	CH1	SLOT	CH1	SLOT	CH1	SLOT	SLOT	SLOT	SLOT	SLOT
		L3	L1	∅ 1	L5	NOT USED	L9	∅ 5	∅ 1	∅ 1	∅ 1	∅ 1
		∅ 1	∅ 1		∅ 4		L10	∅ 2				
		CH2	CH2	EMPTY	CH2	EMPTY	CH2	EMPTY	EMPTY	EMPTY	EMPTY	EMPTY
		NOT USED	∅ 6		∅ 4		∅ 2					

WIRE LOOPS TO TERMINALS ON LOOP PANEL AS SHOWN IN THE CHART BELOW

LOOP NO.	LOOP PANEL TERMINALS
1A	L1A, L1B
	L2A, L2B
1B	L3A, L3B
NU	L4A, L4B
NU	L5A, L5B
4A	L6A, L6B
NU	L7A, L7B
NU	L8A, L8B
5A	L9A, L9B
	L10A, L10B
NU	L11A, L11B
NU	L12A, L12B
NU	L13A, L13B
NU	L14A, L14B
NU	L15A, L15B
NU	L16A, L16B

PROGRAM CONTROLLER DETECTORS ACCORDING TO THE SCHEDULE SHOWN IN THE CHART BELOW

CONTROLLER DETECTOR NO.	FUNCTION	TIMING	
		FEATURE	TIME (SEC)
1	∅ 1	DELAY	15
* 2	∅ 6	DELAY	3
3	∅ 1	DELAY	15
4			
5			
6	∅ 4		
7			
8			
9	∅ 5	DELAY	15
* 10	∅ 2	DELAY	3
11			
12			
13			
14			
15			
16			

* Detector Type - G (remove delay from existing detector card)

SPECIAL DETECTOR NOTE

Install a video detection system for vehicle detection. Perform installation according to manufacturer's directions and NCDOT engineer-approved mounting locations to accomplish the detection schemes shown on the Signal Design Plans for zones 1A, 2A, 2B, 3A, 3B, 3C, 5A, 6A, and 6B.

For Detection Zones 1A and 5A, the equipment placement and slots reserved for wired inputs are typical for a NCDOT installation.

FYA SIGNAL WIRING DETAIL

(wire signal heads as shown)

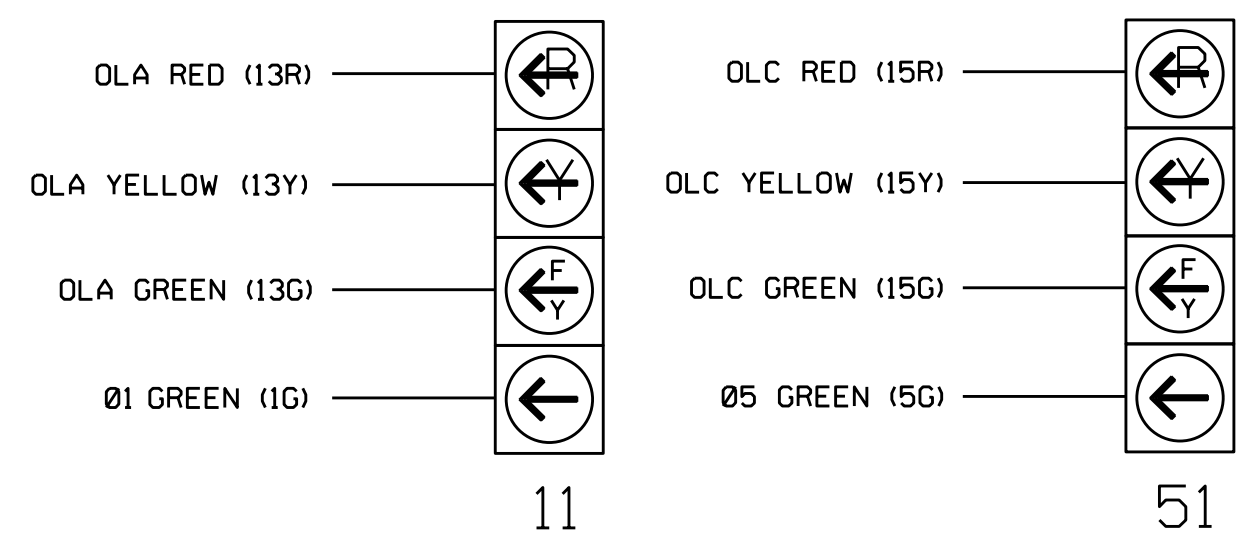

THIS ELECTRICAL DETAIL IS FOR THE SIGNAL DESIGN: 05-1726T1
DESIGNED: March 2019
SEALED: 7/24/2019
REVISED: N/A

EQUIPMENT INFORMATION

CONTROLLER.....2070EN2
CABINETNC-8 [TS-2]
SOFTWAREECONOLITE ASC/3-2070
CABINET MOUNT.....BASE
LOADBAY POSITIONS.....16
LOAD SWITCHES USED.....1,2,3,4,5,6,13,15
PHASES USED.....1,2,3,4,5,6
OLA.....*
OLB.....NOT USED
OLC.....*
OLD.....NOT USED
* SEE OVERLAP PROGRAMMING DETAIL ON SHEET 2

LOAD SWITCH ASSIGNMENT DETAIL

(program controller according to schedule in chart below)

LOAD SWITCH NUMBER	FUNCTION
1	∅ 1
2	∅ 2
3	∅ 3
4	∅ 4
5	∅ 5
6	∅ 6
7	∅ 7
8	∅ 8
9	∅ 2 PED
10	∅ 4 PED
11	∅ 6 PED
12	∅ 8 PED
13	OLA
14	OLB
15	OLC
16	OLD

NOTES

- To prevent "flash-conflict" problems, wire all unused load switches to flash red. Verify that signal heads flash in accordance with the signal plans.
- To prevent red failures on unused monitor channels, tie unused load switch red outputs 7,8,9,10,11,12,14, and 16 to load switch AC+ by inserting a jumper plug in the unused load switch socket from pin 1 (LS AC+) to pin 3 (RED out). Make sure all flash transfer relays are in place.
- Program controller to start up in phase 2 Green and 6 Green.
- Set power-up flash time to 10 seconds and implement on the Malfunction Management Unit. Set controller power-up flash time to 0 seconds.
- Enable simultaneous gap-out feature for all phases.
- Program detectors in accordance with the manufacturer's instructions to accomplish the detection schemes shown on the signal design plans.
- Program detector call delay and extension timing on the controller, unless otherwise specified.
- Set all detector card unit channels to "presence" mode.
- Program phases 2 and 6 for volume density operation.
- The cabinet and controller are a part of the Cary Signal System.

Electrical Detail - Temp 1 (TMP Phase I, Step A)
Sheet 1 of 2

	SR 3015 (Airport Blvd.) at Factory Shops Road/ Aerial Center Parkway	SEAL RYAN W. HOUGH ENGINEER 036833
	Division 5 Wake County Morrisville PLAN DATE: May 2019 REVIEWED BY: PREPARED BY: S. Armstrong REVIEWED BY:	REVISIONS: _____ INIT. DATE _____ _____ _____

05-1726T1-01-08-16
 S:\Projects\15_Signal\work\hough\051726_sml.ele.xxx.dgn
 S:\Projects\15_Signal\work\hough\051726_sml.ele.xxx.dgn
 S:\Projects\15_Signal\work\hough\051726_sml.ele.xxx.dgn
 S:\Projects\15_Signal\work\hough\051726_sml.ele.xxx.dgn