

**EDI MODEL MMU2-16LEip
MALFUNCTION MANAGEMENT UNIT
PROGRAMMING DETAIL**

(program card and tables as shown)

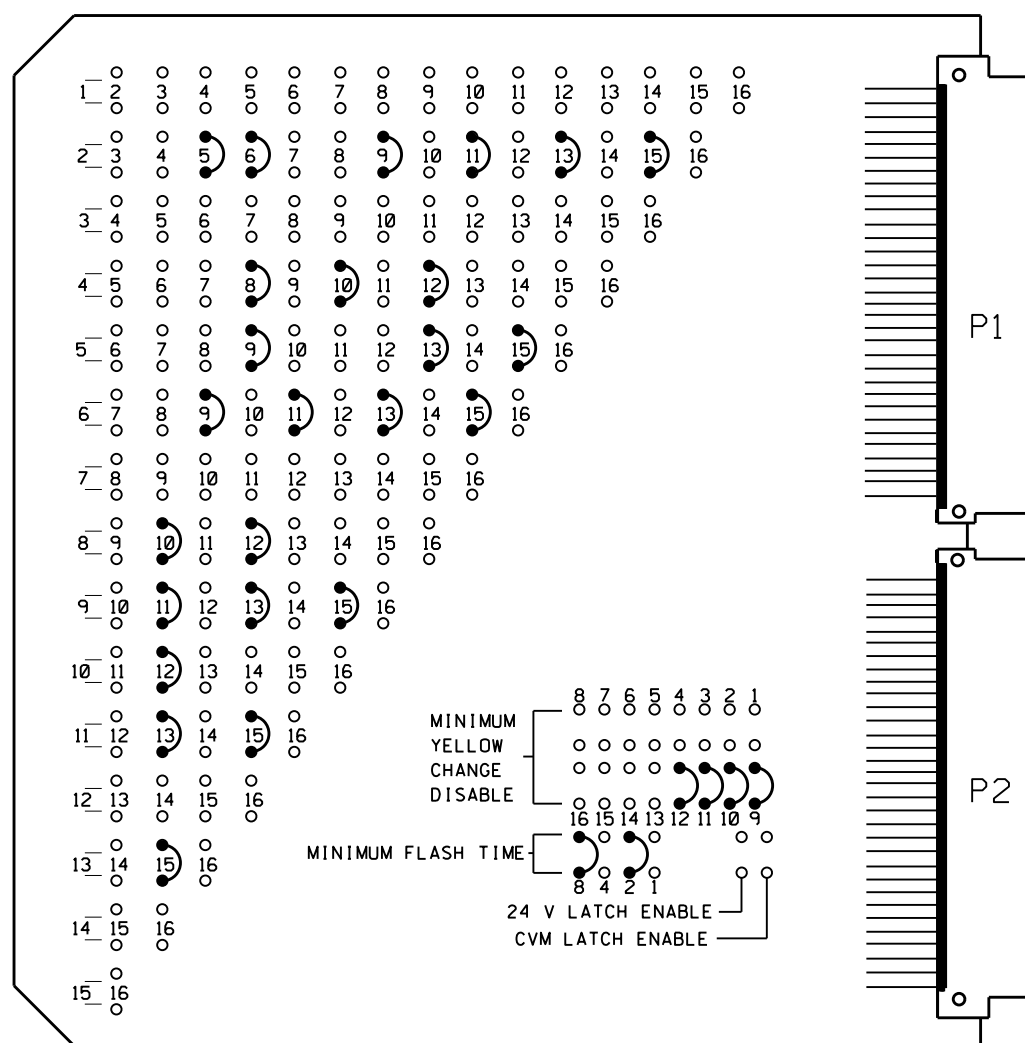

MMU PROGRAMMING CARD

**FIELD CHECK ENABLE
DUAL IND ENABLE
RED FAIL ENABLE**

CHANNEL NUMBER	ENABLE/DISABLE
1	DISABLE
2	ENABLE
3	DISABLE
4	ENABLE
5	ENABLE
6	ENABLE
7	DISABLE
8	ENABLE
9	ENABLE
10	ENABLE
11	ENABLE
12	ENABLE
13	ENABLE
14	DISABLE
15	ENABLE
16	DISABLE

UNIT OPTIONS

OPTION	SETTING
RECURRENT PULSE	ON
WALK DISABLE	OFF
LOG CVM FAULTS	ON
EXTERN WATCHDOG	OFF
24V-2=12VDC	OFF
PGM CARD MEMORY	ON
LEDguard	ON
FORCE TYPE 16	OFF
TYPE12-SDLIC	OFF
VM 3x/Day Latch	ON

FLASHING YELLOW ARROW

ENABLE CHANNEL PAIR, FYA	
CH 1-13	ON
CH 3-14	OFF
CH 5-15	ON
CH 7-16	OFF
RED/YEL INPUT ENABLE	
CH 1	ON
CH 3	OFF
CH 5	ON
CH 7	OFF
FLASH RATE FAULT	ON
FYA TRAP DETECT	ON

MMU PROGRAMMING NOTE
ENSURE YELLOW CHANGE PLUS RED CLEARANCE MONITORING IS ENABLED FOR ALL CHANNELS.

NOTES

- To prevent "flash-conflict" problems, wire all unused load switches to flash red. Verify that signal heads flash in accordance with the signal plans.
- To prevent red failures on unused monitor channels, tie unused load switch red outputs 1, 3, 7, 14 and 16 to load switch AC+ by inserting a jumper plug in the unused load switch socket from pin 1 (LS AC+) to pin 3 (RED out). Make sure all flash transfer relays are in place.
- Program controller to start up in phase 2 Walk and 6 Walk.
- Set power-up flash time to 10 seconds and implement on the Malfunction Management Unit. Set controller power-up flash time to 0 seconds.
- Enable simultaneous gap-out feature for all phases.
- Program phases 2 and 6 for volume density operation.
- Program detectors in accordance with the manufacturer's instructions to accomplish the detection schemes shown on the signal design plans.
- Program detector call delay and extension timing on the controller, unless otherwise specified.
- Set all detector card unit channels to "presence" mode.
- Program phases 4 and 8 for dual entry.
- The cabinet and controller are a part of the Cary Signal System.

SIGNAL HEAD HOOK-UP CHART

PHASE	1	2	3	4	5	6	7	8	2 PED	4 PED	6 PED	8 PED	OLA	OLB	OLC	OLD	
SIGNAL HEAD NO.	NU	21,22	NU	41,42	42	51*	62,63	NU	81,82	P21, P22	P41, P42	P61, P62	P81, P82	61*	NU	51*	NU
RED		2R		4R		*	6R		8R								
YELLOW		2Y		4Y			6Y		8Y								
GREEN		2G		4G			6G		8G								
RED ARROW														13R		15R	
YELLOW ARROW					5Y									13Y		15Y	
FLASHING YELLOW ARROW														13G		15G	
GREEN ARROW					5G	5G											
Hand icon										9R	10R	11R	12R				
Person icon										9G	10G	11G	12G				

NU = Not Used
* Denotes install load resistor. See Load Resistor Installation Detail below.
* See pictorial of head wiring detail this sheet.

DETECTOR RACK SET-UP DETAIL

INSERT DETECTOR CARDS IN RACK ACCORDING TO THE DETAIL SHOWN BELOW. PARTICULAR DETECTOR CHANNELS WILL CALL PHASES INDICATED.

RACK #1	BIU	SLOT	CH1	CH1	CH1	SLOT	SLOT	SLOT	SLOT	SLOT	SLOT
			L1	L5	L9						
			∅ 2	∅ 5	∅ 2	NOT USED					
		**	**	*	∅ 8						
		EMPTY	EMPTY	EMPTY	EMPTY	EMPTY	EMPTY	EMPTY	EMPTY	EMPTY	EMPTY

EQUIPMENT INFORMATION

CONTROLLER.....2070EN2
CABINET[TS-2]
SOFTWAREECONOLITE ASC/3-2070
CABINET MOUNT.....BASE
LOADBAY POSITIONS.....16
LOAD SWITCHES USED.....2,4,5,6,8,9,10,11,12,13,15
PHASES USED.....2,2PED,4,4PED,5,6,6PED,8,8PED
OLA.....*
OLB.....NOT USED
OLC.....*
OLD.....NOT USED

* See overlap programming detail on sheet 2

FYA SIGNAL WIRING DETAIL

(wire signal heads as shown)

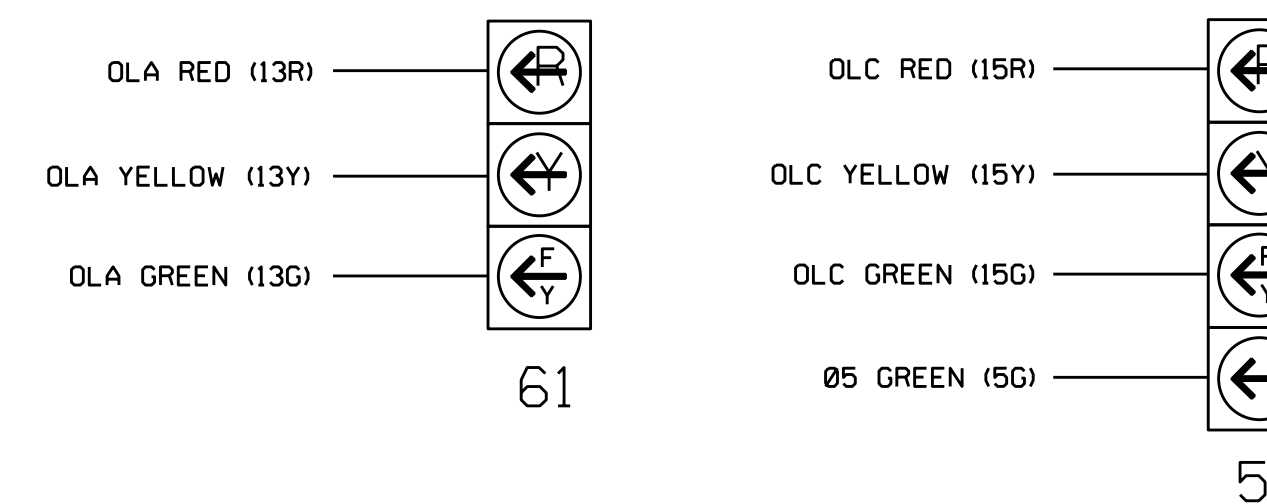

WIRE LOOPS TO TERMINALS ON LOOP PANEL AS SHOWN IN THE CHART BELOW

LOOP NO.	LOOP PANEL TERMINALS
2A	L1A,L1B
2B	L2A,L2B
NU	L3A,L3B
NU	L4A,L4B
5A	L5A,L5B
NU	L6A,L6B
NU	L7A,L7B
NU	L8A,L8B
NU	L9A,L9B
8A	L10A,L10B
NU	L11A,L11B
NU	L12A,L12B
NU	L13A,L13B
NU	L14A,L14B
NU	L15A,L15B
NU	L16A,L16B

ADD JUMPERS FROM: L5A TO L6A, AND L5B TO L6B

PROGRAM CONTROLLER DETECTORS ACCORDING TO THE SCHEDULE SHOWN IN THE CHART BELOW

CONTROLLER DETECTOR NO.	FUNCTION	TIMING	
		FEATURE	TIME (SEC)
** 1	∅ 2		
** 2	∅ 2		
3			
4			
5	∅ 5	DELAY	15
* 6	∅ 2	DELAY	3
7			
8			
9			
10	∅ 8	DELAY	5
11			
12			
13			
14			
15			
16			

NOTE

BE SURE TO PROGRAM DETECTOR TYPES AND TIMERS (EXTEND AND DELAY) AS SHOWN ON THE SIGNAL PLANS.

* Detector Type - G
** Detector Type - N

LOAD SWITCH ASSIGNMENT DETAIL

(program controller according to schedule in chart below)

LOAD SWITCH NUMBER	FUNCTION
1	∅ 1
2	∅ 2
3	∅ 3
4	∅ 4
5	∅ 5
6	∅ 6
7	∅ 7
8	∅ 8
9	∅ 2 PED
10	∅ 4 PED
11	∅ 6 PED
12	∅ 8 PED
13	OLA
14	OLB
15	OLC
16	OLD

LOAD RESISTOR INSTALLATION DETAIL

(install resistor as shown)

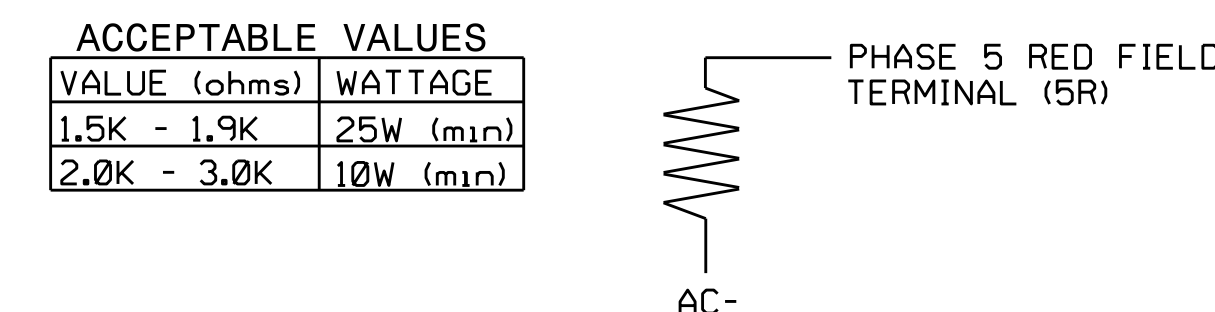

THIS ELECTRICAL DETAIL IS FOR THE SIGNAL DESIGN: 05-2088T1
DESIGNED: February 2019
SEALED: 7/24/2019
REVISED: N/A

SPECIAL DETECTOR NOTE

Install a video detection system for vehicle detection. Perform installation according to manufacturer's directions and NCDOT engineer-approved mounting locations to accomplish the detection schemes shown on the Signal Design Plans for zones 4A, 5B, 6A, 6B, and 6C.

For Detection Zone 5A the equipment placement and slots reserved for wired inputs are typical for a NCDOT installation.

Electrical Detail - Temp Design 1 (TMP Phase I, Step A)
Sheet 1 of 2

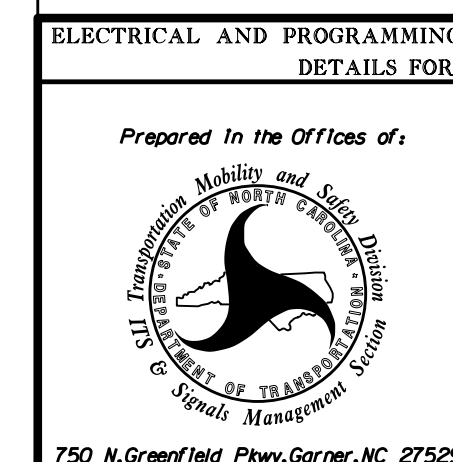

SR 3015 (Airport Boulevard)
at
SR 1641 (Slater Road)

Division 5 Wake County Morrisville

PLAN DATE: May 2019 REVIEWED BY:
PREPARED BY: S. Armstrong REVIEWED BY:

REVISIONS INIT. DATE

DOCUMENT NOT CONSIDERED FINAL UNLESS ALL SIGNATURES COMPLETED

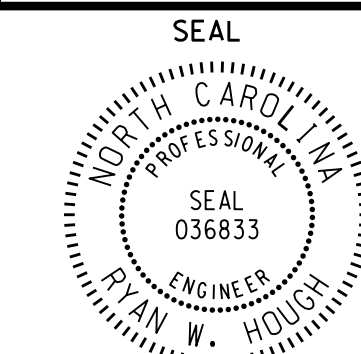

8/1/2019

SIG. INVENTORY NO. 05-2088T1