

PHASING DIAGRAM

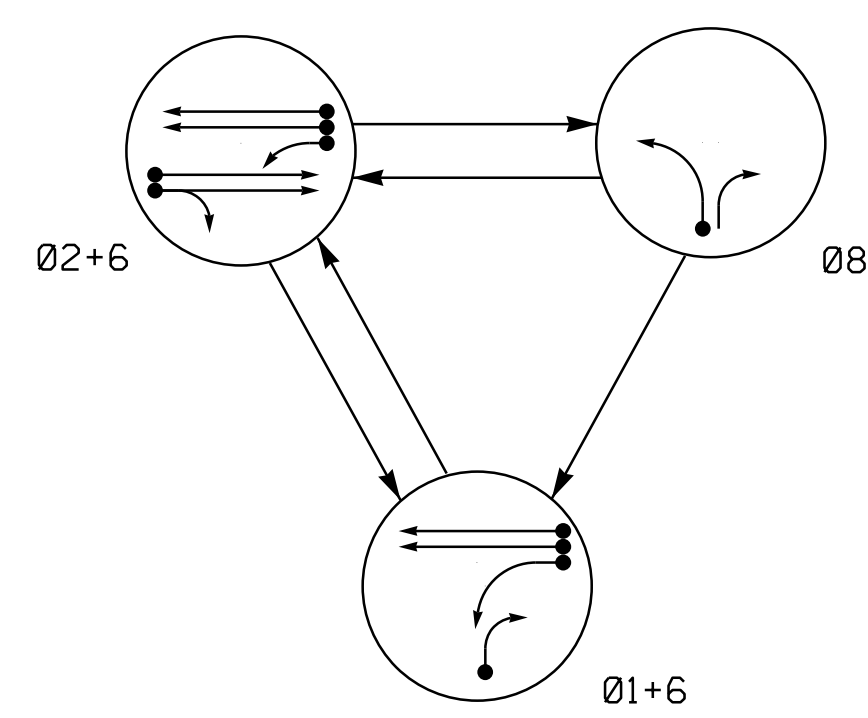
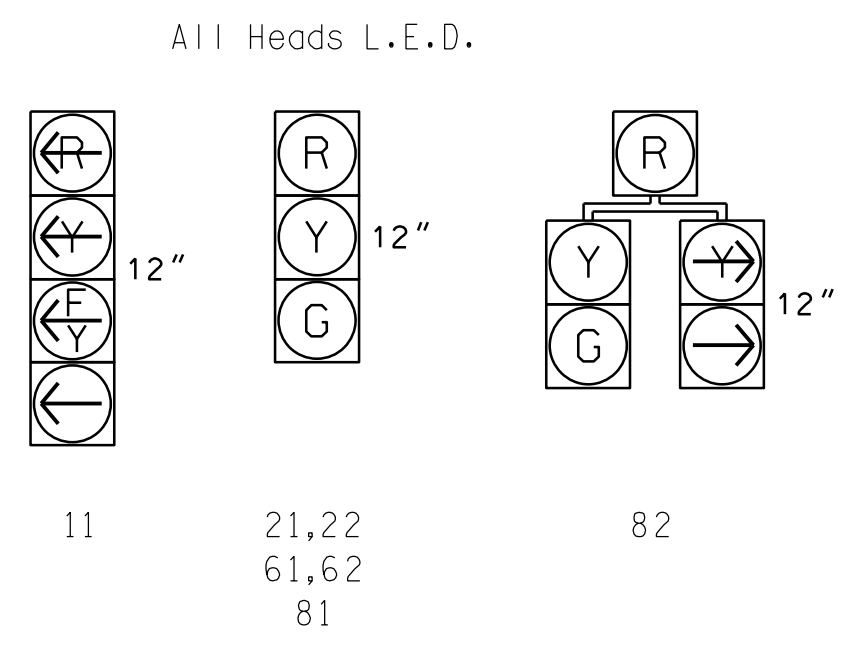

TABLE OF OPERATION table with columns for SIGNAL FACE and PHASE (0, 1, 2, 8, F, L, S, H).

SIGNAL FACE I.D.



OASIS 2070 LOOP & DETECTOR INSTALLATION CHART table with columns for LOOP/ZONE, SIZE, DISTANCE, TURNS, PHASE, CALLING, EXTENSION, FULL TIME DELAY, STRETCH TIME, DELAY TIME, SYSTEM LOOP, NEW CARD.

* Multizone Microwave Detection

3 Phase Fully Actuated Isolated

NOTES

- 1. Refer to "Roadway Standard Drawings NCDOT" dated January 2018 and "Standard Specifications for Roads and Structures" dated January 2018.
2. Do not program signal for late night flashing operation unless otherwise directed by the Engineer.
3. Phase 1 may be lagged.
4. Set all detector units to presence mode.
5. Locate new cabinet so as not to obstruct sight distance of vehicles turning right on red.
6. See pavement marking plans for stop bar locations.
7. Provide the Engineer with the Manufacturer's approved Microwave Detection locations and mounting heights to obtain detection zones as shown.

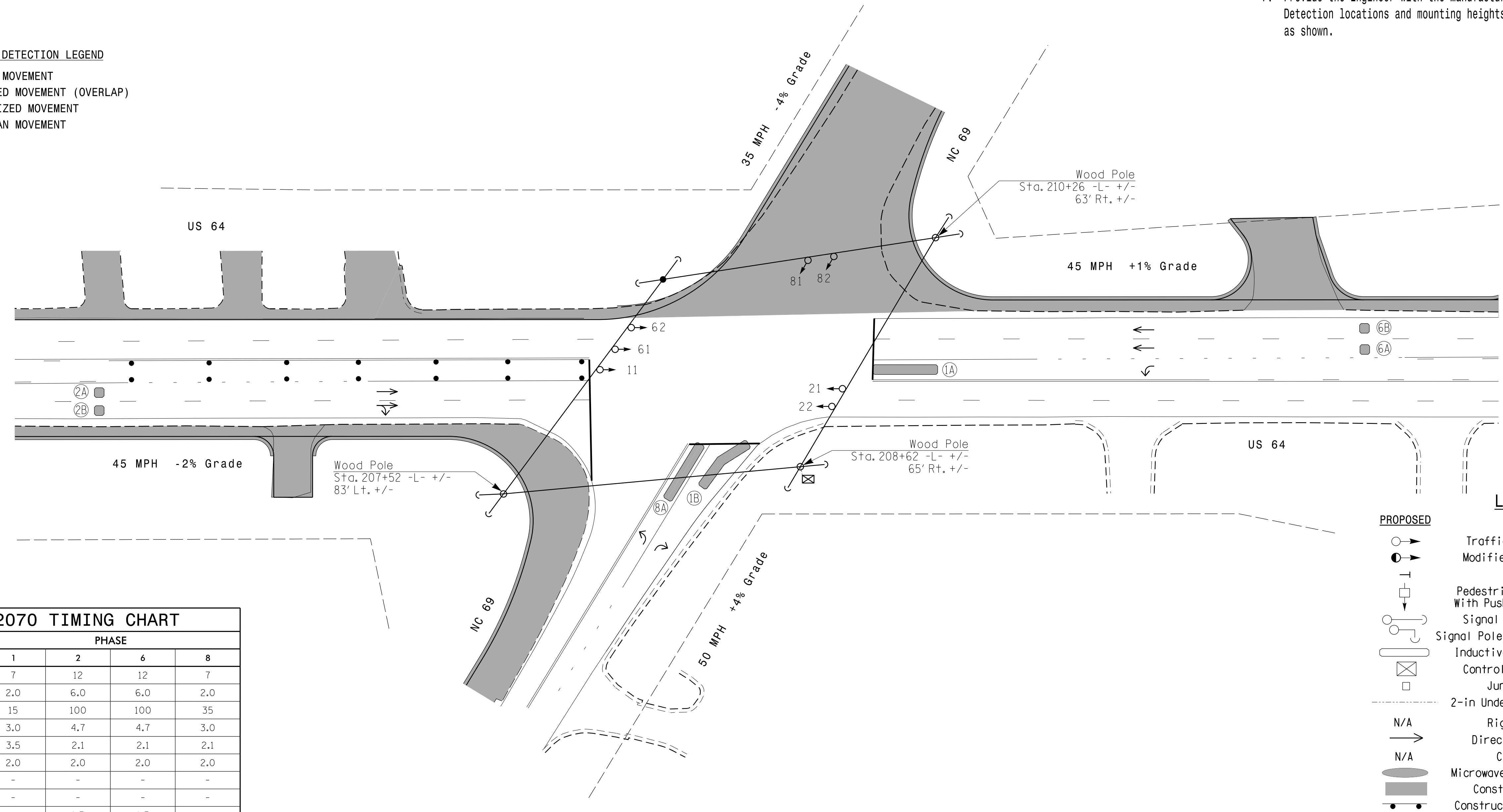
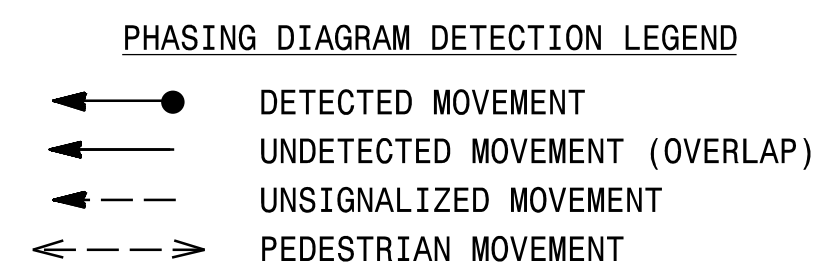

OASIS 2070 TIMING CHART table with columns for FEATURE and PHASE (1, 2, 6, 8).

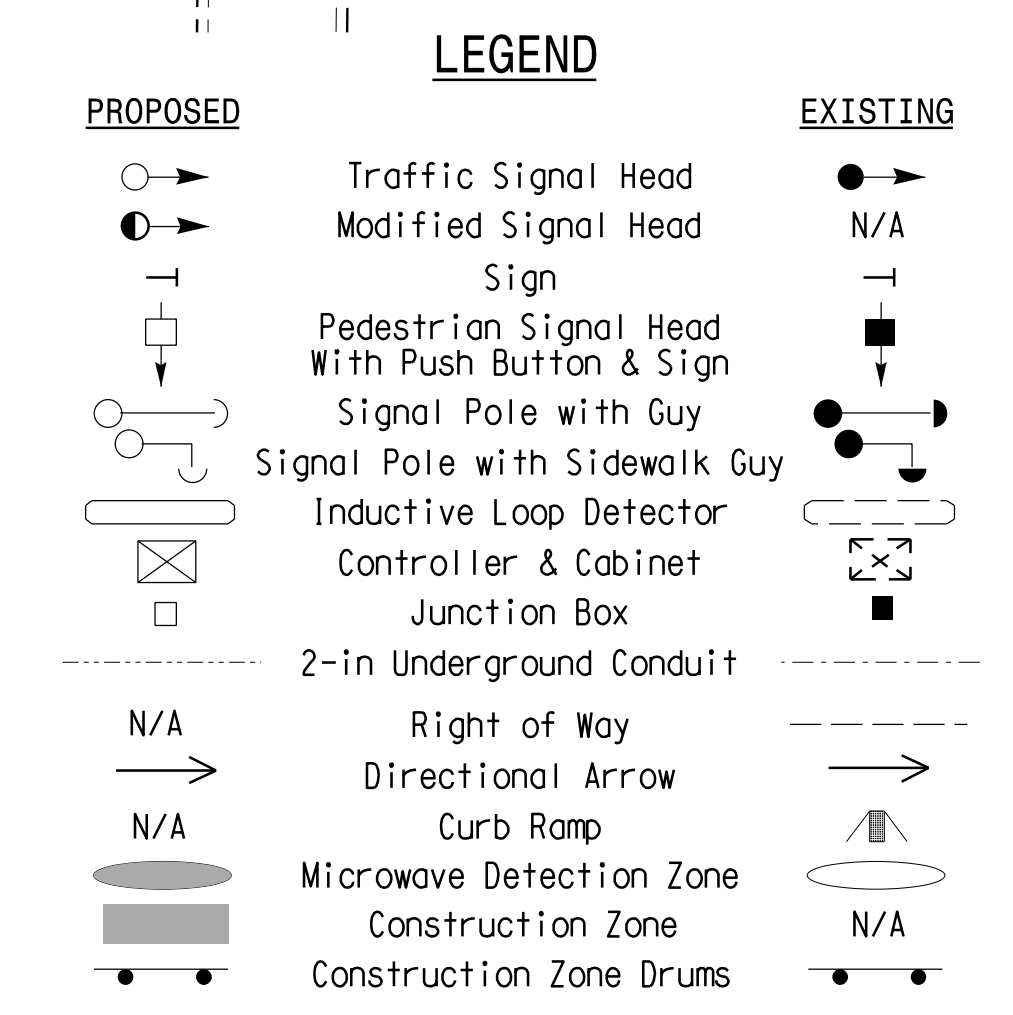

Signal Upgrade - Temporary Design 1 (Phase I)

RAMEY KEMP & ASSOCIATES, INC. logo and address information: 8307 University Executive Park Drive, Suite 200, Charlotte, North Carolina 28262.

Professional Engineer seal for Nicholas E. Burns, State of North Carolina, License No. 046300.

Project information: US 64 at NC 69, Division 14 Clay County Hayesville, prepared by TS Popelka, reviewed by NE Burns, dated September 2019.

Document control information: DOCUMENT NOT CONSIDERED FINAL UNLESS ALL SIGNATURES COMPLETED, SEAL, and inventory number 14-0195T1.