

TIP NO.	SHEET NO.
R-3421A	PMP-1
APPROVED: <i>Andrew D. Klinksieck</i> <small>E3D78FB486E44B</small>	
DATE: 7/5/2019	
	
DOCUMENT NOT CONSIDERED FINAL UNLESS ALL SIGNATURES COMPLETED	

**STATE OF NORTH CAROLINA  
DEPARTMENT OF TRANSPORTATION**

**PAVEMENT MARKING PLAN  
RICHMOND COUNTY**

**LOCATION: US 220 BYPASS FROM US 74 BYPASS WEST OF  
ROCKINGHAM AT SR 1109 (ZION CHURCH RD.)  
INTERCHANGE TO 0.3 MILES SOUTH OF SR 1140  
(OLD CHARLOTTE HWY.)**

**T.I.P.: R-3421A**

**CONTRACT: C204368**

**ROADWAY STANDARD DRAWING**

THE FOLLOWING ROADWAY STANDARDS AS APPEAR IN "ROADWAY STANDARD DRAWINGS" - CONTRACT STANDARDS AND DEVELOPMENT UNIT - N.C. DEPARTMENT OF TRANSPORTATION - RALEIGH, N.C., DATED JANUARY 2018 ARE APPLICABLE TO THIS PROJECT AND BY REFERENCE HEREBY ARE CONSIDERED A PART OF THESE PLANS:

STD. NO.	TITLE
1205.01	PAVEMENT MARKINGS - LINE TYPES AND OFFSETS
1205.02	PAVEMENT MARKINGS - TWO-LANE AND MULTILANE ROADWAYS
1205.03	PAVEMENT MARKINGS - EXIT AND ENTRANCE RAMP
1205.04	PAVEMENT MARKINGS - INTERSECTIONS
1205.05	PAVEMENT MARKINGS - TURN LANES
1205.06	PAVEMENT MARKINGS - LANE DROPS
1205.08	PAVEMENT MARKINGS - SYMBOLS AND WORD MESSAGES
1205.09	PAVEMENT MARKINGS - PAINTED ISLANDS
1205.12	PAVEMENT MARKINGS - BRIDGES
1205.13	PAVEMENT MARKINGS - LANE REDUCTIONS
1250.01	RAISED PAVEMENT MARKERS - INSTALLATION SPACING
1251.01	RAISED PAVEMENT MARKERS - PERMANENT AND TEMPORARY
1253.01	RAISED PAVEMENT MARKERS - SNOWPLOWABLE
1261.01	GUARDRAIL AND BARRIER DELINEATORS - INSTALLATION SPACING
1261.02	GUARDRAIL AND BARRIER DELINEATORS - TYPES AND MOUNTING
1262.01	GUARDRAIL END DELINEATION
1267.01	FLEXIBLE DELINEATORS - INSTALLATION
1267.02	FLEXIBLE DELINEATORS - SPACING TABLES
1267.03	FLEXIBLE DELINEATORS - INTERCHANGE PLACEMENT

**GENERAL NOTES**

THE FOLLOWING GENERAL NOTES APPLY AT ALL TIMES FOR THE DURATION OF THE CONSTRUCTION PROJECT, EXCEPT WHEN OTHERWISE NOTED IN THE PLAN, OR DIRECTED BY THE ENGINEER.

- A) INSTALL PAVEMENT MARKINGS AND PAVEMENT MARKERS ON THE FINAL SURFACE AS FOLLOWS:
 

ROAD NAME	MARKING	MARKER
ALL ROADS	THERMOPLASTIC	SNOWPLOWABLE
CONCRETE BRIDGE DECKS	COLD APPLIED PLASTIC	RAISED
- B) TIE PROPOSED PAVEMENT MARKING LINES TO EXISTING PAVEMENT MARKING LINES.
- C) REMOVE/REPLACE ANY CONFLICTING/DAMAGED PAVEMENT MARKINGS AND MARKERS.
- D) PASSING ZONES WILL BE DETERMINED IN THE FIELD AND MUST BE APPROVED BY THE ENGINEER.
- E) REMOVE ALL RESIDUE AND SURFACE LAITANCE BY ACCEPTABLE METHODS ON CONCRETE BRIDGE DECKS PRIOR TO PLACING COLD APPLIED PLASTIC PAVEMENT MARKING MATERIAL.
- F) UNLESS OTHERWISE SPECIFIED, HEATED-IN-PLACE THERMOPLASTIC MAY BE USED IN LIEU OF EXTRUDED THERMOPLASTIC FOR STOP BARS, SYMBOLS, CHARACTERS AND DIAGONALS. IF HEATED-IN-PLACE IS USED, IT SHALL BE PAID FOR USING THE EXTRUDED THERMOPLASTIC PAY ITEM.

**INDEX**

SHEET NO.	DESCRIPTION
PMP-1	PAVEMENT MARKING PLAN TITLE
PMP-1A	PAVEMENT MARKING SCHEDULE
PMP-2-15	PAVEMENT MARKING DETAIL

PLAN PREPARED FOR: N.C.D.O.T. SIGNING AND DELINEATION UNIT

Ayman Alqudwah, PE SIGNING & DELINEATION REGIONAL ENGINEER  
Matthew Tracey, PE SIGNING & DELINEATION PROJECT DESIGN ENGINEER/TECHNICIAN

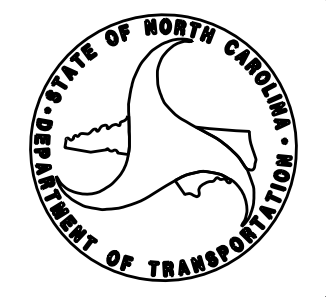

PLAN PREPARED BY: HNTB NORTH CAROLINA, P.C.

A.D. Klinksieck, PE, PTOE PROJECT ENGINEER  
J.A. Wagner, PE DESIGN ENGINEER

**HNTB** HNTB NORTH CAROLINA, P.C.  
 343 E. Six Forks Road, Suite 200  
 Raleigh, North Carolina 27609  
 NC License No: C-1554  
 (919) 546-8997

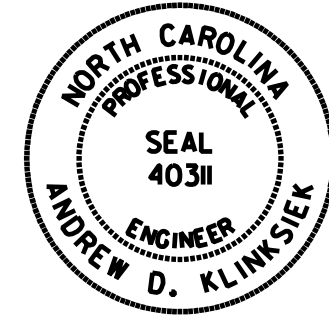
TIP NO. R-3421A	SHEET NO. PMP-1A
APPROVED: <i>Andrew D. Klinck</i> <small>ES078F8498E44B</small>	
DATE: 7/5/2019	
	
DOCUMENT NOT CONSIDERED FINAL UNLESS ALL SIGNATURES COMPLETED	

## FINAL PAVEMENT MARKING SCHEDULE

MATERIAL	SYMBOL	DESCRIPTION
<b>PAVEMENT MARKING</b>		
<u>COLD APPLIED PLASTIC, TYPE II (6")</u>		
	C6	WHITE EDGELINE
	C7	YELLOW EDGELINE
	CJ	10 FT. WHITE SKIP
	CK	3 FT.-9 FT./SP WHITE MINISKIP
<u>THERMOPLASTIC (6", 90 MILS)</u>		
	T6	WHITE EDGELINE
	T7	YELLOW EDGELINE
	T11	2 FT.-6 FT./SP WHITE MINISKIP
	TJ	10 FT. WHITE SKIP
	TK	3 FT.-9 FT./SP WHITE MINISKIP
	TL	WHITE SOLID LANE LINE
<u>THERMOPLASTIC (12", 90 MILS)</u>		
	T14	3 FT.-9 FT./SP WHITE MINISKIP
	TS	WHITE GORELINE
	TT	WHITE SOLID LANE LINE
<u>THERMOPLASTIC PAVEMENT MARKING SYMBOLS (90 MILS)</u>		
	UA	LEFT TURN ARROW
	UB	RIGHT TURN ARROW
	UC	STRAIGHT ARROW
	UE	COMBO RIGHT/STRAIGHT
	UP	MERGE ARROW
<u>THERMOPLASTIC PAVEMENT MARKING CHARACTER (90 MILS)</u>		
	UI	ALPHANUMERIC CHAR.
<u>RAISED PAVEMENT MARKERS (NOT SHOWN)</u>		
	MB	CRYSTAL & RED
<u>SNOWPLOWABLE PAVEMENT MARKERS (NOT SHOWN)</u>		
	MF	CRYSTAL & RED

### LEGEND

- GENERAL**
- DIRECTION OF TRAFFIC FLOW
  - NORTH ARROW
  - PROPOSED PVMT.    EXIST. PVMT.

- PAVEMENT MARKINGS**
- PAVEMENT MARKING SYMBOLS
  - ONLY PAVEMENT MARKING CHARACTERS

**PAVEMENT MARKING SYMBOLS**

	UA		UP
	UB	ONLY	UI
	UC		UE

5/24/13 5:44:33 PM 121... 5/24/13 5:44:33 PM 121... 5/24/13 5:44:33 PM 121...

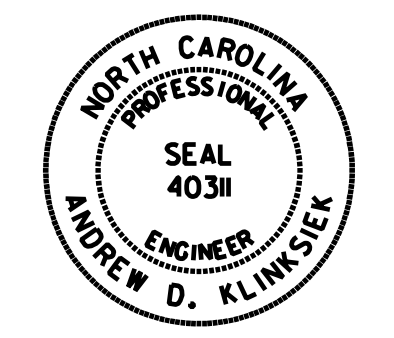
TIP NO. R-3421A	SHEET NO. PMP-2
APPROVED: <i>Andrew D. Klinck</i> <small>E3078FB4986E44B...</small>	
DATE: 7/5/2019	
SEAL	
	
DOCUMENT NOT CONSIDERED FINAL UNLESS ALL SIGNATURES COMPLETED	

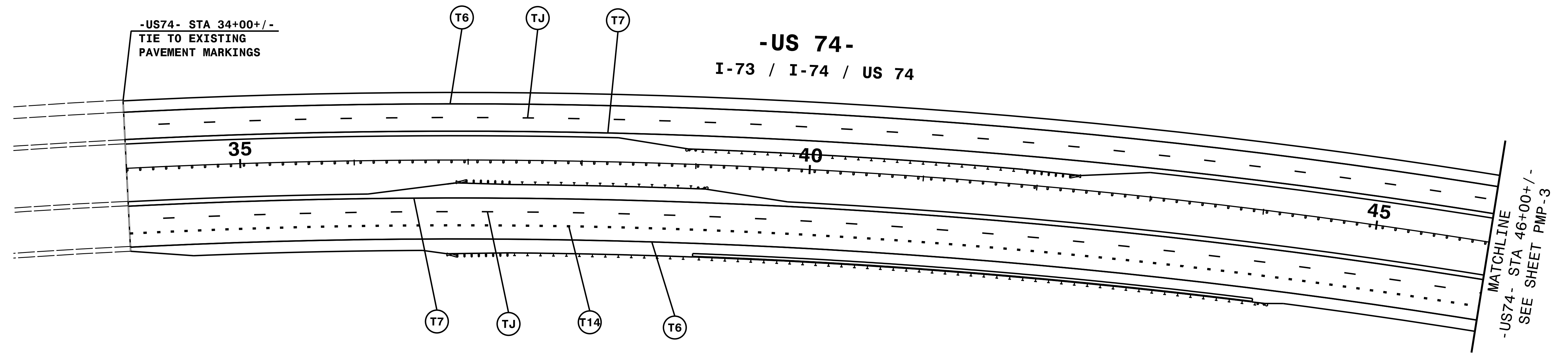
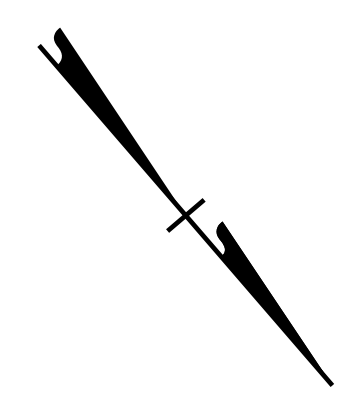

NOTE: ALL LANE WIDTHS ARE 12' UNLESS OTHERWISE SHOWN.

**HNTB** HNTB NORTH CAROLINA, P.C.  
 343 E. Six Forks Road, Suite 200  
 Raleigh, North Carolina 27609  
 NC License No: C-1554

**PAVEMENT MARKING DETAIL**

5:44:33 PM 7/21/19  
 USER: RMALE  
 FILE: pmp02.dgn

TIP NO. R-3421A	SHEET NO. PMP-3
APPROVED: <i>Andrew D. Klinck</i> <small>ES078F8A98E44B</small>	
DATE: 7/5/2019	
SEAL	
	
DOCUMENT NOT CONSIDERED FINAL UNLESS ALL SIGNATURES COMPLETED	

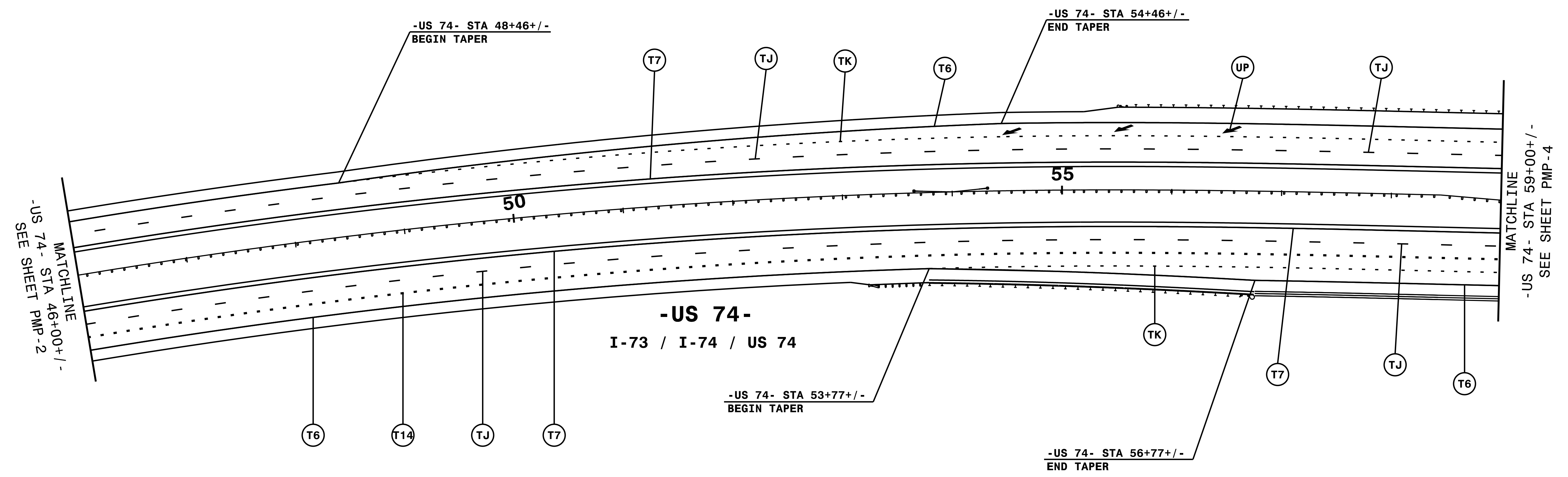
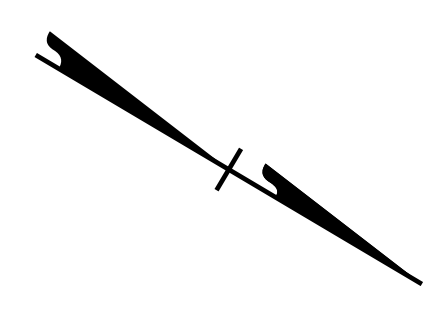

NOTE: ALL LANE WIDTHS ARE 12' UNLESS OTHERWISE SHOWN.

**HNTB** HNTB NORTH CAROLINA, P.C.  
343 E. Six Forks Road, Suite 200  
Raleigh, North Carolina 27609  
NC License No: C-1554

**PAVEMENT MARKING DETAIL**

5:44:14 PM 7/21/2019 \$\$\$\$USERNAME\$\$\$\$ pmp03.dgn

TIP NO. R-3421A	SHEET NO. PMP-4
APPROVED: <i>Andrew D. Klinck</i> <small>E0378FB498E44B</small>	
DATE: 7/5/2019	
	
DOCUMENT NOT CONSIDERED FINAL UNLESS ALL SIGNATURES COMPLETED	

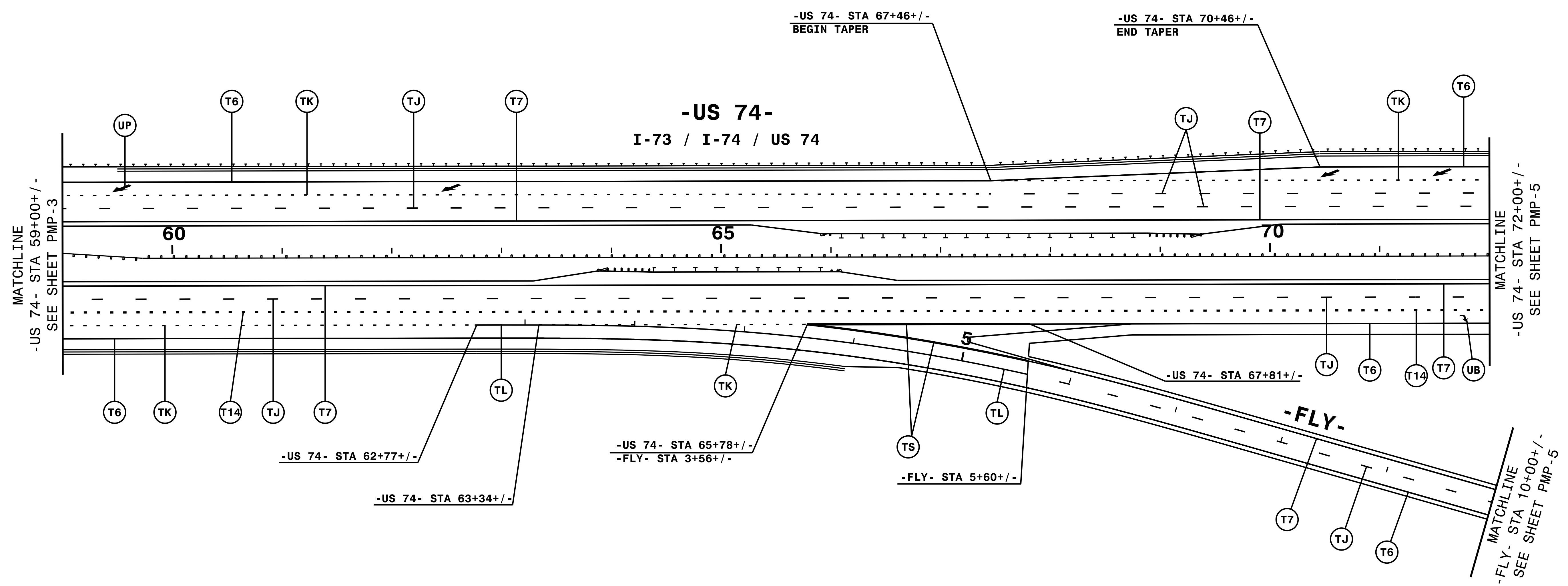

NOTE: ALL LANE WIDTHS ARE 12' UNLESS OTHERWISE SHOWN.

**HNTB** HNTB NORTH CAROLINA, P.C.  
343 E. Six Forks Road, Suite 200  
Raleigh, North Carolina 27609  
NC License No: C-1554

# PAVEMENT MARKING DETAIL

5:44:05 PM 7/21/2019  
USER: NAME \$\$\$\$  
PMP04.dgn

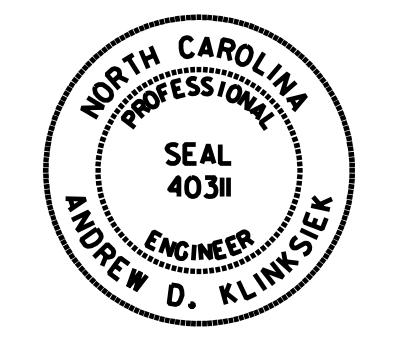
TIP NO. R-3421A	SHEET NO. PMP-5
APPROVED: <i>Andrew D. Klinck</i> <small>ES078F8496E44B</small>	
DATE: 7/5/2019	
	
DOCUMENT NOT CONSIDERED FINAL UNLESS ALL SIGNATURES COMPLETED	

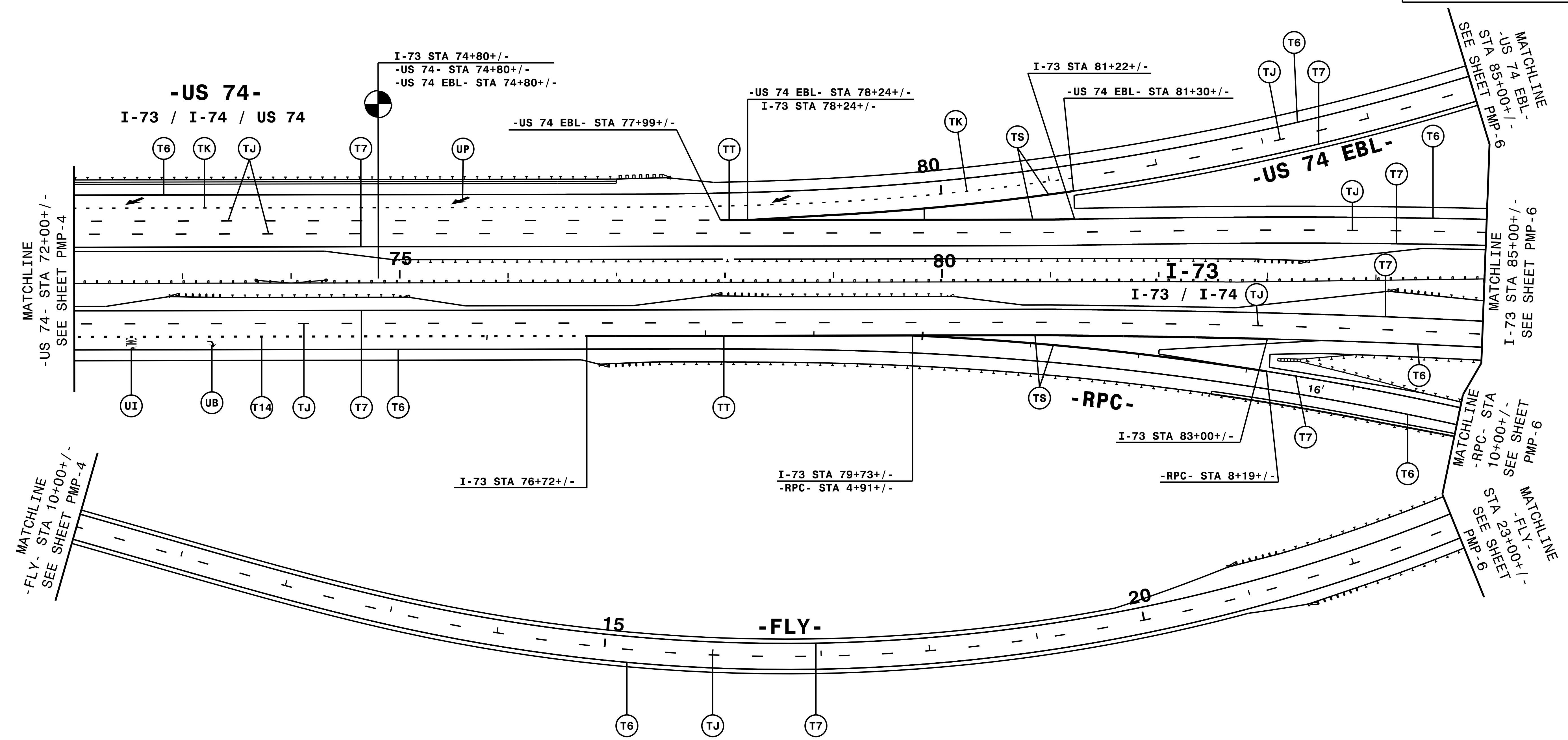

NOTE: ALL LANE WIDTHS ARE 12' UNLESS OTHERWISE SHOWN.

**HNTB** HNTB NORTH CAROLINA, P.C.  
343 E. Six Forks Road, Suite 200  
Raleigh, North Carolina 27609  
NC License No: C-1554

# PAVEMENT MARKING DETAIL

5:44:55 PM 7/21/19  
USER:NAME  
PMP05.dgn

TIP NO. R-3421A	SHEET NO. PMP-6
APPROVED: <i>Andrew D. Klinck</i> <small>ES078FB498E4AB</small>	
DATE: 7/5/2019	
SEAL 	
DOCUMENT NOT CONSIDERED FINAL UNLESS ALL SIGNATURES COMPLETED	

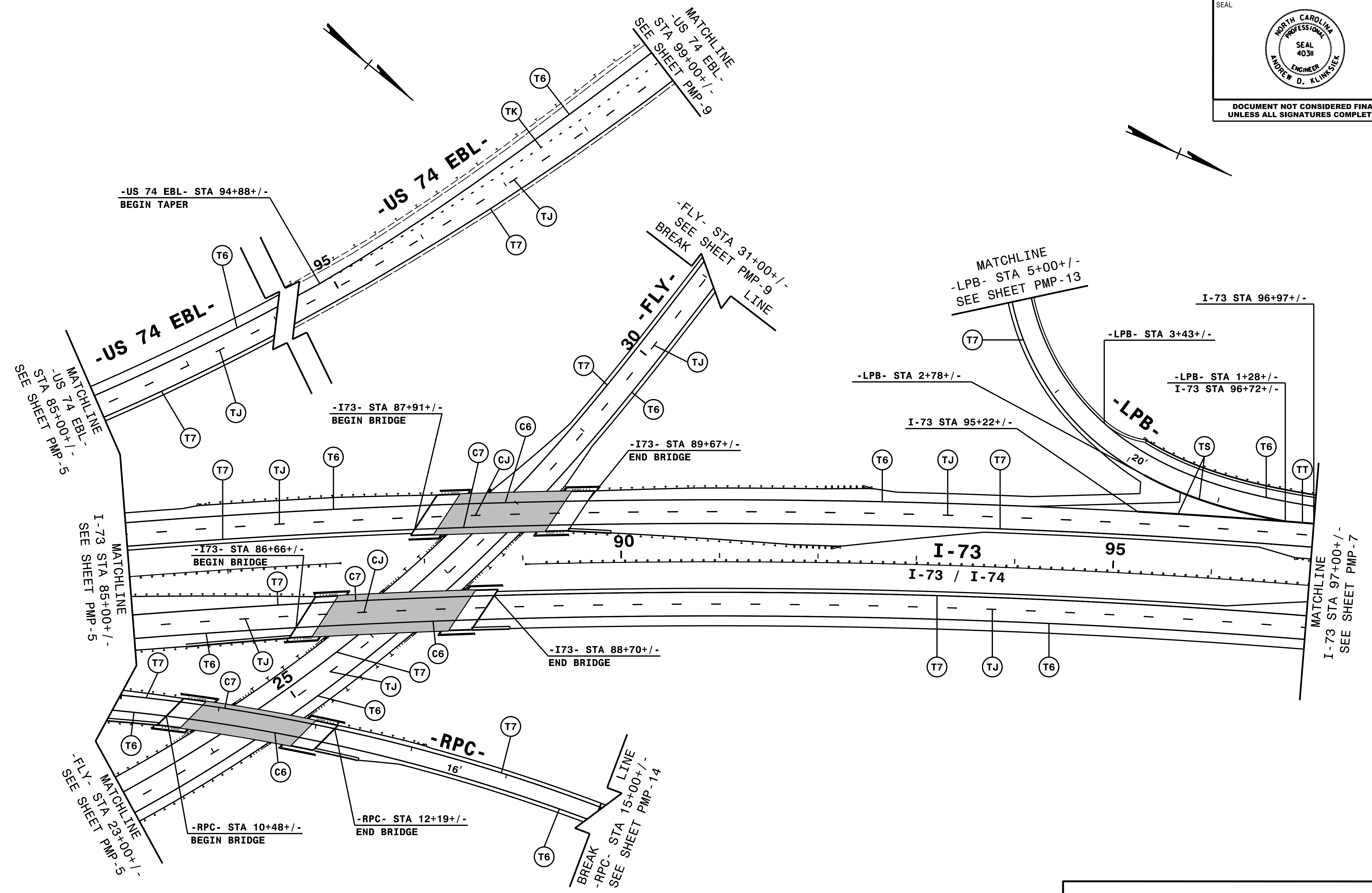

NOTE: ALL LANE WIDTHS ARE 12' UNLESS OTHERWISE SHOWN.

**HNTB** HNTB NORTH CAROLINA, P.C.  
343 E. Six Forks Road, Suite 200  
Raleigh, North Carolina 27609  
NC License No: C-1554

### PAVEMENT MARKING DETAIL

5:44:56 PM 7/21/2019  
C:\Users\ADMINI~1\AppData\Local\Temp\pmp06.dgn

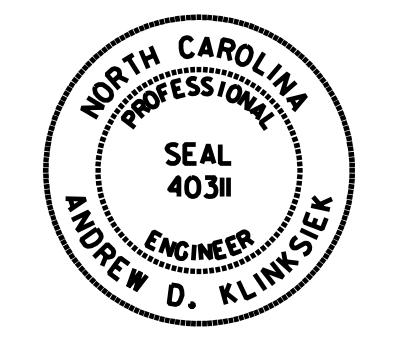
TIP NO. R-3421A	SHEET NO. PMP-7
APPROVED: <i>Andrew D. Klinck</i> <small>ES078F8498E44B</small>	
DATE: 7/5/2019	
SEAL	
	
DOCUMENT NOT CONSIDERED FINAL UNLESS ALL SIGNATURES COMPLETED	

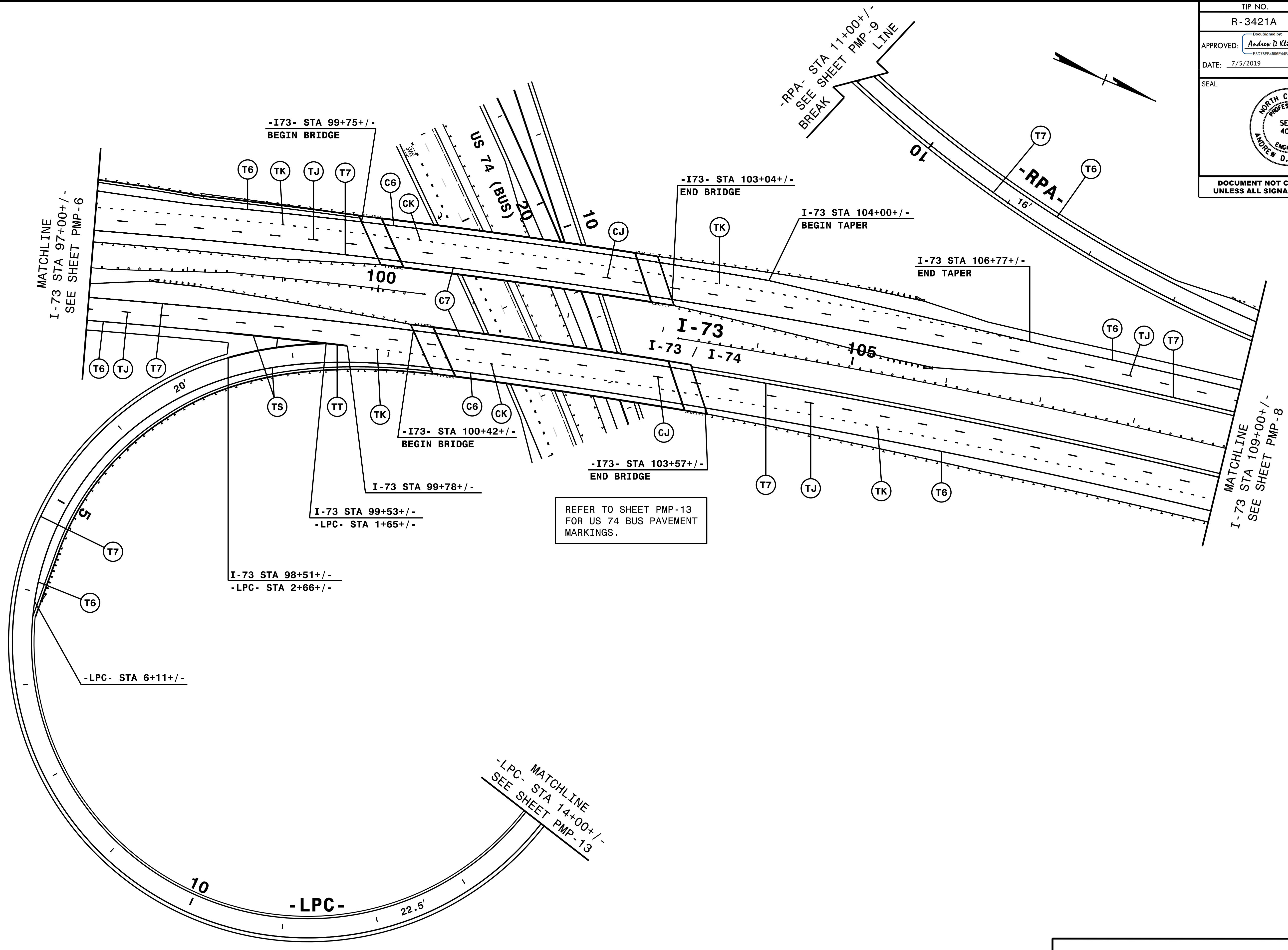

NOTE: ALL LANE WIDTHS ARE 12' UNLESS OTHERWISE SHOWN.

**HNTB** HNTB NORTH CAROLINA, P.C.  
343 E. Six Forks Road, Suite 200  
Raleigh, North Carolina 27609  
NC License No: C-1554

# PAVEMENT MARKING DETAIL

5:44:17 PM 7/21/2019  
C:\Users\ADMINI~1\AppData\Local\Temp\pmp07.dgn



TIP NO. R-3421A	SHEET NO. PMP-8
APPROVED: <i>Andrew D. Klinck</i> <small>ES078F8496E44B</small>	
DATE: 7/5/2019	
SEAL 	
DOCUMENT NOT CONSIDERED FINAL UNLESS ALL SIGNATURES COMPLETED	

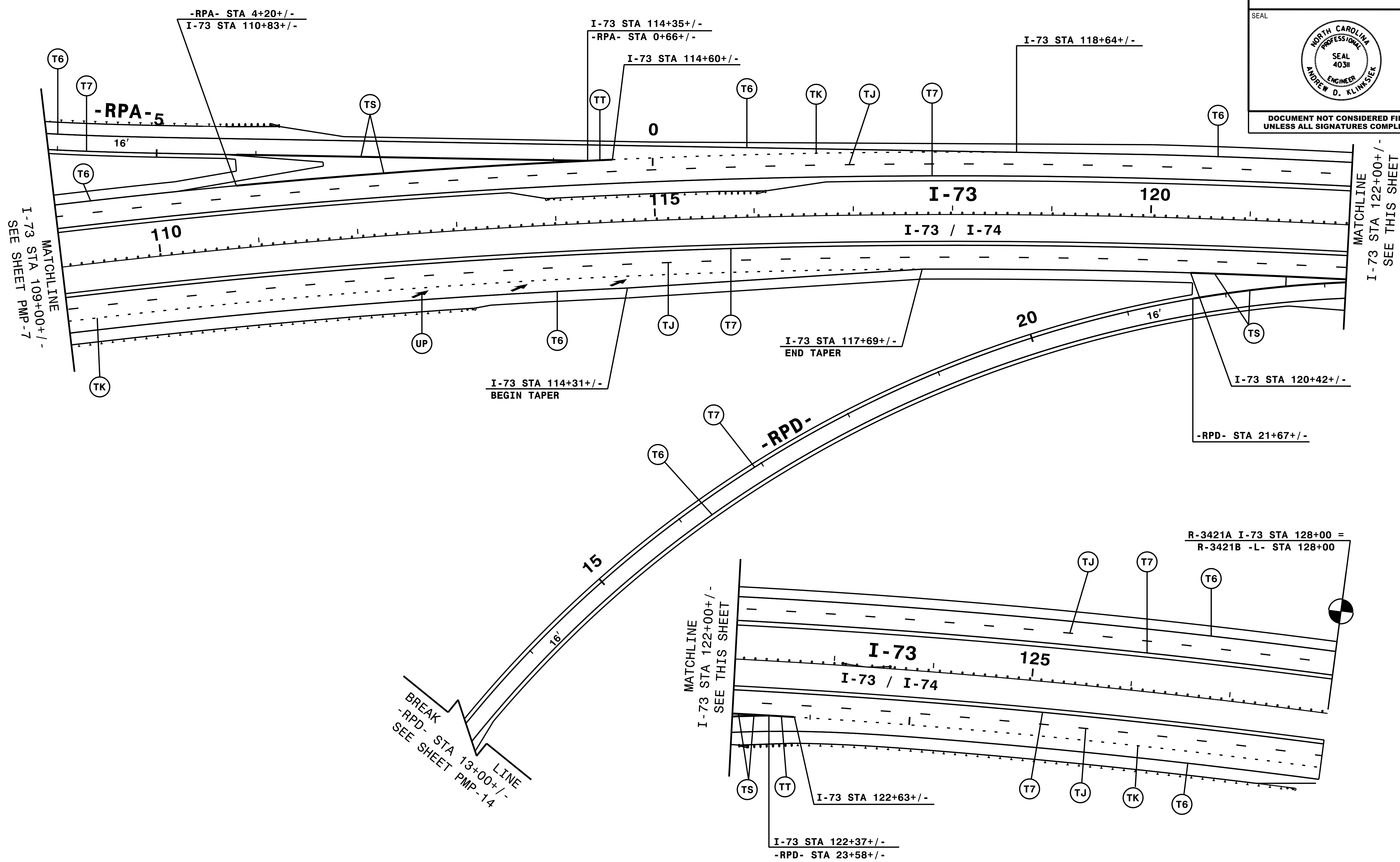

NOTE: ALL LANE WIDTHS ARE 12' UNLESS OTHERWISE SHOWN.

**HNTB** HNTB NORTH CAROLINA, P.C.  
343 E. Six Forks Road, Suite 200  
Raleigh, North Carolina 27609  
NC License No: C-1554

### PAVEMENT MARKING DETAIL

6/16/2019 9:34:21a - pmp - pmp08.dgn  
HNTB

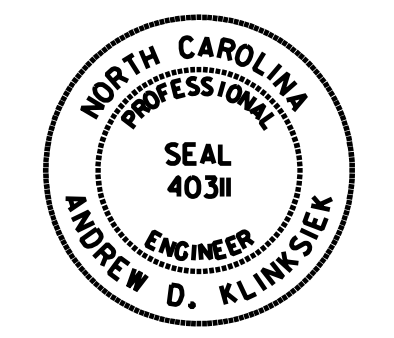
TIP NO. R-3421A	SHEET NO. PMP-9
APPROVED: <i>Andrew D. Klinck</i> <small>E3078FB496E44B...</small>	
DATE: 7/5/2019	
SEAL 	
DOCUMENT NOT CONSIDERED FINAL UNLESS ALL SIGNATURES COMPLETED	

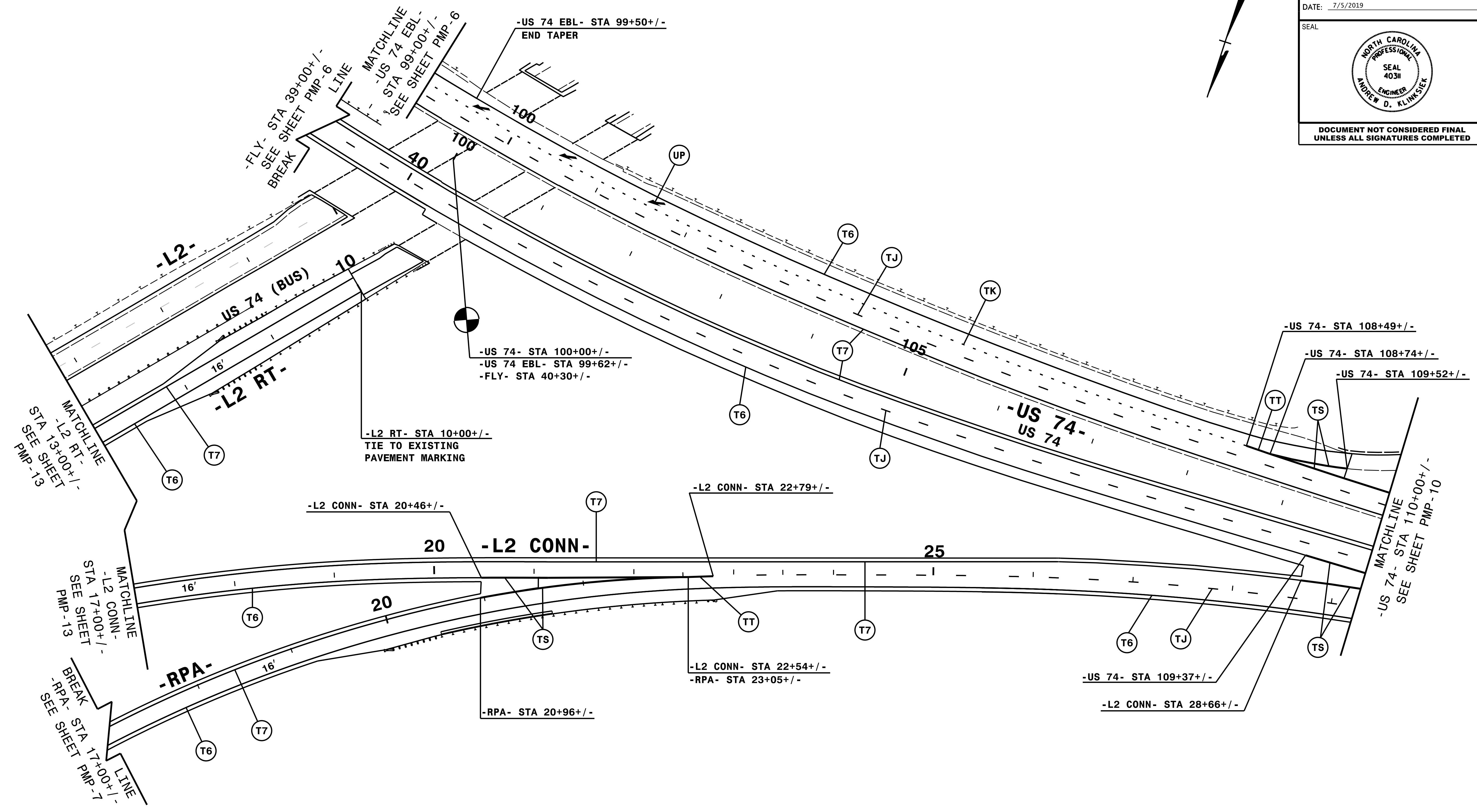

NOTE: ALL LANE WIDTHS ARE 12' UNLESS OTHERWISE SHOWN.

**HNTB** HNTB NORTH CAROLINA, P.C.  
343 E. SIX FORKS ROAD, SUITE 200  
RALEIGH, NORTH CAROLINA 27609  
NC LICENSE NO: C-1554

**PAVEMENT MARKING DETAIL**

6/16/2019 9:34:21a - pmp - pmp09.dgn  
HNTB

TIP NO. R-3421A	SHEET NO. PMP-10
APPROVED: <i>Andrew D. Klinkoski</i> <small>E3078F8459E44B...</small>	
DATE: 7/5/2019	
	
DOCUMENT NOT CONSIDERED FINAL UNLESS ALL SIGNATURES COMPLETED	

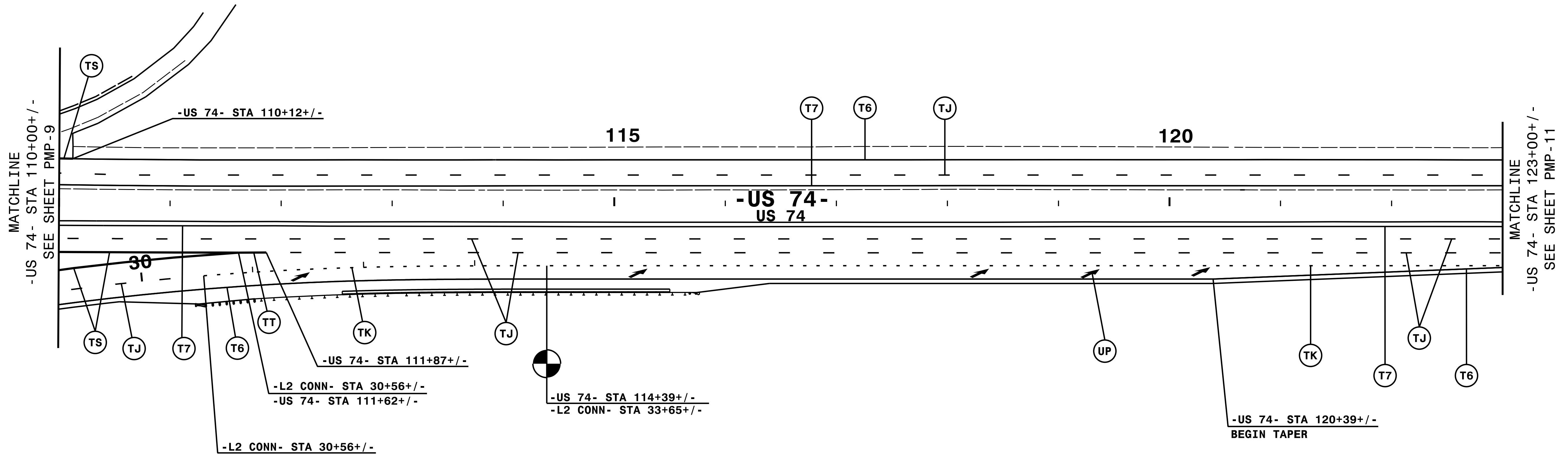

NOTE: ALL LANE WIDTHS ARE 12' UNLESS OTHERWISE SHOWN.

**HNTB** HNTB NORTH CAROLINA, P.C.  
343 E. Six Forks Road, Suite 200  
Raleigh, North Carolina 27609  
NC License No: C-1554

# PAVEMENT MARKING DETAIL

5:44:20 PM 7/21/2019  
\\SUSERS\NAME\3589-pmp10.dgn

TIP NO. R-3421A	SHEET NO. PMP-11
APPROVED: <i>Andrew D. Klinck</i> <small>E3078FB498E44B...</small>	
DATE: 7/5/2019	
	
DOCUMENT NOT CONSIDERED FINAL UNLESS ALL SIGNATURES COMPLETED	

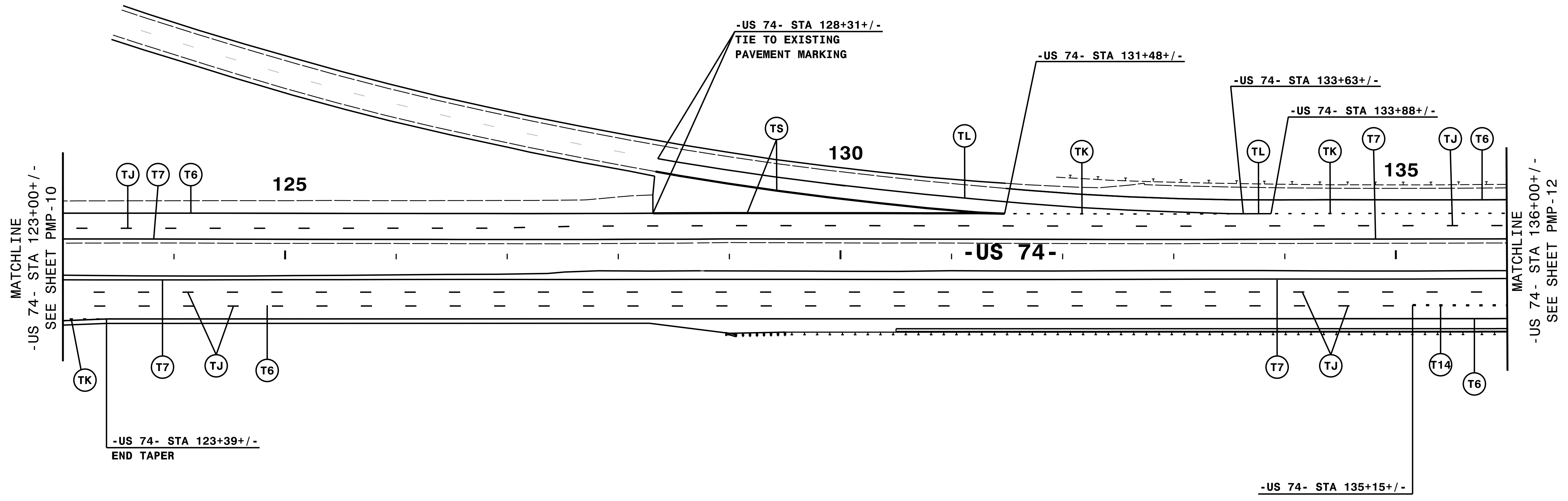

-US 74- STA 123+39+/-  
END TAPER

NOTE: ALL LANE WIDTHS ARE 12' UNLESS OTHERWISE SHOWN.

**HNTB** HNTB NORTH CAROLINA, P.C.  
343 E. Six Forks Road, Suite 200  
Raleigh, North Carolina 27609  
NC License No: C-1554

# PAVEMENT MARKING DETAIL

5:44:20 PM 7/21/19  
USER: ANDREW.D.KLINCK  
PROJECT: R-3421A-PMP-11.dgn

TIP NO. R-3421A	SHEET NO. PMP-12
APPROVED: <i>Andrew D. Klinck</i> <small>ESD78FB498E44B</small>	
DATE: 7/5/2019	
DOCUMENT NOT CONSIDERED FINAL UNLESS ALL SIGNATURES COMPLETED	

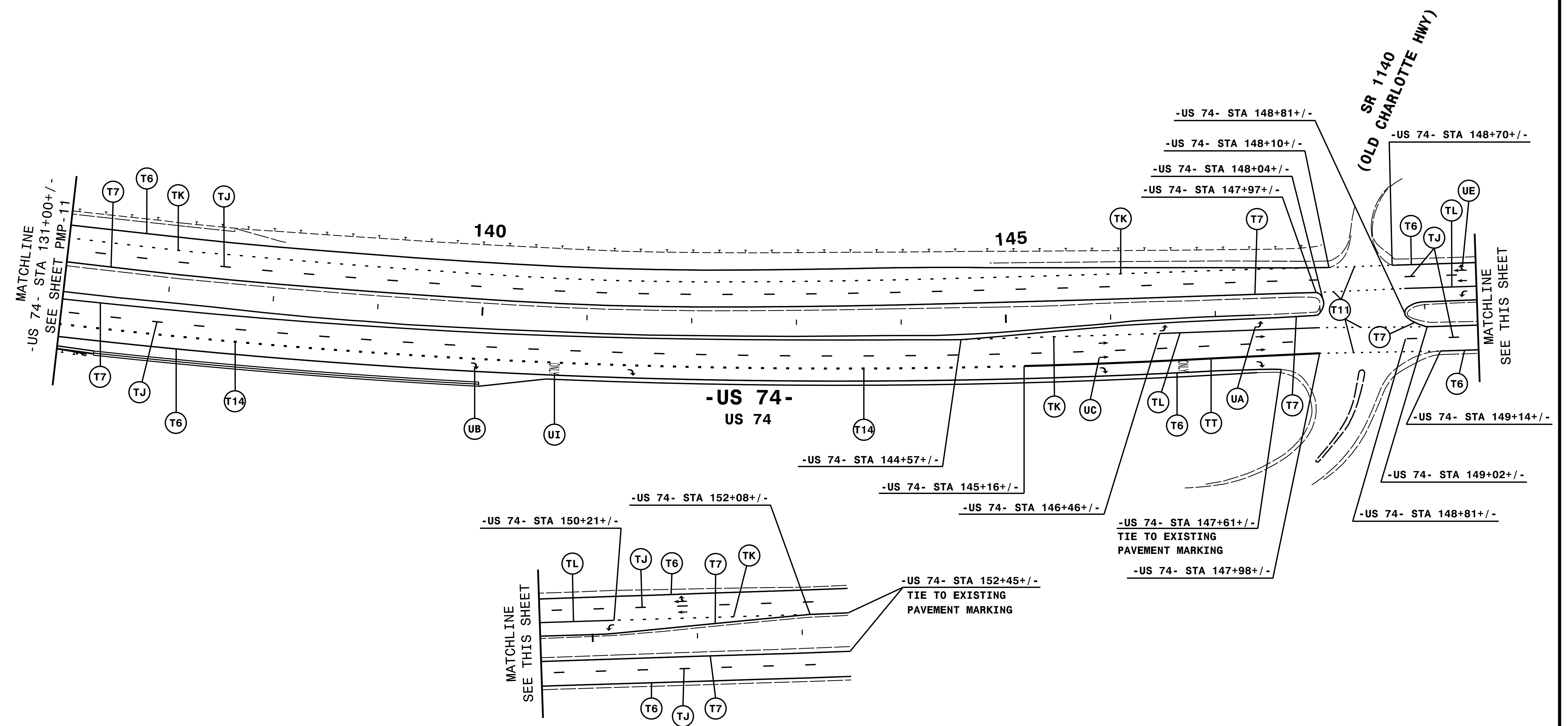

10:29:05 AM 21\_...\_pmp12.dgn  
 \$\$\$USERNAME\$\$\$

NOTE: ALL LANE WIDTHS ARE 12' UNLESS OTHERWISE SHOWN.

**HNTB** HNTB NORTH CAROLINA, P.C.  
 343 E. Six Forks Road, Suite 200  
 Raleigh, North Carolina 27609  
 NC License No: C-1554

**PAVEMENT MARKING DETAIL**

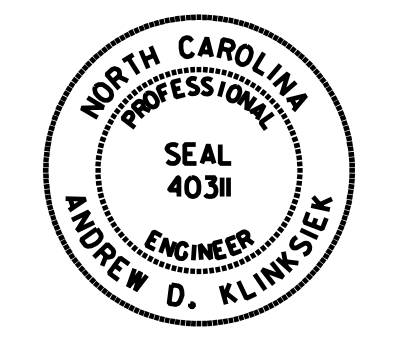

TIP NO. R-3421A	SHEET NO. PMP-14
APPROVED: <i>Andrew D. Klinck</i> <small>ES078F8498648</small>	
DATE: 7/5/2019	
SEAL 	
DOCUMENT NOT CONSIDERED FINAL UNLESS ALL SIGNATURES COMPLETED	

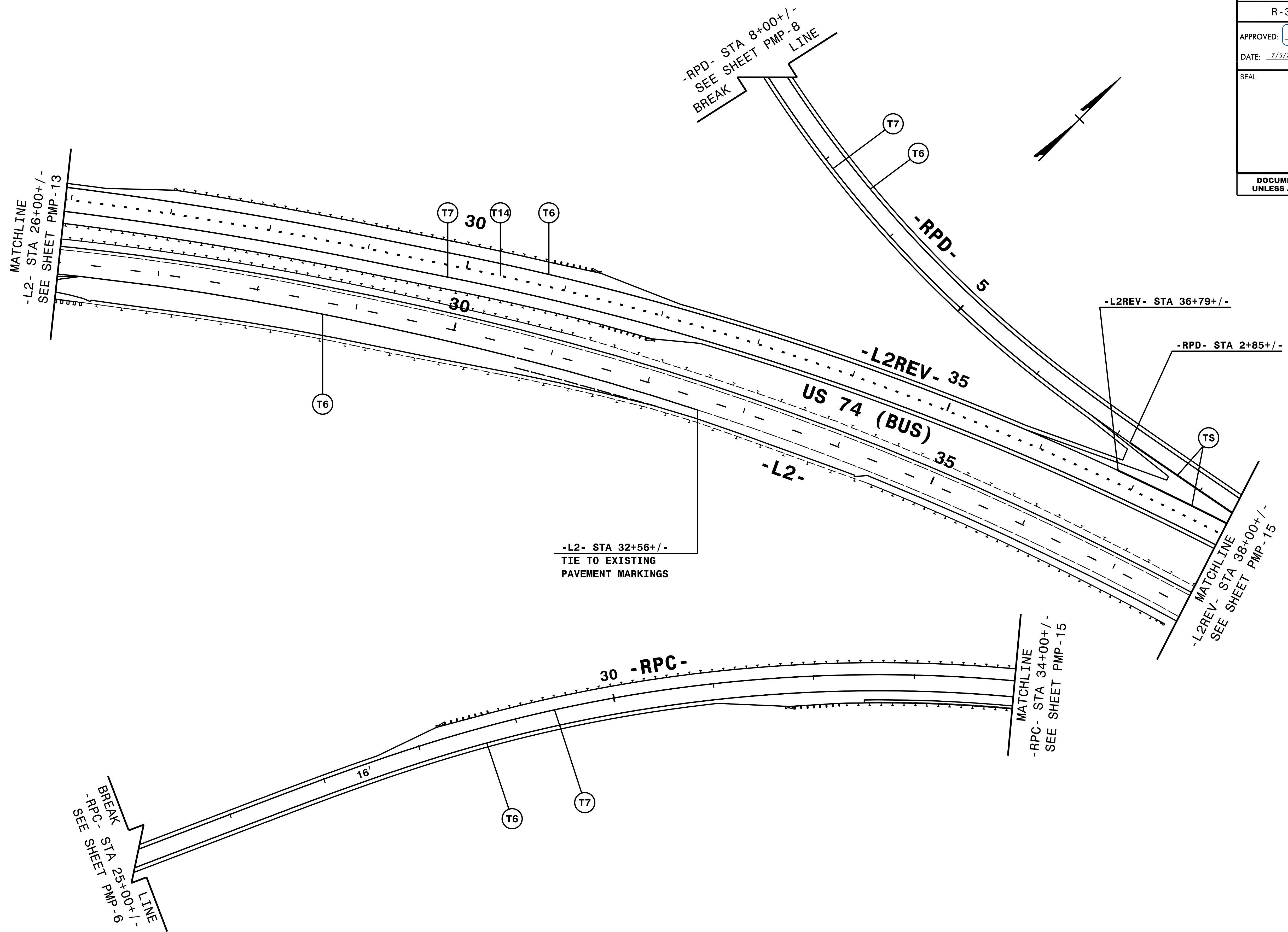

NOTE: ALL LANE WIDTHS ARE 12' UNLESS OTHERWISE SHOWN.

**HNTB** HNTB NORTH CAROLINA, P.C.  
343 E. SIX FORKS ROAD, SUITE 200  
RALEIGH, NORTH CAROLINA 27609  
NC LICENSE NO: C-1554

# PAVEMENT MARKING DETAIL

5:44:23 PM 7/21/2019  
USER: ANDREW.D.KLINCK  
PROJECT: R-3421A-PMP-14.dgn

TIP NO. R-3421A	SHEET NO. PMP-15
APPROVED: <i>Andrew D. Klinck</i> <small>DESIGNED BY: Andrew D. Klinck E3078FB496E44B</small>	
DATE: 7/5/2019	
SEAL 	
DOCUMENT NOT CONSIDERED FINAL UNLESS ALL SIGNATURES COMPLETED	

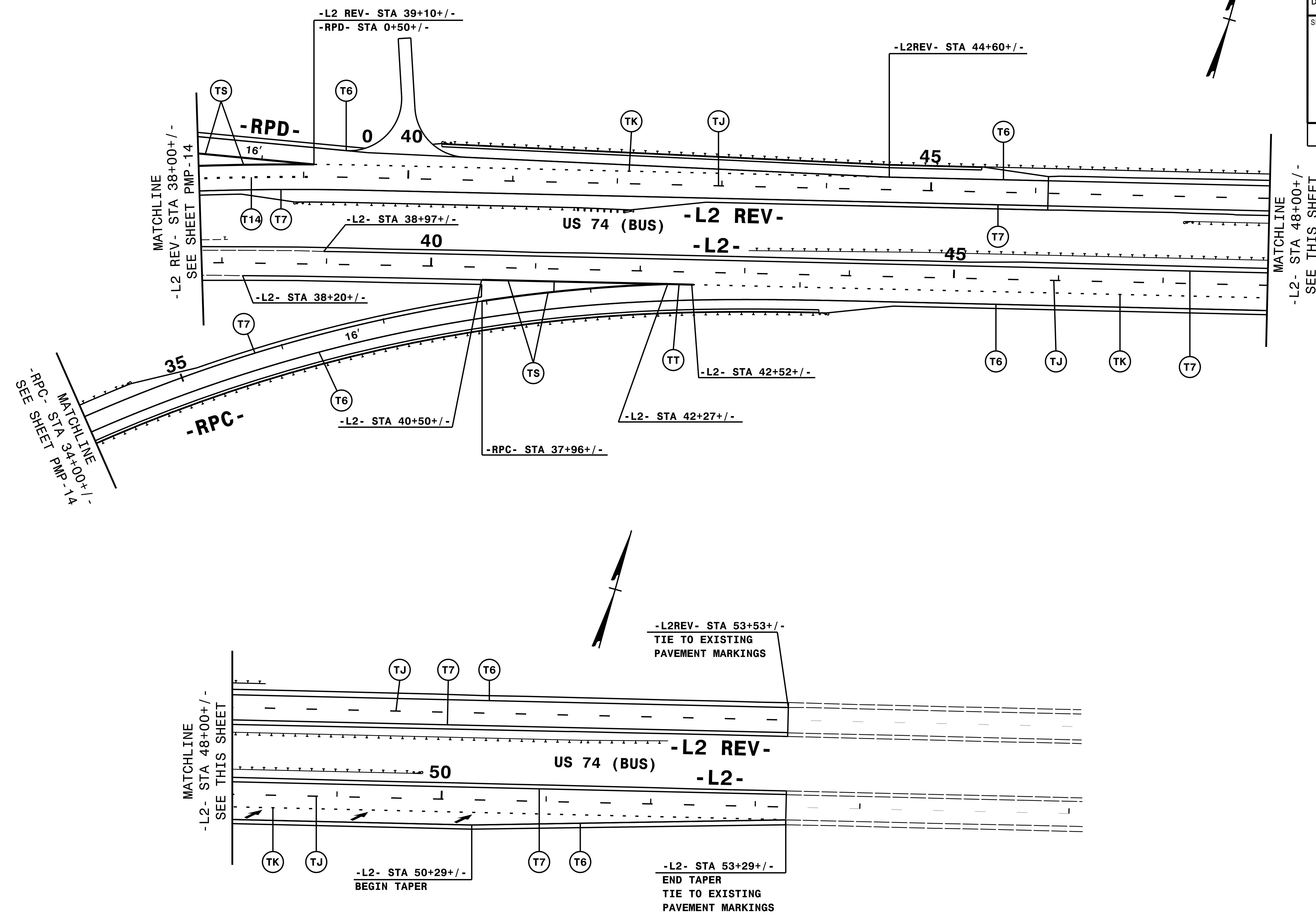

NOTE: ALL LANE WIDTHS ARE 12' UNLESS OTHERWISE SHOWN.

**HNTB** HNTB NORTH CAROLINA, P.C.  
343 E. SIX FORKS ROAD, SUITE 200  
RALEIGH, NORTH CAROLINA 27609  
NC LICENSE NO: C-1554

# PAVEMENT MARKING DETAIL

6/16/2019 9:34:21a.pmp.pmp15.dgn  
HNTB