

PLOT DRIVER: pdfplotter  
USER: KHECTOR  
DATE: 12/12/18  
TIME: 10:15:33  
SCALE: 1:7.99999  
PENTABLE: NCDOT\_Signing.tbl  
FILE: NCDOT\2015.NCDOT\_TMSD.Limited.Ser.Vices.Contract.M.7000016704\NCDOT-R2530B.B4974\_1.T03.c.\6.0.CAD.BTM\6.2.Work.In.Progess\Traffic\Signing\CADD\Signing\_Layout\_Plans\U2530B\_SGN\_Esigns.dgn

REVISIONS

401 QUANTITY REQ'D 36

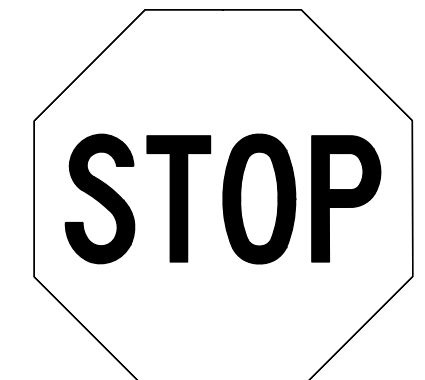

36 X 36  
R1-1

MOUNTED BACK TO BACK WITH SIGN 402 IN 1 INSTALLATION  
MOUNTED UNDER SIGN #409 IN 27 INSTALLATIONS  
ONE "U POST" PER SIGN

406 QUANTITY REQ'D 1



36 X 36  
W1-2L

ONE "U POST"

411 QUANTITY REQ'D 8

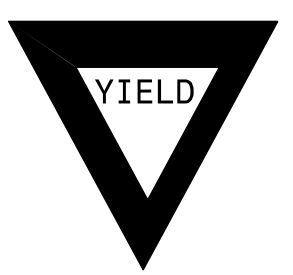

30 X 30 X 30  
R1-2

ONE "U POST" PER SIGN

416 QUANTITY REQ'D 4

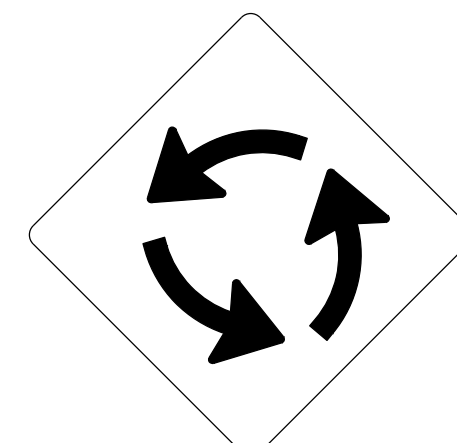

30 X 30  
W2-6

ONE "U POST" PER SIGN

421 QUANTITY REQ'D 24



54 X 18  
R6-1L

MOUNTED BACK TO BACK WITH SIGN 453 IN 3 INSTALLATION  
TWO "U POSTS" PER SIGN

426 QUANTITY REQ'D 2

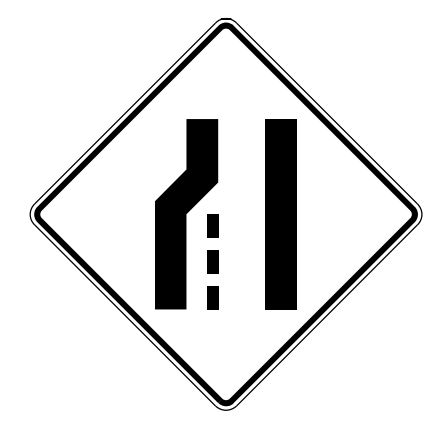

48 X 48  
W4-2L

ONE "U POST" PER SIGN

402 QUANTITY REQ'D 6



36 X 36  
R5-1

MOUNTED BACK TO BACK WITH SIGN 401 IN 1 INSTALLATION  
ONE "U POST" PER SIGN

407 QUANTITY REQ'D 27

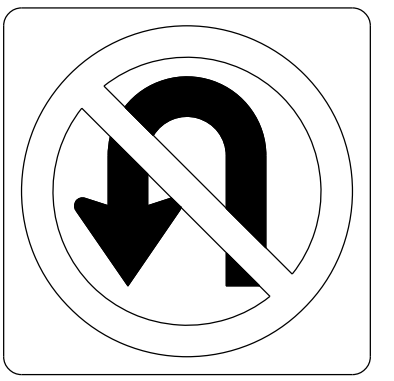

R3-4  
36 X 36

ONE "U POST" PER SIGN

412 QUANTITY REQ'D 9



36 X 36  
W11-2

ONE "U POST" PER SIGN

417 QUANTITY REQ'D 2

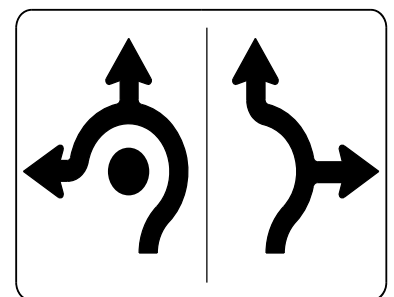

36 X 36  
R3-8RA

ONE "U POST" PER SIGN

422 QUANTITY REQ'D 6

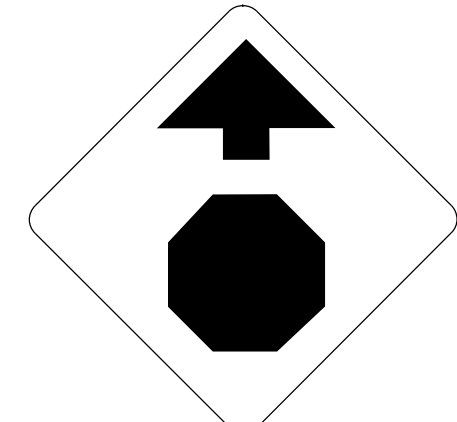

30 X 30  
W3-1

ONE "U POST" PER SIGN

427 QUANTITY REQ'D 1

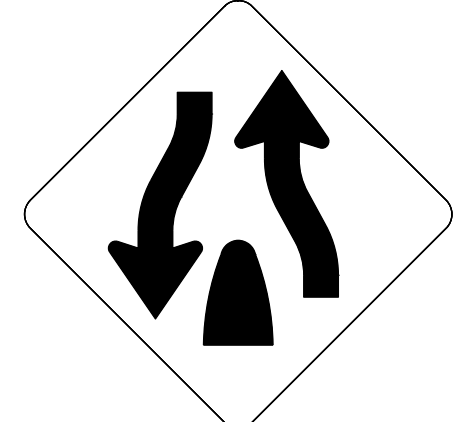

36 X 36  
W6-2

ONE "U POST"

PROJ. REFERENCE NO. <b>R-2530B</b>	SHEET NO. <b>SIGN-4</b>
DOCUMENT NOT CONSIDERED FINAL UNLESS ALL SIGNATURES COMPLETED	
 HDR Engineering, Inc. of the Carolinas 555 Fayetteville St, Suite 900 Raleigh, N.C. 27601 N.C.B.E.L.S. License Number: F-0116	

NOTE:  
THIS DRAWING IS DIMENSIONED IN INCHES UNLESS OTHERWISE DEPICTED WITHIN THE DRAWING.

403 QUANTITY REQ'D 12

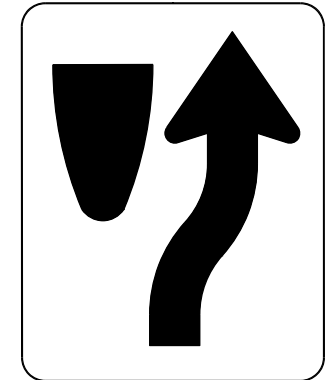

24 X 30  
R4-7

ONE "U POST" PER SIGN

408 QUANTITY REQ'D 1



24 X 30  
R4-1

ONE "U POST" PER SIGN

413 QUANTITY REQ'D 9

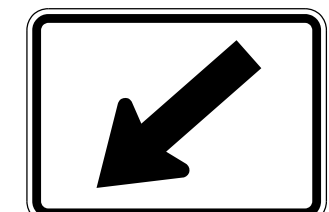

21 X 15  
M6-2A(L)

MOUNTED UNDER SIGN #414 IN 7 INSTALLATIONS

418 QUANTITY REQ'D 2

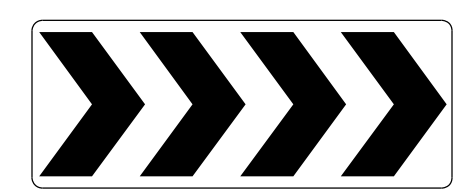

60 X 24  
R6-4B

TWO "U POSTS" PER SIGN

423 QUANTITY REQ'D 1



48 X 48  
W9-1

TWO "U POSTS" PER SIGN

428 QUANTITY REQ'D 1

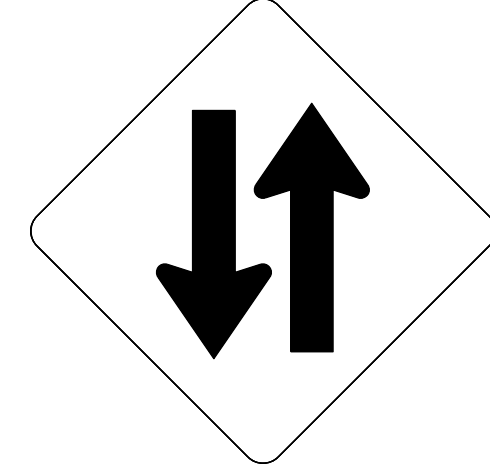

36 X 36  
W6-3

ONE "U POST"

431 QUANTITY REQ'D 1

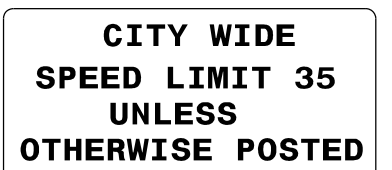

42 X 30  
R2-27

ONE "U POST"

404 QUANTITY REQ'D 12

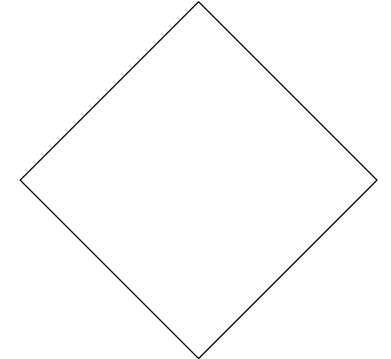

18 X 18  
OM4-3

MOUNTED UNDER SIGN #403 IN 12 INSTALLATIONS

409 QUANTITY REQ'D 27



36 X 12  
R6-1R

MOUNTED TO SIGN #401

414 QUANTITY REQ'D 8

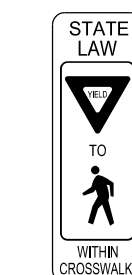

12 X 36  
R1-6B

ONE "U POST" PER SIGN

419 QUANTITY REQ'D 2

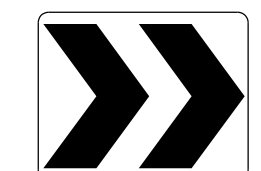

30 X 24  
R6-4

TWO "U POSTS" PER SIGN

424 QUANTITY REQ'D 3

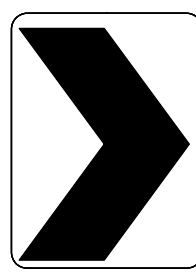

18 X 24  
W1-8R

ONE "U POST" PER SIGN

429 QUANTITY REQ'D 11

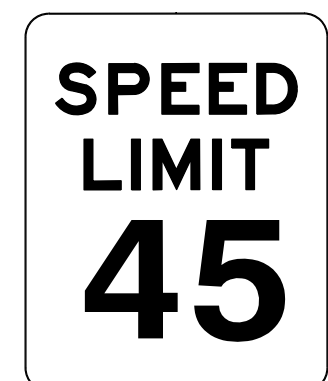

30 X 36  
R2-1

ONE "U POST" PER SIGN

405 QUANTITY REQ'D 1

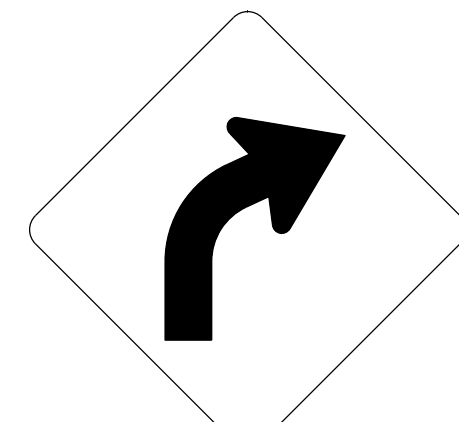

36 X 36  
W1-2R

ONE "U POST"

410 QUANTITY REQ'D 32

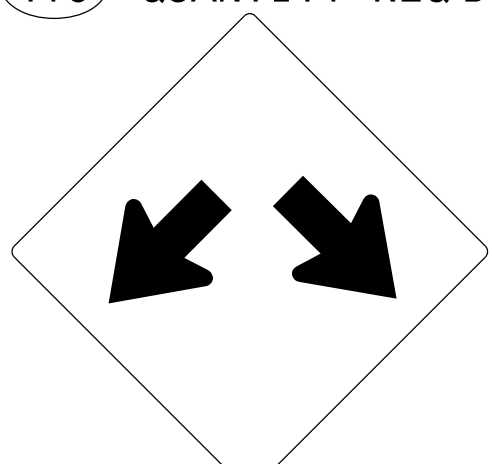

36 X 36  
W12-1

ONE "U POST" PER SIGN

430 QUANTITY REQ'D 15

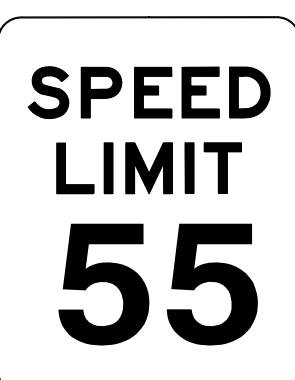

30 X 36  
R2-1

TWO "U POSTS" PER SIGN

420 QUANTITY REQ'D 36



36 X 24  
R5-1a

ONE "U POST" PER SIGN

APPROVED: *Kon King* DATE: 12/13/2018



TYPE "E" SIGNS

SCALE: NTS		REVISIONS
DATE: 12/12/18		
DWG. BY: K HECTOR		
DESIGN BY: K HECTOR		
REVIEWED BY: R KING		CADD FILE