

**This electronic collection of documents is provided  
for the convenience of the user  
and is Not a Certified Document –**

**The documents contained herein were originally issued  
and sealed by the individuals whose names and license  
numbers appear on each page, on the dates appearing  
with their signature on that page.**

**This file or an individual page  
shall not be considered a certified document.**

STATE OF NORTH CAROLINA  
DIVISION OF HIGHWAYS

**TRANSPORTATION MANAGEMENT PLAN**

**GREENE COUNTY**

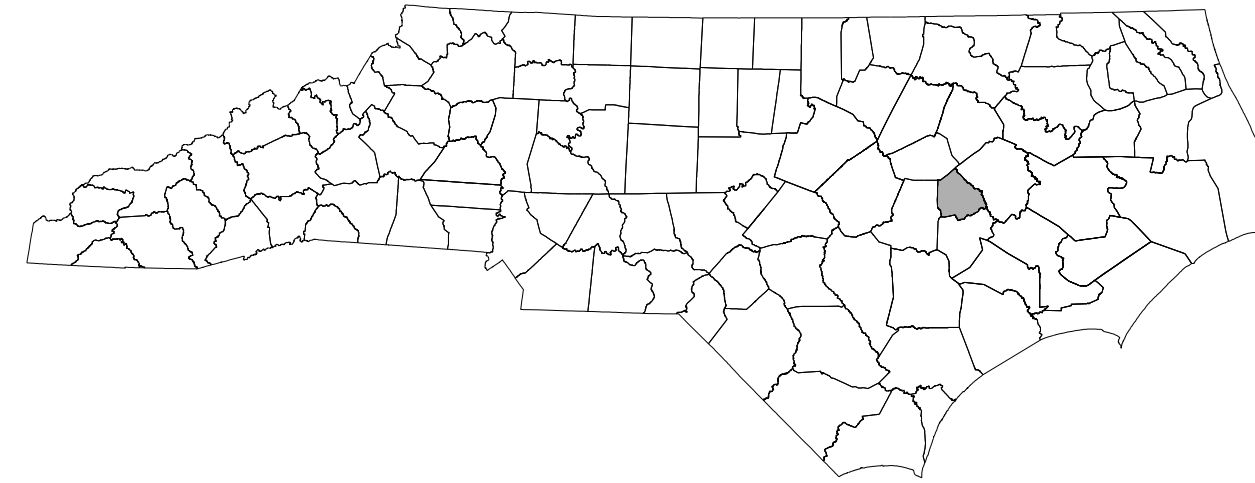

**LOCATION: US 13 FROM NC 58 (KINGOLD BLVD) TO NC 91**

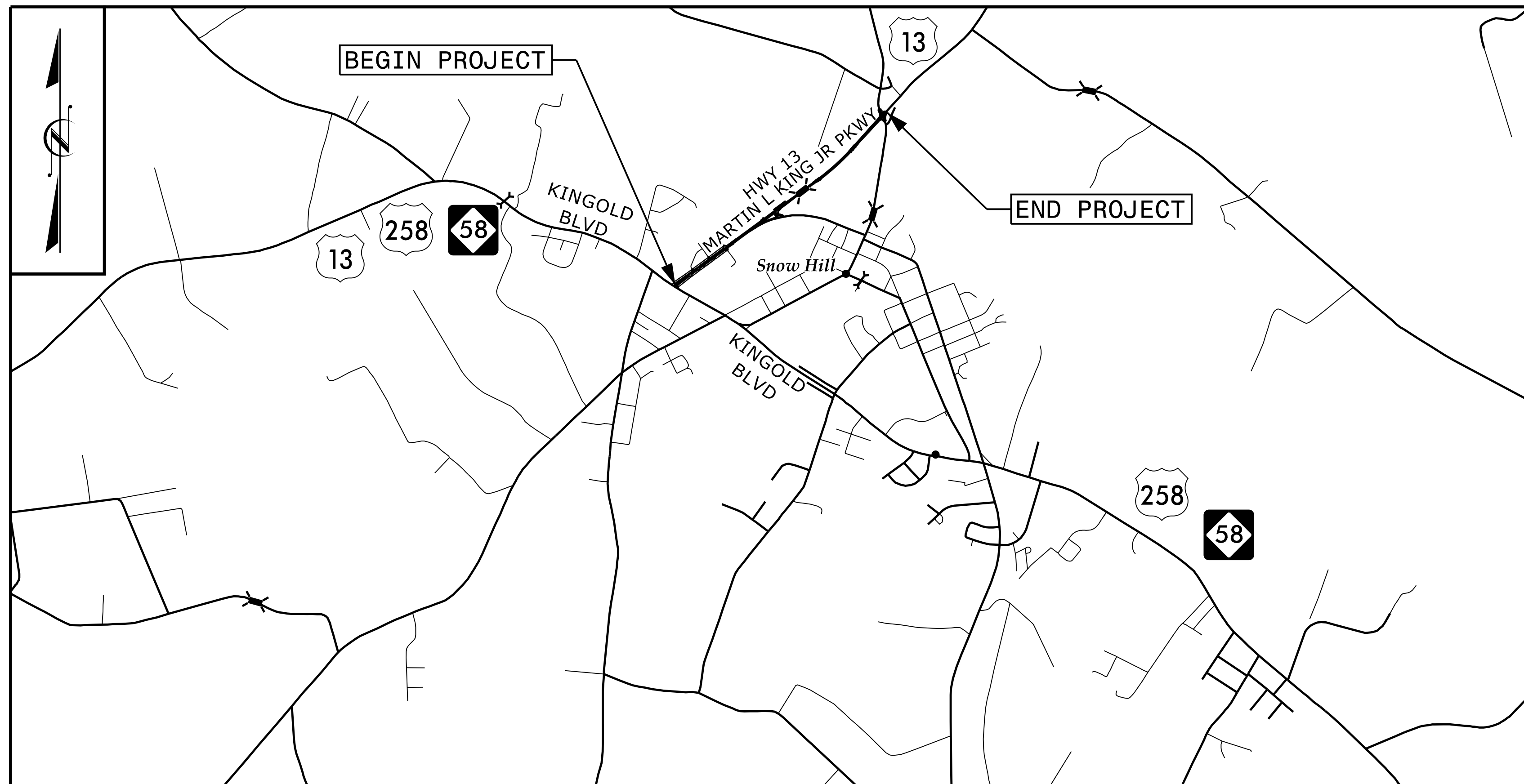

<u>SHEET NO.</u>	<u>TITLE</u>
TMP-1	TITLE SHEET, VICINITY MAP, AND INDEX OF SHEETS
TMP-1A	LIST OF APPLICABLE ROADWAY STANDARD DRAWINGS, AND LEGEND
TMP-2 & TMP-2A	TRANSPORTATION OPERATIONS PLAN: (MANAGEMENT STRATEGIES AND GENERAL NOTES)
TMP-3	TEMPORARY TRAFFIC CONTROL PHASING
TMP-4 THRU TMP-8	TEMPORARY TRAFFIC CONTROL PHASE 1 DETAILS
TMP-9 THRU TMP-16	TEMPORARY TRAFFIC CONTROL PHASE 2 DETAILS

SHEET NO.

TMP-1

**R-5812**

PLOT DRIVER: NCDOT\_pdf\_color\_eng\_50.plt  
 USER: DWAINWRI  
 FILE: p:\p\h\users\DWAINWRI\US\_East\_01\Documents\3322\10001377\10082845\6.0\_CAD\_BIM\6.2\_Work\In\_Progress\R-5812\TrafficControl\TCP\RS812.TC\_TMP-01.dgn  
 PENTABLE: NCDOT\_tcp.tbl  
 DATE: 6/18/2019  
 TIME: 3:30:58 PM

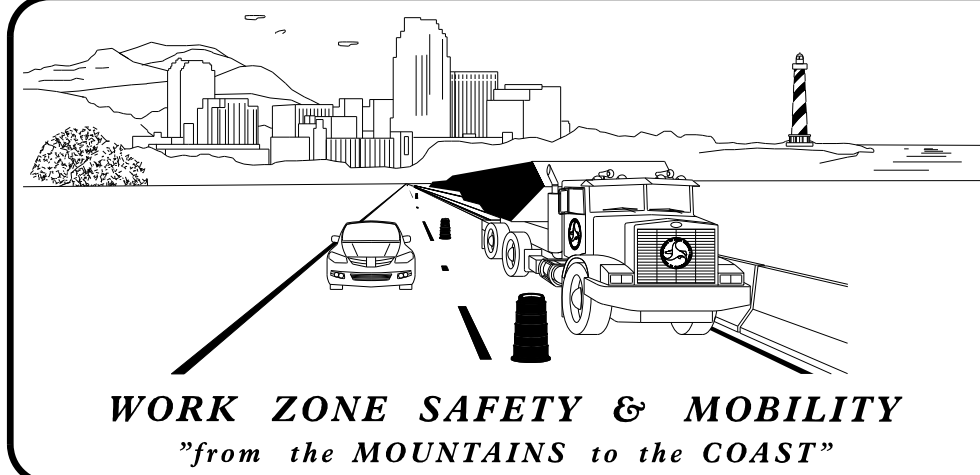

**PLANS PREPARED BY:**

MICHELLE WARD, P.E.  
TRAFFIC CONTROL PROJECT ENGINEER

BRANDON SCOTT  
TRAFFIC CONTROL DESIGN ENGINEER

**NCDOT CONTACTS:**

STEVE KITE, P.E.  
PROJECT ENGINEER

SPENCER JENNINGS  
PROJECT DESIGN ENGINEER



PLAN PREPARED BY:  
**HDR** HDR Engineering, Inc. of the Carolinas  
555 Fayetteville St, Suite 900 Raleigh, N.C. 27601  
N.C.B.E.L.S. License Number: F-0116

**DOCUMENT NOT CONSIDERED FINAL  
UNLESS ALL SIGNATURES COMPLETED**

APPROVED: *Michelle Ward*

DATE: 6/18/2019

SEAL

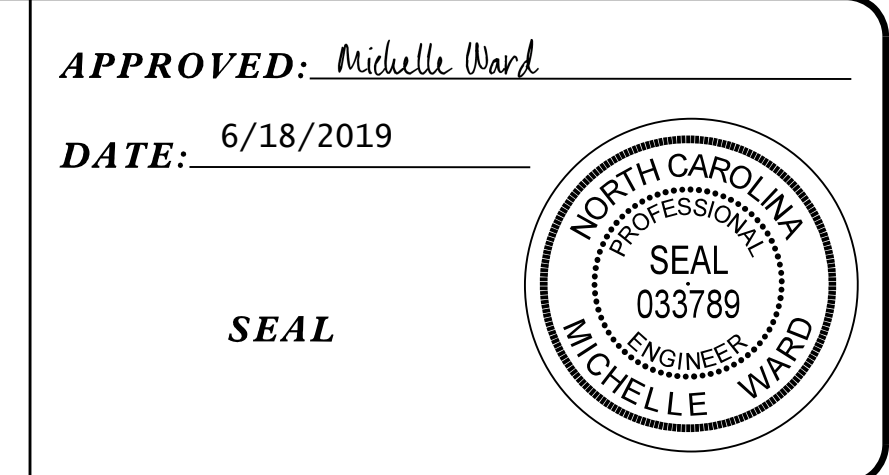

**TIP PROJECT:**

# ROADWAY STANDARD DRAWINGS

THE FOLLOWING ROADWAY STANDARDS AS SHOWN IN "ROADWAY STANDARD DRAWINGS" - N.C. DEPARTMENT OF TRANSPORTATION - RALEIGH, N.C., DATED JANUARY 2018 ARE APPLICABLE TO THIS PROJECT AND BY REFERENCE HEREBY ARE CONSIDERED A PART OF THESE PLANS:

STD. NO.	TITLE
1101.01	WORK ZONE ADVANCE WARNING SIGNS
1101.02	TEMPORARY LANE CLOSURES
1101.03	TEMPORARY ROAD CLOSURES
1101.04	TEMPORARY SHOULDER CLOSURES
1101.05	WORK ZONE VEHICLE ACCESSES
1101.11	TRAFFIC CONTROL DESIGN TABLES
1110.01	STATIONARY WORK ZONE SIGNS
1110.02	PORTABLE WORK ZONE SIGNS
1115.01	FLASHING ARROW BOARDS
1130.01	DRUM
1135.01	CONES
1145.01	BARRICADES
1150.01	FLAGGING DEVICES
1160.01	TEMPORARY CRASH CUSHION
1165.01	WORK VEHICLE LIGHTING SYSTEMS AND TMA DELINEATION
1170.01	POSITIVE PROTECTION
1180.01	SKINNY-DRUM
1205.01	PAVEMENT MARKINGS - LINE TYPES AND OFFSETS
1205.02	PAVEMENT MARKINGS - TWO-LANE AND MULTI-LANE ROADWAYS
1205.03	PAVEMENT MARKINGS - EXITS AND ENTRANCE RAMP
1205.04	PAVEMENT MARKINGS - INTERSECTIONS
1205.05	PAVEMENT MARKINGS - TURN LANES
1205.08	PAVEMENT MARKINGS - SYMBOLS AND WORD MESSAGES
1205.09	PAVEMENT MARKINGS - PAINTED ISLANDS
1205.12	PAVEMENT MARKINGS - BRIDGES
1250.01	RAISED PAVEMENT MARKERS - INSTALLATION SPACING
1251.01	RAISED PAVEMENT MARKERS - PERMANENT AND TEMPORARY
1261.01	GUARDRAIL AND BARRIER DELINEATORS - INSTALLATION SPACING
1261.02	GUARDRAIL AND BARRIER DELINEATORS - TYPES AND MOUNTING
1262.01	GUARDRAIL END DELINEATION

# LEGEND

## GENERAL

- DIRECTION OF TRAFFIC FLOW
- DIRECTION OF PEDESTRIAN TRAFFIC FLOW
- EXIST. PVMT.
- NORTH ARROW
- PROPOSED PVMT.
- TEMP. SHORING (LOCATION PURPOSES ONLY)

- WORK AREA
- ONGOING CONSTRUCTION
- REMOVAL
- WEDGING

## SIGNALS

- EXISTING
- PROPOSED
- TEMPORARY
- TEMPORARY
- TEMPORARY
- TEMPORARY

## PAVEMENT MARKINGS

- EXISTING LINES
- TEMPORARY LINES

## TRAFFIC CONTROL DEVICES

- BARRICADE (TYPE III)
- CONE
- DRUM SKINNY DRUM TUBULAR MARKER
- TEMPORARY CRASH CUSHION
- FLASHING ARROW BOARD
- FLAGGER
- LAW ENFORCEMENT
- TRUCK MOUNTED ATTENUATOR (TMA)
- CHANGEABLE MESSAGE SIGN

## TEMPORARY SIGNING

- PORTABLE SIGN
- STATIONARY SIGN
- STATIONARY OR PORTABLE SIGN

## PAVEMENT MARKERS

- CRYSTAL/CRYSTAL
- CRYSTAL/RED
- YELLOW/YELLOW

## PAVEMENT MARKING SYMBOLS

- PAVEMENT MARKING SYMBOLS

## TEMPORARY PAVEMENT MARKING

- PAINT 24" WHITE STOPBAR
- PAINT 4" WHITE EDGELINE
- PAINT 4" YELLOW DOUBLE CENTER

PLOT DRIVER: NCD0T1.pdf\_color\_eng\_50.pht  
 USER: CHARNDEN DATE: 5/31/2019  
 FILE: p:\dwg\ndr\users\01\HDR\US-East\_01\Documents\3322\10001377\10082845\6.0\_CAD\_BITMAP\6.2\_Work\_In\_Progress\N-5812\TrafficControl\TCP\R5812\_IC\_TMP-01A.dgn

APPROVED: *Michelle Ward*  
 DATE: 6/18/2019

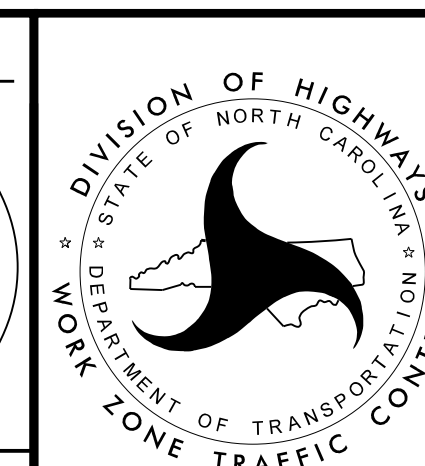
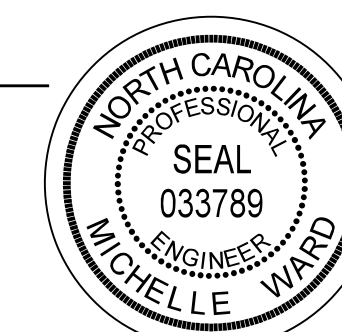

ROADWAY STANDARD  
DRAWINGS & LEGEND

**DOCUMENT NOT CONSIDERED FINAL  
UNLESS ALL SIGNATURES COMPLETED**

## MANAGEMENT STRATEGIES

IN PHASE 1, TRAFFIC IS MAINTAINED ON EXISTING TRAVEL LANES WHILE BOTH SIDES OF THE ROAD ARE CONSTRUCTED, EXCLUDING THE RT SIDE BETWEEN -Y1- & -Y1SPUR-, ALONG -L-. WEDGING OVER EXISTING PAVEMENT WILL BE REQUIRED THROUGHOUT THE PROJECT LENGTH IN ORDER TO MAINTAIN TRAFFIC.

IN PHASE 2, ALL FINAL SIGNALS ARE INSTALLED AND ACTIVATED & TRAFFIC IS PLACED IN THE FINAL PATTERN ALONG -L-. DURING THIS PHASE, THE REMAINDER OF THE RT SIDE OF -L- BETWEEN -Y1- & -Y1SPUR- IS CONSTRUCTED. -Y1- IS CLOSED TO TRAFFIC AND DIVERTED TO -Y1SPUR- TO ALLOW THE REMAINDER OF -Y1- TO BE COMPLETED AWAY FROM TRAFFIC.

IN PHASE 2, STEP 2, ALL LANES ARE OPEN TO TRAFFIC AND THE MONOLITHIC ISLANDS ARE CONSTRUCTED.

ONCE ALL WORK IS COMPLETE, THE FINAL LAYER OF SURFACE COURSE AND FINAL MARKINGS & MARKERS WILL BE PLACED.

## GENERAL NOTES

CHANGES MAY BE REQUIRED WHEN PHYSICAL DIMENSIONS IN THE DETAIL DRAWINGS, STANDARD DETAILS, AND ROADWAY DETAILS ARE NOT ATTAINABLE TO MEET FIELD CONDITIONS, OR RESULT IN DUPLICATE, OR UNDESIRED OVERLAPPING OF DEVICES. MODIFICATIONS MAY INCLUDE: MOVING, SUPPLEMENTING, COVERING, OR REMOVAL OF DEVICES AS DIRECTED BY THE ENGINEER.

THE FOLLOWING GENERAL NOTES APPLY AT ALL TIMES FOR THE DURATION OF THE PROJECT, EXCEPT WHEN OTHERWISE NOTED IN THE PLAN, OR AS DIRECTED BY THE ENGINEER.

### TIME RESTRICTIONS

A) DO NOT CLOSE OR NARROW TRAVEL LANES AS FOLLOWS:

<u>ROAD NAMES</u>	<u>DAY &amp; TIME RESTRICTIONS</u>
-L- (US 13 /MLK JR PKWY)	MONDAY - FRIDAY
US 13/NC 58 (KINGOLD BLVD)	7:00 AM TO 9:00 AM 4:00 PM TO 6:00 PM

B) DO NOT CLOSE OR NARROW TRAVEL LANES DURING HOLIDAYS AND SPECIAL EVENTS AS FOLLOWS:

- ROAD NAMES  
ALL ROADS
- 1) FOR ANY UNEXPECTED OCCURRENCE THAT CREATES UNUSUALLY HIGH TRAFFIC VOLUMES, AS DIRECTED BY THE ENGINEER.
  - 2) FOR NEW YEAR'S, BETWEEN THE HOURS OF 7:00 A.M. DECEMBER 31ST TO 6:00 P.M. JANUARY 2ND. IF NEW YEARS DAY IS ON A FRIDAY, SATURDAY, SUNDAY, OF MONDAY THEN UNTIL 6:00 P.M. THE FOLLOWING TUESDAY.
  - 3) FOR EASTER, BETWEEN THE HOURS OF 7:00 A.M. THURSDAY AND 6:00 P.M. MONDAY.
  - 4) FOR MEMORIAL DAY, BETWEEN THE HOURS OF 7:00 A.M. FRIDAY AND 6:00 P.M. TUESDAY.
  - 5) FOR INDEPENDENCE DAY, BETWEEN THE HOURS OF 7:00 A.M. THE DAY BEFORE INDEPENDENCE DAY AND 6:00 P.M. THE DAY AFTER INDEPENDENCE DAY. IF INDEPENDENCE DAY IS ON A FRIDAY, SATURDAY, SUNDAY, OR MONDAY THEN BETWEEN THE HOURS OF 7:00 A.M. THE THURSDAY BEFORE INDEPENDENCE DAY AND 6:00 P.M. THE TUESDAY AFTER INDEPENDENCE DAY.
  - 6) FOR LABOR DAY, BETWEEN THE HOURS OF 7:00 A.M. FRIDAY AND 6:00 P.M. TUESDAY.
  - 7) FOR THANKSGIVING DAY, BETWEEN THE HOURS OF 7:00 A.M. TUESDAY AND 6:00 P.M. MONDAY.
  - 8) FOR CHRISTMAS, BETWEEN THE HOURS OF 7:00 A.M. THE FRIDAY BEFORE THE WEEK OF CHRISTMAS DAY AND 6:00 P.M. THE FOLLOWING TUESDAY AFTER THE WEEK OF CHRISTMAS.

C) DO NOT CONDUCT ANY HAULING OPERATIONS AGAINST THE FLOW OF TRAFFIC OF AN OPEN TRAVELWAY UNLESS THE HAULING OPERATION IS PROTECTED BY BARRIER OR GUARDRAIL OR AS DIRECTED BY THE ENGINEER.

### LANE AND SHOULDER CLOSURE REQUIREMENTS

- D) REMOVE LANE CLOSURE DEVICES FROM THE LANE WHEN WORK IS NOT BEING PERFORMED BEHIND THE LANE CLOSURE OR WHEN A LANE CLOSURE IS NO LONGER NEEDED, OR AS DIRECTED BY THE ENGINEER.
- E) WHEN PERSONNEL AND/OR EQUIPMENT ARE WORKING WITHIN 15 FT. OF AN OPEN TRAVEL LANE, CLOSE THE NEAREST OPEN SHOULDER USING ROADWAY STANDARD DRAWING NO. 1101.04 UNLESS THE WORK AREA IS PROTECTED BY BARRIER OR GUARDRAIL OR A LANE CLOSURE IS INSTALLED.
- F) WHEN PERSONNEL AND/OR EQUIPMENT ARE WORKING ON THE SHOULDER ADJACENT TO AN UNDIVIDED FACILITY AND WITHIN 5 FT. OF AN OPEN TRAVEL LANE, CLOSE THE NEAREST OPEN TRAVEL LANE USING ROADWAY STANDARD DRAWING NO. 1101.02 UNLESS THE WORK AREA IS PROTECTED BY BARRIER OR GUARDRAIL.
- G) WHEN PERSONNEL AND/OR EQUIPMENT ARE WORKING WITHIN A LANE OF TRAVEL OF AN UNDIVIDED OR DIVIDED FACILITY, CLOSE THE LANE ACCORDING TO THE TRAFFIC CONTROL PLANS, ROADWAY STANDARD DRAWINGS, OR AS DIRECTED BY THE ENGINEER. CONDUCT THE WORK SO THAT ALL PERSONNEL AND/OR EQUIPMENT REMAIN WITHIN THE CLOSED TRAVEL LANE.
- H) DO NOT WORK SIMULTANEOUSLY WITHIN 15 FT. ON BOTH SIDES OF AN OPEN TRAVELWAY RAMP OR LOOP WITHIN THE SAME LOCATION UNLESS PROTECTED WITH BARRIER OR GUARDRAIL.
- I) DO NOT INSTALL MORE THAN 1/2 MILE OF LANE CLOSURE ON ANY ROAD MEASURED FROM THE BEGINNING OF THE MERGE TAPER TO THE END OF THE LANE CLOSURE.
- J) DO NOT INSTALL MORE THAN TWO LANE CLOSURES IN ANY ONE DIRECTION ON ANY ROAD.

### PAVEMENT EDGE DROP OFF REQUIREMENTS

- K) BACKFILL AT A 6:1 SLOPE UP TO THE EDGE AND ELEVATION OF EXISTING PAVEMENT IN AREAS ADJACENT TO AN OPENED TRAVEL LANE THAT HAS AN EDGE OF PAVEMENT DROP-OFF AS FOLLOWS:  
  
BACKFILL DROP-OFFS THAT EXCEED 2 INCHES ON ROADWAYS WITH POSTED SPEED LIMITS OF 45 MPH OR GREATER.  
  
BACKFILL DROP-OFFS THAT EXCEED 3 INCHES ON ROADWAYS WITH POSTED SPEED LIMITS LESS THAN 45 MPH.  
  
BACKFILL WITH SUITABLE COMPACTED MATERIAL, AS APPROVED BY THE ENGINEER, AT NO EXPENSE TO THE DEPARTMENT.
- L) DO NOT EXCEED A DIFFERENCE OF 2 INCHES IN ELEVATION BETWEEN OPEN LANES OF TRAFFIC FOR NOMINAL LIFTS OF 1.5 INCHES. INSTALL ADVANCE WARNING "UNEVEN LANES" SIGNS (W8-11) 500 FT IN ADVANCE AND A MINIMUM OF EVERY HALF MILE THROUGHOUT THE UNEVEN AREA.

### TRAFFIC PATTERN ALTERATIONS

- M) NOTIFY THE ENGINEER THIRTY (30) CALENDAR DAYS PRIOR TO ANY TRAFFIC PATTERN ALTERATION.

PROJ. REFERENCE NO. R-5812	SHEET NO. TMP-2
HDR Engineering, Inc. of the Carolinas 555 Fayetteville St, Suite 900 Raleigh, N.C. 27601 N.C.B.E.L.S. License Number: F-0116	

PLOT DRIVER: NCDOT\_pdf\_color\_eng\_50.pit  
 USER: CHARNDEN  
 FILE: p:\pwhdr\users\01\HDR\_US\_East\_01\Documents\3322\10001377\10082845\6\_0\_CAD\_BITMAP\6.2\_Work\_In\_Progress\R-5812\_TrafficControl\TCP\R5812.TC\_TMP\_02.dgn

REVISTIONS

APPROVED: <i>Michelle Ward</i> DATE: 6/18/2019  SEAL		
<b>TRANSPORTATION OPERATIONS PLAN (MANAGEMENT STRATEGIES &amp; GENERAL NOTES)</b>		
DOCUMENT NOT CONSIDERED FINAL UNLESS ALL SIGNATURES COMPLETED		

# GENERAL NOTES

PROJ. REFERENCE NO. R-5812	SHEET NO. TMP-2A
HDR Engineering, Inc. of the Carolinas 555 Fayetteville St, Suite 900 Raleigh, N.C. 27601 N.C.B.E.L.S. License Number: F-0116	

## SIGNING

- N) INSTALL ADVANCE WORK ZONE SIGNS WHEN WORK IS WITHIN 40 FT. FROM THE EDGE OF TRAVEL LANE AND NO MORE THAT THREE (3) DAYS PRIOR TO THE BEGINNING OF CONSTRUCTION.
- O) ENSURE ALL NECESSARY SIGNING IS IN PLACE PRIOR TO ALTERING ANY TRAFFIC PATTERN.
- P) INSTALL BLACK ON ORANGE "DIP" SIGNS (W8-2) AND/OR "BUMP" SIGNS (W8-1) 500 FT IN ADVANCE OF THE UNEVEN AREA, OR AS DIRECTED BY THE ENGINEER.

## TRAFFIC BARRIER

- Q) INSTALL TEMPORARY BARRIER ACCORDING TO THE TRANSPORTATION MANAGEMENT PLANS A MAXIMUM OF TWO (2) WEEKS PRIOR TO BEGINNING WORK IN ANY LOCATION. ONCE TEMPORARY BARRIER IS INSTALLED AT ANY LOCATION PROCEED IN A CONTINUOUS MANNER TO COMPLETE THE PROPOSED WORK IN THAT LOCATION UNLESS OTHERWISE STATED IN THE TRANSPORTATION MANAGEMENT PLANS OR AS DIRECTED BY THE ENGINEER.

DO NOT PLACE BARRIER DIRECTLY ON ANY SURFACE OTHER THAN ASPHALT OR CONCRETE.

ONCE TEMPORARY BARRIER IS INSTALLED AT ANY LOCATION AND NO WORK IS PERFORMED BEHIND THE TEMPORARY BARRIER FOR A PERIOD LONGER THAN TWO (2) MONTHS, REMOVE / RESET TEMPORARY BARRIER AT NO COST TO THE DEPARTMENT UNLESS OTHERWISE STATED IN THE TRANSPORTATION MANAGEMENT PLANS, TEMPORARY BARRIER IS PROTECTING A HAZARD, OR AS DIRECTED BY THE ENGINEER.

INSTALL TEMPORARY BARRIER WITH THE TRAFFIC FLOW BEGINNING WITH THE UPSTREAM SIDE OF TRAFFIC. REMOVE TEMPORARY BARRIER AGAINST THE TRAFFIC FLOW BEGINNING WITH THE DOWNSTREAM SIDE OF TRAFFIC.

INSTALL AND SPACE DRUMS NO GREATER THAN TWICE THE POSTED SPEED LIMIT (MPH) TO CLOSE OR KEEP THE SECTION OF THE ROADWAY CLOSED UNTIL THE TEMPORARY BARRIER CAN BE PLACED OR AFTER THE TEMPORARY BARRIER IS REMOVED.

- R) PROTECT THE APPROACH END OF MOVABLE/PORTABLE CONCRETE BARRIER AT ALL TIMES DURING THE INSTALLATION AND REMOVAL OF THE BARRIER BY EITHER A TRUCK MOUNTED ATTENUATOR (MAXIMUM 72 HOURS) OR A TEMPORARY CRASH CUSHION.

PROTECT THE APPROACH END OF MOVABLE/PORTABLE CONCRETE BARRIER FROM ONCOMING TRAFFIC AT ALL TIMES BY A TEMPORARY CRASH CUSHION UNLESS THE APPROACH END OF MOVABLE/PORTABLE CONCRETE BARRIER IS OFFSET FROM ONCOMING TRAFFIC AS FOLLOWS OR AS SHOWN IN THE PLANS: (SEE ALSO 1101.05)

POSTED SPEED LIMIT	MINIMUM OFFSET
40 OR LESS	15 FT
45 - 50	20 FT
55	25 FT
60 MPH OR HIGHER	30 FT

## TRAFFIC CONTROL DEVICES

- S) WHEN LANE CLOSURES ARE NOT IN EFFECT SPACE CHANNELIZING DEVICES IN WORK AREAS NO GREATER IN FEET THAN TWICE THE POSTED SPEED LIMIT (MPH) EXCEPT, 10 FT ON-CENTER IN RADII, AND 3 FT OFF THE EDGE OF AN OPEN TRAVELWAY. REFER TO STANDARD SPECIFICATIONS FOR ROADS AND STRUCTURES SECTIONS 1130 (DRUMS), 1135 (CONES) AND 1180 (SKINNY DRUMS) FOR ADDITIONAL REQUIREMENTS.
- T) PLACE TYPE III BARRICADES, WITH "ROAD CLOSED" SIGN R11-2 ATTACHED, OF SUFFICIENT LENGTH TO CLOSE ENTIRE ROADWAY.
- U) PLACE ADDITIONAL SETS OF THREE CHANNELIZING DEVICES (DRUMS, SKINNY DRUMS OR CONES) PERPENDICULAR TO THE EDGE OF TRAVELWAY ON 500 FT CENTERS WHEN UNOPENED LANES ARE CLOSED TO TRAFFIC.

## PAVEMENT MARKINGS AND MARKERS

- V) INSTALL TEMPORARY PAVEMENT MARKINGS AND TEMPORARY PAVEMENT MARKERS ON INTERIM LAYERS OF PAVEMENT AS FOLLOWS:

ROAD NAME	MARKING	MARKER
ALL ROADS	PAINT (4")	TEMPORARY RAISED

- W) PLACE ONE APPLICATION OF PAINT FOR TEMPORARY TRAFFIC PATTERNS. PLACE A SECOND APPLICATION OF PAINT SIX (6) MONTHS AFTER THE INITIAL APPLICATION AND EVERY SIX MONTHS AS DIRECTED BY THE ENGINEER.
- X) TIE PROPOSED PAVEMENT MARKING LINES TO EXISTING PAVEMENT MARKING LINES.
- Y) REMOVE/REPLACE ANY CONFLICTING/DAMAGED PAVEMENT MARKINGS AND MARKERS BY THE END OF EACH DAY'S OPERATION.
- Z) TRACE THE EXISTING AND PROPOSED MONOLITHIC ISLAND LOCATIONS WITH PROPER COLOR PAVEMENT MARKINGS PRIOR TO REMOVAL AND INSTALLATION. PLACE DRUMS TO DELINEATE ANY EXISTING AND PROPOSED MONOLITHIC ISLANDS AFTER REMOVAL AND BEFORE INSTALLATION.

## MISCELLANEOUS

- AA) LAW ENFORCEMENT MAY BE USED TO MAINTAIN TRAFFIC THROUGH THE WORK AREA AND/OR INTERSECTIONS, AS DIRECTED BY THE ENGINEER.
- BB) ALL CURB RAMP LOCATIONS SHALL BE DERIVED FROM STATIONING SHOWN ON PAVEMENT MARKING PLANS OR AS DIRECTED BY THE ENGINEER IN COORDINATION WITH THE SIGNING AND DELINEATION UNIT.
- CC) IF PORTIONS OF EXISTING GUARDRAIL ARE REMOVED, PROTECT APPROACH AND TRAILING END OF REMAINING GUARDRAIL WITH TEMPORARY END UNITS (GREU TL-3). TMA MAY BE USED AS PROTECTION FOR A MAXIMUM 72 HOURS. IF PROPOSED GUARDRAIL PORTIONS ARE INSTALLED, PROTECT APPROACH AND TRAILING ENDS WITH SAME AS TEMPORARY.

APPROVED: *Michelle Ward*

DATE: 6/18/2019

SEAL

DOCUMENT NOT CONSIDERED FINAL  
UNLESS ALL SIGNATURES COMPLETED

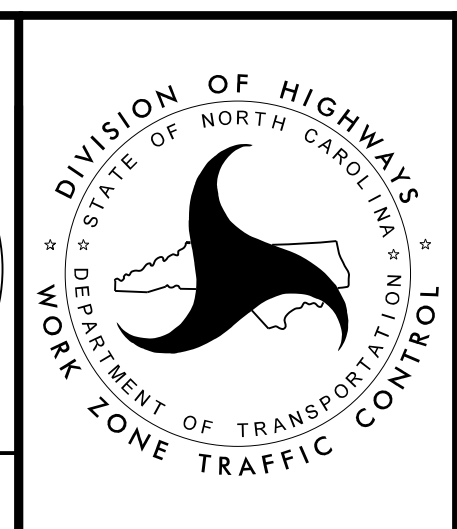

TRANSPORTATION  
OPERATIONS PLAN  
(MANAGEMENT STRATEGIES  
& GENERAL NOTES)

PLOT DRIVER: NCDOT\_color\_eng\_50.plt  
 USER: CHARNDEN  
 DATE: 5/31/2019  
 TIME: 3:46:19 PM  
 FILE: p:\pwhdr\users\01\HDR\_US\_East\_01\Documents\3322\10001377\10082845\6\_0\_CAD\_BITMAP6.2\_Work\_In\_Progress\R-5812\_TrafficControl\TCP\R5812.TC\_TMP\_02.dgn

REVISIONS

# PHASING

PROJ. REFERENCE NO.	SHEET NO.
R-5812	TMP-3

**HDR** HDR Engineering, Inc. of the Carolinas  
555 Fayetteville St, Suite 900 Raleigh, N.C. 27601  
N.C.B.E.L.S. License Number: F-0116

## NOTES:

BEFORE BEGINNING ANY CONSTRUCTION ACTIVITIES, INSTALL ADVANCE WARNING SIGNS ACCORDING TO RSD 1101.01. FIELD VERIFY LOCATIONS WITH THE RESIDENT ENGINEER PRIOR TO INSTALLATION.

MAINTAIN ACCESS TO ALL RESIDENCES, EMERGENCY SERVICES, AND BUSINESSES AT ALL TIMES. PRIOR TO INCORPORATIONS, OBTAIN WRITTEN APPROVAL FROM THE ENGINEER ON METHOD TO MAINTAIN ACCESS.

COMPLETE ANY PROPOSED OR TEMPORARY WIDENING IN SUCH A MANNER THAT NO PONDING OF WATER WILL OCCUR WITHIN THE TRAVEL LANE.

WHEN WEDGING OVER THE EXISTING PAVEMENT, WEDGE TO PROPOSED ELEVATION (LESS THE FINAL LAYER OF SURFACE COURSE), OR WEDGE AS NEEDED TO MAINTAIN TRAFFIC. MAINTAIN POSITIVE DRAINAGE AND MAINTAIN A MAXIMUM .04 ROLLOVER IN BOTH EXISTING AND/OR TEMPORARY TRAVEL LANES.

REPLACE MARKINGS AND RETURN TRAFFIC TO THE CURRENT TRAFFIC PATTERN AT THE END OF EACH WORK PERIOD UNLESS OTHERWISE NOTED IN THE PHASING OR DIRECTED BY THE ENGINEER.

WHEN USING LANE CLOSURES (RSD 1101.02), RETURN TRAFFIC TO EXISTING AND/OR CURRENT TEMPORARY TRAFFIC PATTERN UPON ACTIVITIES COMPLETION, UNLESS OTHERWISE NOTED IN THE PHASING.

WHEN PHASING STATES TO USE LANE CLOSURES, REFER TO THE FOLLOWING FOR ALL EXISTING AND PROPOSED ROADS:

- ALL TWO-LANE/TWO-WAY FACILITIES - SEE RSD 1101.02, SHEET 1 OF 14
- ALL 3-LANE OR 5-LANE ROADWAYS - SEE RSD 1101.02, SHEET 2 OF 14
- ALL MULTI-LANE ROADWAYS - SEE RSD 1101.02, SHEET 3 OF 14
- EXIT RAMP - SEE RSD 1101.02, SHEET 10 OF 14

FOR ALL SHOULDER CLOSURES, SEE RSD 1101.04.

WHEN INSTALLING AND ACTIVATING FINAL SIGNALS, USE LANE CLOSURES (RSD 1101.02, SHEETS 1, 2, AND 3) AND LAW ENFORCEMENT.

COMPLETE PAVING UP TO BUT NOT INCLUDING THE FINAL LAYER OF SURFACE COURSE UNTIL STATED TO PLACE FINAL LAYER IN THE PHASING.

## PHASE 1

**STEP 1**  
USING LANE CLOSURES, OBLITERATE AND PAVE THE EXISTING MEDIAN ISLANDS AT THE -L-/KINGOLD BLVD AND -L-/Y1SPUR- INTERSECTIONS.

USING LANE CLOSURES, CONSTRUCT PROPOSED WEDGING AND WIDENING ALONG -L- FROM PROJECT BEGIN TO PROJECT END, EXCLUDING RT SIDE BETWEEN -Y1- AND -Y1SPUR-. THIS INCLUDES CONSTRUCTION OF RETAINING WALL FROM -L- STA. 39+00 +/- TO STA. 42+50 +/-.

NOTE: CONDUCT WIDENING OPERATION BEHIND EXISTING GUARDRAIL AS MUCH AS POSSIBLE BEFORE REMOVING EXISTING GUARDRAIL TO COMPLETE WIDENING.

USING LANE CLOSURES/LANE NARROWING, CONSTRUCT RT SIDE WIDENING ALONG -Y1- (NW 2ND ST RAMP) & -Y1SPUR-.

**STEP 2**  
USING LANE CLOSURES, PLACE TEMPORARY MARKINGS AND SHIFT TRAFFIC ALONG -L- AND -Y1- TO THE PHASE 2 TRAFFIC PATTERN.

\* FINAL SIGNALS WILL BE REQUIRED AT THE FOLLOWING LOCATIONS:  
(SEE NOTE TO THE LEFT FOR SIGNAL INSTALLATION)

- US 13 (KINGOLD BLVD)/US 13 (MLK JR. BLVD) (#02-0494)
- US 13 (MLK JR. BLVD)/US 258 (#02-0336)

## PHASE 2

**STEP 1**  
CLOSE -Y1- AND DIVERT TRAFFIC TO -Y1SPUR-, THEN CONSTRUCT THE REMAINDER OF -Y1- AWAY FROM TRAFFIC.

USING LANE CLOSURES, CONSTRUCT REMAINDER OF LT SIDE OF -Y1SPUR- AND RT SIDE OF -L- BETWEEN -Y1- AND -Y1SPUR-.

USING LANE CLOSURES AS NEEDED, COMPLETE SIDEWALK CONSTRUCTION ALONG -L- AND OPEN TO PEDESTRIAN TRAFFIC.

**STEP 2**  
PLACE TEMPORARY MARKINGS AS SHOWN AND REOPEN -Y1- TO TRAFFIC, THEN USING LANE CLOSURES, CONSTRUCT THE PROPOSED MONOLITHIC ISLANDS AT THE -L-/KINGOLD BLVD AND -L-/Y1SPUR- INTERSECTIONS.

**STEP 3**  
USING LANE CLOSURES, PLACE THE FINAL LAYER OF SURFACE COURSE AND FINAL MARKINGS AND MARKERS & REOPEN TRAFFIC TO THE FINAL PATTERN.

**STEP 4**  
REMOVE ALL REMAINING TRAFFIC CONTROL DEVICES.

REVISIONS

PLOT DRIVER: NCDOT\_pdf\_color\_eng\_50.plt PENTABLE: NCDOT\_tcp.tbl  
USER: CHARNDEN DATE: 5/31/2019 TIME: 3:46:29 PM  
FILE: p:\p\hndr\users\01\hdr\US\_East\_01\Documents\3322\10001377\10082845\6\_0\_CAD\_BITMAP\6\_2\_Work\_In\_Progress\R-5812\_TrafficControl\TCP\R5812\_Tc\_TMP-03.dgn

APPROVED: *Michelle Ward*  
DATE: 6/18/2019

SEAL



**DOCUMENT NOT CONSIDERED FINAL  
UNLESS ALL SIGNATURES COMPLETED**

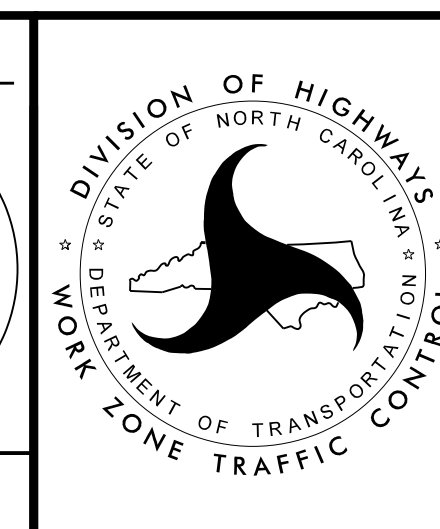

TEMPORARY TRAFFIC CONTROL PHASING

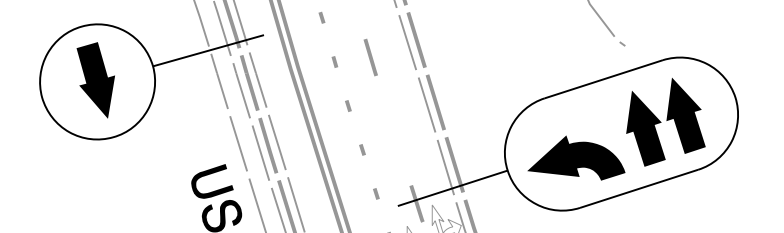
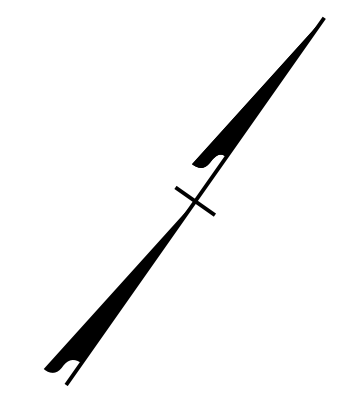

US 13/258 & NC 58  
(KINGOLD BLVD)

10 MAINTAIN EXISTING SIGNAL POLE AND EXISTING SIDEWALK DURING PHASE 1 CONSTRUCTION

TRAFFIC DRUMS @ 45' SPACING

15

PARKWOOD DR

TRAFFIC DRUMS @ 90' SPACING

20

INDUSTRIAL DR

EXISTING SIGNAL #02-0494

OBLITERATE EXISTING ISLAND AND PAVE

MAINTAIN EXISTING SIGNAL POLE AND EXISTING SIDEWALK DURING PHASE 1 CONSTRUCTION

-L-  
US 13 (MLK JR PKWY)

TRAFFIC DRUMS @ 90' SPACING

PROFESSIONAL DR

MATCHLINE -L- STA. 22+00  
SEE TMP-5

REVISIONS

US 258/NC 58  
(KINGOLD BLVD)

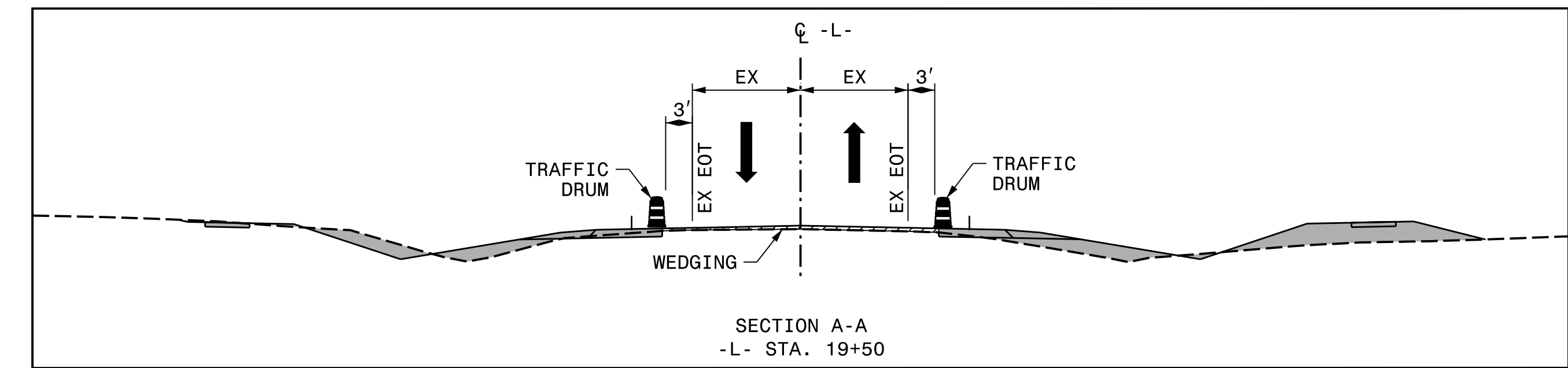

PLOT DRIVER: NCDOT\_pdf\_color\_eng\_50.pit  
 USER: CHARNDEN  
 DATE: 5/31/2019  
 TIME: 3:46:46 PM  
 FILE: p:\pwhdr\users\01\HDR\_US\_East\_01\Documents\3322\10001377\10082845\6\_0\_CAD\_BITMAP\6.2\_Work\_In\_Progress\R-5812\_TrafficControl\TCP\R5812\_TC\_TMP-04.dgn

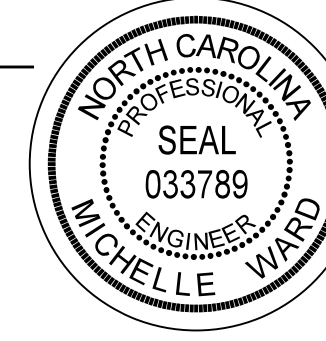
APPROVED: *Michelle Ward*  
 DATE: 6/18/2019  
 SEAL  

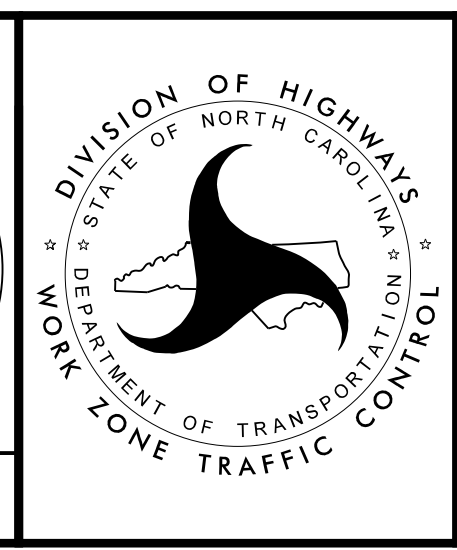

PHASE 1

DOCUMENT NOT CONSIDERED FINAL  
UNLESS ALL SIGNATURES COMPLETED

PROJ. REFERENCE NO. R-5812	SHEET NO. TMP-5
 HDR Engineering, Inc. of the Carolinas 555 Fayetteville St, Suite 900 Raleigh, N.C. 27601 N.C.B.E.L.S. License Number: F-0116	

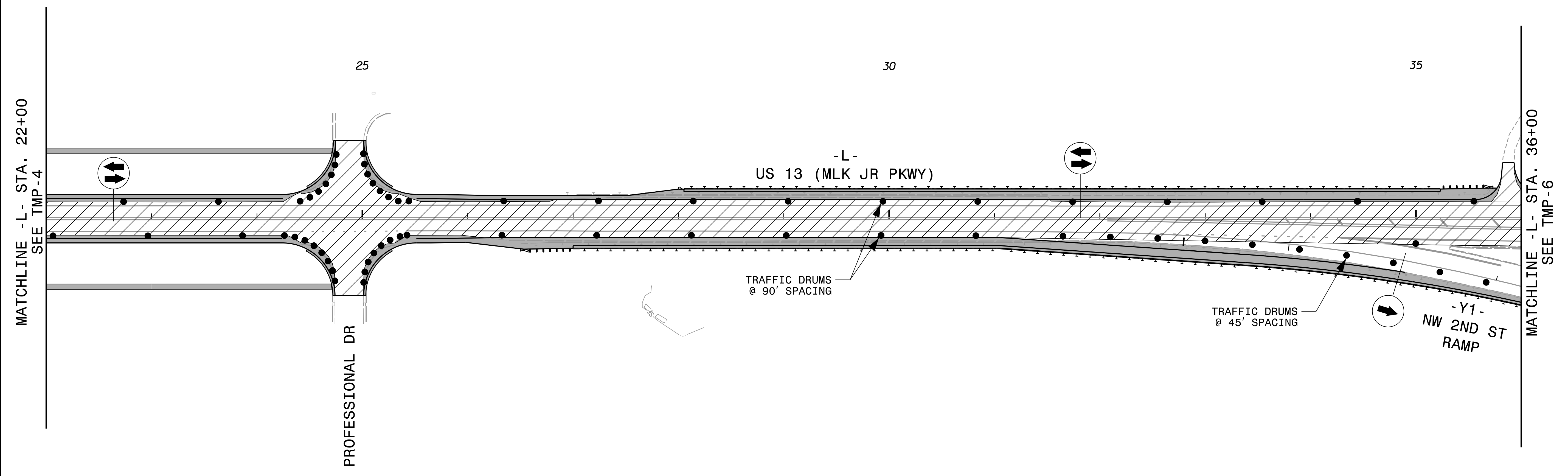
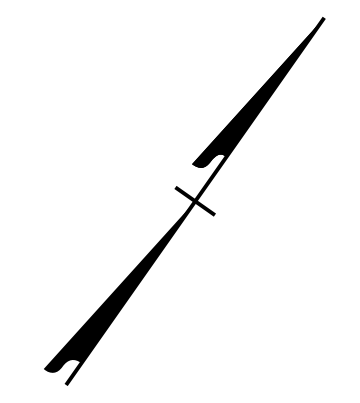

REVISIONS

PLOT DRIVER: NCDOT\_pdf\_color\_eng\_50.plt PENTABLE: NCDOT\_tcp.tbl  
 USER: CHARNDEN DATE: 5/31/2019 TIME: 3:46:59 PM  
 FILE: pw:\pwhdr\users\01\HDR\_US\_East\_01\Documents\3322\10001377\10082845\6\_0\_CAD\_BITMAP\6.2\_Work\_In\_Progress\R-5812\_TrafficControl\TCP\R5812\_Tc\_TMP-05.dgn

APPROVED: *Michelle Ward*  
 DATE: 6/18/2019

SEAL

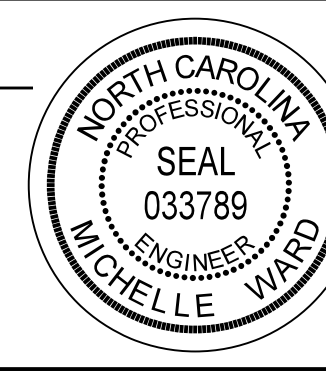

**DOCUMENT NOT CONSIDERED FINAL  
 UNLESS ALL SIGNATURES COMPLETED**

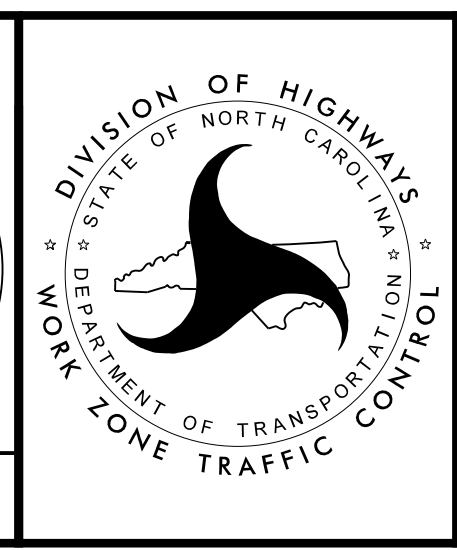

PHASE 1



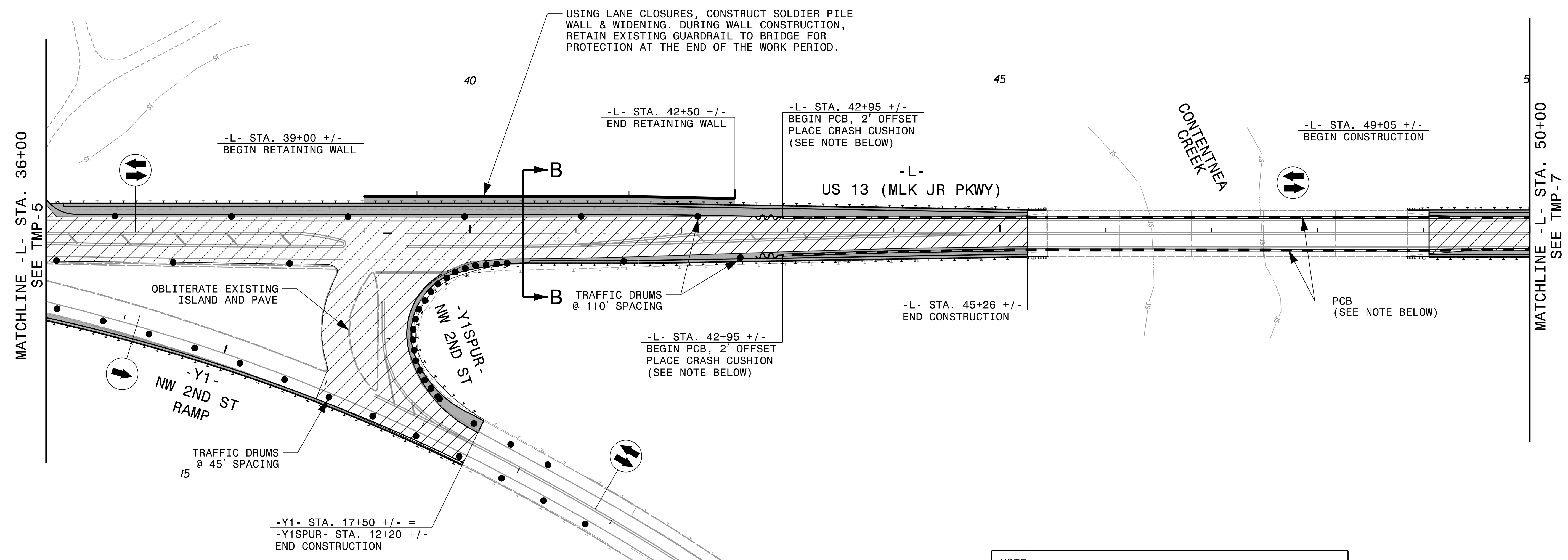
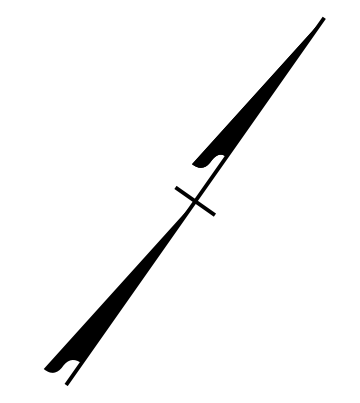
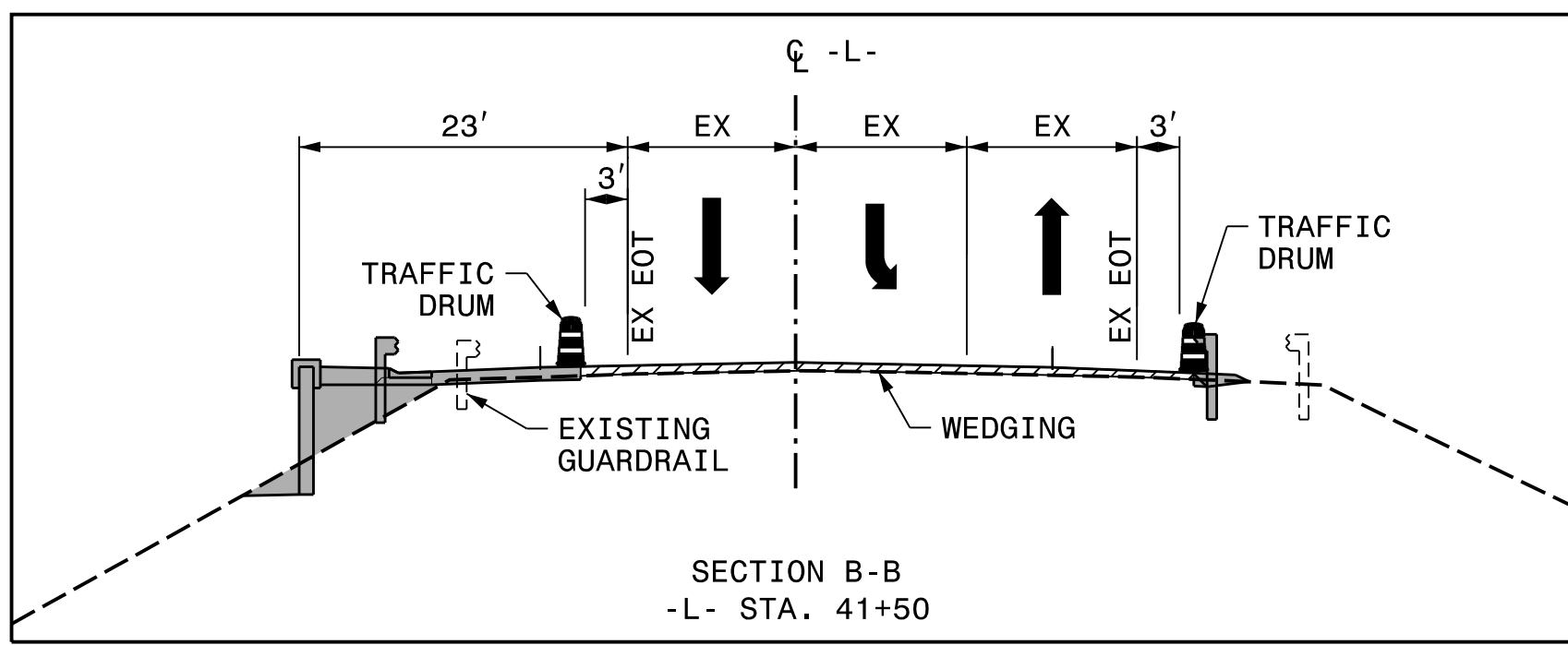

**NOTE:**  
INSTALL PCB WITH CRASH CUSHIONS ACROSS BRIDGE PRIOR TO REMOVING EXISTING GUARDRAIL AT BRIDGE LOCATION. ONCE PROPOSED GUARDRAIL IS INSTALLED, REMOVE PCB AND CRASH CUSHIONS.

APPROVED: *Michelle Ward*  
DATE: 6/18/2019  
SEAL  
NORTH CAROLINA PROFESSIONAL ENGINEER SEAL 033789 MICHELLE WARD



PHASE 1

PLOT DRIVER: NCDOT\_pdf\_color\_eng\_50.pit  
 USER: CHARNDEN  
 DATE: 5/31/2019  
 TIME: 3:47:13 PM  
 FILE: p:\pwhdr\users\01\hdr\US\_East\_01\Documents\3322\10001377\10082845\6\_0\_CAD\_BITMAP\6.2\_Work\_In\_Progress\TrafficControl\TCP\R5812\_TC\_TMP\_06.dgn

REVISIONS

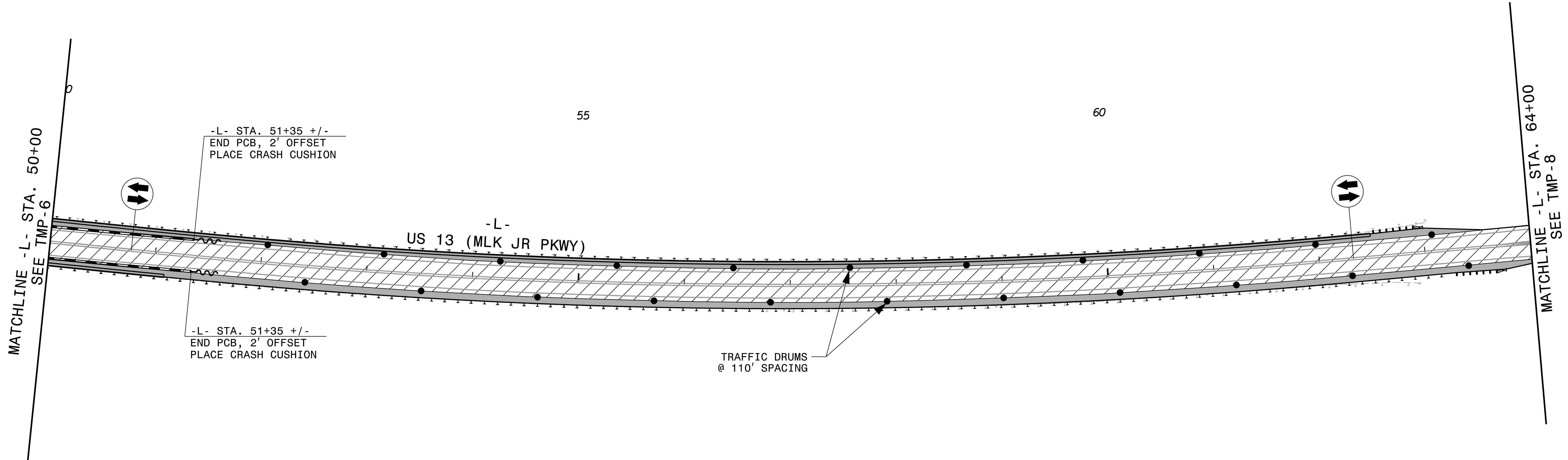
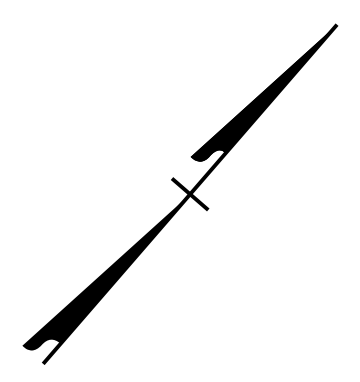

REVISIONS

PLOT DRIVER: NCDOT\_pdf\_color\_eng\_50.plt PENTABLE: NCDOT\_tcp.tbl  
 USER: CHARNDEN DATE: 5/31/2019 TIME: 3:47:26 PM  
 FILE: pw:\pwhdr\users\01\HDR\_US\_East\_01\Documents\3322\10001377\10082845\6\_0\_CAD\_BITMAP\6.2\_Work\_In\_Progress\R-5812\_TrafficControl\TCP\R5812\_TC\_TMP-07.dgn

APPROVED: *Michelle Ward*  
 DATE: 6/18/2019  
 SEAL

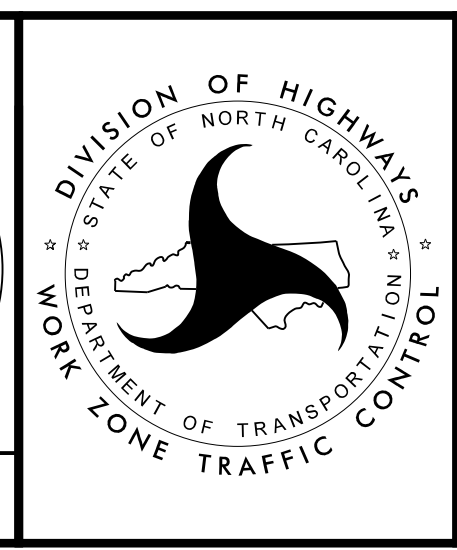

PHASE 1

DOCUMENT NOT CONSIDERED FINAL  
UNLESS ALL SIGNATURES COMPLETED

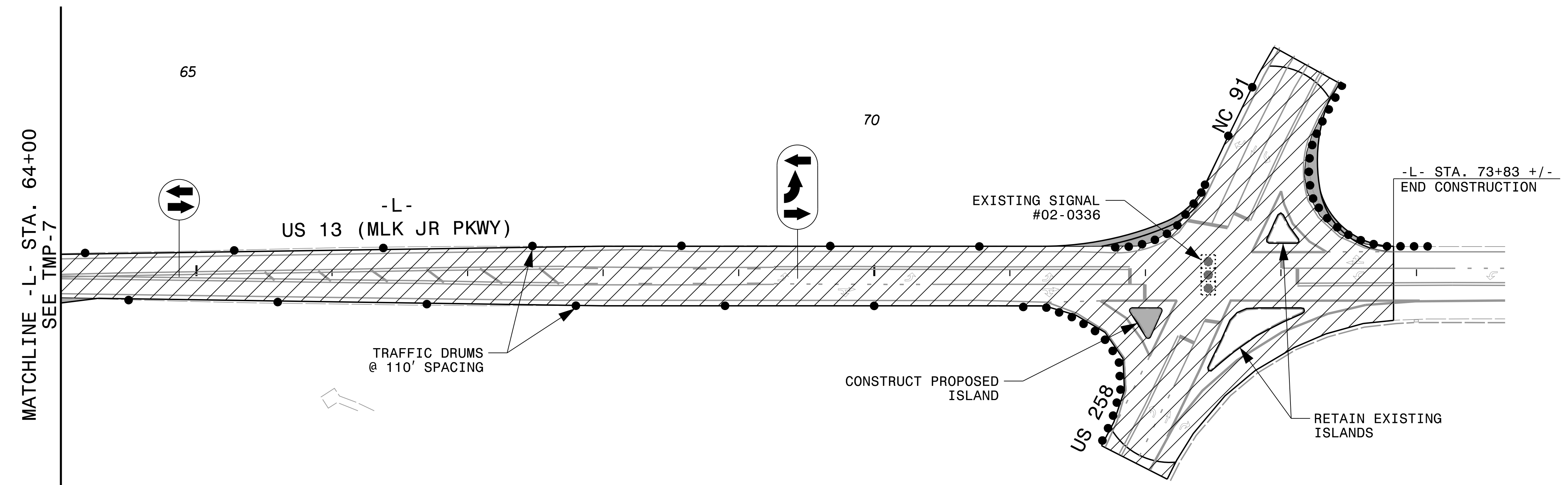
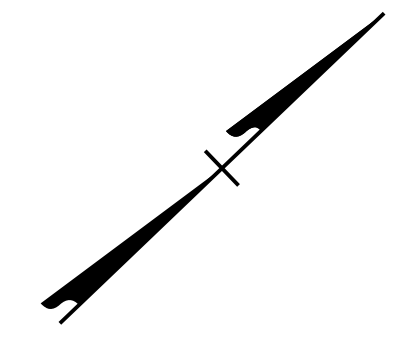

REVISIONS

PLOT DRIVER: NCDOT\_pdf\_color\_eng\_50.plt PENTABLE: NCDOT\_tcp.tbl  
 USER: CHARNDEN DATE: 5/31/2019 TIME: 3:47:37 PM  
 FILE: p:\pwhdr\users\01\HDR\_US\_East\_01\Documents\3322\10001377\10082845\6\_0\_CAD\_BITMAP\6\_2\_Work\_In\_Progress\R-5812\_TrafficControl\TCP\R5812\_Tc\_TMP-08.dgn

APPROVED: *Michelle Ward*  
 DATE: 6/18/2019

SEAL

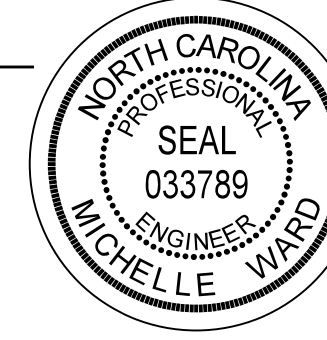

**DOCUMENT NOT CONSIDERED FINAL  
UNLESS ALL SIGNATURES COMPLETED**

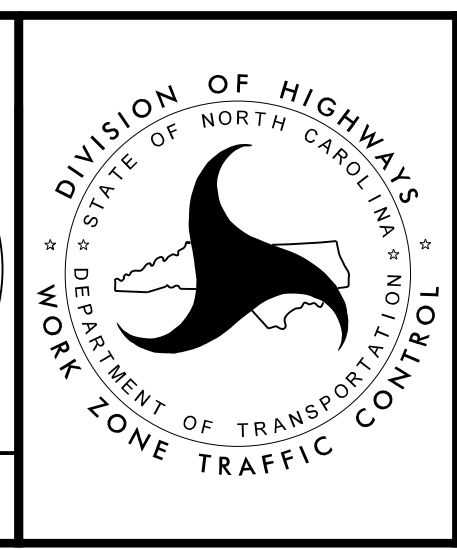

PHASE 1

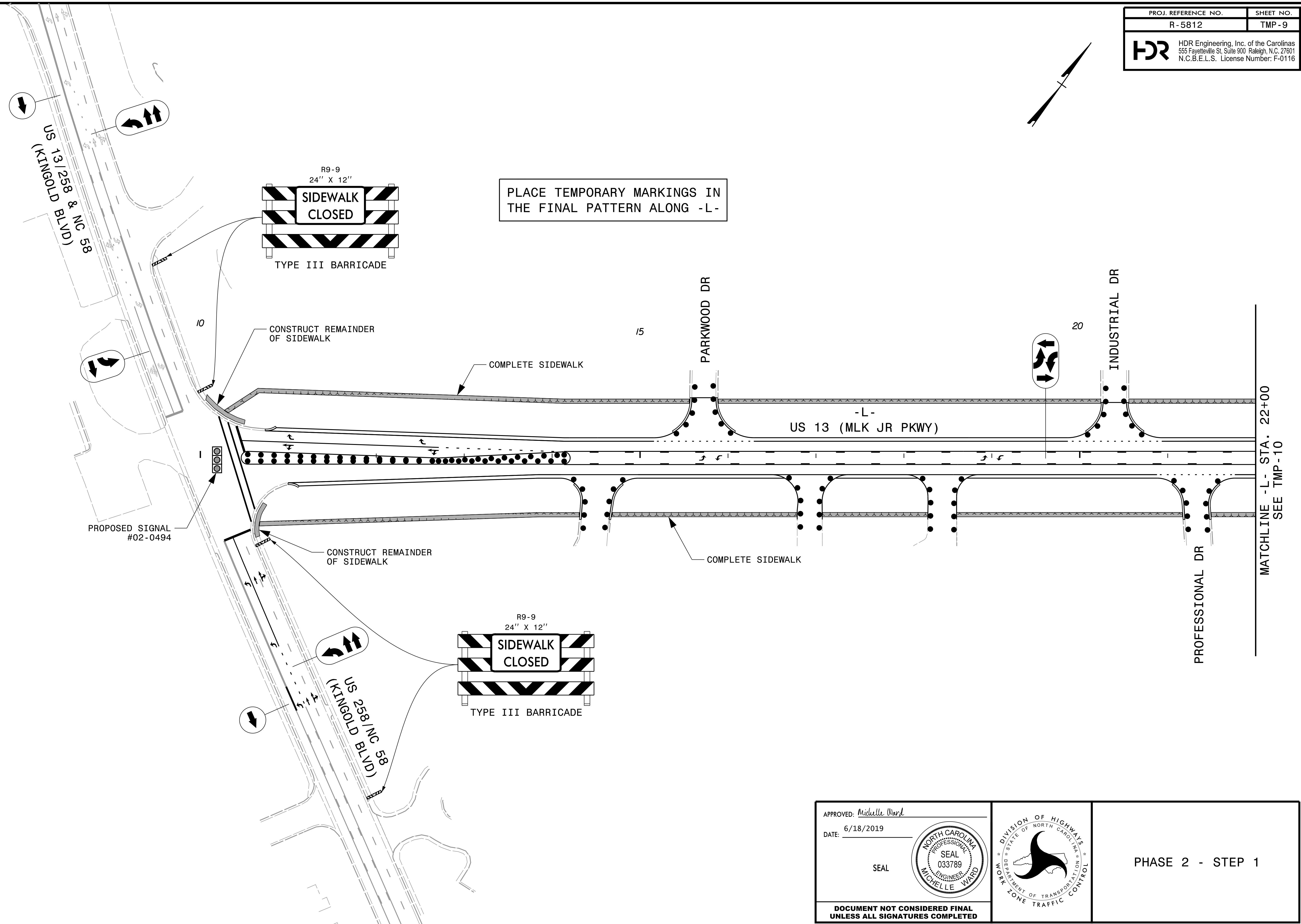
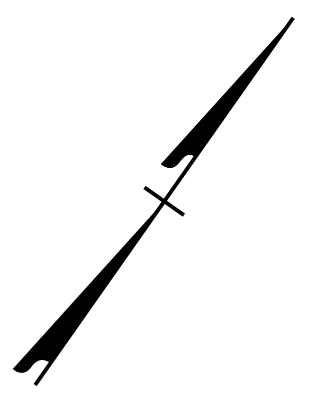

PLACE TEMPORARY MARKINGS IN THE FINAL PATTERN ALONG -L-

PROPOSED SIGNAL #02-0494

MATCHLINE -L- STA. 22+00  
 SEE TMP-10

REVISIONS

PLOT DRIVER: NCDOT\_pdr\_color\_eng\_50.plt  
 USER: CHARNDEN  
 DATE: 5/31/2019  
 TIME: 3:47:53 PM  
 FILE: p:\pwhdr\users\01\HDR\_US\_East\_01\Documents\3322\10001377\10082845\6\_0\_CAD\_BITMAP\6\_2\_Work\_In\_Progress\R-5812\_TrafficControl\TCP\R5812\_Tc\_TMP-09.dgn

APPROVED: *Michelle Ward*  
 DATE: 6/18/2019  
 SEAL

**DOCUMENT NOT CONSIDERED FINAL UNLESS ALL SIGNATURES COMPLETED**



PHASE 2 - STEP 1

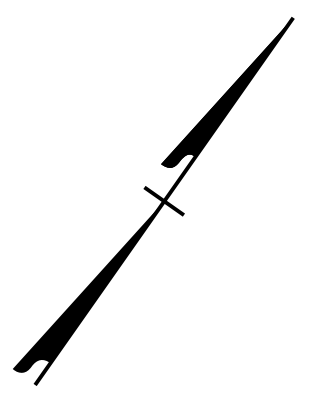

PLACE TEMPORARY MARKINGS IN THE FINAL PATTERN ALONG -L- EXCEPT AS SHOWN

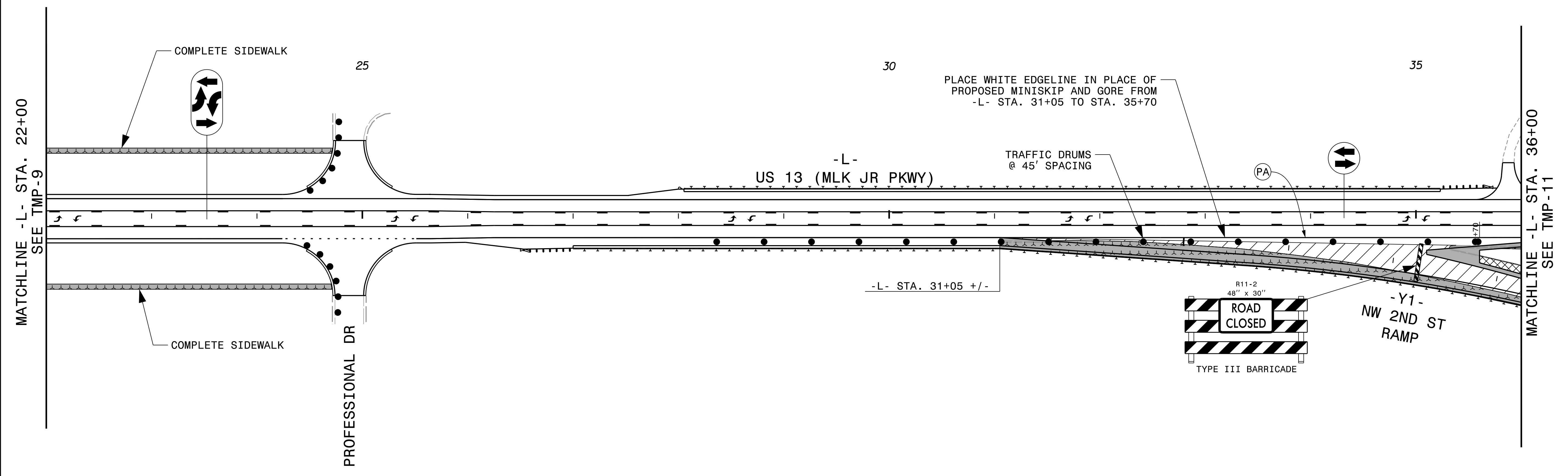

REVISIONS

PLOT DRIVER: NCDOT\_pdf\_color\_eng\_50.plt  
 USER: CHARNDEN  
 DATE: 5/31/2019  
 TIME: 3:48:07 PM  
 FILE: p:\pwhdr\users\01\HDR\_US\_East\_01\Documents\3322\10001377\10082845\6\_0\_CAD\_BITMAP\6.2\_Work\_In\_Progress\R-5812\_TrafficControl\TCP\R5812\_Tc\_TMP-10.dgn

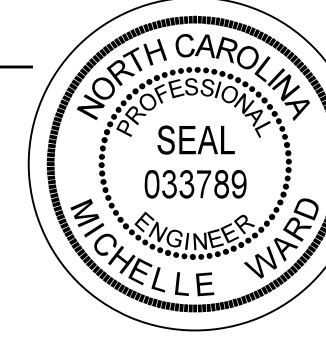
APPROVED: *Michelle Ward*  
 DATE: 6/18/2019  
 SEAL  

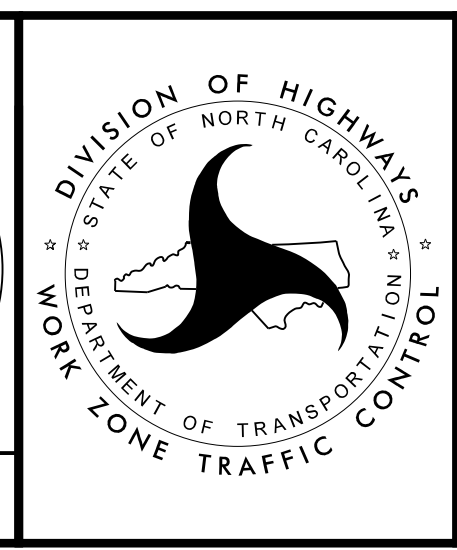

PHASE 2 - STEP 1

DOCUMENT NOT CONSIDERED FINAL UNLESS ALL SIGNATURES COMPLETED

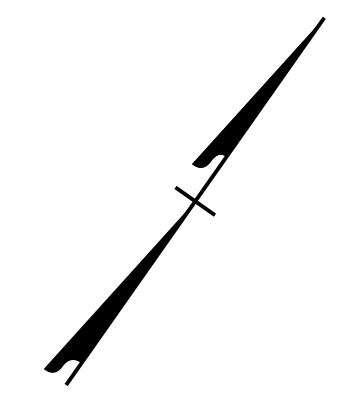

PLACE TEMPORARY MARKINGS IN THE FINAL PATTERN ALONG -L-

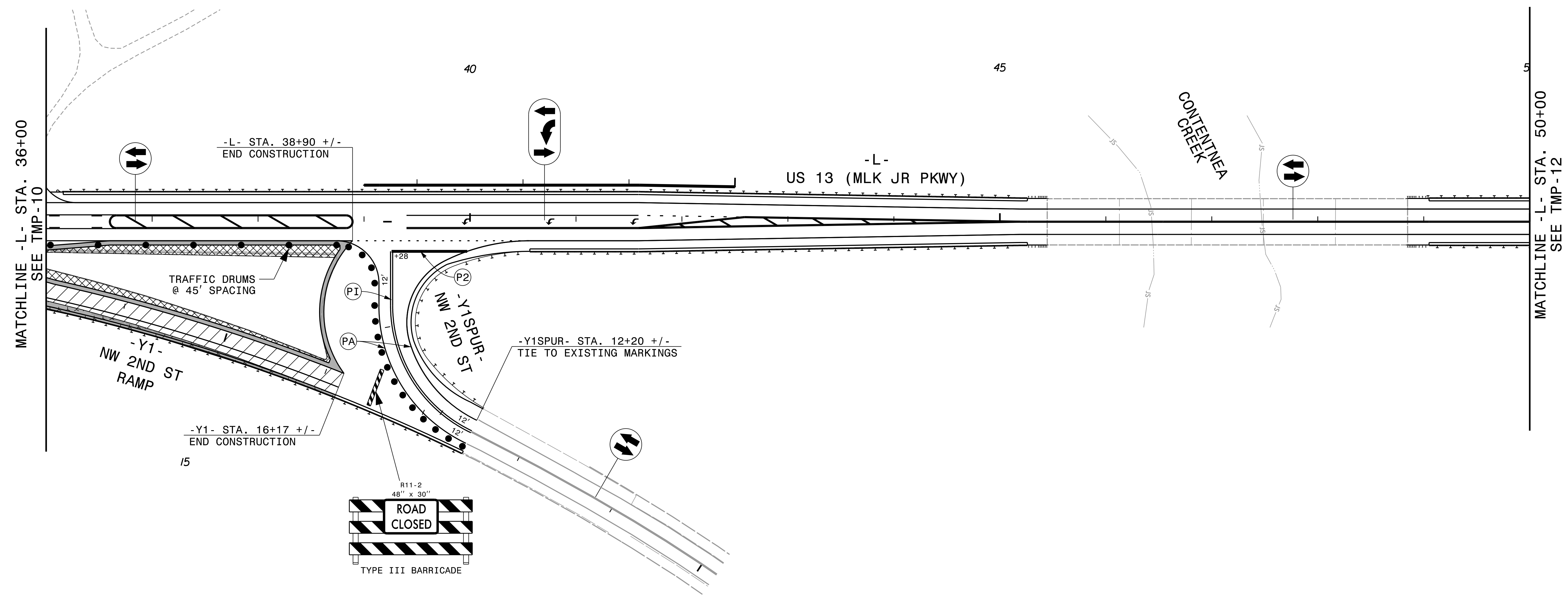

REVISIONS

PLOT DRIVER: NCDOT\_color\_eng\_50.plt  
 USER: CHARNDEN  
 DATE: 5/31/2019  
 TIME: 3:48:18 PM  
 FILE: p:\p\hndr\users\01\hndr\US\_East\_01\Documents\3322\10001377\10082845\6\_0\_CAD\_BITMAP\6\_2\_Work\_In\_Progress\R-5812\_TrafficControl\TCP\R5812\_TC\_TMP-11.dgn

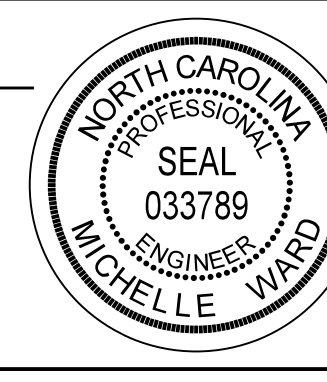
APPROVED: *Michelle Ward*  
 DATE: 6/18/2019  
 SEAL  

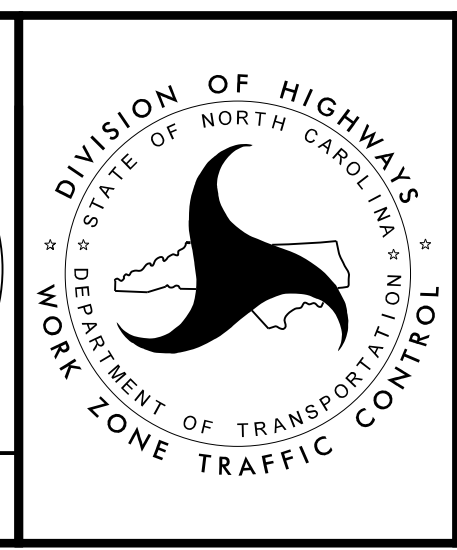

PHASE 2 - STEP 1

DOCUMENT NOT CONSIDERED FINAL UNLESS ALL SIGNATURES COMPLETED

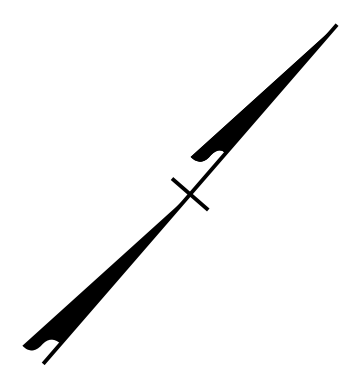

PLACE TEMPORARY MARKINGS IN THE FINAL PATTERN ALONG -L-

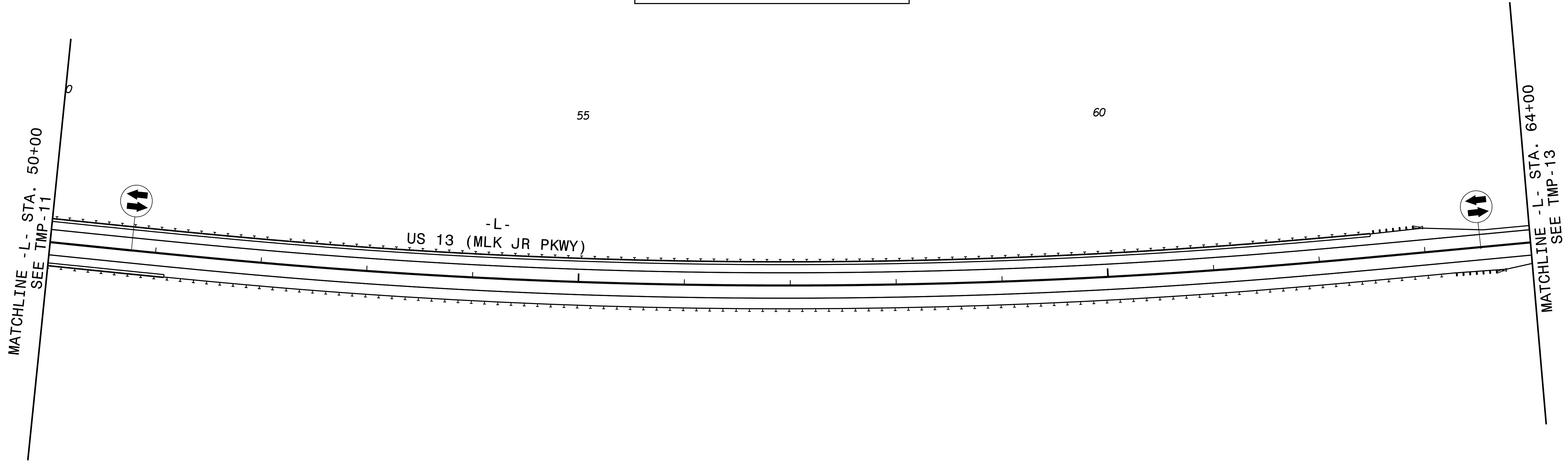

REVISIONS

PLOT DRIVER: NCDOT\_pdf\_color\_eng\_50.plt PENTABLE: NCDOT\_tcp.tbl  
 USER: CHARNDEN DATE: 5/31/2019 TIME: 3:48:33 PM  
 FILE: pw:\pwhdr\users\01\HDR\_US\_East\_01\Documents\3322\10001377\10082845\6\_0\_CAD\_BITMAP\6.2\_Work\_In\_Progress\R-5812\_TrafficControl\TCP\R5812\_TC\_TMP-12.dgn

APPROVED: *Michelle Ward*  
 DATE: 6/18/2019  
 SEAL  
 NORTH CAROLINA PROFESSIONAL SEAL  
 033789  
 ENGINEER MICHELLE WARD

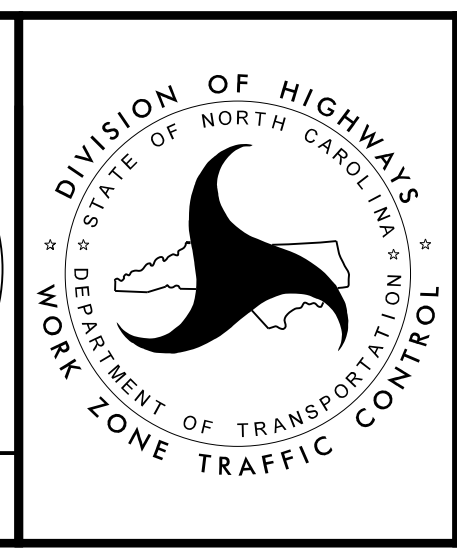

PHASE 2 - STEP 1

DOCUMENT NOT CONSIDERED FINAL UNLESS ALL SIGNATURES COMPLETED

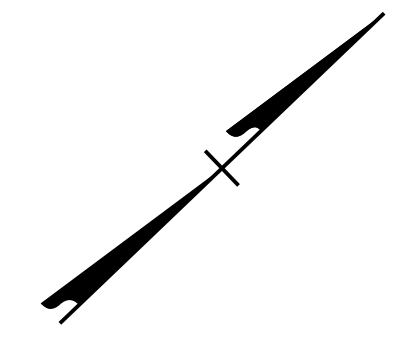

MATCHLINE -L- STA. 64+00  
SEE TMP-12



-L-  
US 13 (MLK JR PKWY)

PLACE TEMPORARY MARKINGS  
THE FINAL PATTERN

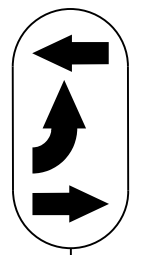

PROPOSED SIGNAL  
#02-0336

NC 91

US 258

PLOT DRIVER: NCDOT\_pdf\_color\_eng\_50.plt PENTABLE: NCDOT\_tcp.tbl  
 USER: CHARNDEN DATE: 5/31/2019 TIME: 3:48:47 PM  
 FILE: p:\pwhdr\users\01\HDR\_US\_East\_01\Documents\3322\10001377\10082845\6\_0\_CAD\_BITMAP\6.2\_Work\_In\_Progress\R-5812\_TrafficControl\TCP\R5812\_TC\_TMP-13.dgn

REVISIONS

APPROVED: *Michelle Ward*  
 DATE: 6/18/2019

SEAL

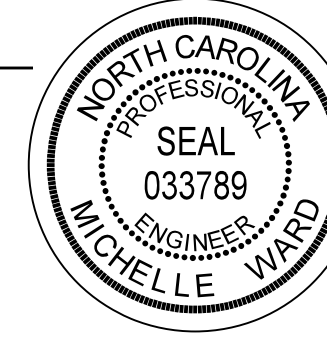

**DOCUMENT NOT CONSIDERED FINAL  
UNLESS ALL SIGNATURES COMPLETED**

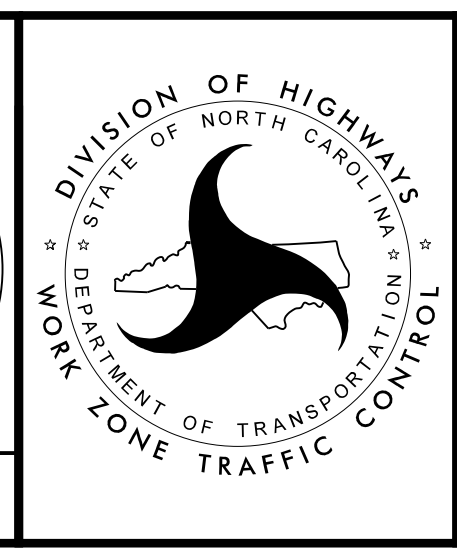

PHASE 2 - STEP 1



PLOT DRIVER: NCDOT\_pdf\_color\_eng\_50.plt  
USER: CHARNDEN  
DATE: 5/31/2019  
TIME: 3:49:00 PM  
FILE: p:\pwhdr\users\01\HDR\_US\_East\_01\Documents\3322\10001377\10082845\6\_0\_CAD\_BITMAP\6.2\_Work\_In\_Progress\R-5812\_TrafficControl\TCP\R5812\_TC\_TMP-14.dgn

REVISIONS

PROJ. REFERENCE NO.	SHEET NO.
R-5812	TMP-14
 HDR Engineering, Inc. of the Carolinas 555 Fayetteville St, Suite 900 Raleigh, N.C. 27601 N.C.B.E.L.S. License Number: F-0116	

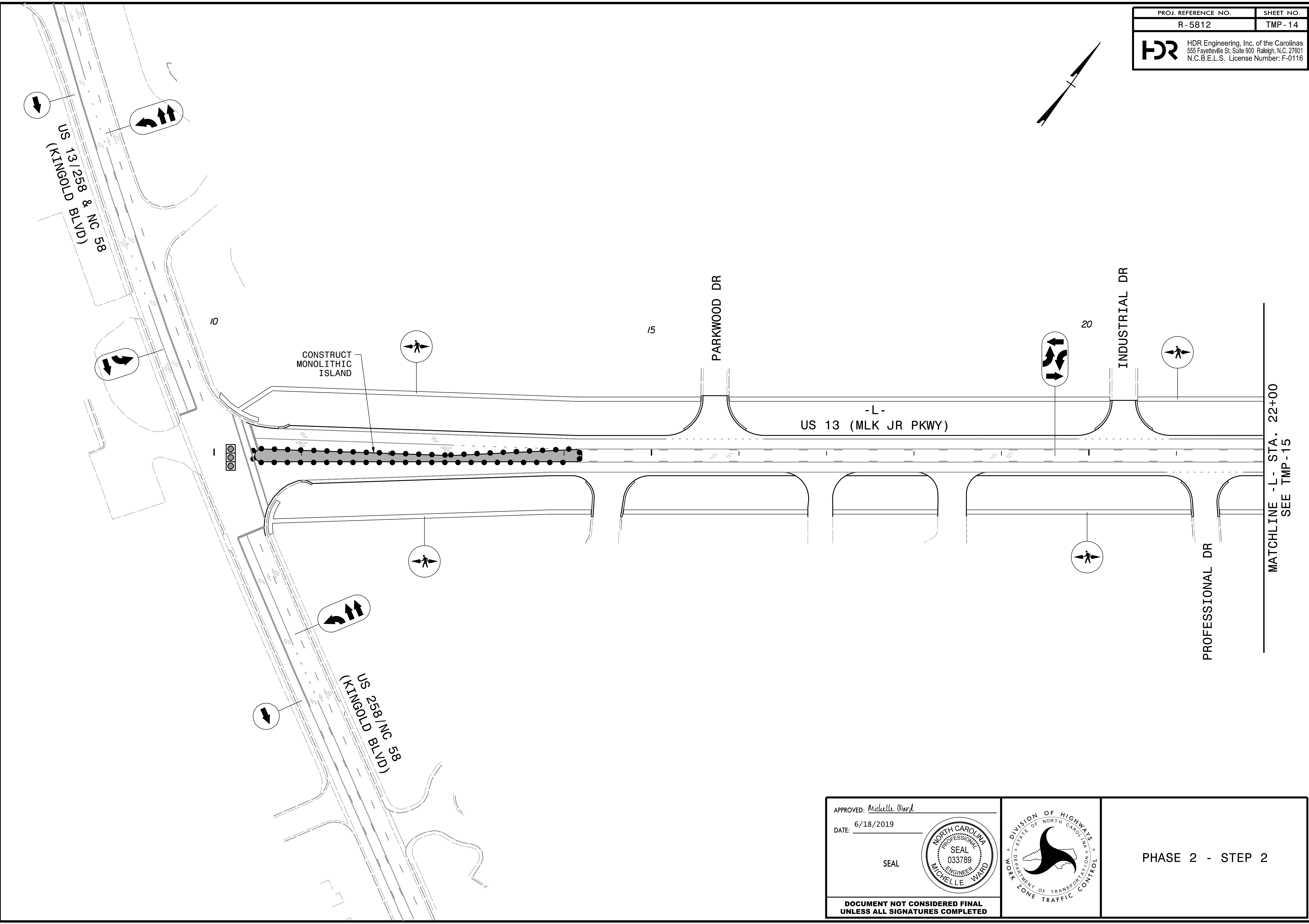
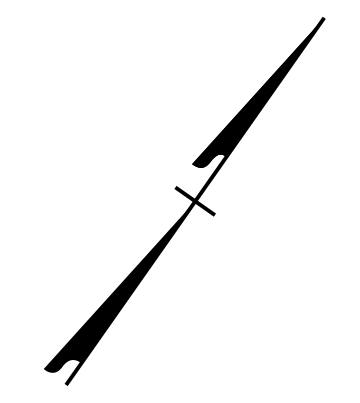

MATCHLINE -L- STA. 22+00  
SEE TMP-15

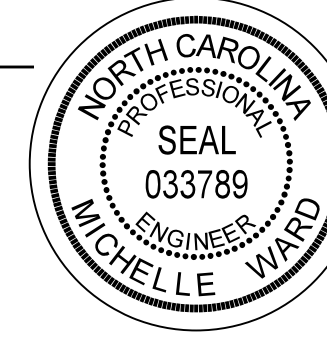
APPROVED: *Michelle Ward*  
 DATE: 6/18/2019  
 SEAL  

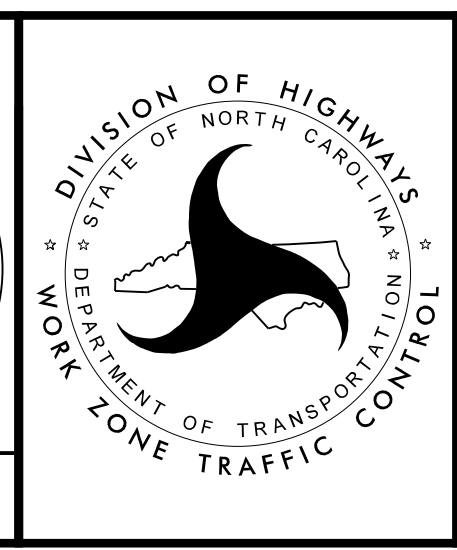

PHASE 2 - STEP 2

DOCUMENT NOT CONSIDERED FINAL  
UNLESS ALL SIGNATURES COMPLETED

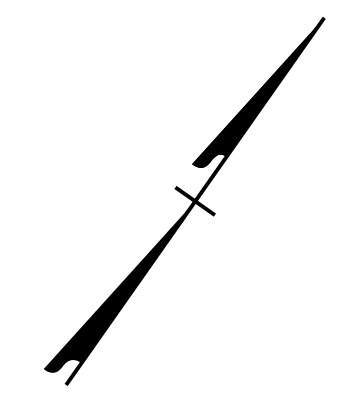

PLACE TEMPORARY MARKINGS IN THE FINAL PATTERN ALONG -Y1-

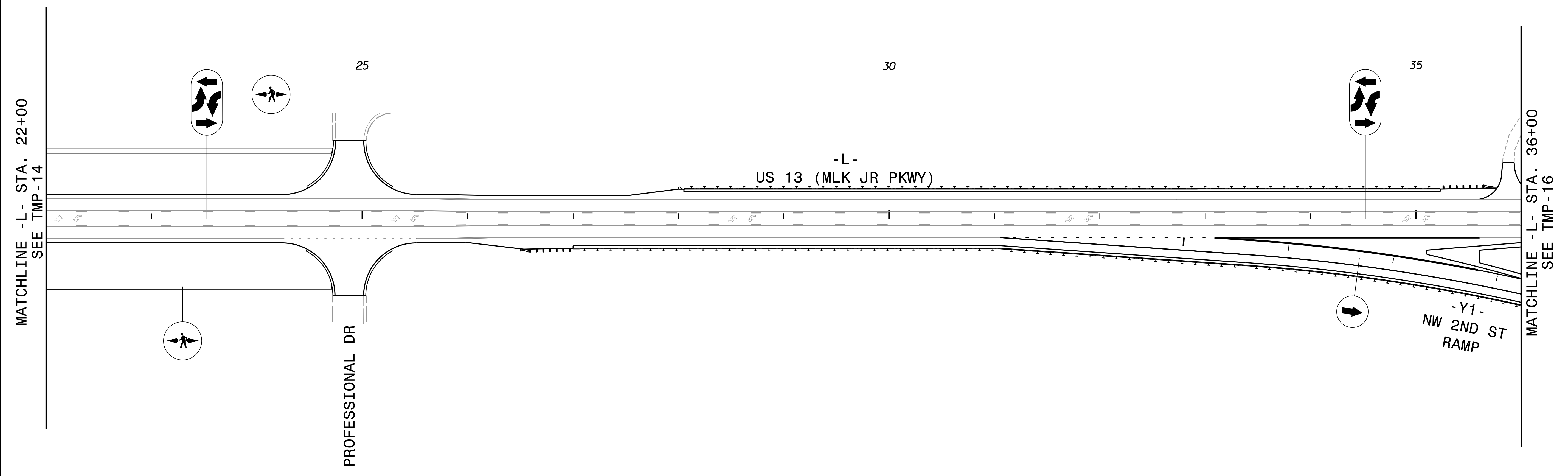

PLOT DRIVER: NCDOT\_pdf\_color\_eng\_50.plt PENTABLE: NCDOT\_tcp.tbl  
 USER: CHARNDEN DATE: 5/31/2019 TIME: 3:49:10 PM  
 FILE: pw:\pwhdr\users\01\HDR\_US\_East\_01\Documents\3322\10001377\10082845\6\_0\_CAD\_BITMAP\6\_2\_Work\_In\_Progress\R-5812\_TrafficControl\TCP\R5812\_TC\_TMP-15.dgn

REVISIONS

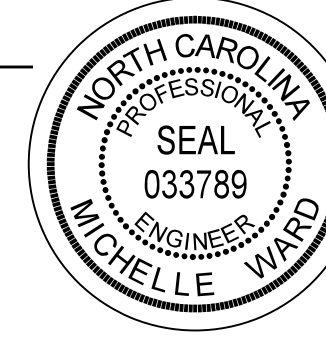
APPROVED: *Michelle Ward*  
 DATE: 6/18/2019  
 SEAL  



PHASE 2 - STEP 2

DOCUMENT NOT CONSIDERED FINAL UNLESS ALL SIGNATURES COMPLETED

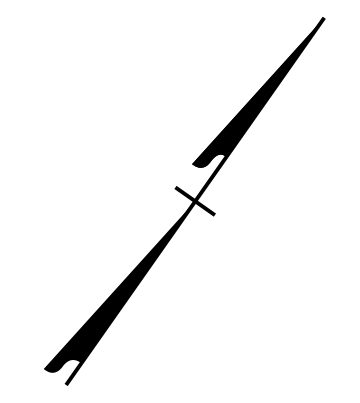

PLACE TEMPORARY MARKINGS IN THE FINAL PATTERN ALONG -Y1-

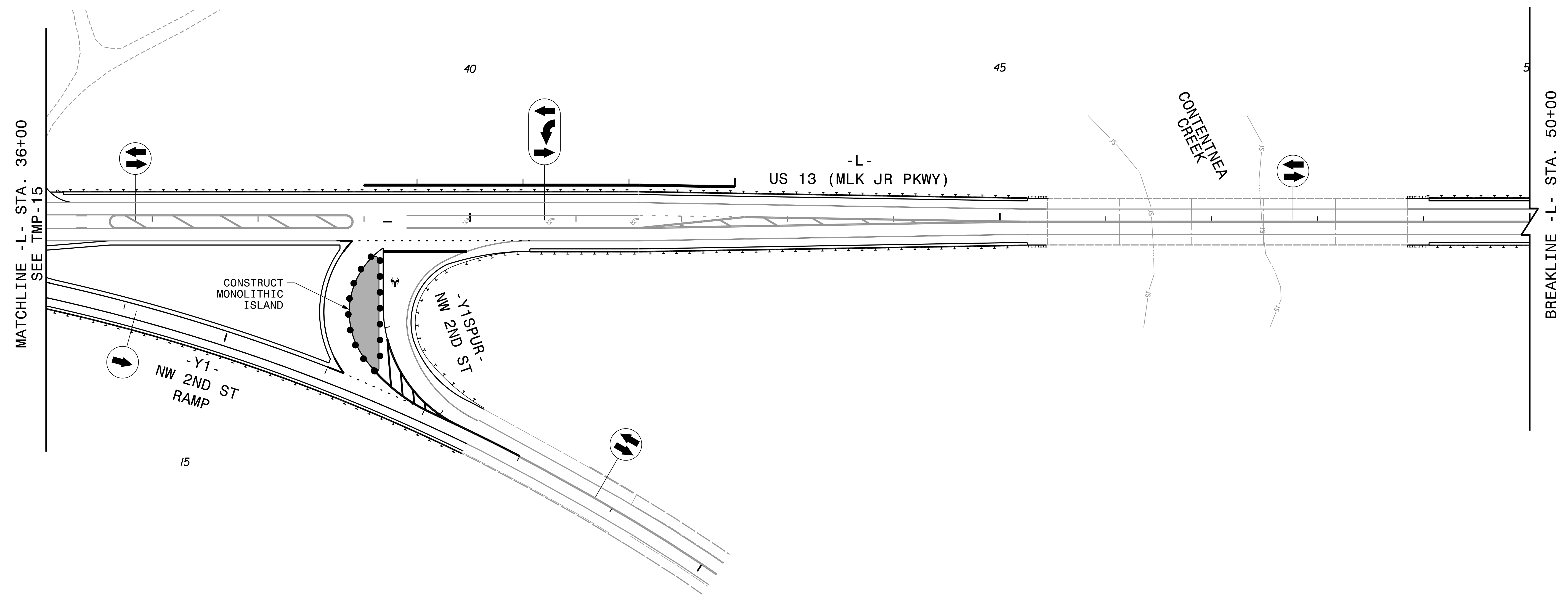

PLOT DRIVER: NCDOT\_pdf\_color\_eng\_50.plt  
 USER: CHARNDEN  
 DATE: 5/31/2019  
 TIME: 3:49:21 PM  
 FILE: p:\p\h\p\uses01\HDR\_US\_East\_01\Documents\3322\10001377\10082845\6\_0\_CAD\_BITMAP\6\_2\_Work\_In\_Progress\R-5812\_TrafficControl\TCP\R5812\_TC\_TMP-16.dgn

REVISIONS

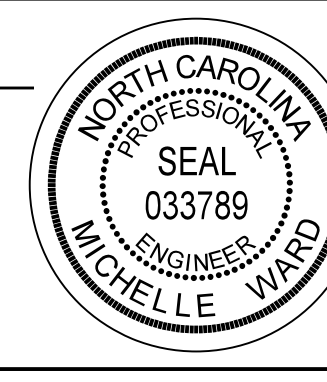
APPROVED: *Michelle Ward*  
 DATE: 6/18/2019  
 SEAL  

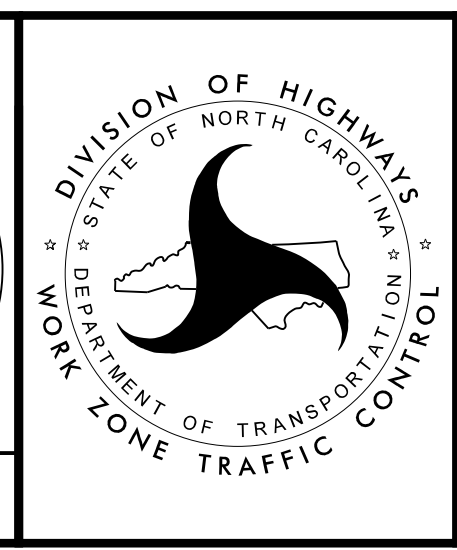

PHASE 2 - STEP 2

DOCUMENT NOT CONSIDERED FINAL UNLESS ALL SIGNATURES COMPLETED