

**This electronic collection of documents is provided
for the convenience of the user
and is Not a Certified Document –**

**The documents contained herein were originally issued
and sealed by the individuals whose names and license
numbers appear on each page, on the dates appearing
with their signature on that page.**

**This file or an individual page
shall not be considered a certified document.**

TIP NO.	SHEET NO.
I - 4400C	PMP - 1
APPROVED: <u>Andrew D. Klinksiek</u> <small>E3078FB4596E44B</small>	
DATE: 6/7/2019	
	
DOCUMENT NOT CONSIDERED FINAL UNLESS ALL SIGNATURES COMPLETED	

**STATE OF NORTH CAROLINA
DEPARTMENT OF TRANSPORTATION**

**PAVEMENT MARKING PLAN
HENDERSON/BUNCOMBE COUNTIES**

T.I.P.: I-4400C

CONTRACT: C204265

INDEX

SHEET NO.	DESCRIPTION
PMP - 1	PAVEMENT MARKING PLAN TITLE SHEET
PMP - 1A	PAVEMENT MARKING SCHEDULE AND LEGEND
PMP - 2-18	PAVEMENT MARKING DETAILS

ROADWAY STANDARD DRAWING

THE FOLLOWING ROADWAY STANDARDS AS APPEAR IN "ROADWAY STANDARD DRAWINGS" - PROJECT SERVICES UNIT - N.C. DEPARTMENT OF TRANSPORTATION - RALEIGH, N.C., DATED JANUARY 2018 ARE APPLICABLE TO THIS PROJECT AND BY REFERENCE HEREBY ARE CONSIDERED A PART OF THESE PLANS:

STD. NO.	TITLE
1205.01	PAVEMENT MARKINGS - LINE TYPES AND OFFSETS
1205.02	PAVEMENT MARKINGS - TWO-LANE AND MULTILANE ROADWAYS
1205.03	PAVEMENT MARKINGS - EXIT AND ENTRANCE RAMP
1205.04	PAVEMENT MARKINGS - INTERSECTIONS
1205.05	PAVEMENT MARKINGS - TURN LANES
1205.06	PAVEMENT MARKINGS - LANE DROPS
1205.08	PAVEMENT MARKINGS - SYMBOLS AND WORD MESSAGES
1205.09	PAVEMENT MARKINGS - PAINTED ISLANDS
1205.12	PAVEMENT MARKINGS - BRIDGES
1205.13	PAVEMENT MARKINGS - LANE REDUCTIONS
1250.01	RAISED PAVEMENT MARKERS - INSTALLATION SPACING
1251.01	RAISED PAVEMENT MARKERS - PERMANENT AND TEMPORARY
1253.01	RAISED PAVEMENT MARKERS - SNOWPLOWABLE
1261.01	GUARDRAIL AND BARRIER DELINEATORS - INSTALLATION SPACING
1261.02	GUARDRAIL AND BARRIER DELINEATORS - TYPES AND MOUNTING
1262.01	GUARDRAIL END DELINEATION

GENERAL NOTES

THE FOLLOWING GENERAL NOTES APPLY AT ALL TIMES FOR THE DURATION OF THE CONSTRUCTION PROJECT, EXCEPT WHEN OTHERWISE NOTED IN THE PLAN, OR DIRECTED BY THE ENGINEER.

A) INSTALL PAVEMENT MARKINGS AND PAVEMENT MARKERS ON THE FINAL SURFACE AS FOLLOWS:

ROAD NAME	MARKING	MARKER
-L- I-26/US 74	POLYUREA	SNOWPLOWABLE
-L- I-26/US 25/US 74	POLYUREA	SNOWPLOWABLE
-Y- LINES	POLYUREA	SNOWPLOWABLE
CONCRETE BRIDGE DECKS	POLYUREA	RAISED

B) TIE PROPOSED PAVEMENT MARKING LINES TO EXISTING PAVEMENT MARKING LINES.

C) REMOVE/REPLACE ANY CONFLICTING/DAMAGED PAVEMENT MARKINGS AND MARKERS.

D) PASSING ZONES WILL BE DETERMINED IN THE FIELD AND MUST BE APPROVED BY THE ENGINEER.

E) STOP BAR LOCATION AT NON-SIGNALIZED INTERSECTIONS MAY BE ADJUSTED AS DIRECTED BY THE ENGINEER.

F) REMOVE ALL RESIDUE AND SURFACE LAITANCE BY ACCEPTABLE METHODS ON CONCRETE BRIDGE DECKS PRIOR TO PLACING POLYUREA PAVEMENT MARKING MATERIAL.

G) UNLESS OTHERWISE SPECIFIED, HEATED-IN-PLACE THERMOPLASTIC MAY BE USED IN LIEU OF EXTRUDED THERMOPLASTIC FOR STOP BARS, SYMBOLS, CHARACTERS AND DIAGONALS. IF HEATED-IN-PLACE IS USED, IT SHALL BE PAID FOR USING THE EXTRUDED THERMOPLASTIC PAY ITEM.

H) SEE ROADWAY PLANS FOR ALTERNATE CURB RAMP DESIGNS WHEN INDICATED ON PAVEMENT MARKING DETAIL SHEETS.

PLANS REVIEWED BY: N.C.D.O.T. SIGNING AND DELINEATION UNIT

<u>Anna G. Henderson, PE</u>	DIVISION 13 TRAFFIC ENGINEER
<u>Steven Buchanan</u>	DIVISION 13 TRAFFIC ENGINEER
<u>Scott M. Collier, PE</u>	REGIONAL TRAFFIC SAFETY ENGINEER
<u>Kelvin Jordan</u>	WESTERN SIGNING AND DELINEATION ENGINEER, DIVISIONS 7, 09-14

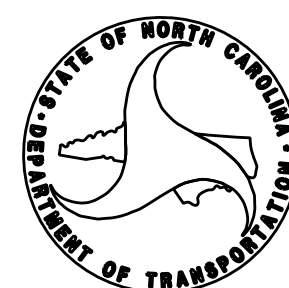

PLAN PREPARED BY: HNTB NORTH CAROLINA, P.C.

<u>A.D. Klinksiek, PE, PTOE</u>	PROJECT ENGINEER
<u>Jenifer Phillips</u>	DESIGN TECHNICIAN

HNTB HNTB NORTH CAROLINA, P.C.
343 E. Six Forks Road, Suite 200
Raleigh, North Carolina 27609
NC License No: C-1554
(919) 546-8997

TIP NO. I - 4400C	SHEET NO. PMP - 1A
APPROVED: <i>Andrew D. Klinck</i> <small>E3078F8459E44B</small>	
DATE: 6/7/2019	
	
DOCUMENT NOT CONSIDERED FINAL UNLESS ALL SIGNATURES COMPLETED	

FINAL PAVEMENT MARKING SCHEDULE

MATERIAL	SYMBOL	DESCRIPTION
PAVEMENT MARKING		
POLYUREA (4", 20 MILS)		
	V8	2 FT. -6 FT. /SP WHITE MINISKIP
	V9	2 FT. -6 FT. /SP YELLOW MINISKIP
	VA	WHITE EDGELINE
	VB	YELLOW EDGELINE
	VC	10 FT. WHITE SKIP
	VD	3 FT. -9 FT. /SP WHITE MINISKIP
	VE	WHITE SOLID LANE LINE
	VI	YELLOW DOUBLE CENTER
POLYUREA (6", 20 MILS)		
	V6	WHITE EDGELINE
	V7	YELLOW EDGELINE
	VJ	10 FT. WHITE SKIP
	VK	3 FT. -9 FT. /SP WHITE MINISKIP
	VL	WHITE SOLID LANE LINE
POLYUREA (8", 20 MILS)		
	V13	3 FT. -9 FT. /SP WHITE MINISKIP
	VN	WHITE GORELINE
	VR	WHITE SOLID LANE LINE
POLYUREA (12", 20 MILS)		
	VS	WHITE GORELINE
	VT	WHITE SOLID LANE LINE
	V14	3 FT. -9 FT. /SP WHITE MINISKIP
THERMOPLASTIC (8", 90 MILS)		
	TO	WHITE DIAGONAL
	TP	YELLOW DIAGONAL
THERMOPLASTIC (12", 90 MILS)		
	TU	WHITE DIAGONAL
	TV	YELLOW DIAGONAL
THERMOPLASTIC (24", 90 MILS)		
	T2	WHITE STOPBAR
THERMOPLASTIC PAVEMENT MARKING SYMBOLS (90 MILS)		
	UA	LEFT TURN ARROW
	UB	RIGHT TURN ARROW
	UC	STRAIGHT ARROW
	UE	COMBO RIGHT/STRAIGHT
	UN	24" YIELD LINE TRIANGLE
	UP	MERGE ARROW
	UQ	RAMP ARROW
	UT	U-TURN ARROW
THERMOPLASTIC PAVEMENT MARKING CHARACTER (90 MILS)		
	UI	ALPHANUMERIC CHAR.
RAISED PAVEMENT MARKERS (NOT SHOWN)		
	MA	YELLOW & YELLOW
	MB	CRYSTAL & RED
SNOWPLOWABLE PAVEMENT MARKERS (NOT SHOWN)		
	ME	YELLOW & YELLOW
	MF	CRYSTAL & RED

LEGEND

GENERAL

- DIRECTION OF TRAFFIC FLOW
- NORTH ARROW
- PROPOSED PVMT. EXIST. PVMT.

PAVEMENT MARKINGS

- PAVEMENT MARKING SYMBOLS
- ONLY PAVEMENT MARKING CHARACTERS

PAVEMENT MARKING SYMBOLS			
	UA	ONLY	UI
	UB		UN
	UC		UP
	UE		UQ
			UT

6/6/2019 10:40:00 AM C:\ADD\4400C_PMP_pmp_01-01A.dgn HNTB

TIP NO. I - 4400C	SHEET NO. PMP - 2
APPROVED: <i>Andrew D. Klinck</i> <small>E3078F8459E44B</small>	
DATE: 6/7/2019	
	
DOCUMENT NOT CONSIDERED FINAL UNLESS ALL SIGNATURES COMPLETED	

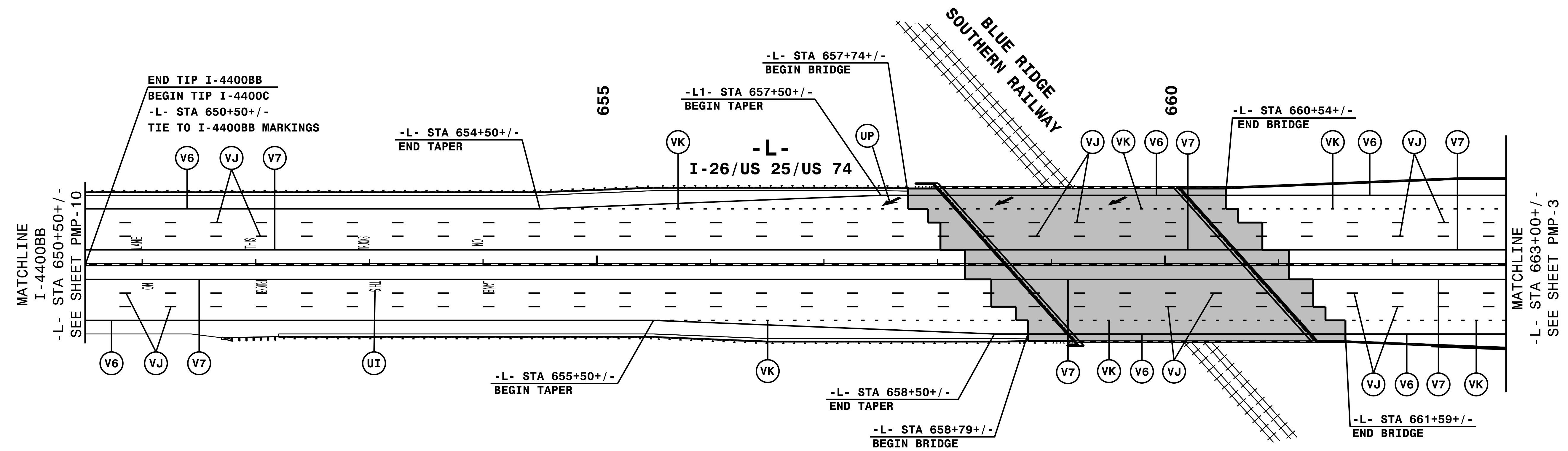

NOTE: ALL LANE WIDTHS ARE 12' UNLESS OTHERWISE SHOWN.

HNTB

HNTB NORTH CAROLINA, P.C.
343 E. Six Forks Road, Suite 200
Raleigh, North Carolina 27609
NC License No: C-1554
(919) 546-8997

PAVEMENT MARKING DETAIL

6/6/2019
6:\PMP\CADD\4400C_PMP_pmp2.dgn
HNTB

TIP NO. I - 4400C	SHEET NO. PMP - 3
APPROVED: <i>Andrew D. Klinck</i> <small>E3078F8459E44B</small>	
DATE: 6/7/2019	
	
DOCUMENT NOT CONSIDERED FINAL UNLESS ALL SIGNATURES COMPLETED	

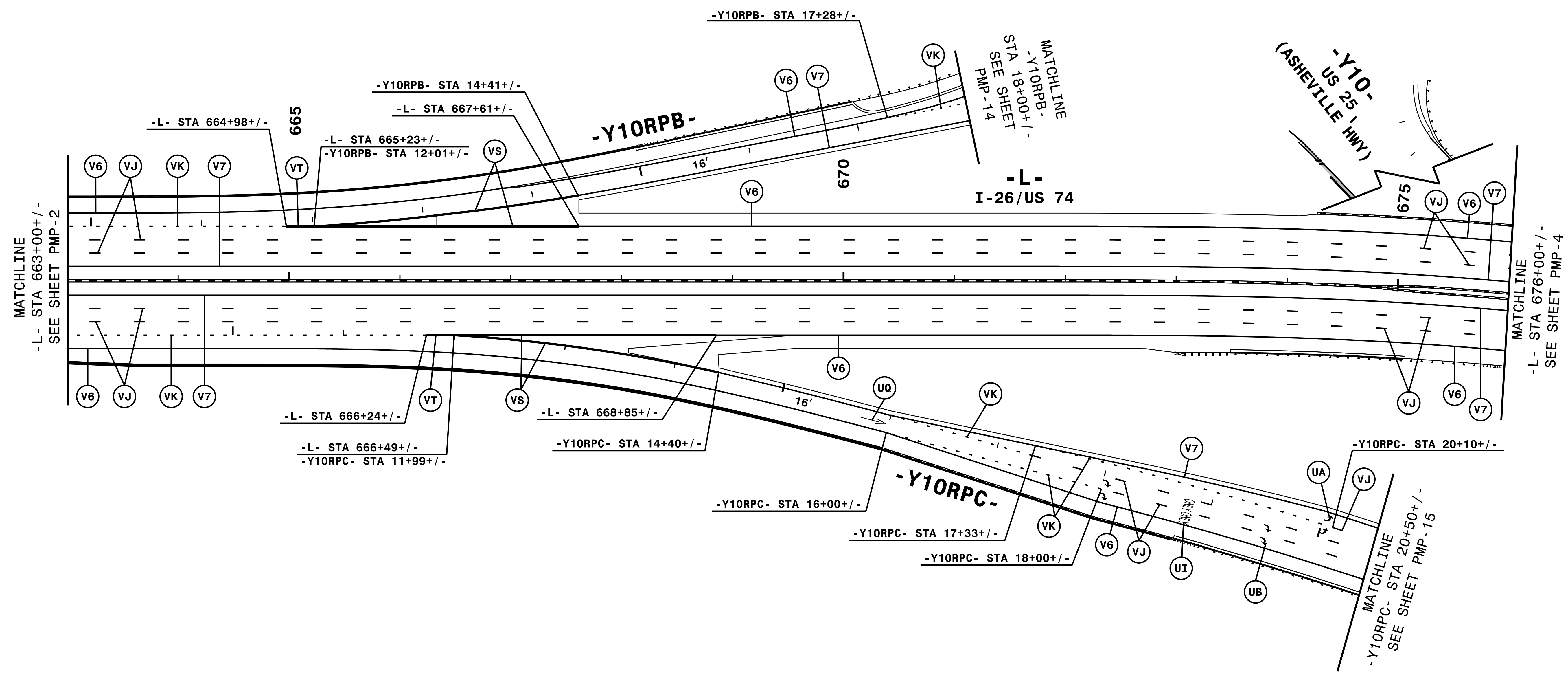

NOTE: ALL LANE WIDTHS ARE 12' UNLESS OTHERWISE SHOWN.

HNTB

HNTB NORTH CAROLINA, P.C.
343 E. Six Forks Road, Suite 200
Raleigh, North Carolina 27609
NC License No: C-1554
(919) 546-8997

PAVEMENT MARKING DETAIL

6/6/2019
P:\PMP\CADD\I4400C_PMP_pmp3.dgn
HNTB

TIP NO. I - 4400C	SHEET NO. PMP - 4
APPROVED: <i>Andrew D. Klinck</i> <small>E3078F8459E44B</small>	
DATE: 6/7/2019	
	
DOCUMENT NOT CONSIDERED FINAL UNLESS ALL SIGNATURES COMPLETED	

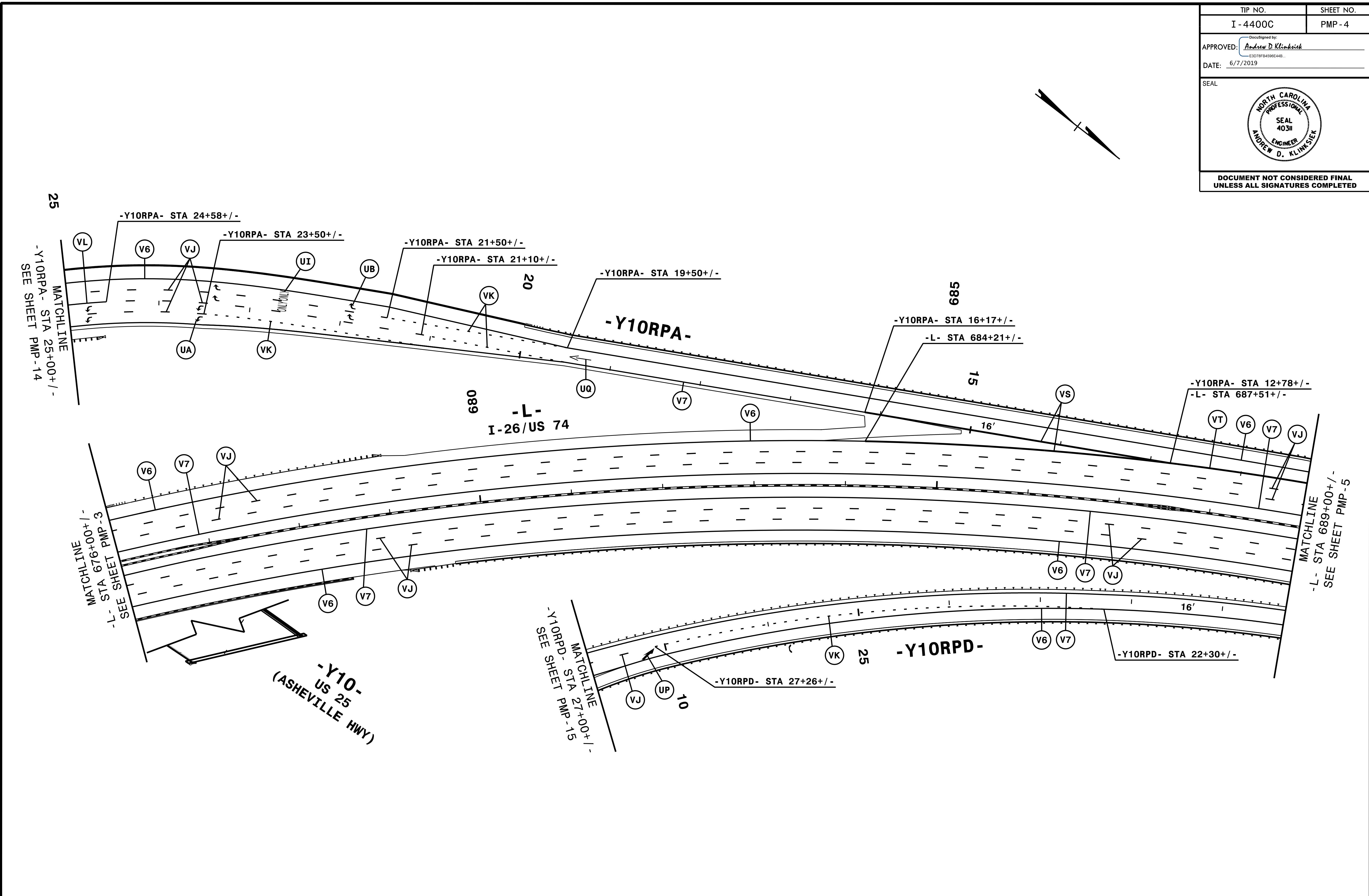

NOTE: ALL LANE WIDTHS ARE 12' UNLESS OTHERWISE SHOWN.

6/6/2019
6:\PMP\CADD\I4400C_PMP_pmp4.dgn
HNTB

HNTB
 HNTB NORTH CAROLINA, P.C.
 343 E. Six Forks Road, Suite 200
 Raleigh, North Carolina 27609
 NC License No: C-1554
 (919) 546-8997

PAVEMENT MARKING DETAIL

TIP NO. I - 4400C	SHEET NO. PMP - 5
APPROVED: <i>Andrew D. Klinck</i> <small>E3078F8459E44B</small>	
DATE: 6/7/2019	
	
DOCUMENT NOT CONSIDERED FINAL UNLESS ALL SIGNATURES COMPLETED	

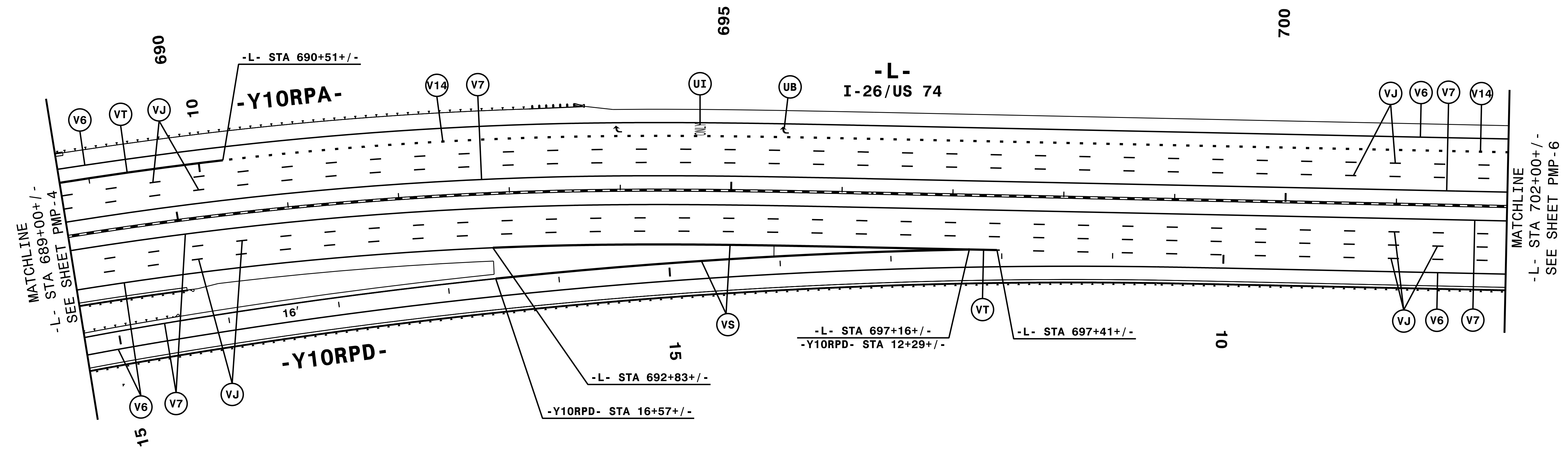
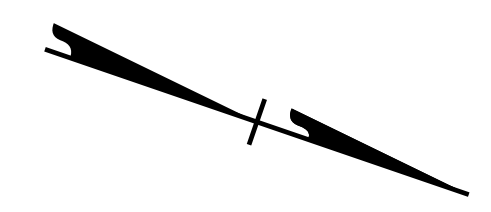

NOTE: ALL LANE WIDTHS ARE 12' UNLESS OTHERWISE SHOWN.

6/6/2019
P:\PMP\CADD\14400C_PMP_pmp5.dgn
HNTB

HNTB
 HNTB NORTH CAROLINA, P.C.
 343 E. SIX FORKS ROAD, SUITE 200
 RALEIGH, NORTH CAROLINA 27609
 NC LICENSE NO: C-1554
 (919) 546-8997

PAVEMENT MARKING DETAIL

TIP NO. I - 4400C	SHEET NO. PMP - 6
APPROVED: <i>Andrew D. Klinck</i> <small>E3078F8459E44B</small>	
DATE: 6/7/2019	
	
DOCUMENT NOT CONSIDERED FINAL UNLESS ALL SIGNATURES COMPLETED	

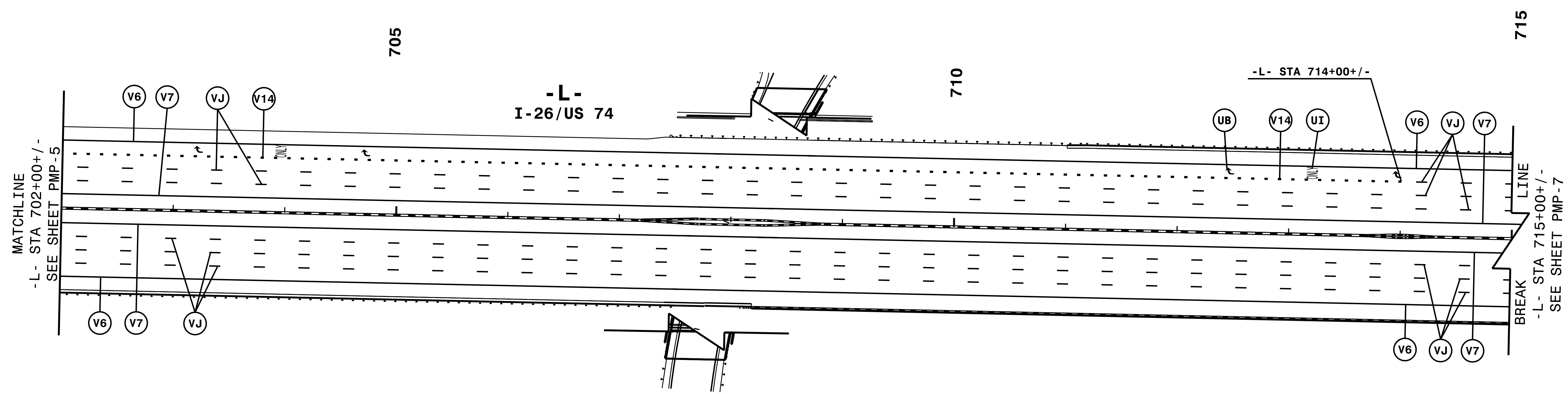

-Y11-
SR 1345
(BUTLER BRIDGE RD)

SEE PMP-17 FOR
-Y11- SR 1345
(BUTLER BRIDGE RD)

NOTE: ALL LANE WIDTHS ARE 12' UNLESS OTHERWISE SHOWN.

HNTB

HNTB NORTH CAROLINA, P.C.
343 E. SIX FORKS ROAD, SUITE 200
RALEIGH, NORTH CAROLINA 27609
NC License No: C-1554
(919) 546-8997

PAVEMENT MARKING DETAIL

6/6/2019
6:\PMP\CADD\4400C_PMP_pmp6.dgn
HNTB

TIP NO. I - 4400C	SHEET NO. PMP - 7
APPROVED: <i>Andrew D. Klinck</i> <small>E3078F8459E44B</small>	
DATE: 6/7/2019	
	
DOCUMENT NOT CONSIDERED FINAL UNLESS ALL SIGNATURES COMPLETED	

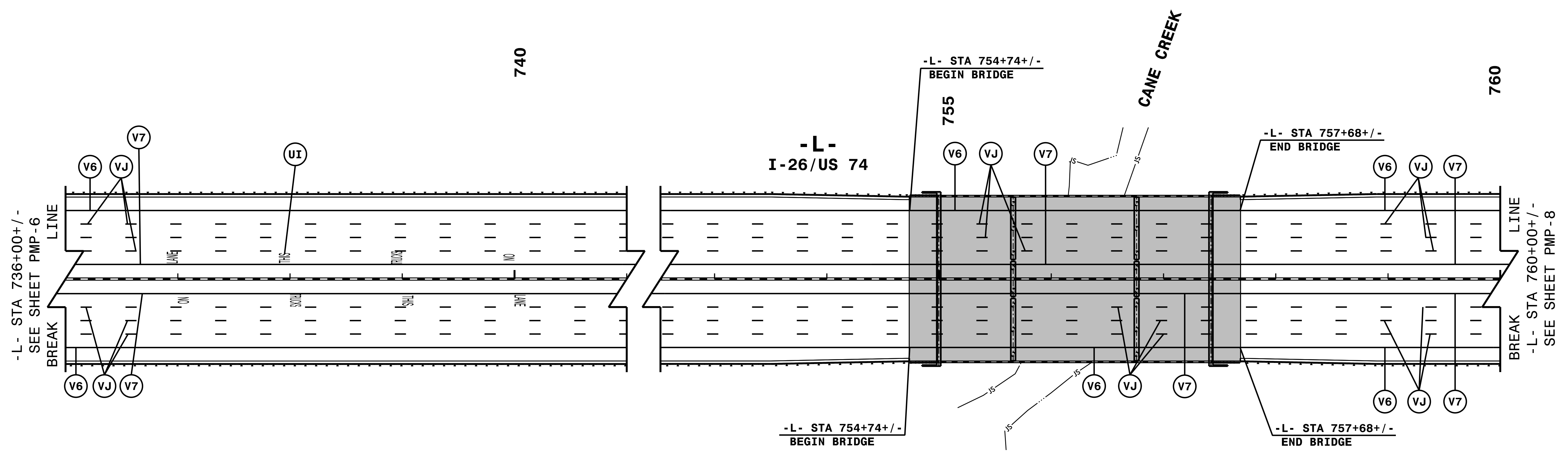

NOTE: ALL LANE WIDTHS ARE 12' UNLESS OTHERWISE SHOWN.

HNTB HNTB NORTH CAROLINA, P.C.
343 E. Six Forks Road, Suite 200
Raleigh, North Carolina 27609
NC License No: C-1554
(919) 546-8997

PAVEMENT MARKING DETAIL

6/6/2019
6:\PMP\CADD\4400C_PMP_pmp7.dgn
HNTB

TIP NO. I - 4400C	SHEET NO. PMP - 8
APPROVED: <i>Andrew D. Klinck</i> <small>E3078F8459E44B</small>	
DATE: 6/7/2019	
	
DOCUMENT NOT CONSIDERED FINAL UNLESS ALL SIGNATURES COMPLETED	

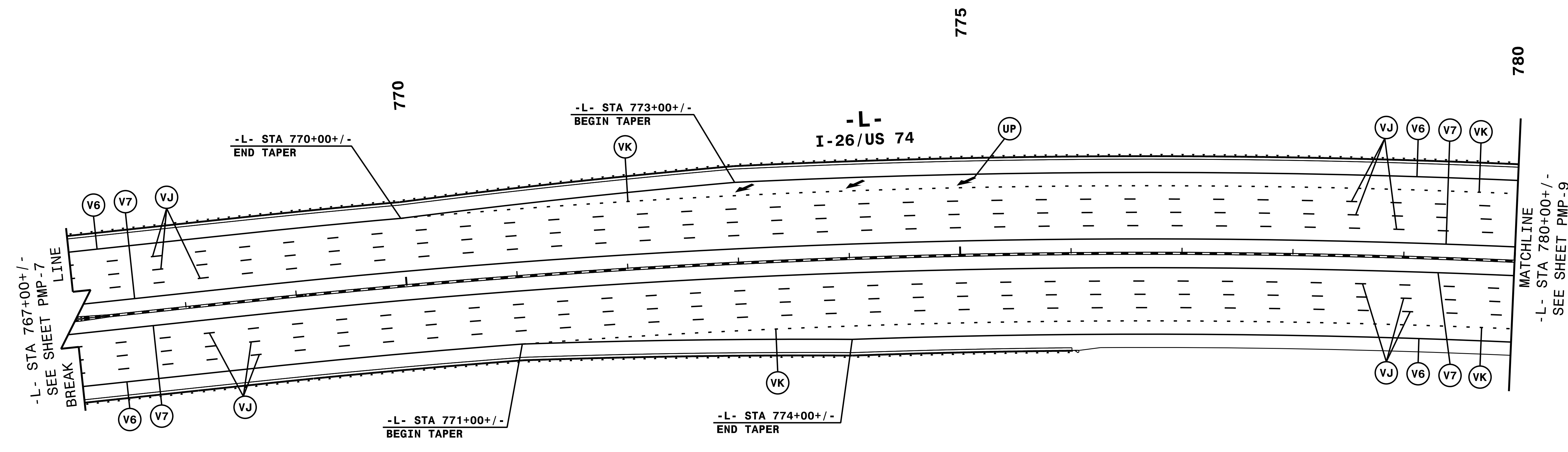

NOTE: ALL LANE WIDTHS ARE 12' UNLESS OTHERWISE SHOWN.

6/6/2019
6:\PMP\CADD\4400C_PMP_pmp8.dgn
HNTB

HNTB
 HNTB NORTH CAROLINA, P.C.
 343 E. SIX FORKS ROAD, SUITE 200
 RALEIGH, NORTH CAROLINA 27609
 NC LICENSE NO: C-1554
 (919) 546-8997

PAVEMENT MARKING DETAIL

TIP NO. I - 4400C	SHEET NO. PMP - 9
APPROVED: <i>Andrew D. Klinck</i> <small>E3078F8459E44B</small>	
DATE: 6/7/2019	
	
DOCUMENT NOT CONSIDERED FINAL UNLESS ALL SIGNATURES COMPLETED	

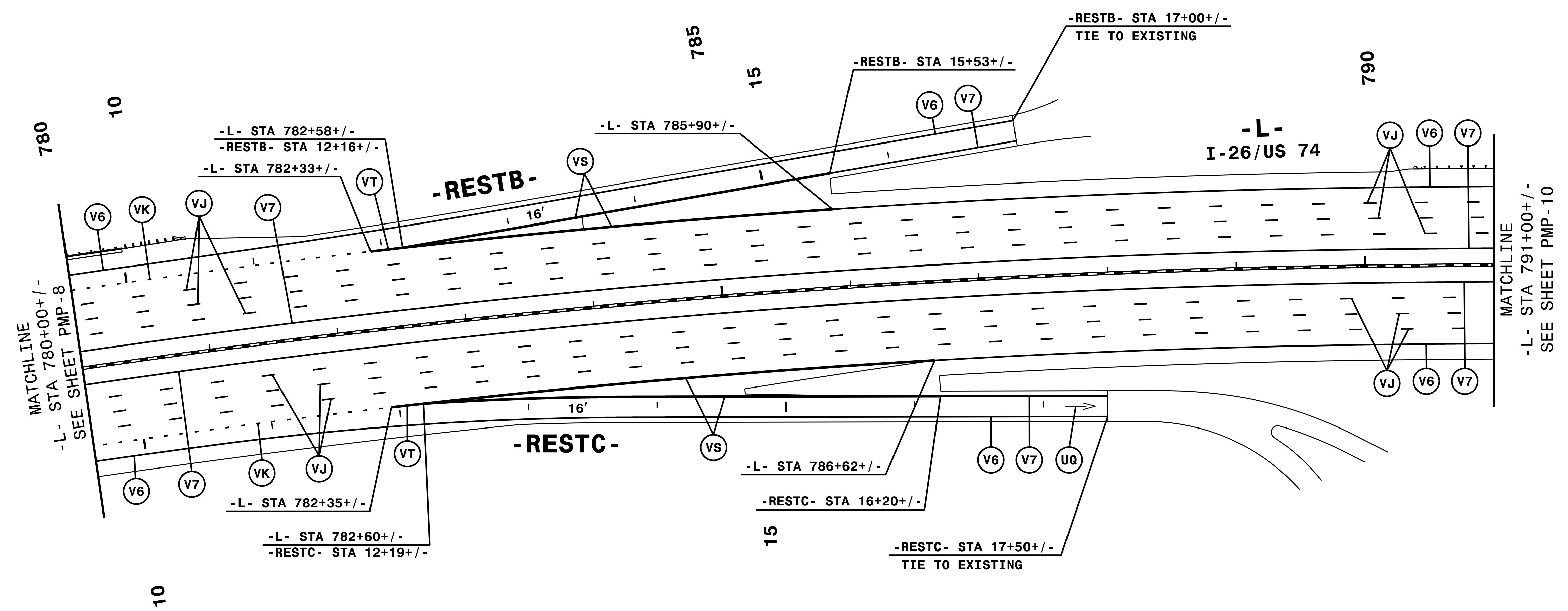

NOTE: ALL LANE WIDTHS ARE 12' UNLESS OTHERWISE SHOWN.

6/6/2019
6:\PMP\CADD\I4400C_PMP_pmp9.dgn
HNTB

HNTB HNTB NORTH CAROLINA, P.C.
343 E. SIX FORKS ROAD, SUITE 200
RALEIGH, NORTH CAROLINA 27609
NC LICENSE NO: C-1554
(919) 546-8997

PAVEMENT MARKING DETAIL

TIP NO. I - 4400C	SHEET NO. PMP - 10
APPROVED: <i>Andrew D. Klinck</i> <small>E3078F8459E44B</small>	
DATE: 6/7/2019	
	
DOCUMENT NOT CONSIDERED FINAL UNLESS ALL SIGNATURES COMPLETED	

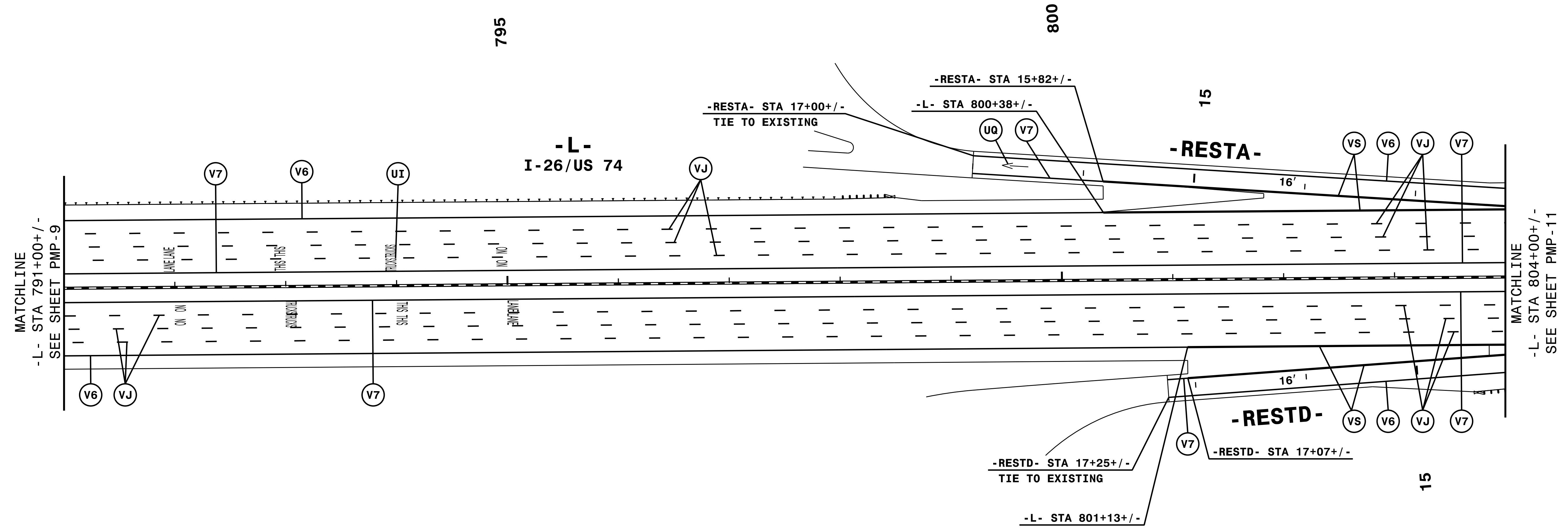

NOTE: ALL LANE WIDTHS ARE 12' UNLESS OTHERWISE SHOWN.

HNTB

HNTB NORTH CAROLINA, P.C.
343 E. SIX FORKS ROAD, SUITE 200
RALEIGH, NORTH CAROLINA 27609
NC License No: C-1554
(919) 546-8997

PAVEMENT MARKING DETAIL

6/6/2019
P:\PMP\CADD\14400C_PMP.pmb\0.dgn
HNTB

TIP NO. I - 4400C	SHEET NO. PMP - 11
APPROVED: <i>Andrew D. Klinck</i> <small>E3078F8459E44B</small>	
DATE: 6/7/2019	
	
DOCUMENT NOT CONSIDERED FINAL UNLESS ALL SIGNATURES COMPLETED	

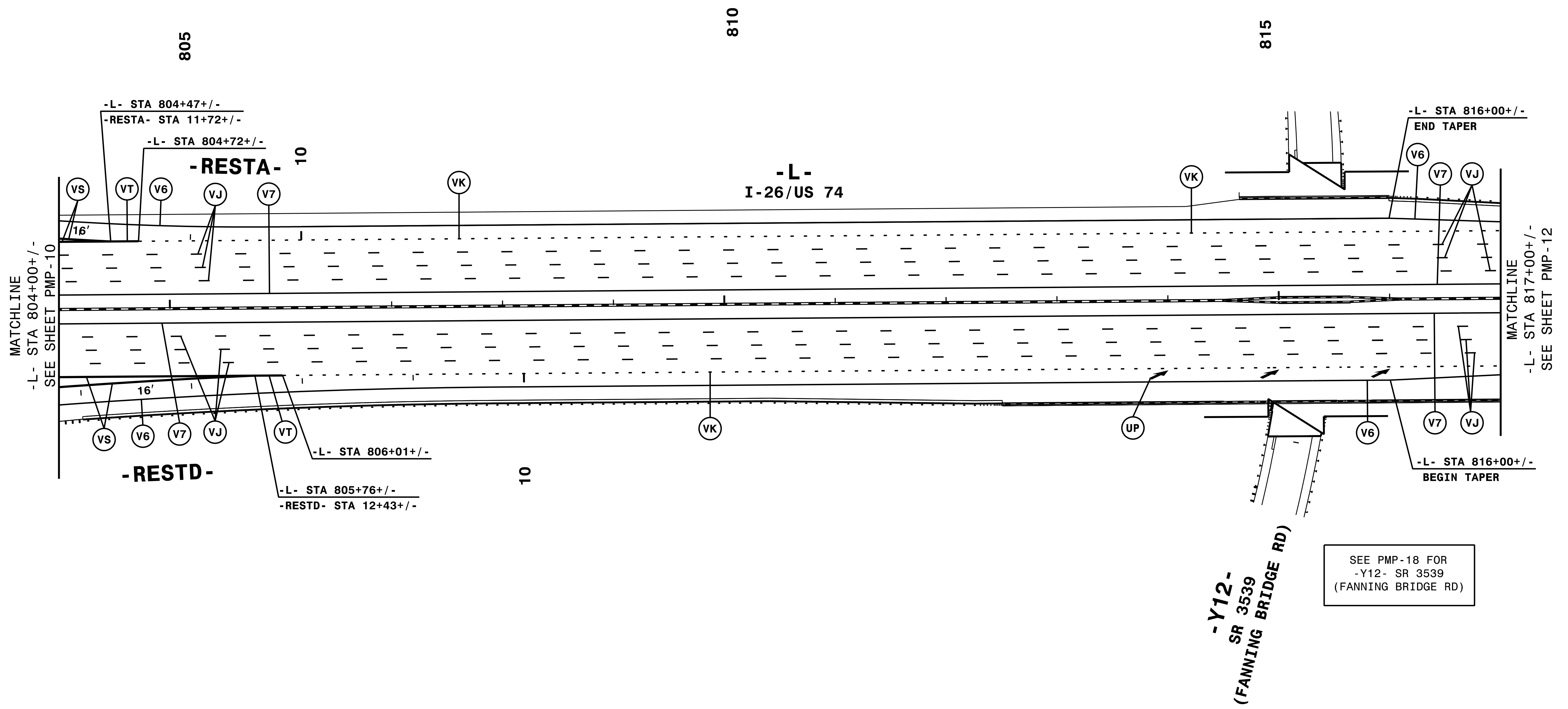

NOTE: ALL LANE WIDTHS ARE 12' UNLESS OTHERWISE SHOWN.

HNTB
HNTB NORTH CAROLINA, P.C.
 343 E. SIX FORKS ROAD, SUITE 200
 RALEIGH, NORTH CAROLINA 27609
 NC LICENSE NO: C-1554
 (919) 546-8997

PAVEMENT MARKING DETAIL

6/6/2019
P:\PMP\CADD\I4400C_PMP_pmbill.dgn
HNTB

TIP NO. I - 4400C	SHEET NO. PMP - 12
APPROVED: <i>Andrew D. Klinck</i> <small>E3078F8459E44B</small>	
DATE: 6/7/2019	
SEAL 	
DOCUMENT NOT CONSIDERED FINAL UNLESS ALL SIGNATURES COMPLETED	

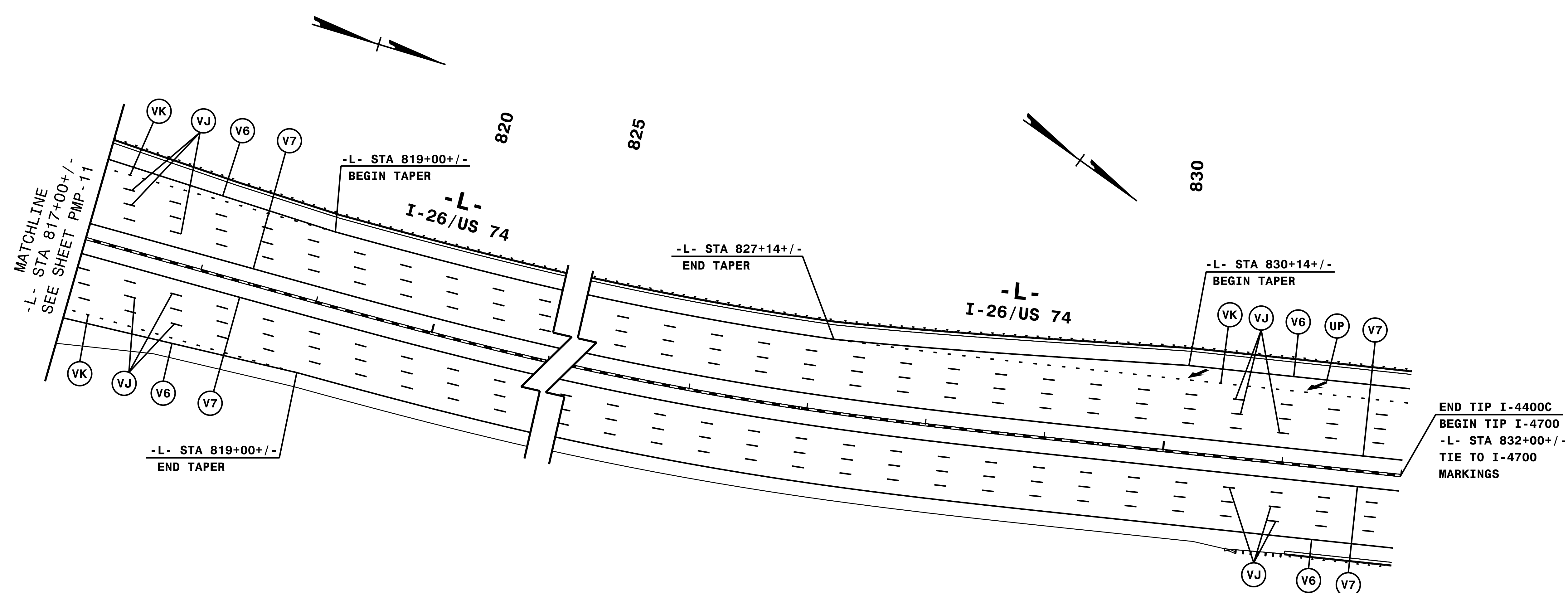

NOTE: ALL LANE WIDTHS ARE 12' UNLESS OTHERWISE SHOWN.

6/6/2019
6:\PMP\CADD\I4400C_PMP_pmp12.dgn
HNTB

HNTB
 HNTB NORTH CAROLINA, P.C.
 343 E. SIX FORKS ROAD, SUITE 200
 RALEIGH, NORTH CAROLINA 27609
 NC LICENSE NO: C-1554
 (919) 546-8997

PAVEMENT MARKING DETAIL

TIP NO. I - 4400C	SHEET NO. PMP - 13
APPROVED: <i>Andrew D. Klinck</i> <small>E3078F8459E44B</small>	
DATE: 6/7/2019	
	
DOCUMENT NOT CONSIDERED FINAL UNLESS ALL SIGNATURES COMPLETED	

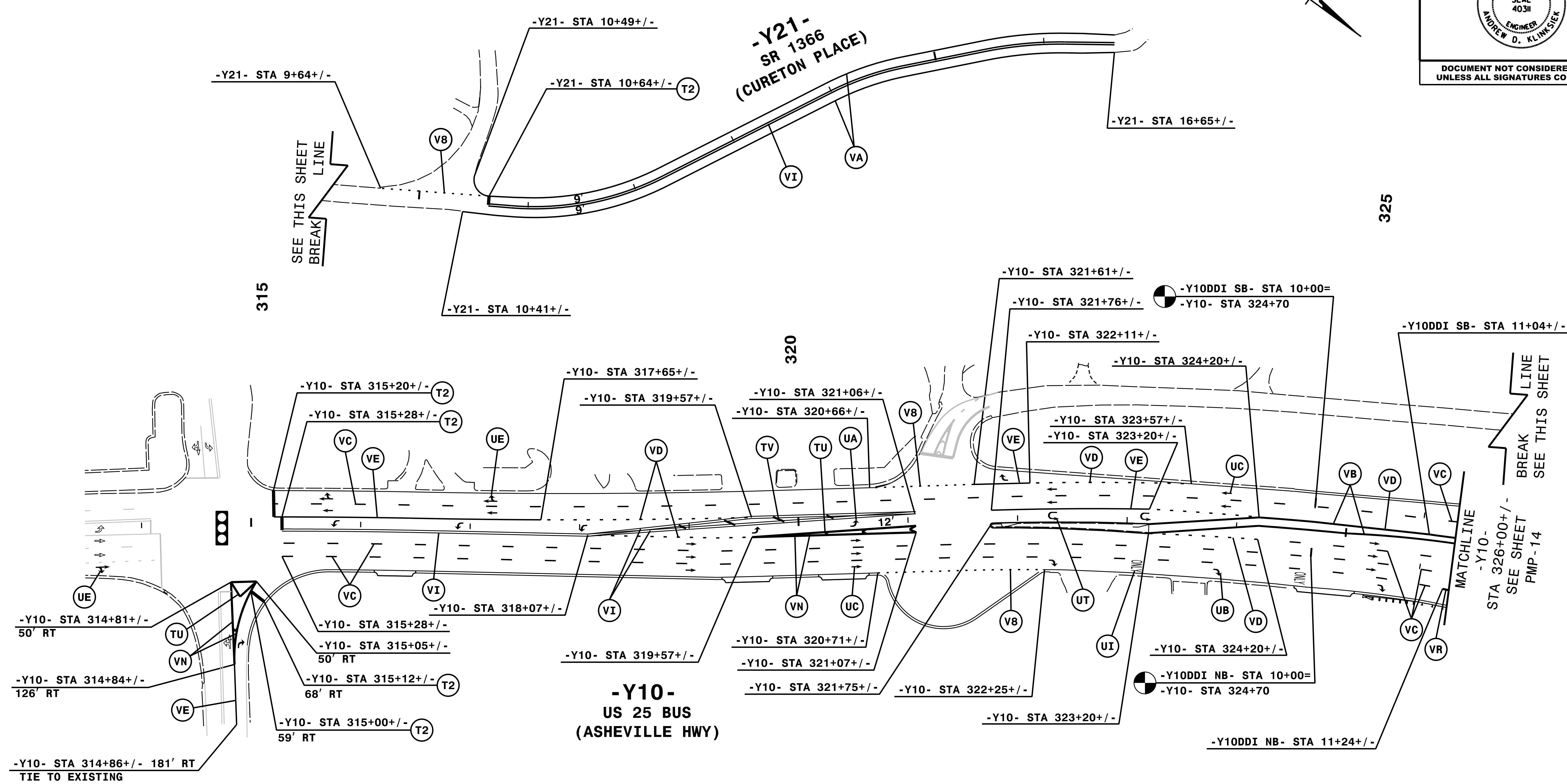

ENGINEER TO APPROVE LOCATION OF ALL UNSIGNALIZED STOPBARS.

NOTE: ALL LANE WIDTHS ARE 12' UNLESS OTHERWISE SHOWN.

HNTB

HNTB NORTH CAROLINA, P.C.
343 E. SIX FORKS ROAD, SUITE 200
RALEIGH, NORTH CAROLINA 27609
NC LICENSE NO: C-1554
(919) 546-8997

PAVEMENT MARKING DETAIL

6/6/2019
 P:\PMP\CADD\4400C_PMP_pmb13.dgn
 HNTB

TIP NO. I - 4400C	SHEET NO. PMP - 15
APPROVED: <i>Andrew D. Klinck</i> E3078F8459E44B	
DATE: 6/7/2019	
	
DOCUMENT NOT CONSIDERED FINAL UNLESS ALL SIGNATURES COMPLETED	

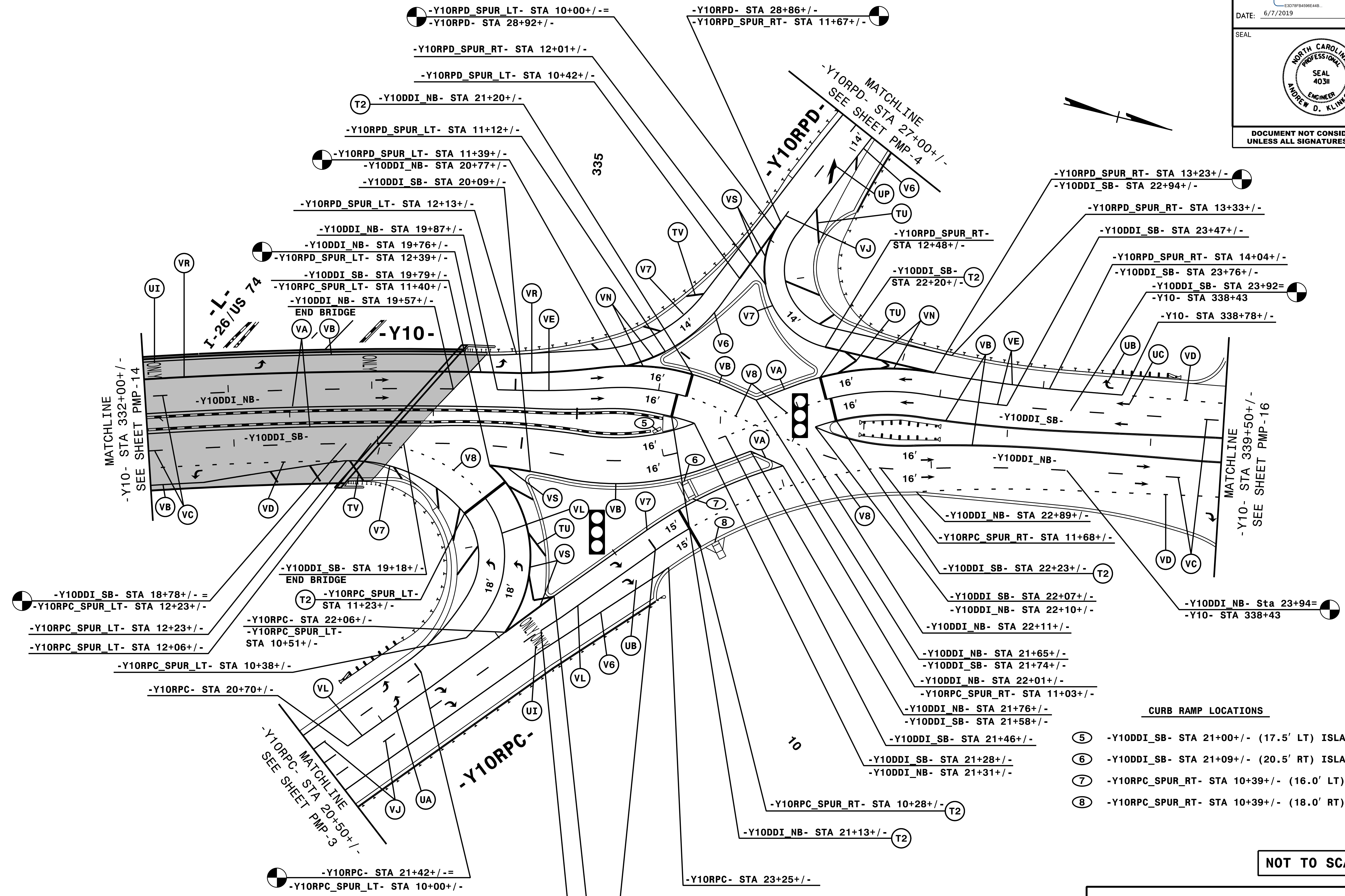

NOTE: ALL LANE WIDTHS ARE 12' UNLESS OTHERWISE SHOWN.

- CURB RAMP LOCATIONS**
- ⑤ -Y10DDI_SB- STA 21+00+/- (17.5' LT) ISLAND
 - ⑥ -Y10DDI_SB- STA 21+09+/- (20.5' RT) ISLAND
 - ⑦ -Y10RPC_SPUR_RT- STA 10+39+/- (16.0' LT) ISLAND
 - ⑧ -Y10RPC_SPUR_RT- STA 10+39+/- (18.0' RT) STANDARD

NOT TO SCALE

HNTB
 HNTB NORTH CAROLINA, P.C.
 343 E. Six Forks Road, Suite 200
 Raleigh, North Carolina 27609
 NC License No: C-1554
 (919) 546-8997

PAVEMENT MARKING DETAIL

6/6/2019
6:\PMP\CADD\4400C_PMP_pmp15.dgn
HNTB

TIP NO. I - 4400C	SHEET NO. PMP - 16
APPROVED: <i>Andrew D. Klinck</i> <small>E3078F8459E44B</small>	
DATE: 6/7/2019	
SEAL 	
DOCUMENT NOT CONSIDERED FINAL UNLESS ALL SIGNATURES COMPLETED	

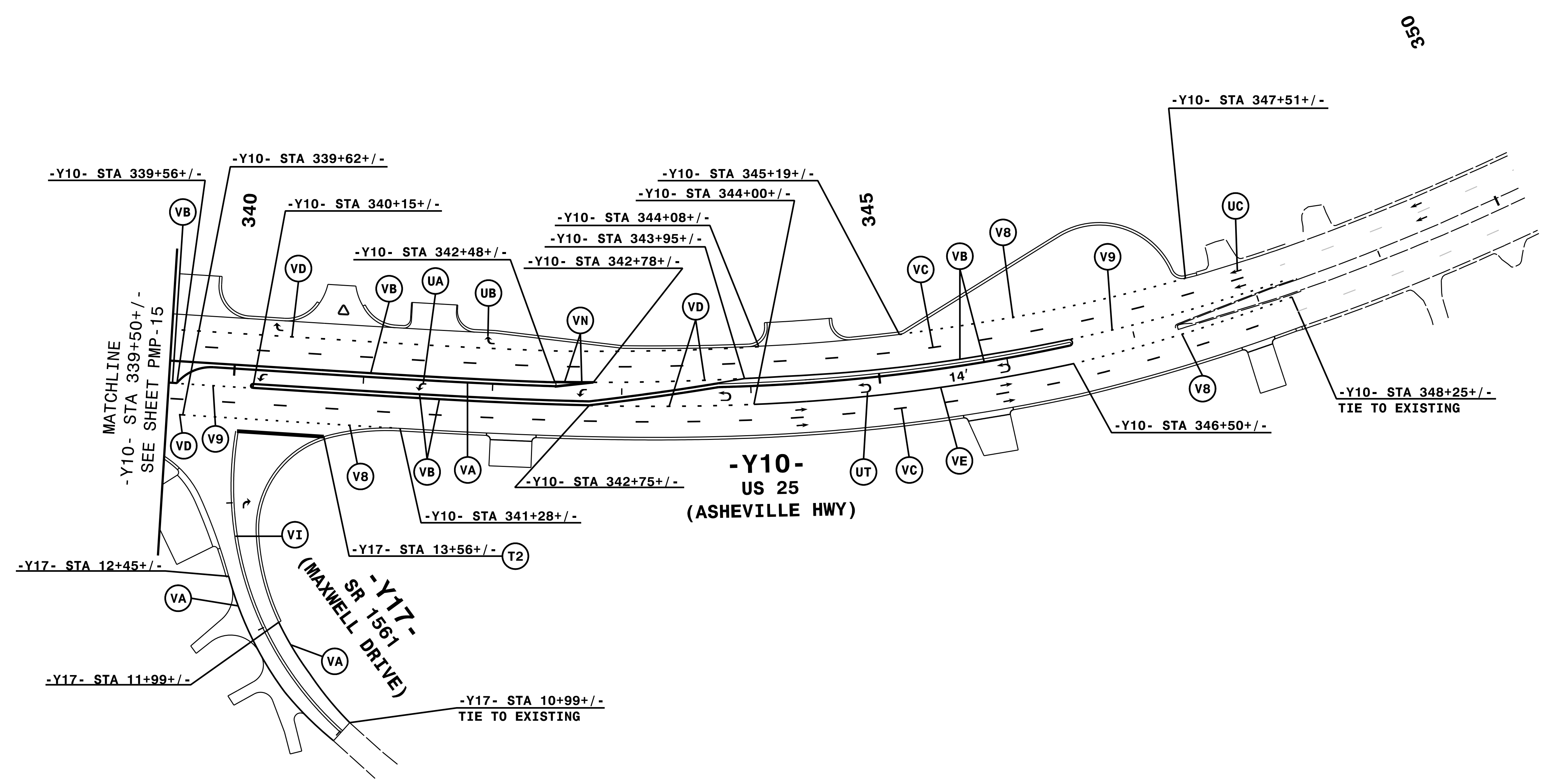

ENGINEER TO APPROVE LOCATION OF ALL UNSIGNALIZED STOPBARS.

NOTE: ALL LANE WIDTHS ARE 12' UNLESS OTHERWISE SHOWN.

HNTB
HNTB NORTH CAROLINA, P.C.
 343 E. SIX FORKS ROAD, SUITE 200
 RALEIGH, NORTH CAROLINA 27609
 NC LICENSE NO: C-1554
 (919) 546-8997

PAVEMENT MARKING DETAIL

6/6/2019
P:\PMP\CADD\I4400C_PMP_pmb\6.dgn
HNTB

TIP NO. I - 4400C	SHEET NO. PMP - 17
APPROVED: <i>Andrew D. Klinck</i> <small>E3078F8459E44B</small>	
DATE: 6/7/2019	
	
DOCUMENT NOT CONSIDERED FINAL UNLESS ALL SIGNATURES COMPLETED	

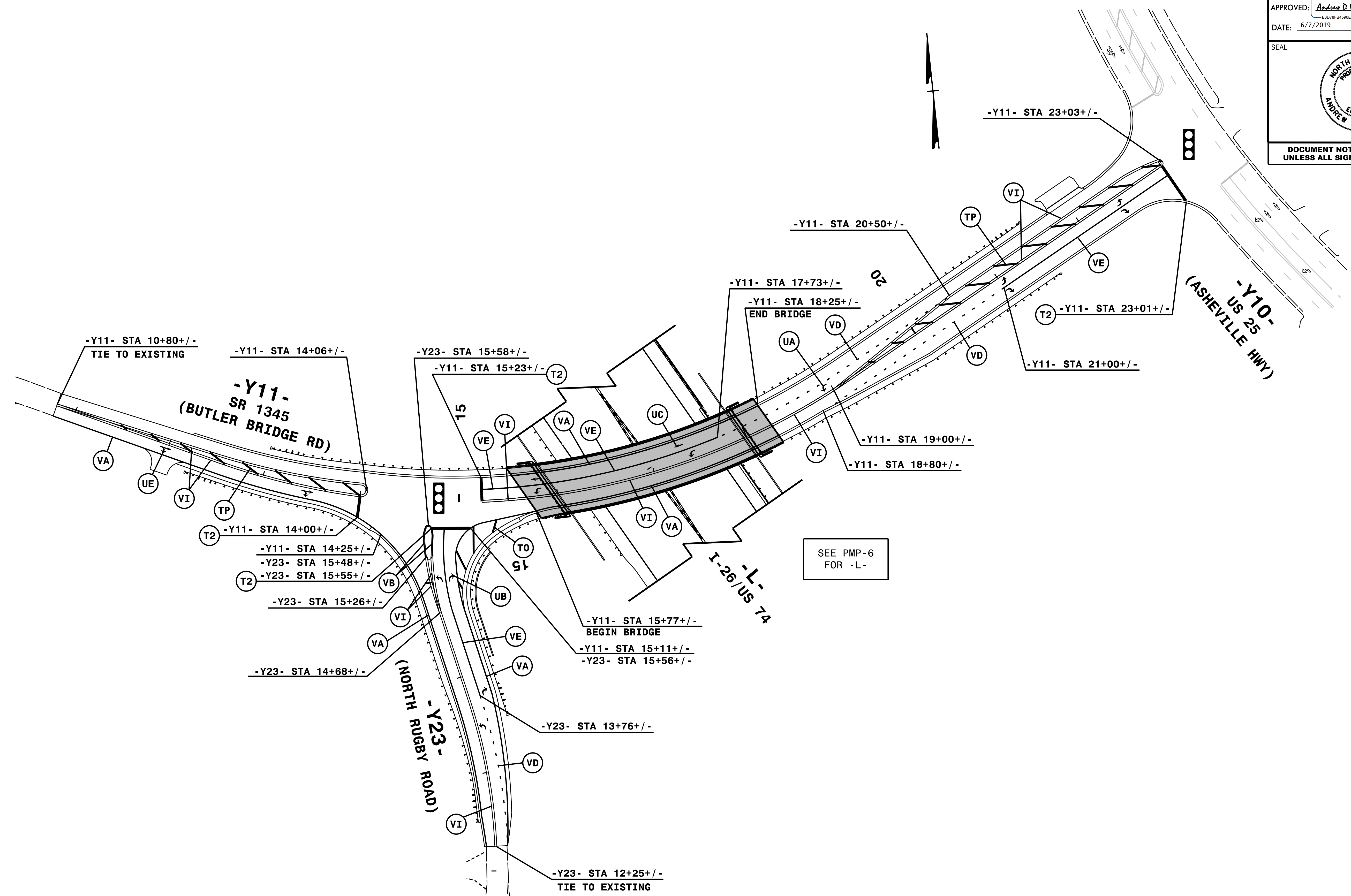

NOTE: ALL LANE WIDTHS ARE 12' UNLESS OTHERWISE SHOWN.

6/6/2019
P:\PMP\CADD\I4400C_PMP_pmb17.dgn
HNTB

HNTB
 HNTB NORTH CAROLINA, P.C.
 343 E. Six Forks Road, Suite 200
 Raleigh, North Carolina 27609
 NC License No: C-1554
 (919) 546-8997

PAVEMENT MARKING DETAIL

TIP NO. I - 4400C	SHEET NO. PMP - 18
APPROVED: <i>Andrew D. Klinck</i> <small>E3078F8459E44B...</small>	
DATE: 6/7/2019	
SEAL 	
DOCUMENT NOT CONSIDERED FINAL UNLESS ALL SIGNATURES COMPLETED	

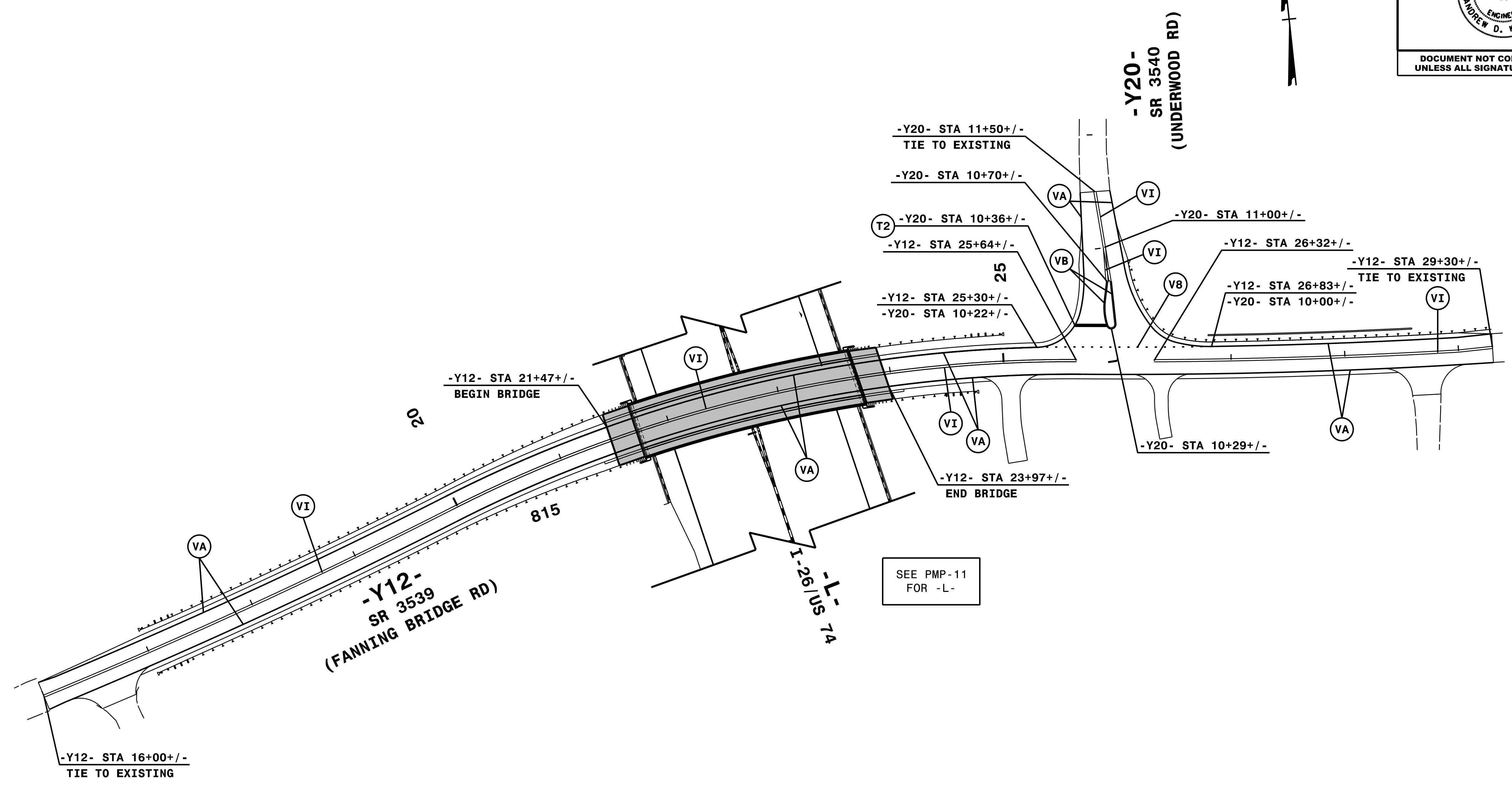

ENGINEER TO APPROVE LOCATION OF ALL UNSIGNALIZED STOPBARS.

NOTE: ALL LANE WIDTHS ARE 12' UNLESS OTHERWISE SHOWN.

HNTB HNTB NORTH CAROLINA, P.C.
343 E. SIX FORKS ROAD, SUITE 200
RALEIGH, NORTH CAROLINA 27609
NC LICENSE NO: C-1554
(919) 546-8997

PAVEMENT MARKING DETAIL

6/6/2019
P:\PMP\CADD\14400C_PMP_pmb18.dgn
HNTB