

**This electronic collection of documents is provided
for the convenience of the user
and is Not a Certified Document –**

**The documents contained herein were originally issued
and sealed by the individuals whose names and license
numbers appear on each page, on the dates appearing
with their signature on that page.**

**This file or an individual page
shall not be considered a certified document.**

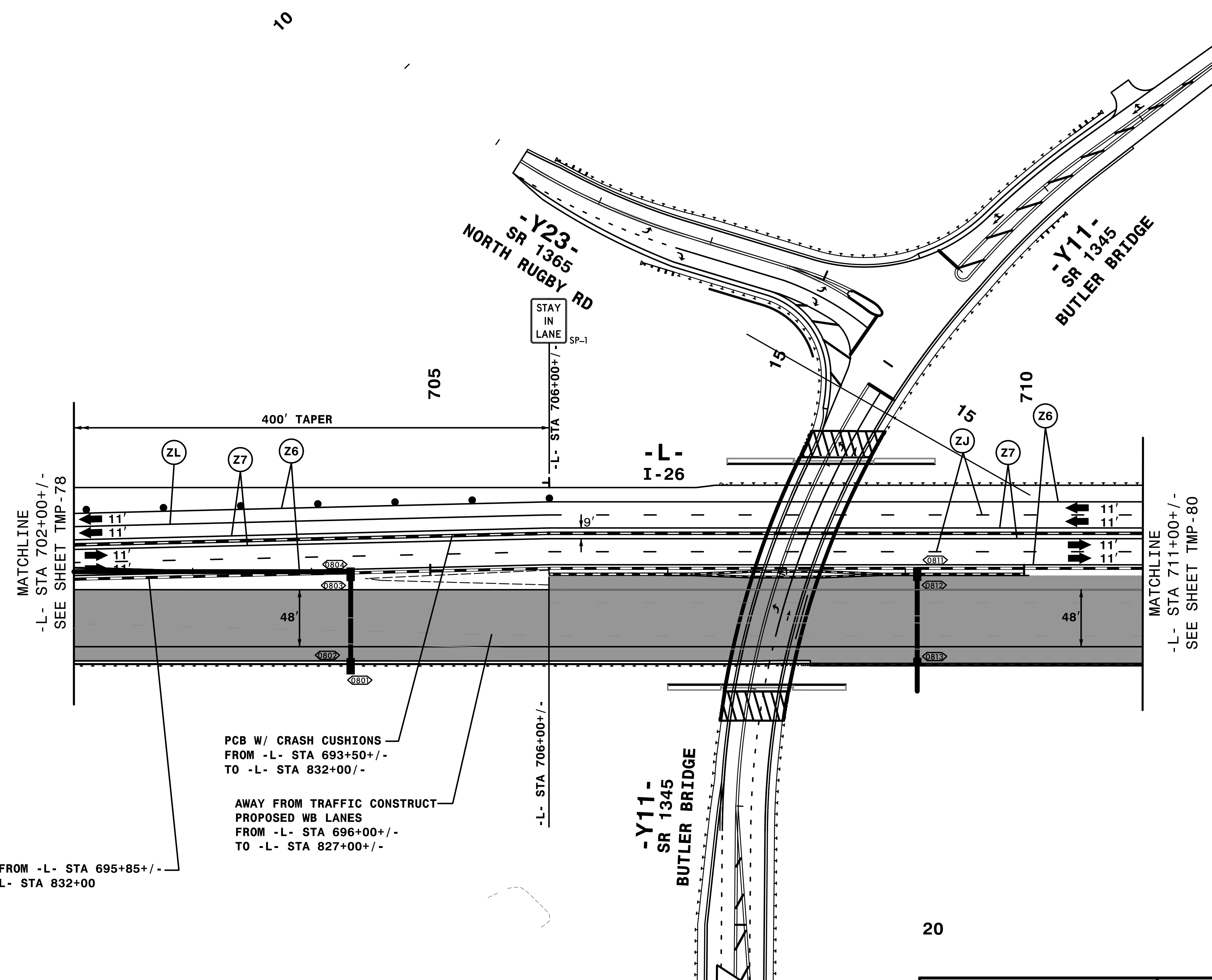

3:37:44 PM
I:\CP\4400C-1c-A2-P3.dwg
9/3/2019

HNTB
 HNTB NORTH CAROLINA, P.C.
 343 E. SIX FORKS ROAD, SUITE 200
 RALEIGH, NORTH CAROLINA 27609
 NC LICENSE NO: C-1554

APPROVED: *Rhonda B. Early*
 DATE: 9/3/2019

DocuSigned by:
 Rhonda B. Early
 F5MC4FSA08F48A

NORTH CAROLINA
 PROFESSIONAL
 SEAL
 023521
 ENGINEER
 RHONDA B. EARLY

**DOCUMENT NOT CONSIDERED FINAL
 UNLESS ALL SIGNATURES COMPLETED**

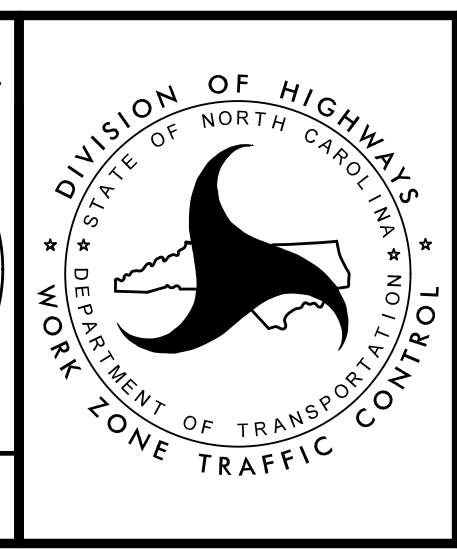

TRANSPORTATION
 MANAGEMENT PLAN

PHASE III
 DETAIL

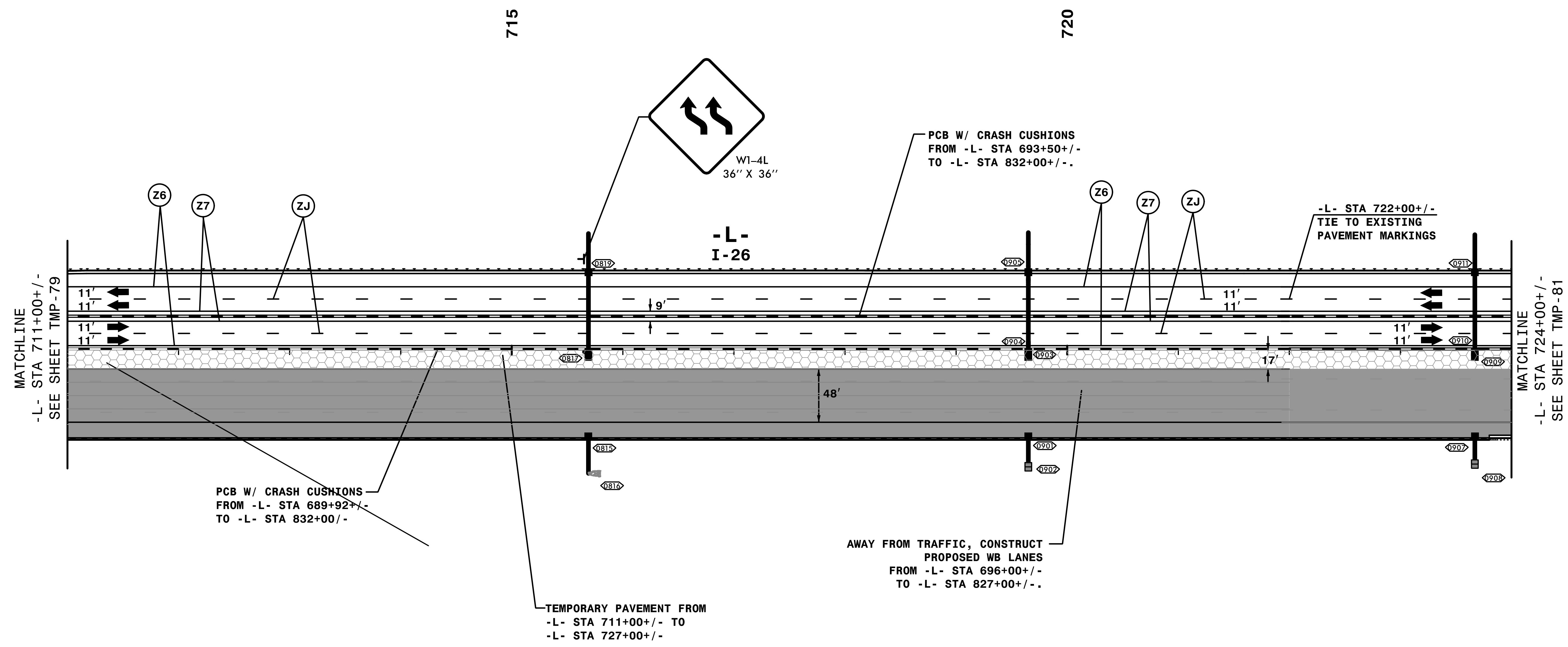

3:37:36 PM
 \\TCN\4400C-1c-A2_P3d2.dgn
 9/3/2019

HNTB
 HNTB NORTH CAROLINA, P.C.
 343 E. SIX FORKS ROAD, SUITE 200
 RALEIGH, NORTH CAROLINA 27609
 NC License No: C-1554

DocuSigned by:
Rhonda B. Early
 F5MC4FSA08F48A
 APPROVED: _____
 DATE: 9/3/2019

PROFESSIONAL ENGINEER
 NORTH CAROLINA
 SEAL
 023521
 RHONDA B. EARLY

**DOCUMENT NOT CONSIDERED FINAL
 UNLESS ALL SIGNATURES COMPLETED**

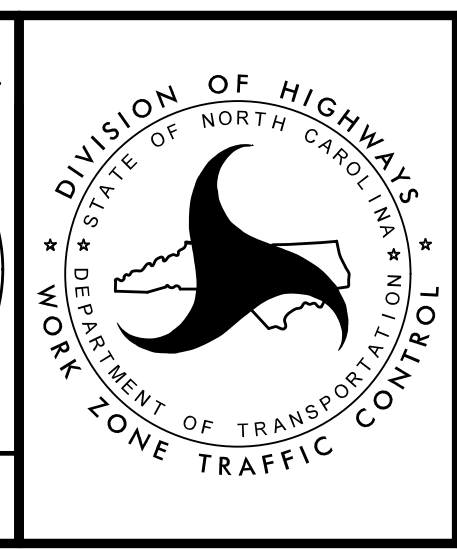

TRANSPORTATION
 MANAGEMENT PLAN

PHASE III
 DETAIL

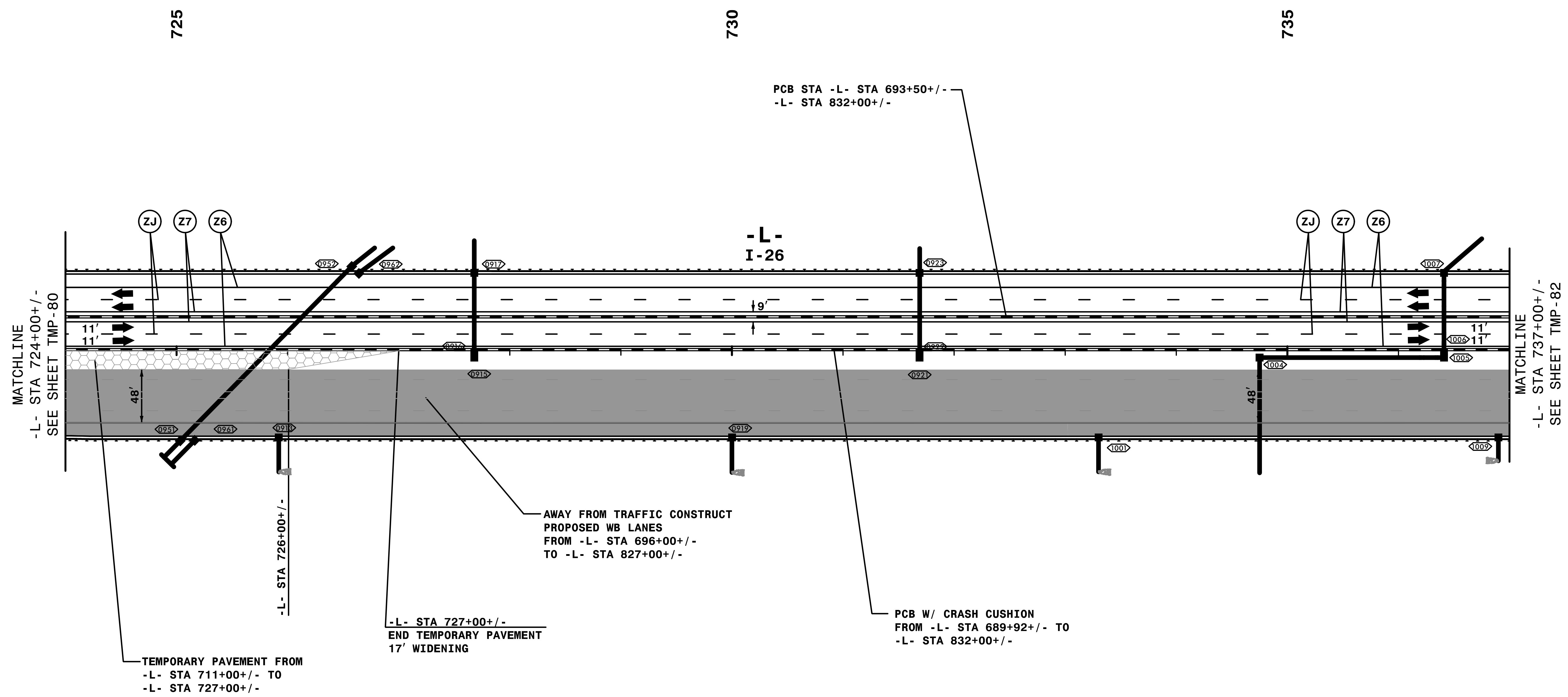
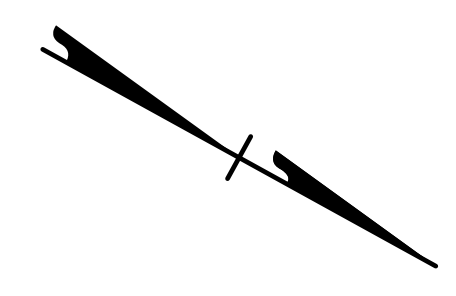

MATCHLINE
-L- STA 724+00+/-
SEE SHEET TMP-80

MATCHLINE
-L- STA 737+00+/-
SEE SHEET TMP-82

TEMPORARY PAVEMENT FROM
-L- STA 711+00+/- TO
-L- STA 727+00+/-

-L- STA 727+00+/-
END TEMPORARY PAVEMENT
17' WIDENING

AWAY FROM TRAFFIC CONSTRUCT
PROPOSED WB LANES
FROM -L- STA 696+00+/-
TO -L- STA 827+00+/-

PCB W/ CRASH CUSHION
FROM -L- STA 689+92+/- TO
-L- STA 832+00+/-

REMOVE CONFLICTING PAVEMENT MARKING.

3:38:01 PM
\\TCN\4400C-1c-A3_P3.dwg
9/3/2019

HNTB
HNTB NORTH CAROLINA, P.C.
343 E. Six Forks Road, Suite 200
Raleigh, North Carolina 27609
NC License No: C-1554

APPROVED: *Rhonda B. Early*
DATE: 9/3/2019

DocuSigned by:
Rhonda B. Early
F5MC4FSA08BF48A

NORTH CAROLINA
PROFESSIONAL
SEAL
023521
ENGINEER
RHONDA B. EARLY

**DOCUMENT NOT CONSIDERED FINAL
UNLESS ALL SIGNATURES COMPLETED**

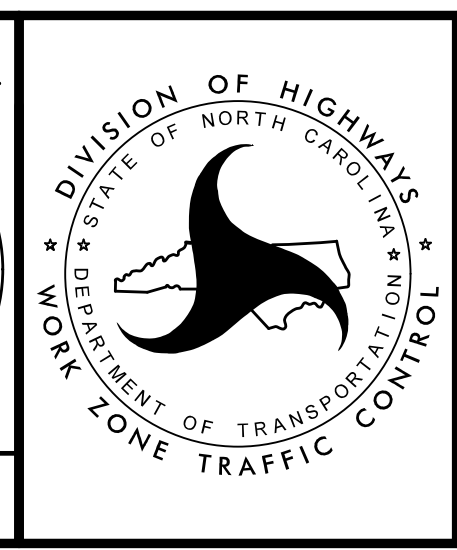

TRANSPORTATION
MANAGEMENT PLAN

PHASE III
DETAIL

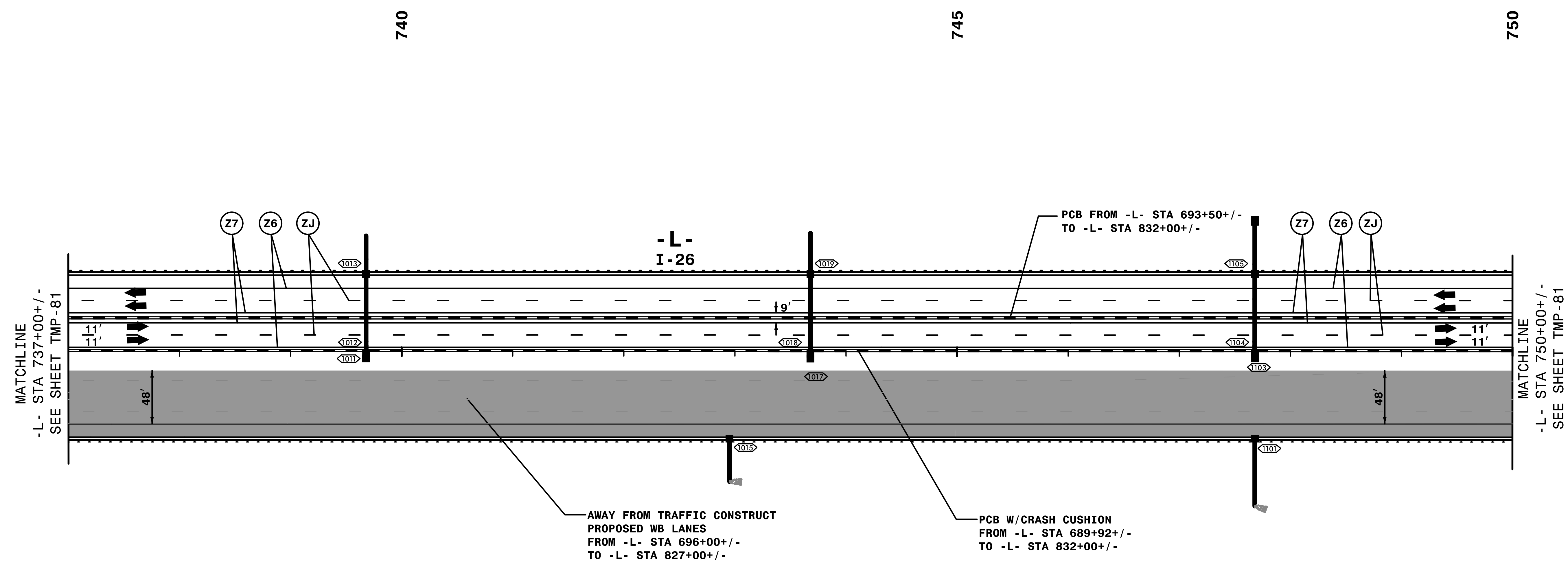

REMOVE CONFLICTING PAVEMENT MARKING.

3:38:17 PM
C:\TCP\4400C-TC-A3_P3d2.dgn
9/3/2019



APPROVED: *Rhonda B. Early*
DocuSigned by:
F5MC4FSA06BF48A...

DATE: 9/3/2019

PROFESSIONAL ENGINEER
 NORTH CAROLINA
 SEAL
 023521
 RHONDA B. EARLY

**DOCUMENT NOT CONSIDERED FINAL
UNLESS ALL SIGNATURES COMPLETED**



TRANSPORTATION
MANAGEMENT PLAN

**PHASE III
DETAIL**

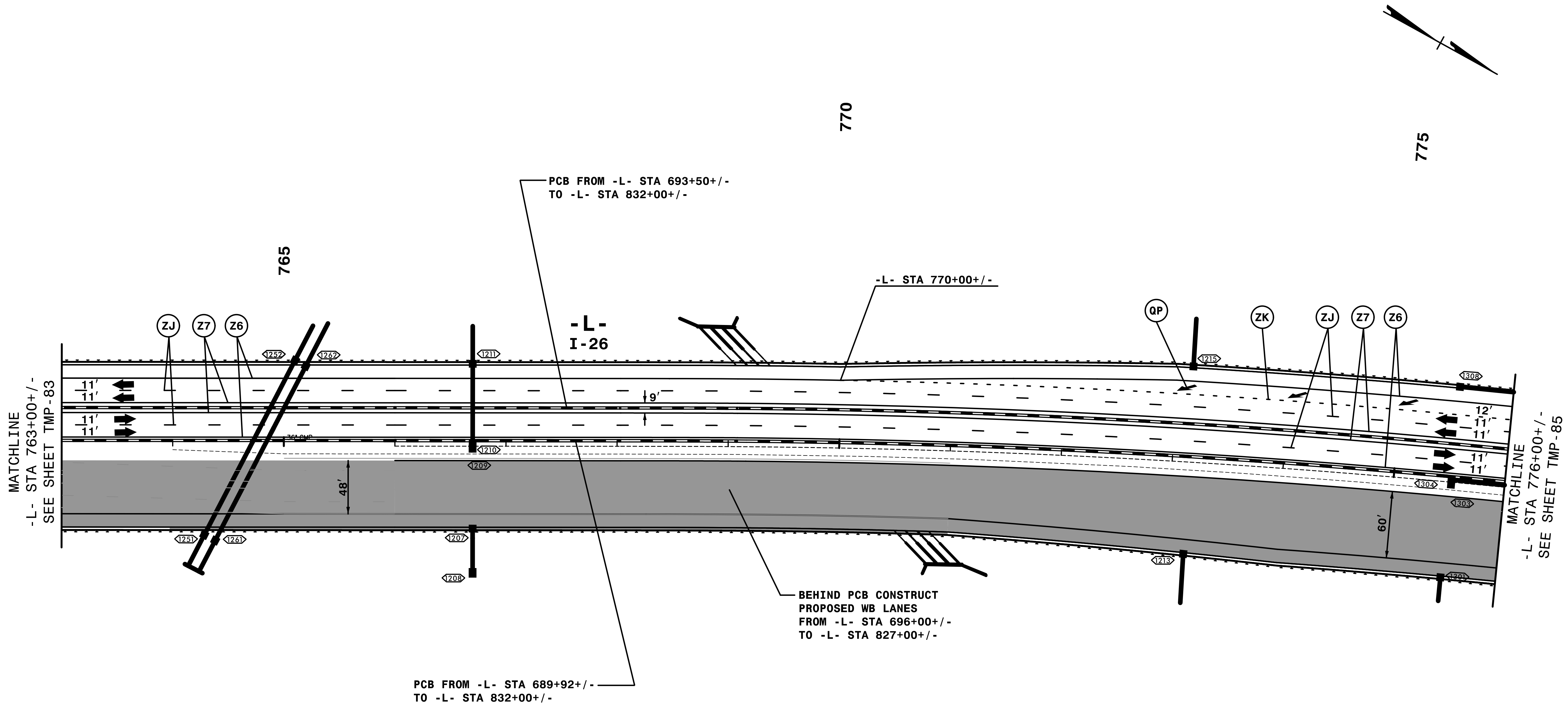

REMOVE CONFLICTING PAVEMENT MARKING.

3:38:50 PM
C:\CP\4400C-TC-A3_P3d4.dgn
9/3/2019

HNTB HNTB NORTH CAROLINA, P.C.
343 E. SIX FORKS ROAD, SUITE 200
RALEIGH, NORTH CAROLINA 27609
NC LICENSE NO: C-1554

DocuSigned by:
Rhonda B. Early
APPROVED: Rhonda B. Early
F34C4F5A26B8F48A...
DATE: 9/3/2019

NORTH CAROLINA
PROFESSIONAL
ENGINEERS
RHONDA B. EARLY
023521

**DOCUMENT NOT CONSIDERED FINAL
UNLESS ALL SIGNATURES COMPLETED**

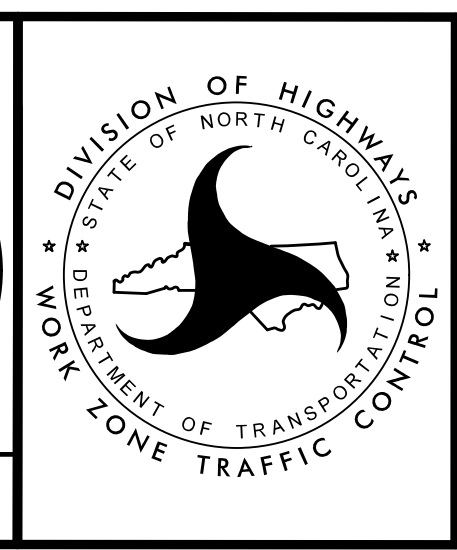

TRANSPORTATION
MANAGEMENT PLAN

PHASE III
DETAIL

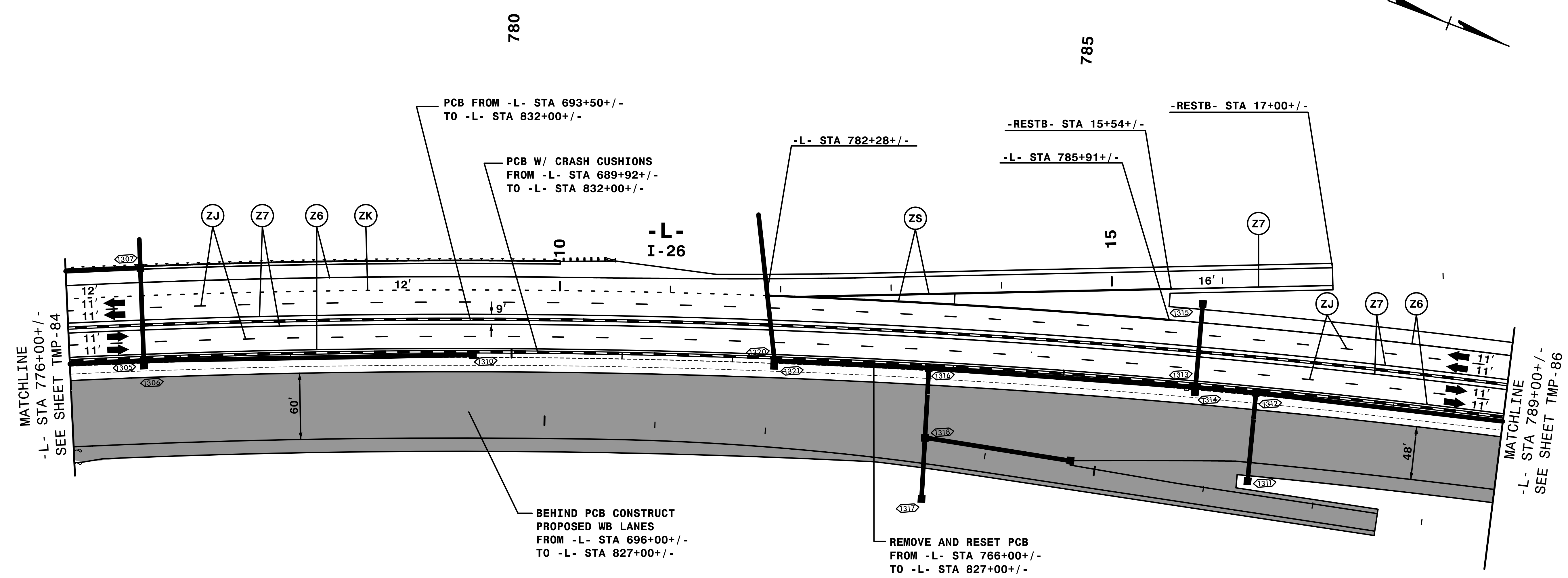

REMOVE CONFLICTING PAVEMENT MARKING.

3:39:04 PM
 \\TCN\4400C-1c_A4_P3.dgn
 9/3/2019

HNTB
 HNTB NORTH CAROLINA, P.C.
 343 E. Six Forks Road, Suite 200
 Raleigh, North Carolina 27609
 NC License No: C-1554

APPROVED: *Rhonda B. Early*
 DATE: 9/3/2019
 NORTH CAROLINA PROFESSIONAL ENGINEER
 SEAL 023521
 RHONDA B. EARLY
 DOCUMENT NOT CONSIDERED FINAL UNLESS ALL SIGNATURES COMPLETED

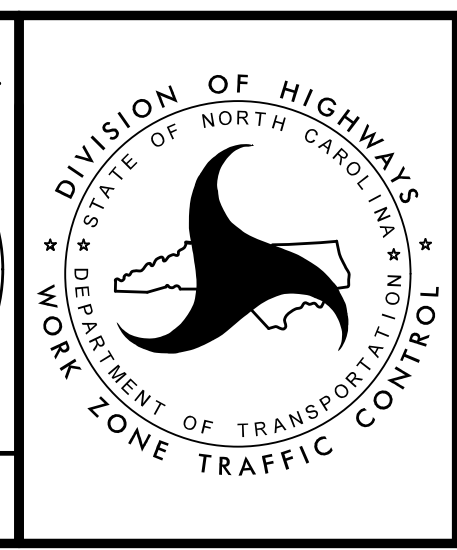

TRANSPORTATION MANAGEMENT PLAN
 PHASE III
 DETAIL

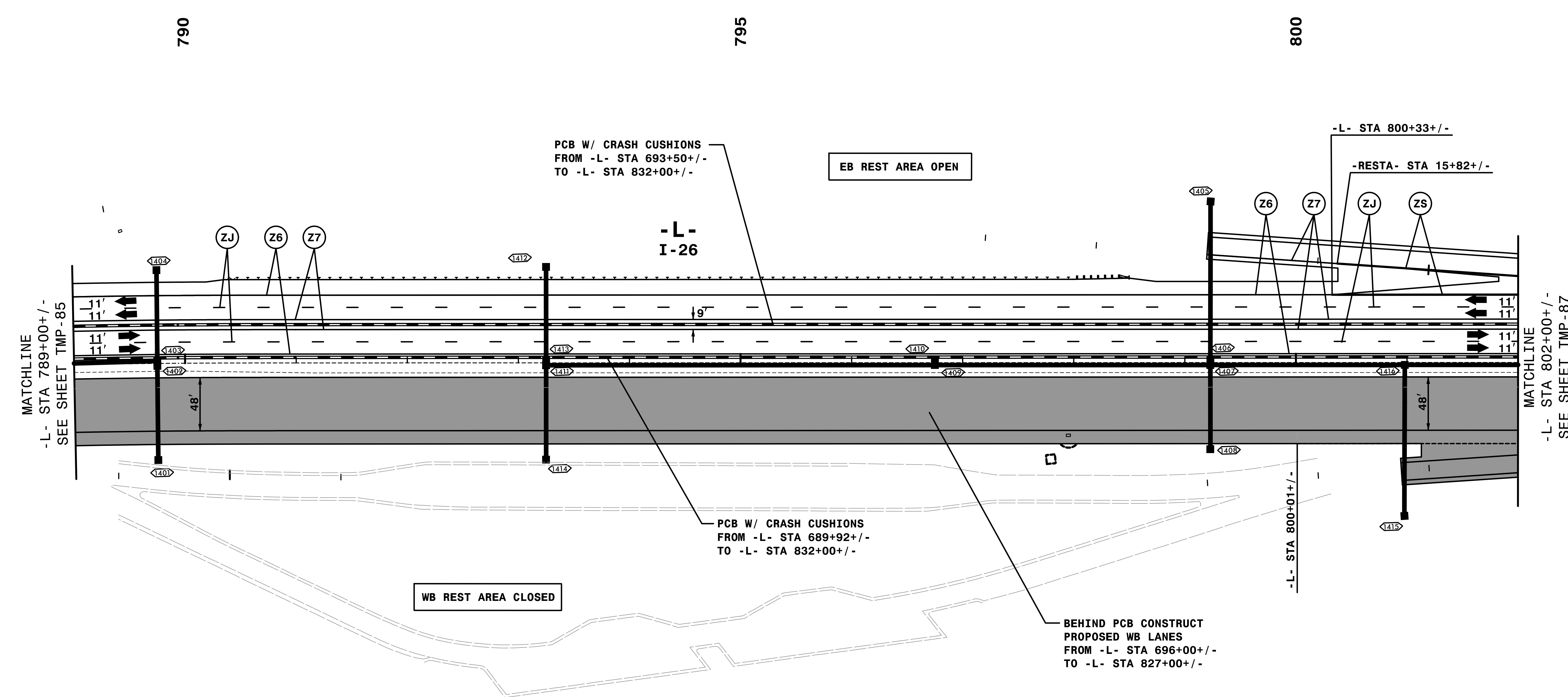
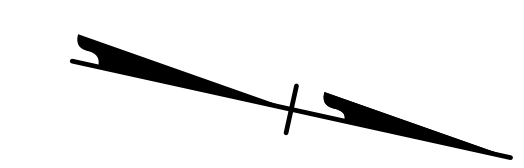

MATCHLINE
-L- STA 789+00+/-
SEE SHEET TMP - 85

MATCHLINE
-L- STA 802+00+/-
SEE SHEET TMP - 87

REMOVE CONFLICTING PAVEMENT MARKING.



APPROVED: *Rhonda B. Early*
FMCAFSAC08F48A
 DATE: 9/3/2019

PROFESSIONAL ENGINEER
 NORTH CAROLINA
 SEAL
 023521
 RHONDA B. EARLY

**DOCUMENT NOT CONSIDERED FINAL
 UNLESS ALL SIGNATURES COMPLETED**

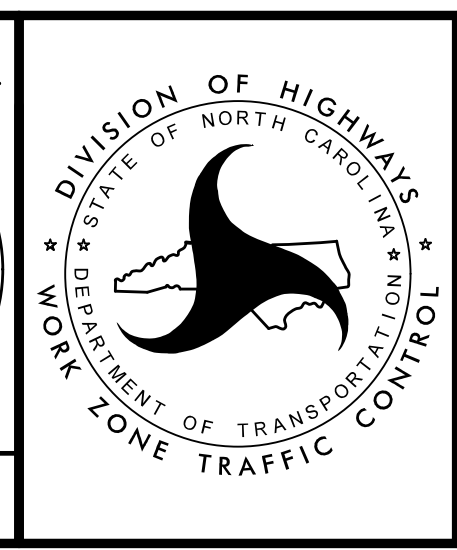

TRANSPORTATION
MANAGEMENT PLAN

PHASE III
DETAIL

3:39:18 PM
 \\TC\N\4400C-TC-A4_P3d2.dgn
 9/3/2019

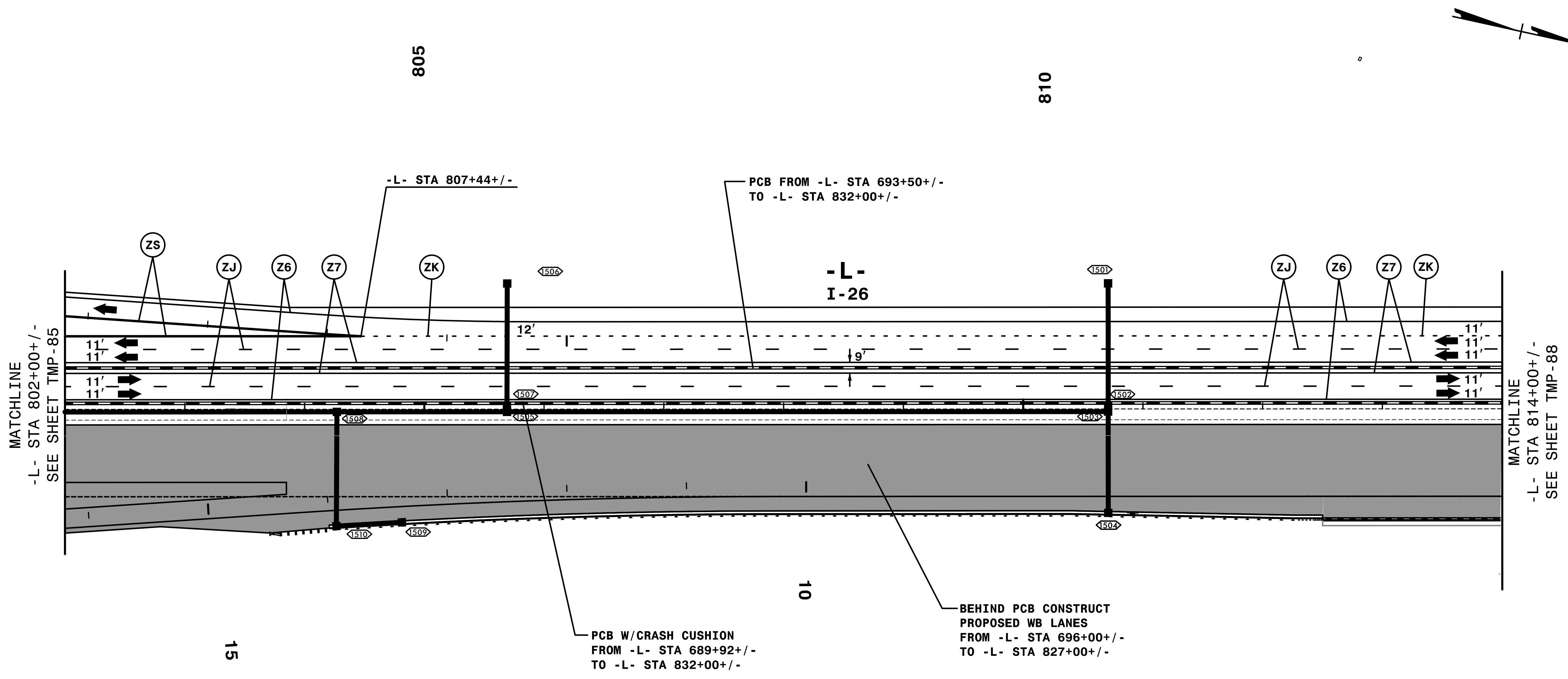

REMOVE CONFLICTING PAVEMENT MARKING.

3:39:35 PM
\\TCN\4400C-TC-A4_P3d3.dgn
9/3/2019

HNTB
 HNTB NORTH CAROLINA, P.C.
 343 E. Six Forks Road, Suite 200
 Raleigh, North Carolina 27609
 NC License No: C-1554

DocuSigned by:
APPROVED: Rhonda B. Early
 F5MC4FSA08BF48A...
DATE: 9/3/2019

SEAL
 NORTH CAROLINA
 PROFESSIONAL
 ENGINEER
 RHONDA B. EARLY
 023521

**DOCUMENT NOT CONSIDERED FINAL
 UNLESS ALL SIGNATURES COMPLETED**

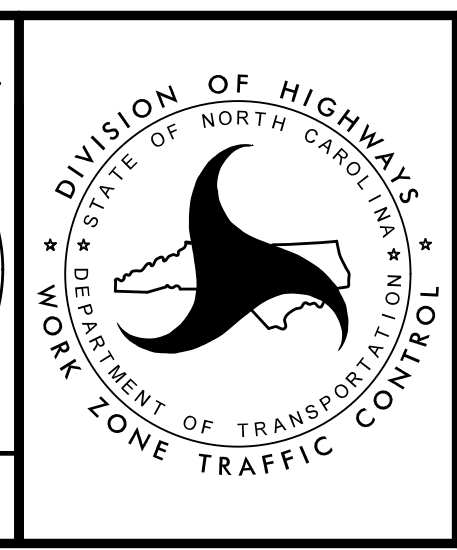

TRANSPORTATION
 MANAGEMENT PLAN

PHASE III
 DETAIL

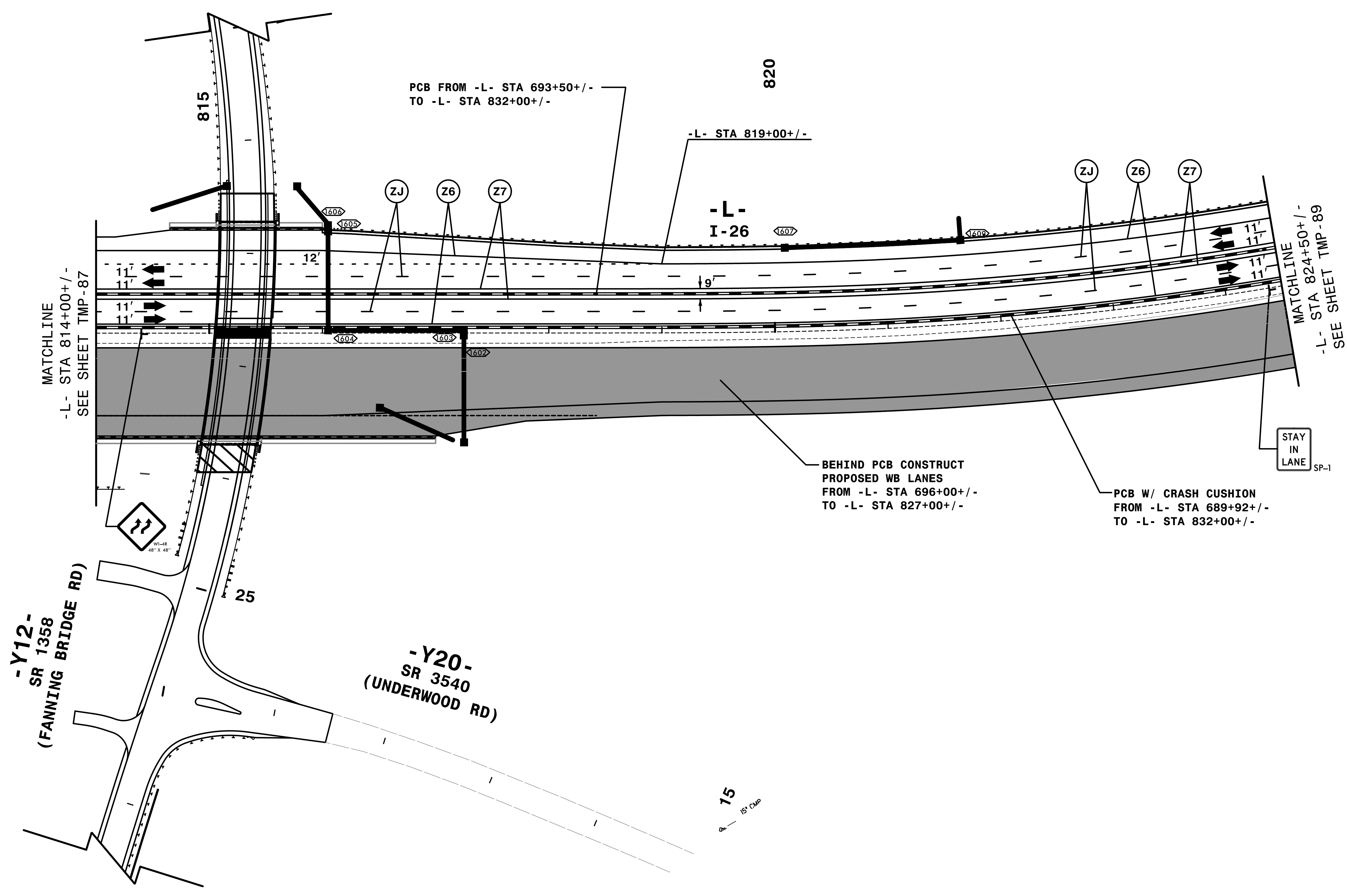

-Y12-
SR 1358
(FANNING BRIDGE RD)

-Y20-
SR 3540
(UNDERWOOD RD)

REMOVE CONFLICTING PAVEMENT MARKING.

SEE PMP FOR FINAL PAVEMENT MARKING ON -Y12-.

3:39:50 PM
\\TCN\4400C-TC-A4-P3d4.dgn
9/3/2019

HNTB
HNTB NORTH CAROLINA, P.C.
343 E. SIX FORKS ROAD, SUITE 200
RALEIGH, NORTH CAROLINA 27609
NC LICENSE NO: C-1554

APPROVED: *Rhonda B. Early*
DATE: 9/3/2019

SEAL
NORTH CAROLINA
PROFESSIONAL
ENGINEER
RHONDA B. EARLY
023521

DOCUMENT NOT CONSIDERED FINAL
UNLESS ALL SIGNATURES COMPLETED

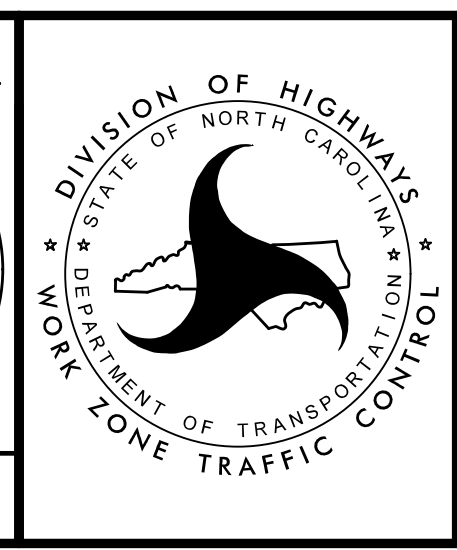

TRANSPORTATION
MANAGEMENT PLAN

PHASE III
DETAIL

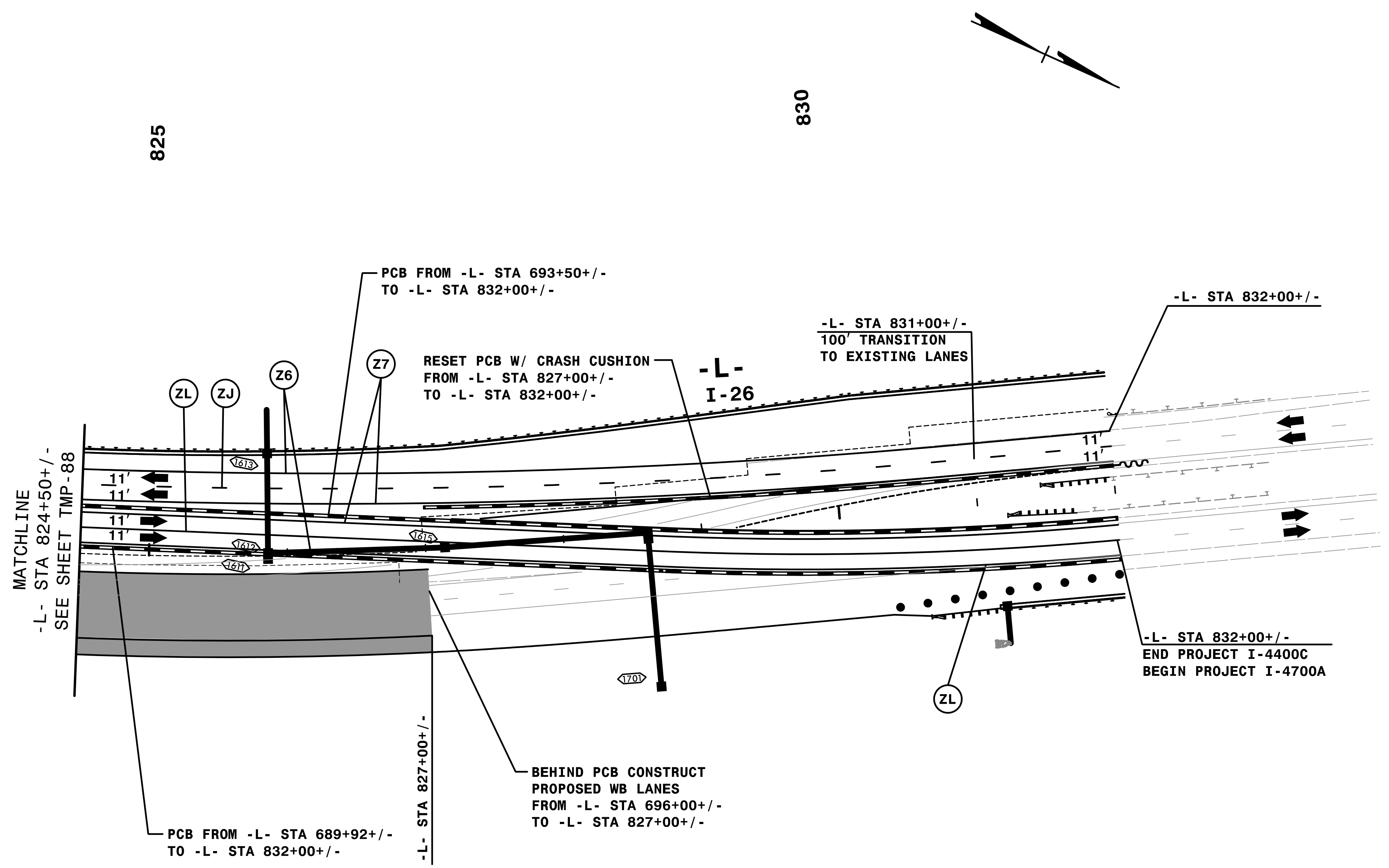

REMOVE CONFLICTING PAVEMENT MARKING.

3:40:06 PM
\\TCN\4400C-1c_A4_P3d5.dgn
9/3/2019

HNTB
 HNTB NORTH CAROLINA, P.C.
 343 E. Six Forks Road, Suite 200
 Raleigh, North Carolina 27609
 NC License No: C-1554

APPROVED: *Rhonda B. Early*
 DATE: 9/3/2019

DocuSigned by:
 Rhonda B. Early
 F5MC4FSA08BF48A...

PROFESSIONAL ENGINEER SEAL
 NORTH CAROLINA
 023521
 RHONDA B. EARLY

**DOCUMENT NOT CONSIDERED FINAL
 UNLESS ALL SIGNATURES COMPLETED**



TRANSPORTATION
 MANAGEMENT PLAN

PHASE III
 DETAIL

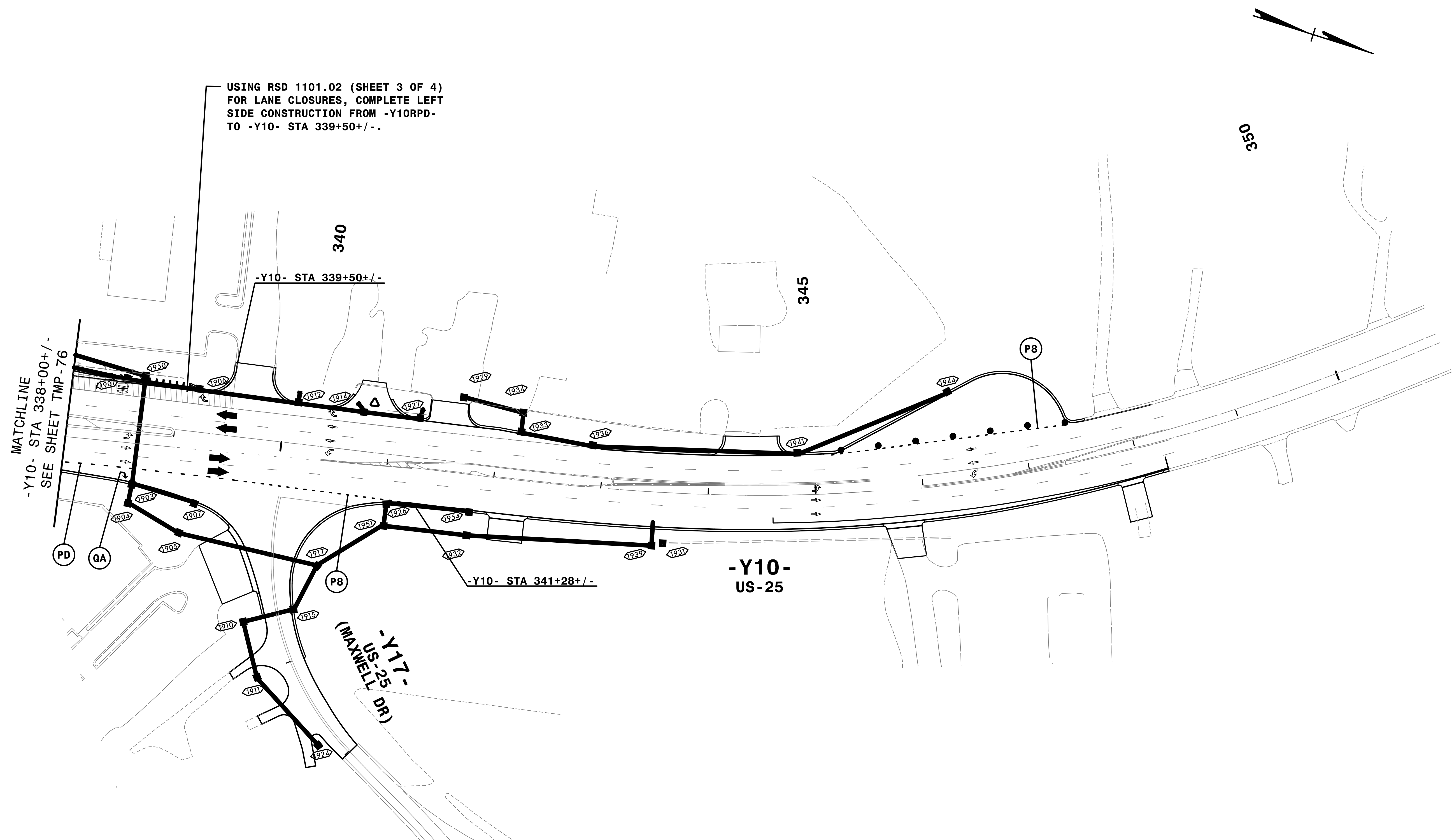

USING RSD 1101.02 (SHEET 3 OF 4)
FOR LANE CLOSURES, COMPLETE LEFT
SIDE CONSTRUCTION FROM -Y10RPD-
TO -Y10- STA 339+50+/-.

MATCHLINE
-Y10- STA 338+00+/-
SEE SHEET TMP-76

REMOVE CONFLICTING PAVEMENT MARKING.

10

3:40:25 PM
I:\CP\4400C-TC-ALP3d46.dgn
9/3/2019

HNTB
HNTB NORTH CAROLINA, P.C.
343 E. Six Forks Road, Suite 200
Raleigh, North Carolina 27609
NC License No: C-1554

DocuSigned by:
Rhonda B. Early
F5MC4FSA08BF48A...

APPROVED: _____
DATE: 9/3/2019

SEAL
NORTH CAROLINA
PROFESSIONAL
ENGINEERS
RHONDA B. EARLY
023521

**DOCUMENT NOT CONSIDERED FINAL
UNLESS ALL SIGNATURES COMPLETED**

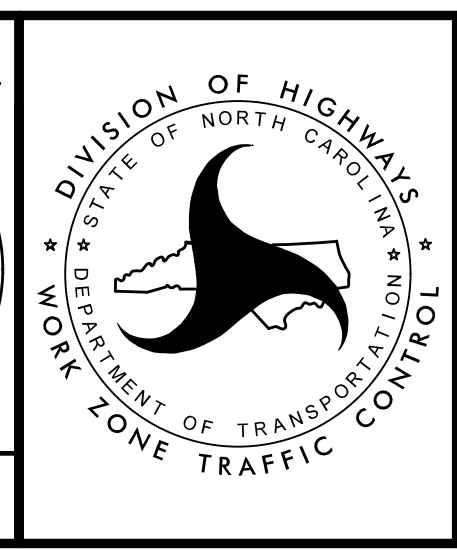

TRANSPORTATION
MANAGEMENT PLAN

PHASE III
DETAIL

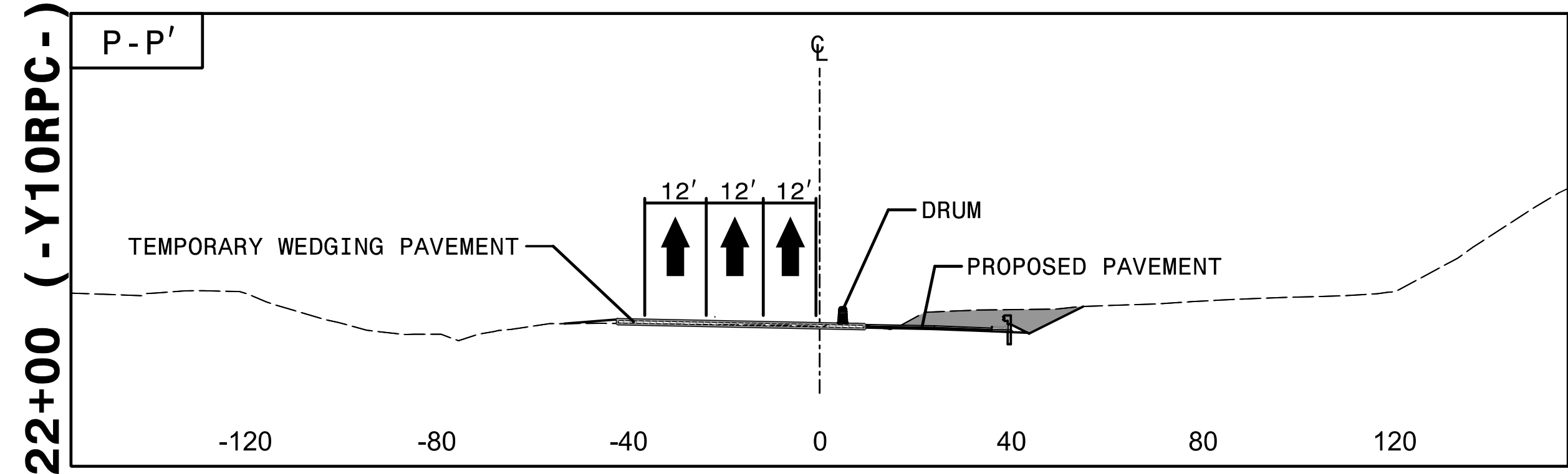
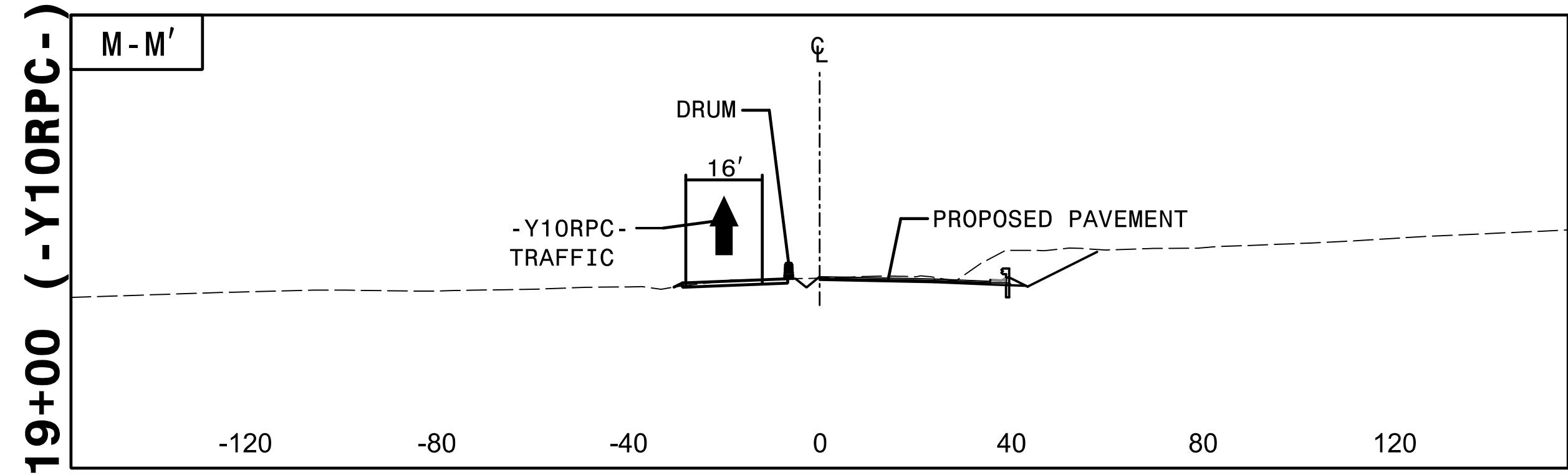
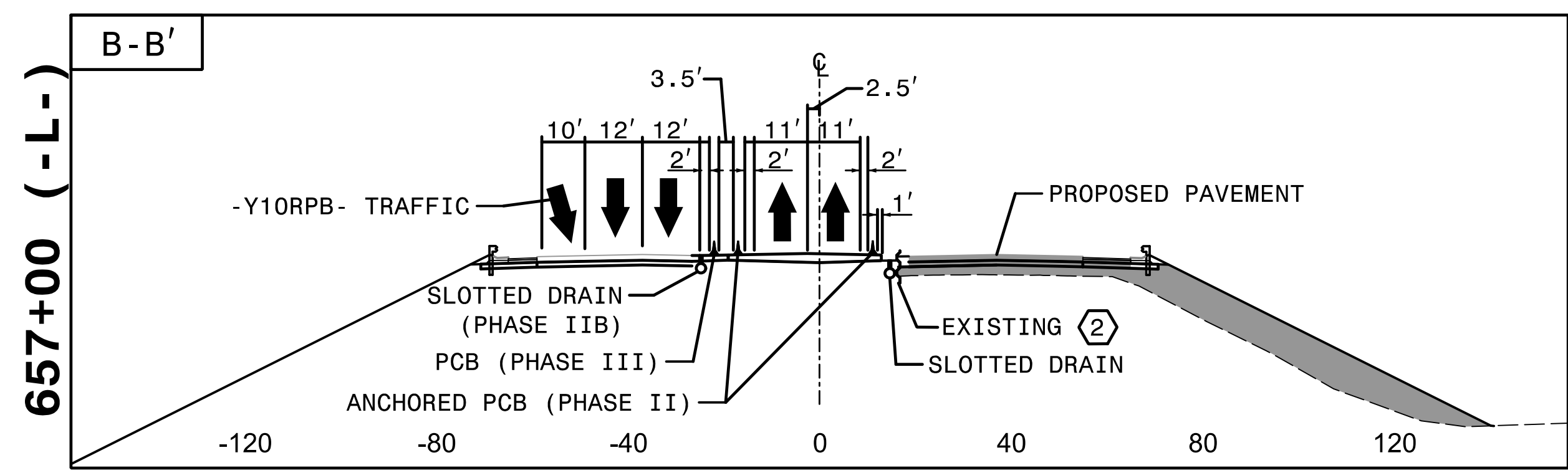

3:41:51 PM
N:\TCN\4400C_fc_P3 CUTS.dgn
9/3/2019

HNTB HNTB NORTH CAROLINA, P.C.
343 E. Six Forks Road, Suite 200
Raleigh, North Carolina 27609
NC License No: C-1554

APPROVED: *Rhonda B. Early*
DocuSigned by:
Rhonda B. Early
F3ACAF5ACDBF48A.
 DATE: 9/3/2019

**DOCUMENT NOT CONSIDERED FINAL
UNLESS ALL SIGNATURES COMPLETED**

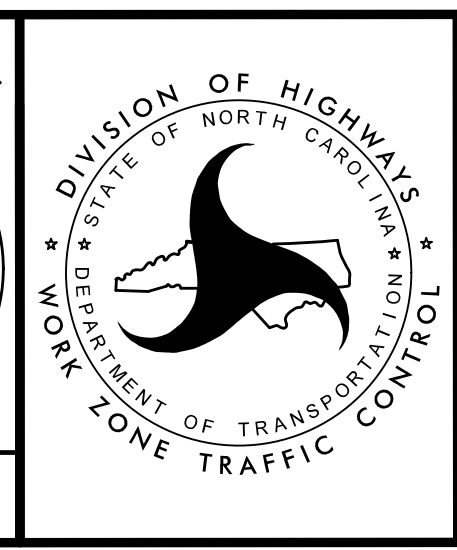

TRANSPORTATION
MANAGEMENT PLAN

**PHASE IIIA
CUT SECTIONS**

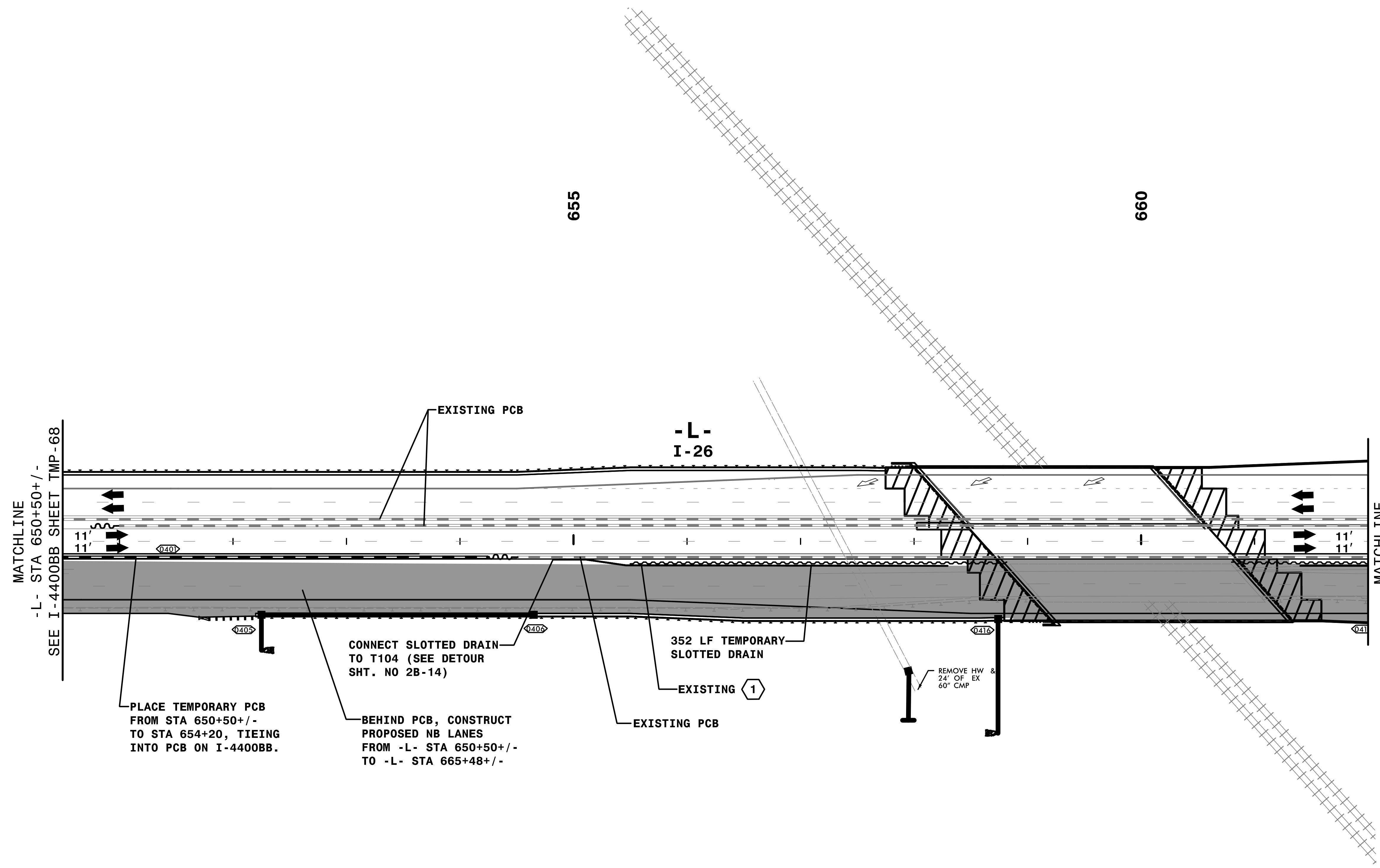
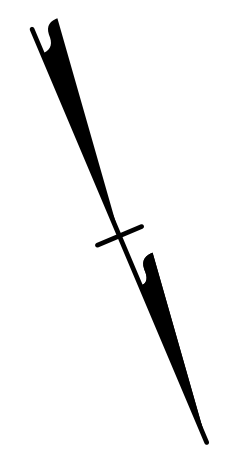

MATCHLINE
-L- STA 650+50+/-
SEE I-4400BB SHEET TMP-68

MATCHLINE
-L- STA 662+00+/-
SEE SHEET TMP-94

PLACE TEMPORARY PCB
FROM STA 650+50+/-
TO STA 654+20, TIEING
INTO PCB ON I-4400BB.

CONNECT SLOTTED DRAIN
TO T104 (SEE DETOUR
SHT. NO 2B-14)

BEHIND PCB, CONSTRUCT
PROPOSED NB LANES
FROM -L- STA 650+50+/-
TO -L- STA 665+48+/-

352 LF TEMPORARY
SLOTTED DRAIN

REMOVE HW &
24' OF EX
60' CMP

-L-
I-26

655

660

EXISTING PCB

EXISTING 1

EXISTING PCB

3:42:21PM
\\TCN\4400C-TC-ALP3adl.dgn
9/3/2019

HNTB
HNTB NORTH CAROLINA, P.C.
343 E. Six Forks Road, Suite 200
Raleigh, North Carolina 27609
NC License No: C-1554

DocuSigned by:
APPROVED: *Rhonda B. Early*
DATE: 9/3/2019

SEAL
NORTH CAROLINA
PROFESSIONAL
ENGINEER
RHONDA B. EARLY
023521

**DOCUMENT NOT CONSIDERED FINAL
UNLESS ALL SIGNATURES COMPLETED**

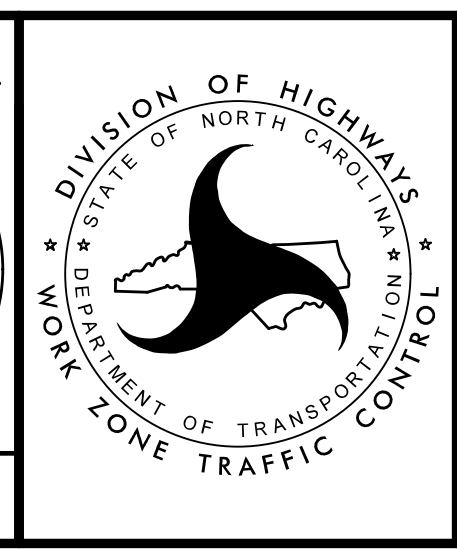

TRANSPORTATION
MANAGEMENT PLAN

PHASE IIIA
DETAIL

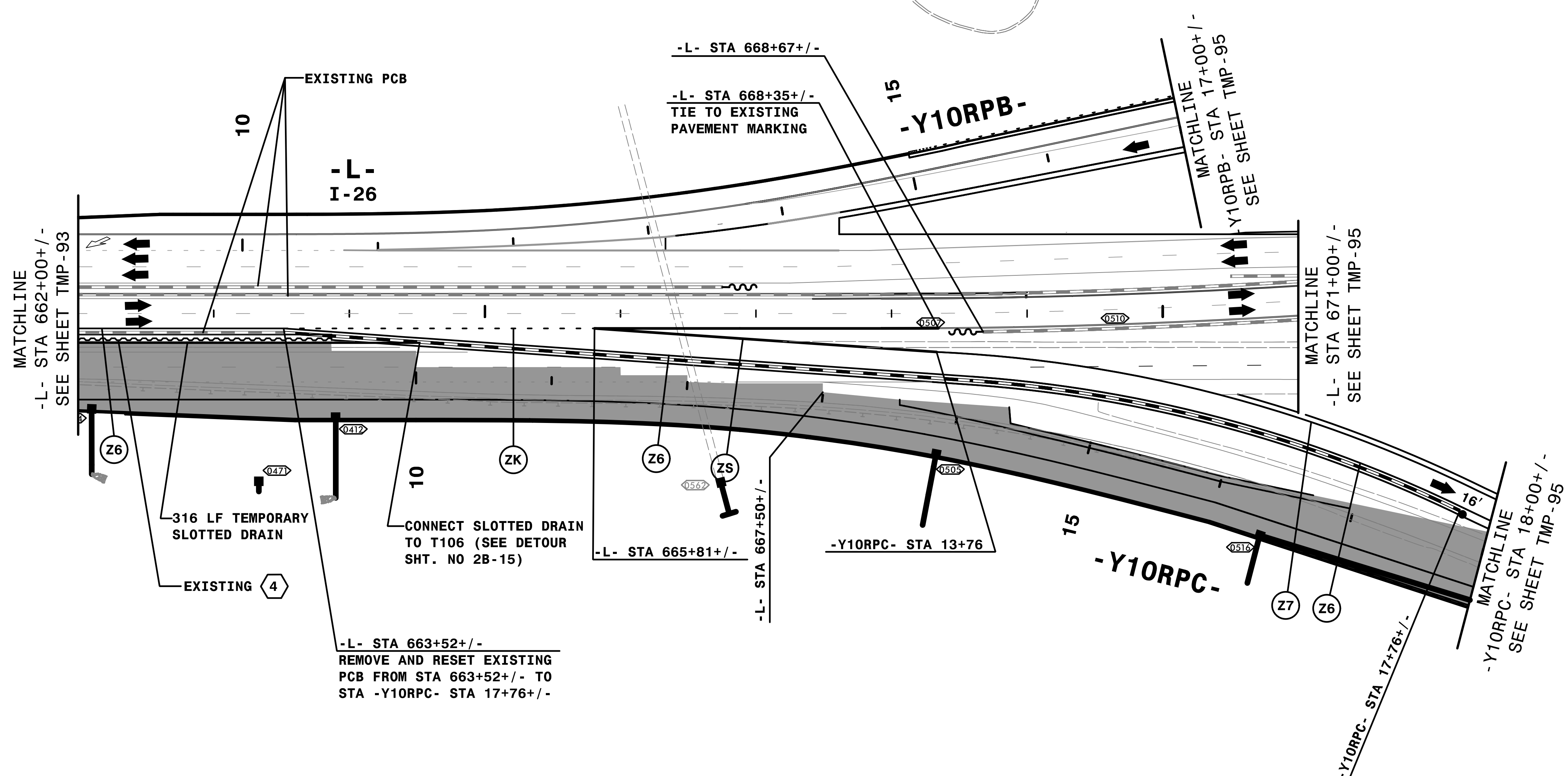
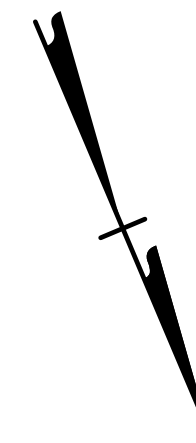

REMOVE CONFLICTING PAVEMENT MARKING.

3:42:30 PM
 I:\CPN\4400C-1c_ALP3ad2.dgn
 9/3/2019

HNTB
 HNTB NORTH CAROLINA, P.C.
 343 E. Six Forks Road, Suite 200
 Raleigh, North Carolina 27609
 NC License No: C-1554

APPROVED: *Rhonda B. Early*
 DATE: 9/3/2019

DocuSigned by:
 Rhonda B. Early
 F5MC4FSA08BF48A

NORTH CAROLINA
 PROFESSIONAL
 SEAL
 023521
 ENGINEER
 RHONDA B. EARLY

**DOCUMENT NOT CONSIDERED FINAL
 UNLESS ALL SIGNATURES COMPLETED**

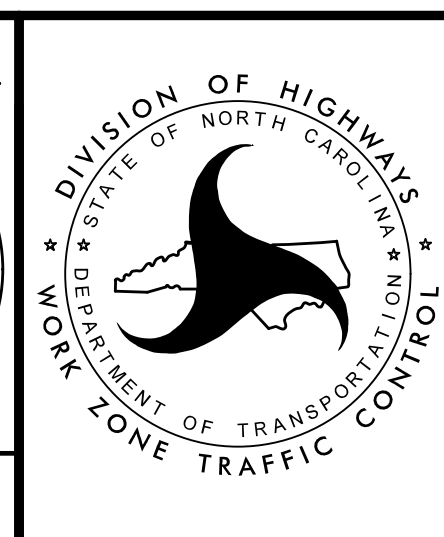

TRANSPORTATION
 MANAGEMENT PLAN

PHASE IIIA
 DETAIL

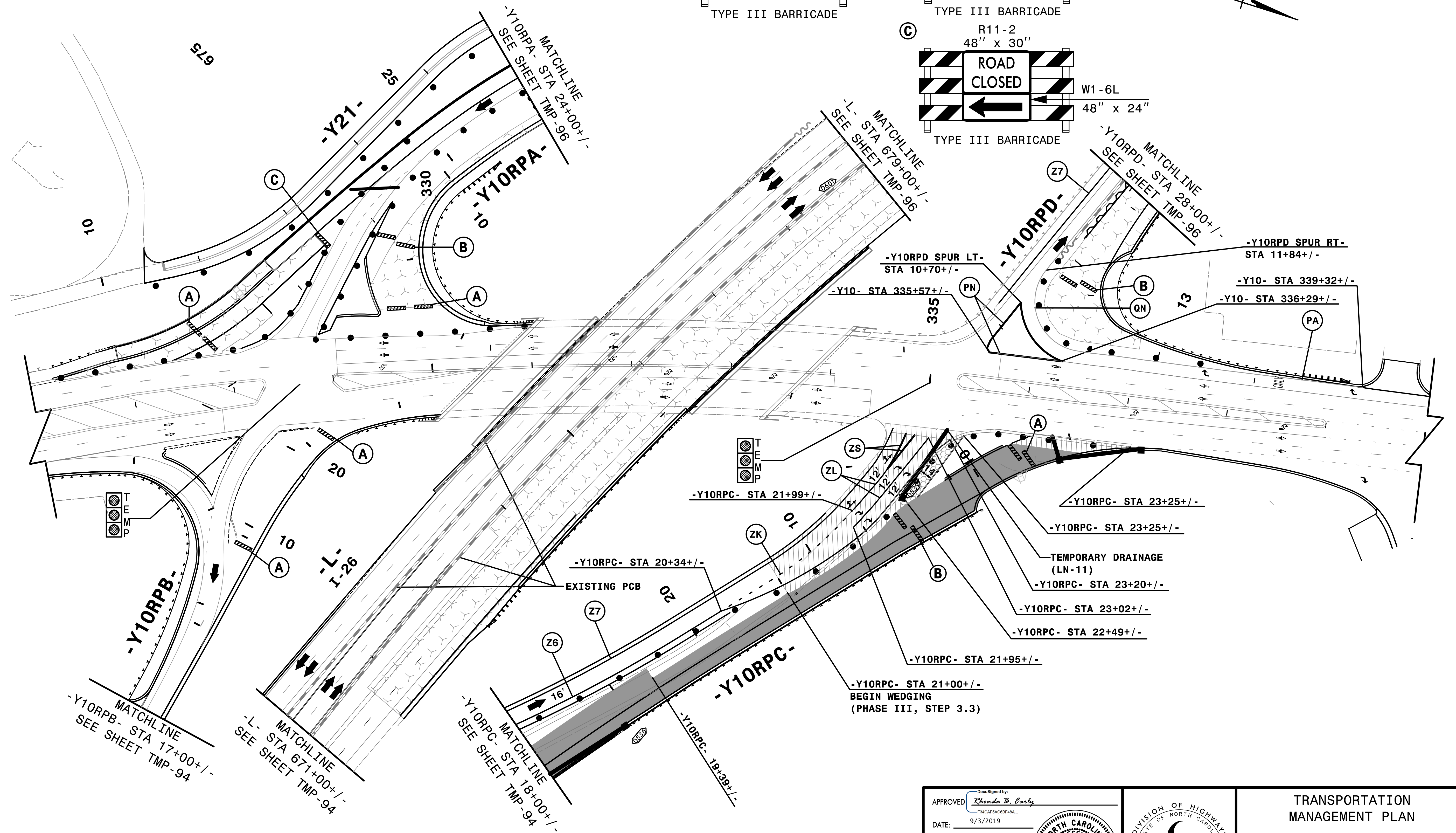
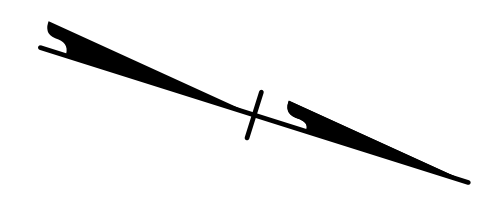
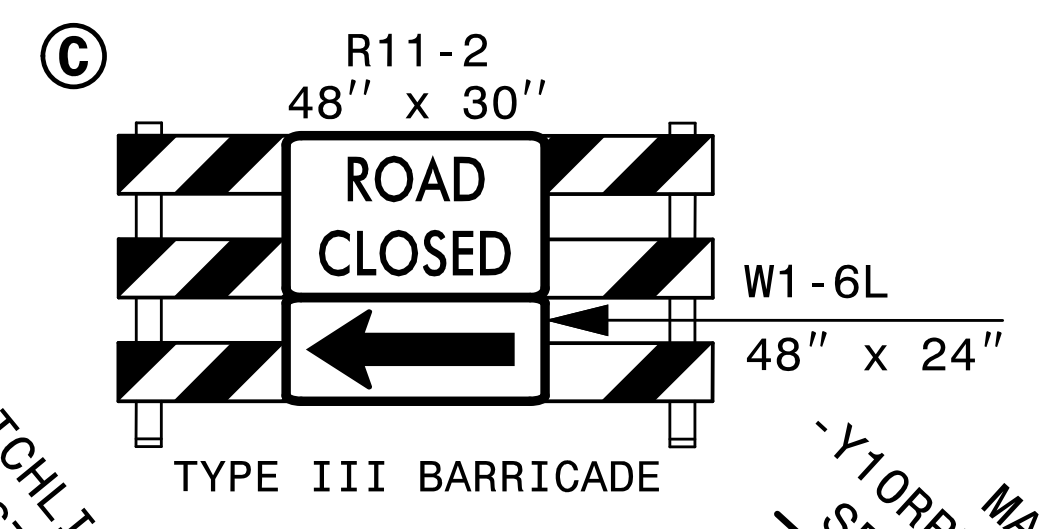
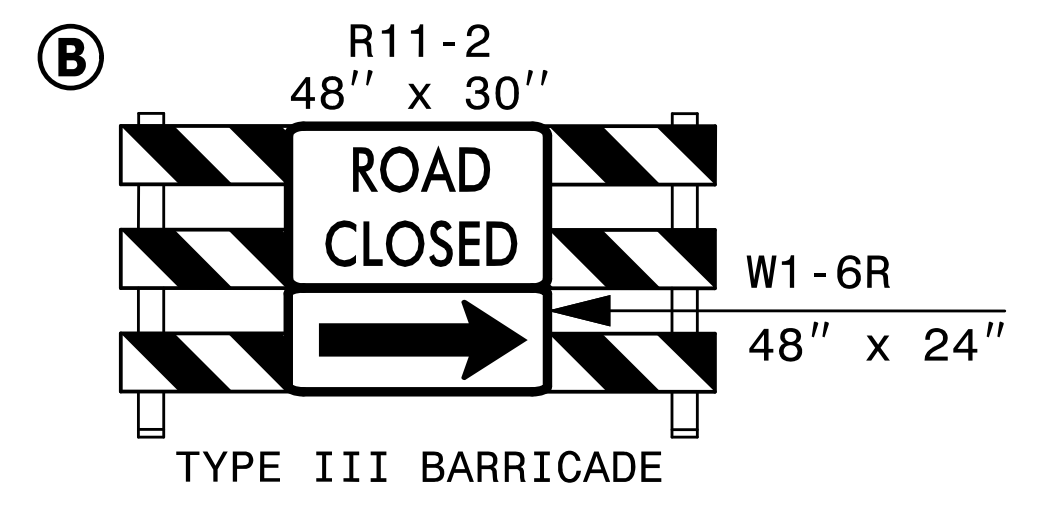
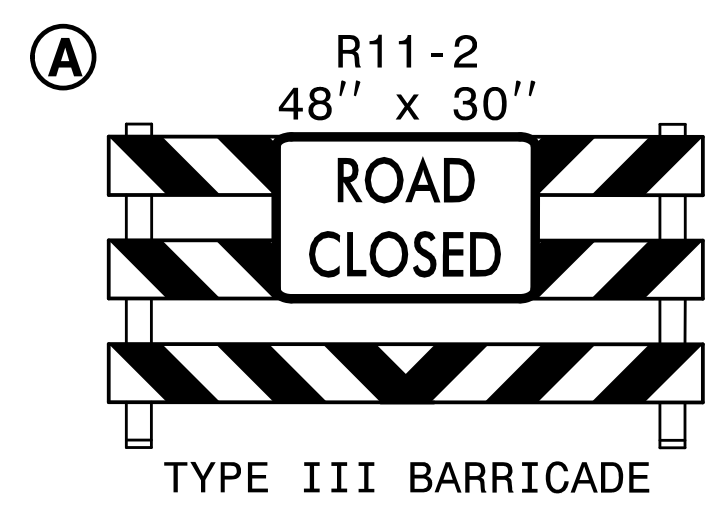

REMOVE CONFLICTING PAVEMENT MARKING.

3:43:00 PM
 TCPN\4400C-TC-ALP3ad3.dgn
 9/3/2019

HNTB
 HNTB NORTH CAROLINA, P.C.
 343 E. Six Forks Road, Suite 200
 Raleigh, North Carolina 27609
 NC License No: C-1554

DocuSigned by:
 APPROVED: *Rhonda B. Early*
 DATE: 9/3/2019

**DOCUMENT NOT CONSIDERED FINAL
 UNLESS ALL SIGNATURES COMPLETED**



TRANSPORTATION
 MANAGEMENT PLAN

PHASE IIIA
 DETAIL

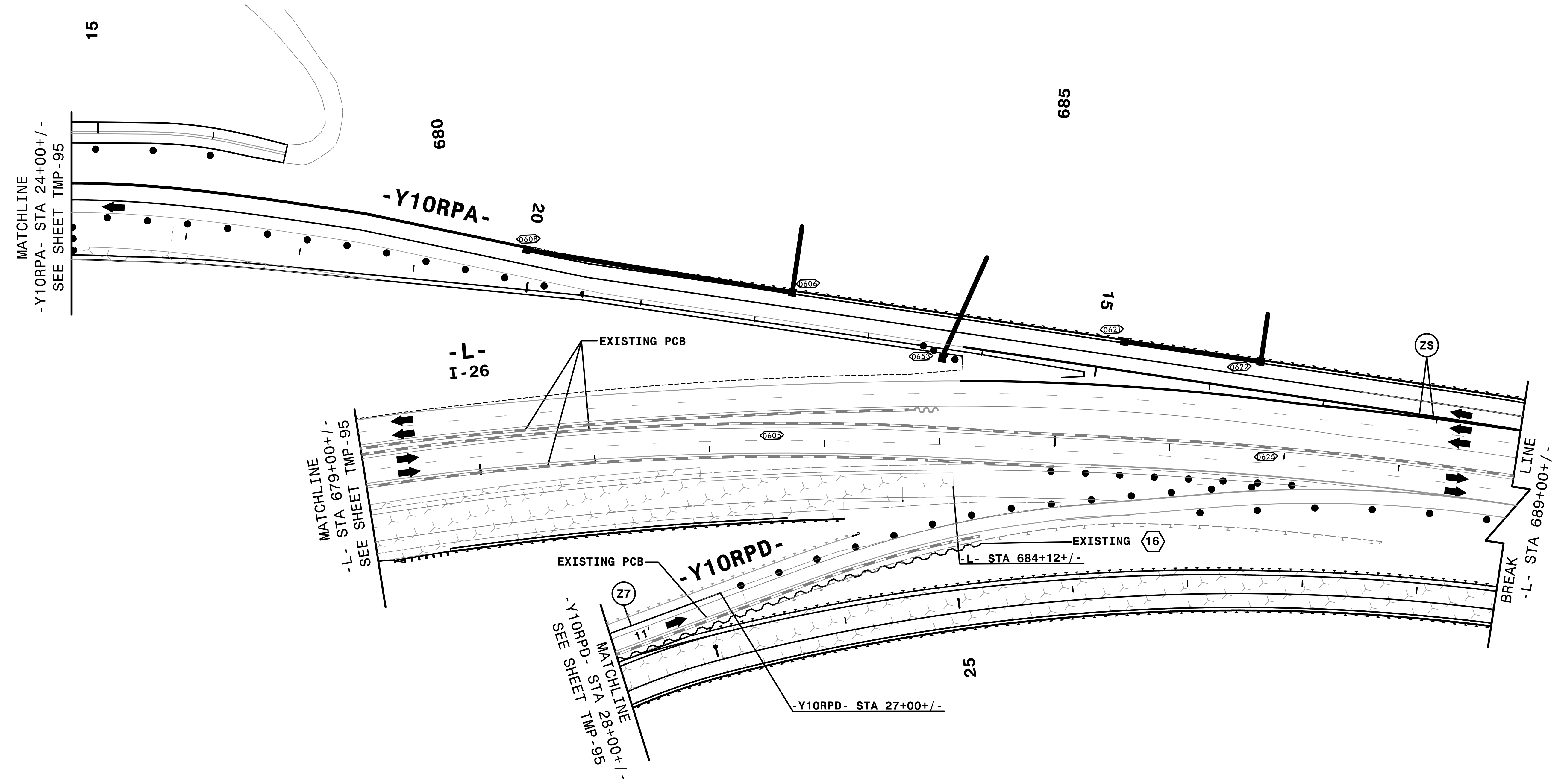
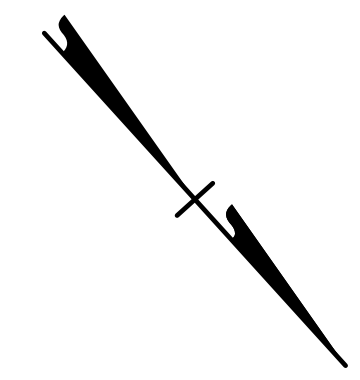

3:43:24 PM
 \\TCN\4400C-TC_ALP3ad4.dgn
 9/3/2019

HNTB HNTB NORTH CAROLINA, P.C.
 343 E. Six Forks Road, Suite 200
 Raleigh, North Carolina 27609
 NC License No: C-1554

APPROVED: *Rhonda B. Early*
 DATE: 9/3/2019

DocuSigned by:
 Rhonda B. Early
 F5MC4FSA08F48A

NORTH CAROLINA
 PROFESSIONAL
 SEAL
 023521
RHONDA B. EARLY
 ENGINEER

**DOCUMENT NOT CONSIDERED FINAL
 UNLESS ALL SIGNATURES COMPLETED**

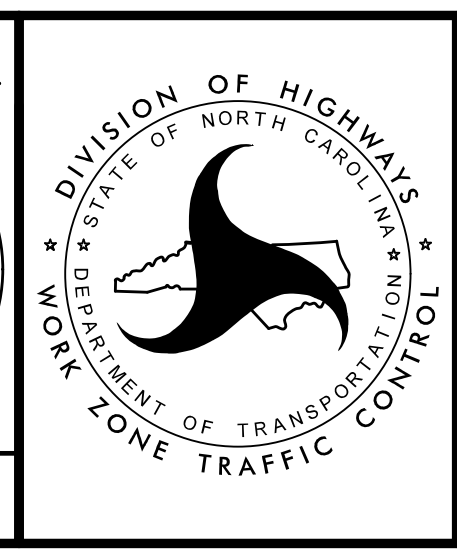

TRANSPORTATION
 MANAGEMENT PLAN

PHASE IIIA
 DETAIL

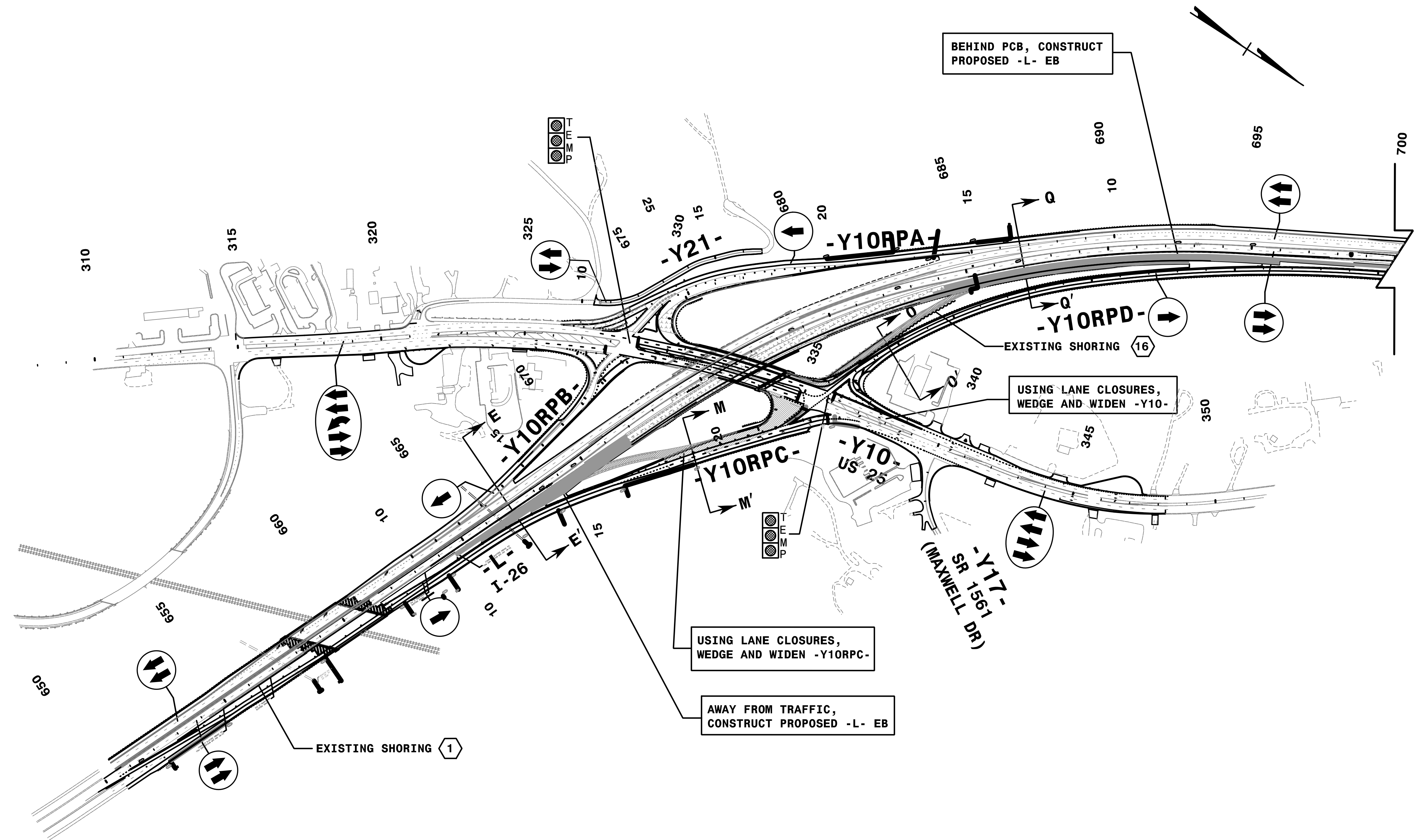

REFER TO SHEET TMP-98 FOR CUT SECTION(S).

3:44:02 PM
\\TCN\4400C-1c_PHASE_3b_0V.dgn
9/3/2019

HNTB
 HNTB NORTH CAROLINA, P.C.
 343 E. Six Forks Road, Suite 200
 Raleigh, North Carolina 27609
 NC License No: C-1554

APPROVED: *Rhonda B. Early*
 DATE: 9/3/2019
 NORTH CAROLINA PROFESSIONAL ENGINEER SEAL 023521
 RHONDA B. EARLY

**DOCUMENT NOT CONSIDERED FINAL
 UNLESS ALL SIGNATURES COMPLETED**



TRANSPORTATION
 MANAGEMENT PLAN

PHASE IIIB
 OVERVIEW

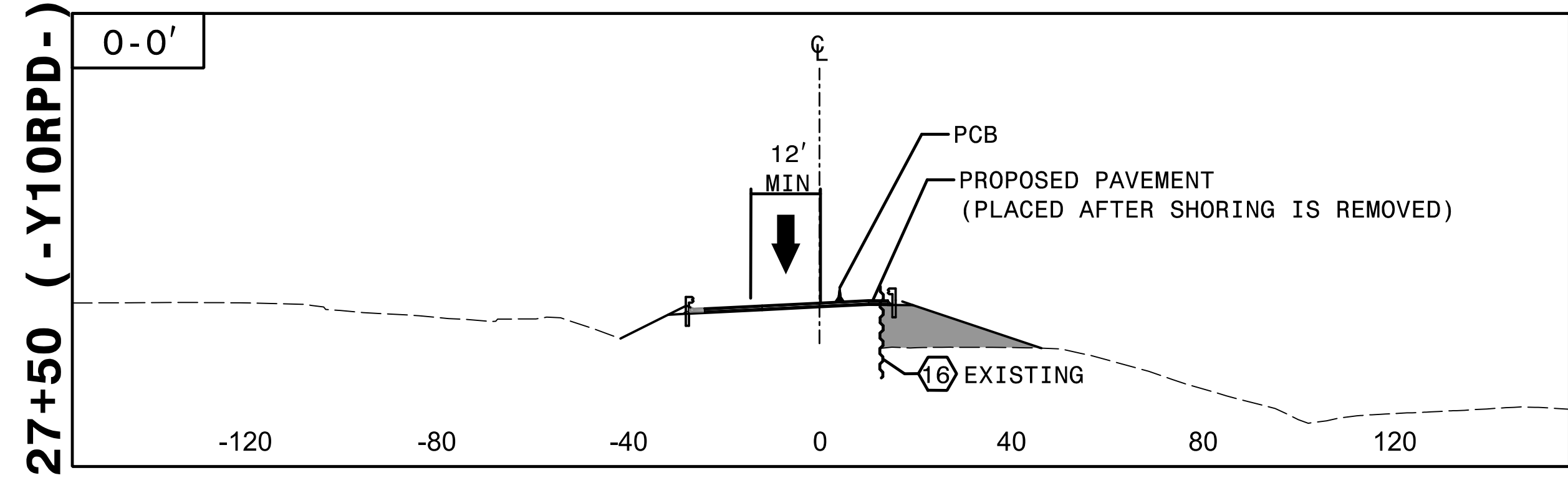
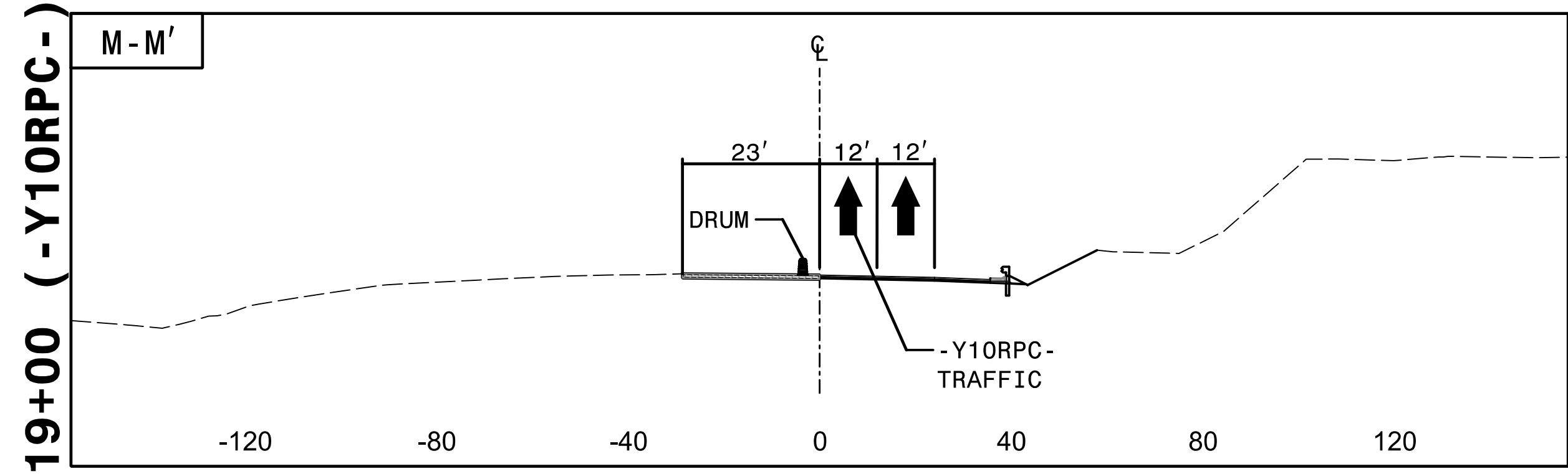
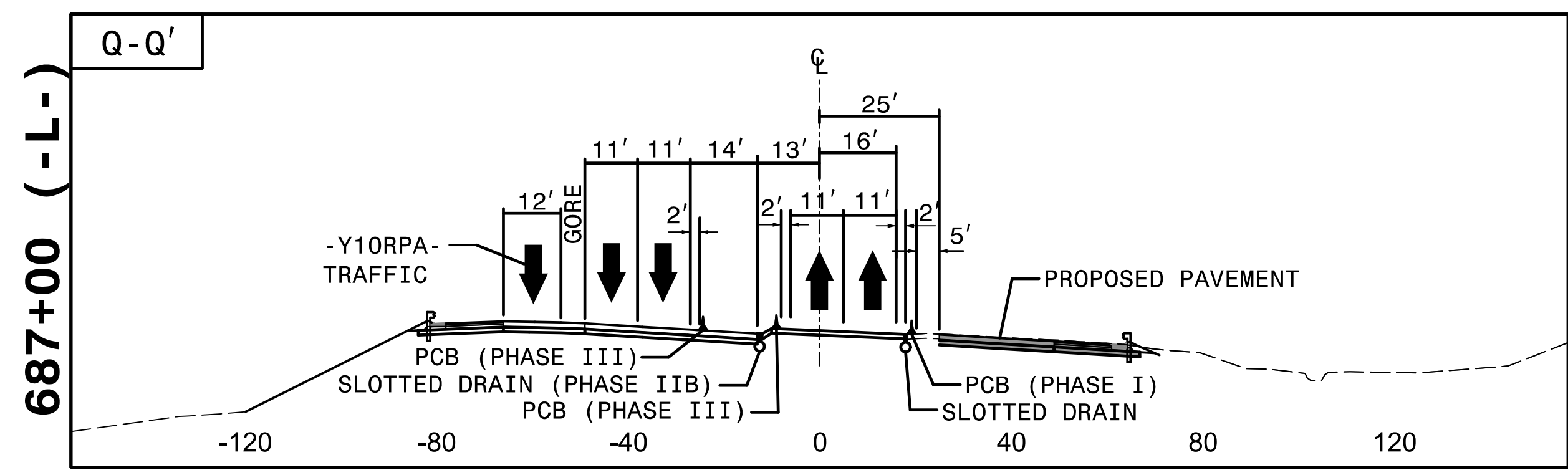
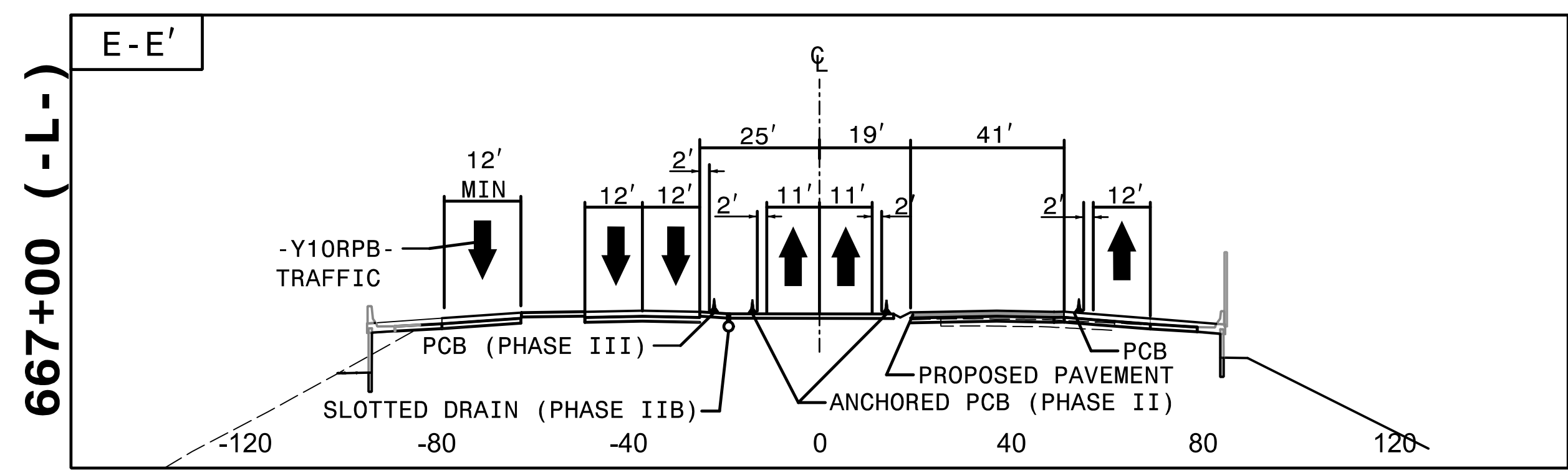

3:44:51PM
3:\TCN\4400C_fc_P3 CUTS.dgn
9/3/2019



DocuSigned by:
APPROVED: *Rhonda B. Early*
F3ACAF5ACDBF4BA.
DATE: 9/3/2019

**DOCUMENT NOT CONSIDERED FINAL
UNLESS ALL SIGNATURES COMPLETED**



TRANSPORTATION
MANAGEMENT PLAN

**PHASE IIIB
CUT SECTIONS**

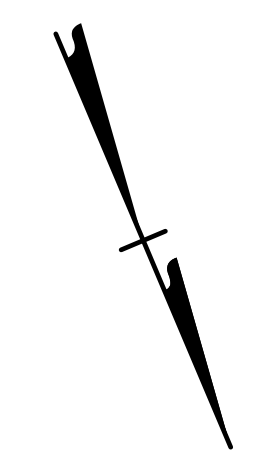
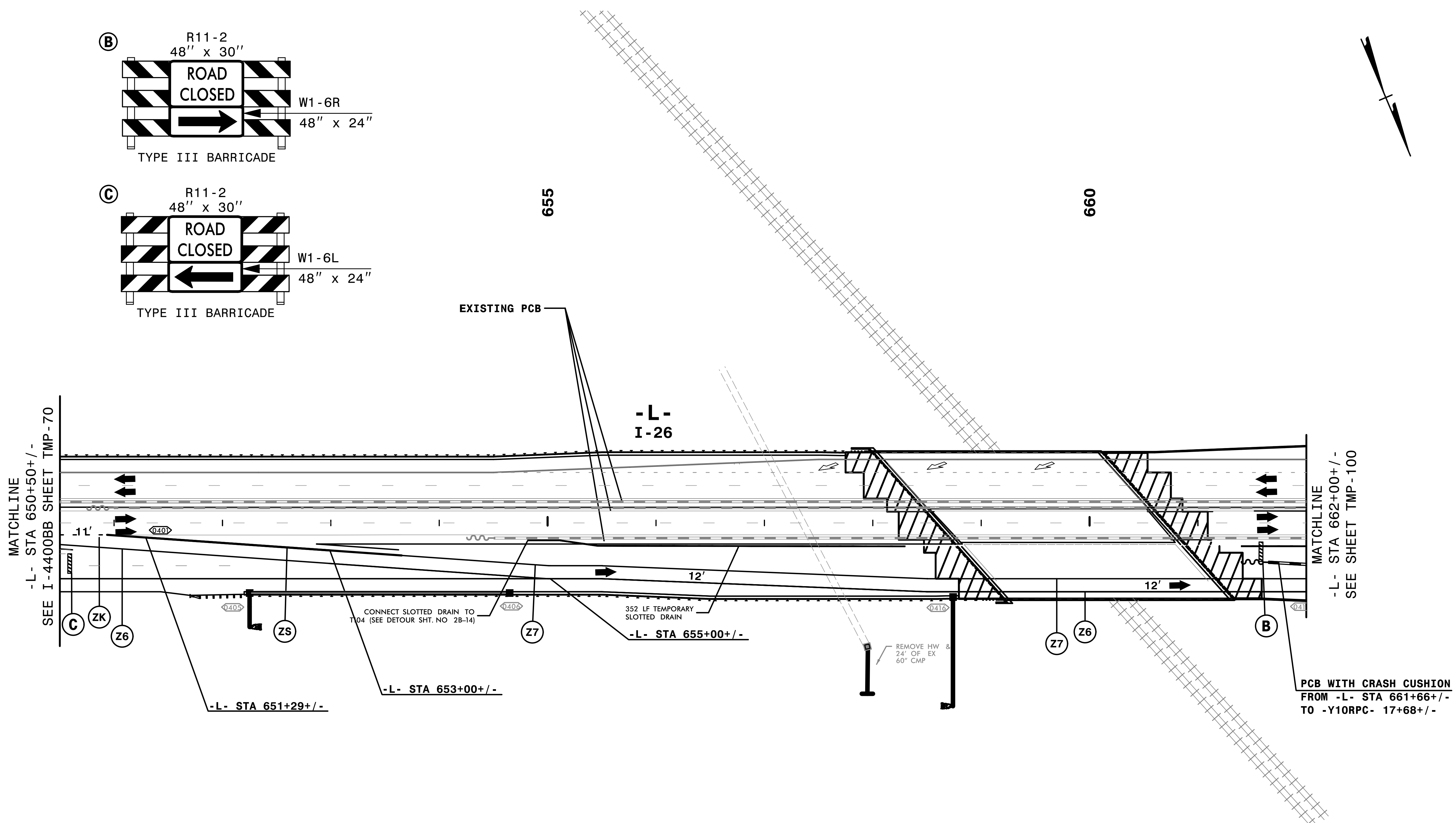
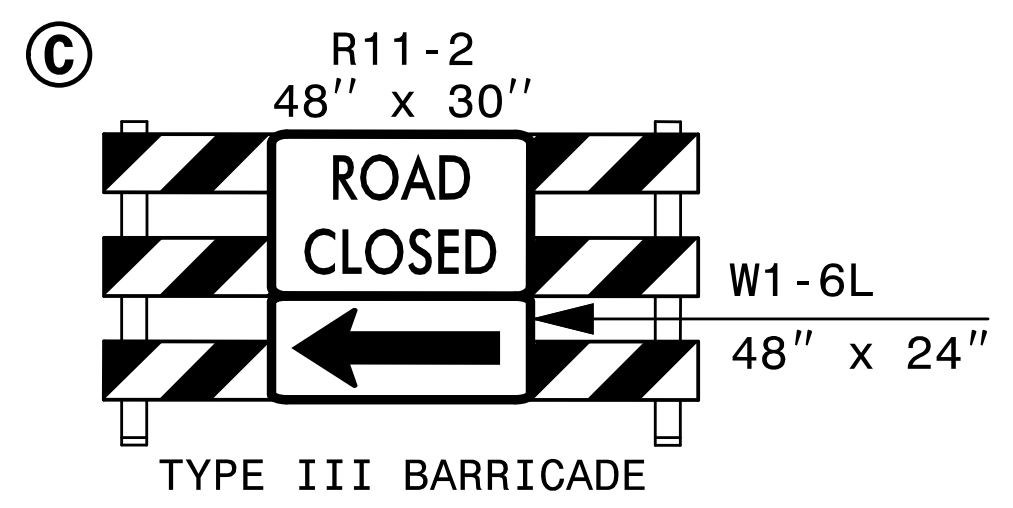
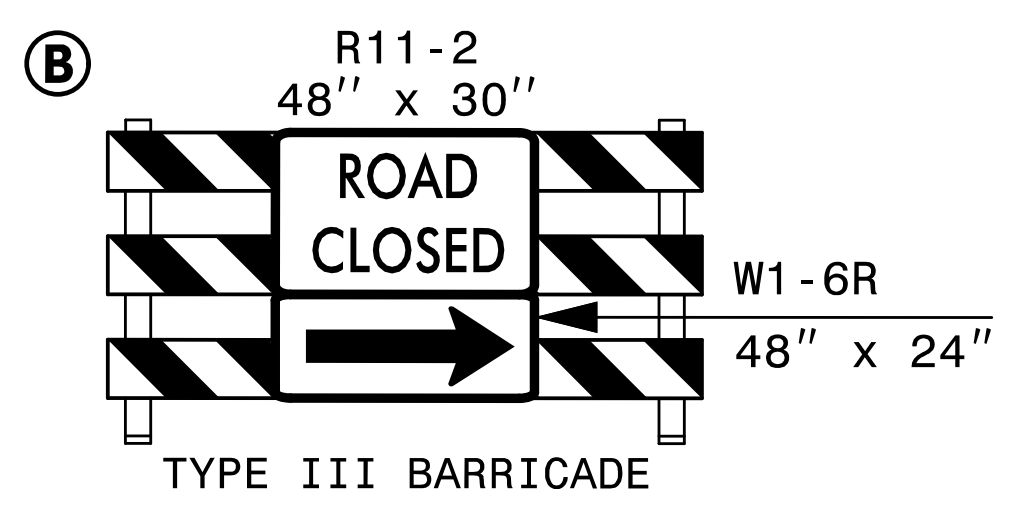

REMOVE CONFLICTING PAVEMENT MARKING.

3:45:20 PM
TCN\4400C-TC-ALP33bdl.dgn
9/3/2019

HNTB
HNTB NORTH CAROLINA, P.C.
343 E. Six Forks Road, Suite 200
Raleigh, North Carolina 27609
NC License No: C-1554

DocuSigned by:
Rhonda B. Early
APPROVED: Rhonda B. Early
F5MC4FSA08BF48A...
DATE: 9/3/2019

PROFESSIONAL ENGINEER SEAL
NORTH CAROLINA
023521
RHONDA B. EARLY

DOCUMENT NOT CONSIDERED FINAL UNLESS ALL SIGNATURES COMPLETED

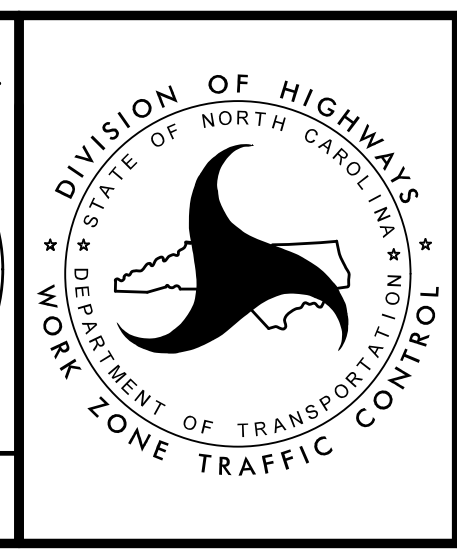

TRANSPORTATION
MANAGEMENT PLAN

PHASE IIIB
DETAIL

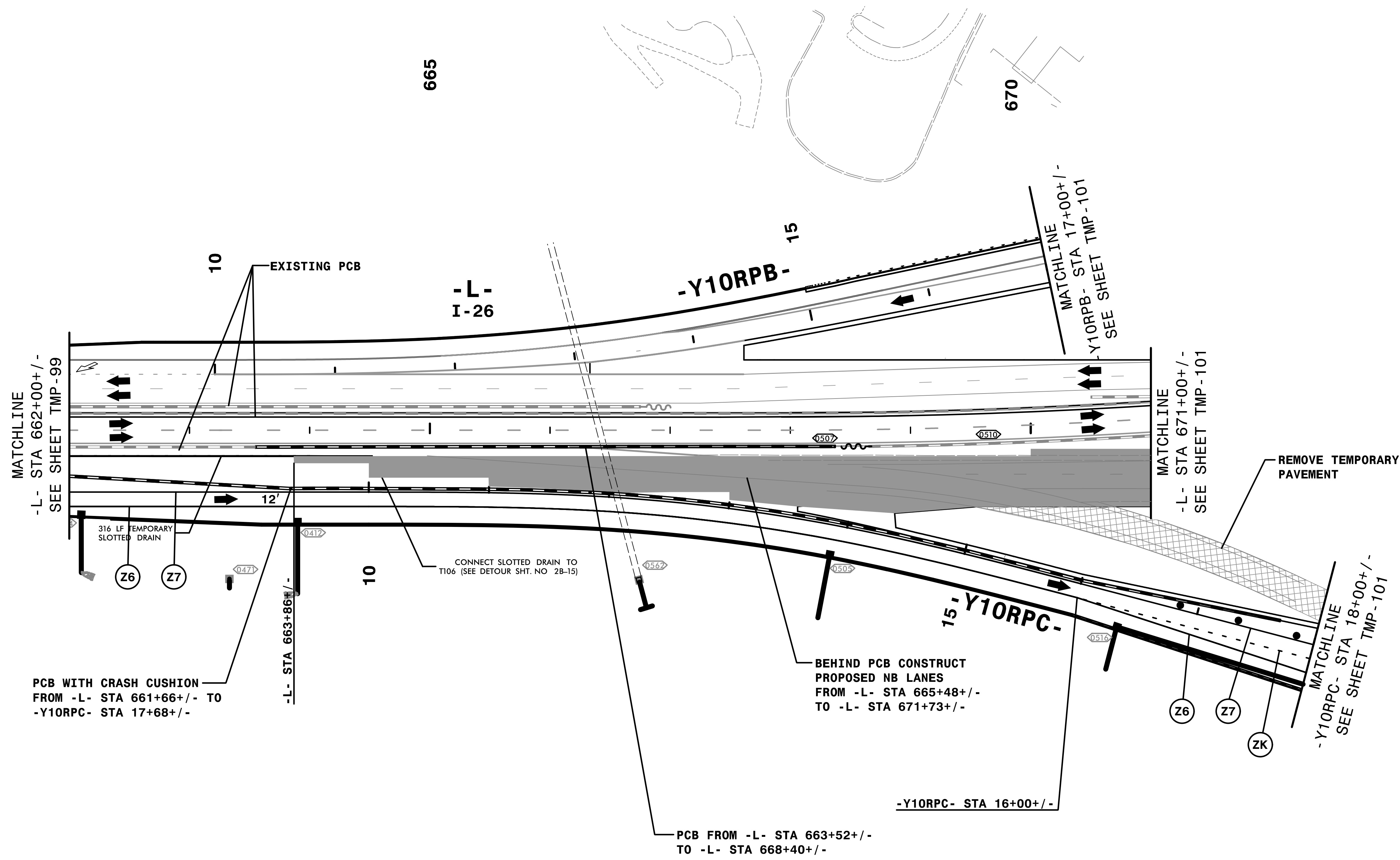
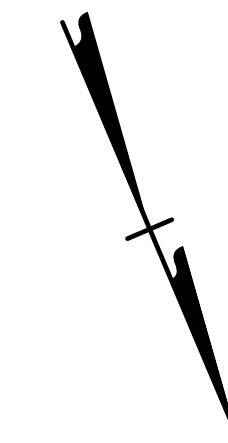

MATCHLINE
-L- STA 662+00+/-
SEE SHEET TMP-99

MATCHLINE
-L- STA 671+00+/-
SEE SHEET TMP-101

MATCHLINE
-Y10RCP- STA 18+00+/-
SEE SHEET TMP-101

PCB WITH CRASH CUSHION
FROM -L- STA 661+66+/- TO
-Y10RCP- STA 17+68+/-

BEHIND PCB CONSTRUCT
PROPOSED NB LANES
FROM -L- STA 665+48+/-
TO -L- STA 671+73+/-

PCB FROM -L- STA 663+52+/-
TO -L- STA 668+40+/-

REMOVE CONFLICTING PAVEMENT MARKING.

3:45:47 PM
TCN\4400C-1c_ALP3bd42.dgn
9/3/2019

HNTB HNTB NORTH CAROLINA, P.C.
343 E. SIX FORKS ROAD, SUITE 200
RALEIGH, NORTH CAROLINA 27609
NC LICENSE NO: C-1554

APPROVED: *Rhonda B. Early*
DATE: 9/3/2019

DocuSigned by:
Rhonda B. Early
F5MC4FSA08BF48A

PROFESSIONAL ENGINEER
NORTH CAROLINA
SEAL
023521
RHONDA B. EARLY

**DOCUMENT NOT CONSIDERED FINAL
UNLESS ALL SIGNATURES COMPLETED**

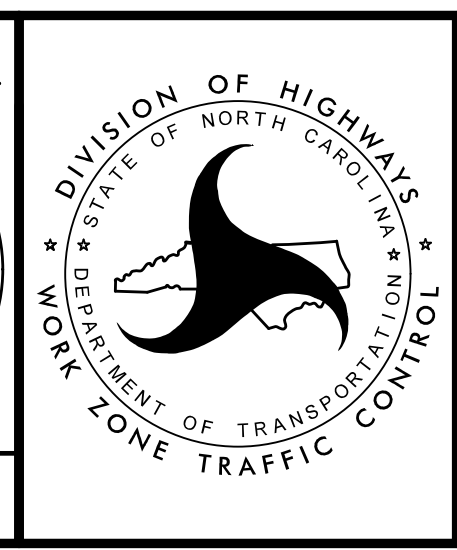

TRANSPORTATION
MANAGEMENT PLAN

PHASE IIIB
DETAIL

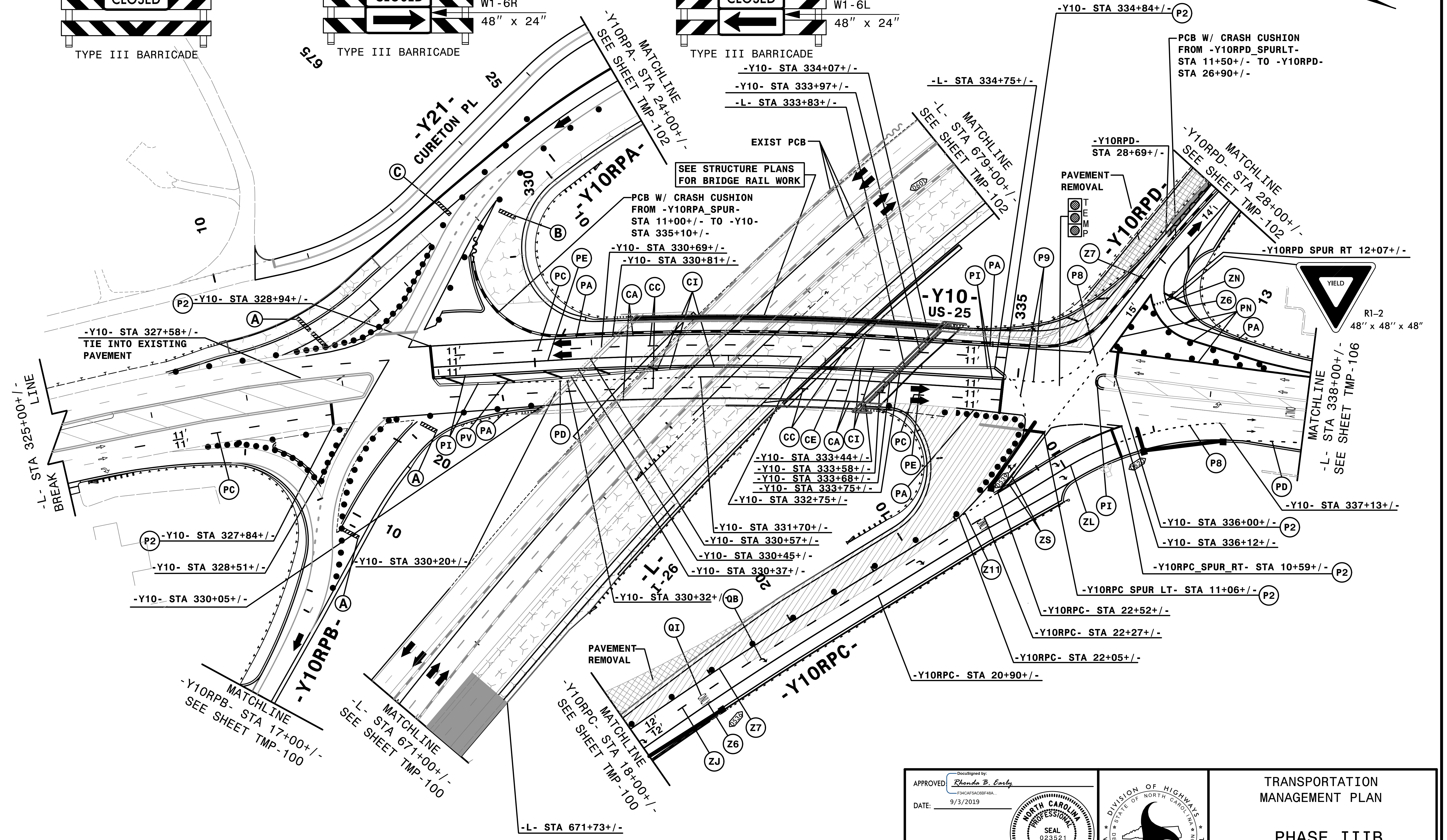
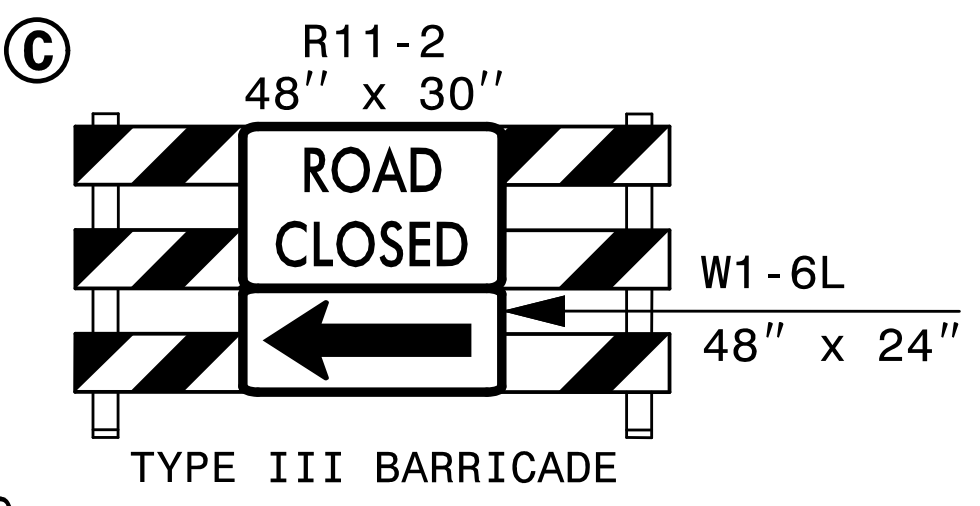
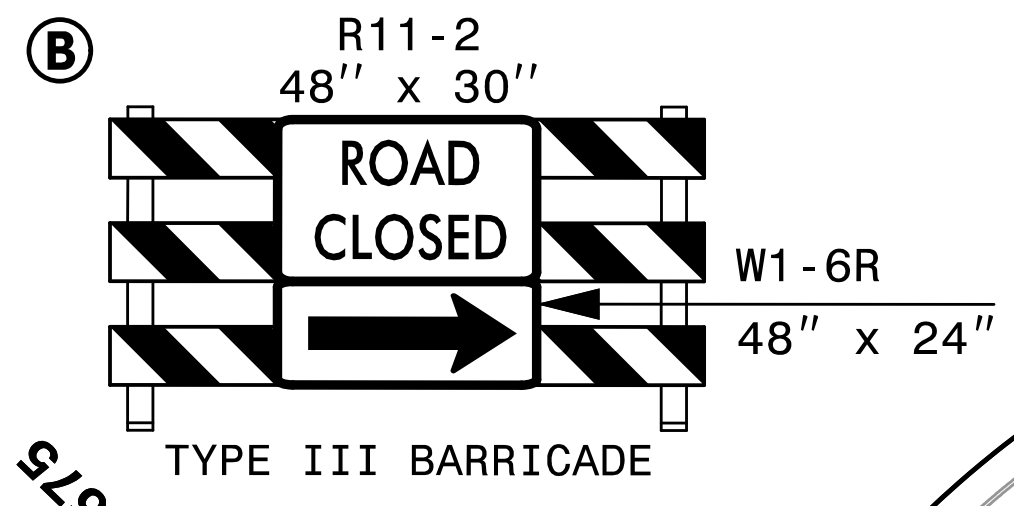
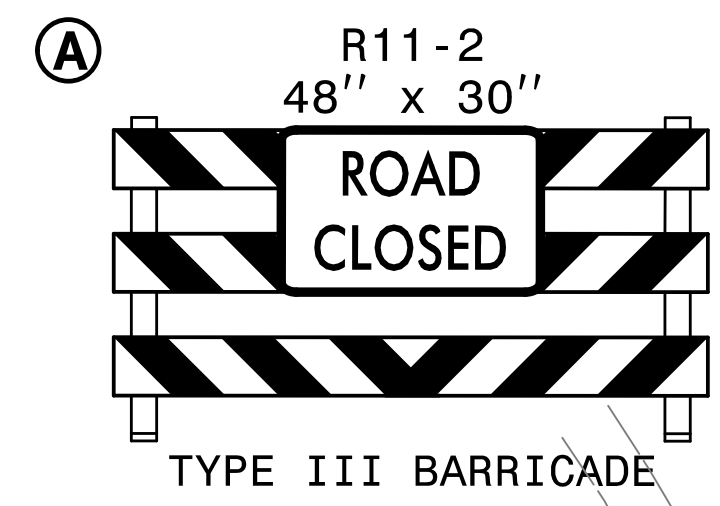

REMOVE CONFLICTING PAVEMENT MARKING.

3:46:17 PM
TC:\P\4400C-TC-ALP3b43.dgn
9/3/2019

HNTB
HNTB NORTH CAROLINA, P.C.
343 E. Six Forks Road, Suite 200
Raleigh, North Carolina 27609
NC License No: C-1554

APPROVED: *Rhonda B. Early*
DATE: 9/3/2019

DocuSigned by:
Rhonda B. Early
F5MC4F5AC0BF4BA

NORTH CAROLINA
PROFESSIONAL
ENGINEER
SEAL
023521
RHONDA B. EARLY

**DOCUMENT NOT CONSIDERED FINAL
UNLESS ALL SIGNATURES COMPLETED**



TRANSPORTATION
MANAGEMENT PLAN

PHASE IIIB
DETAIL

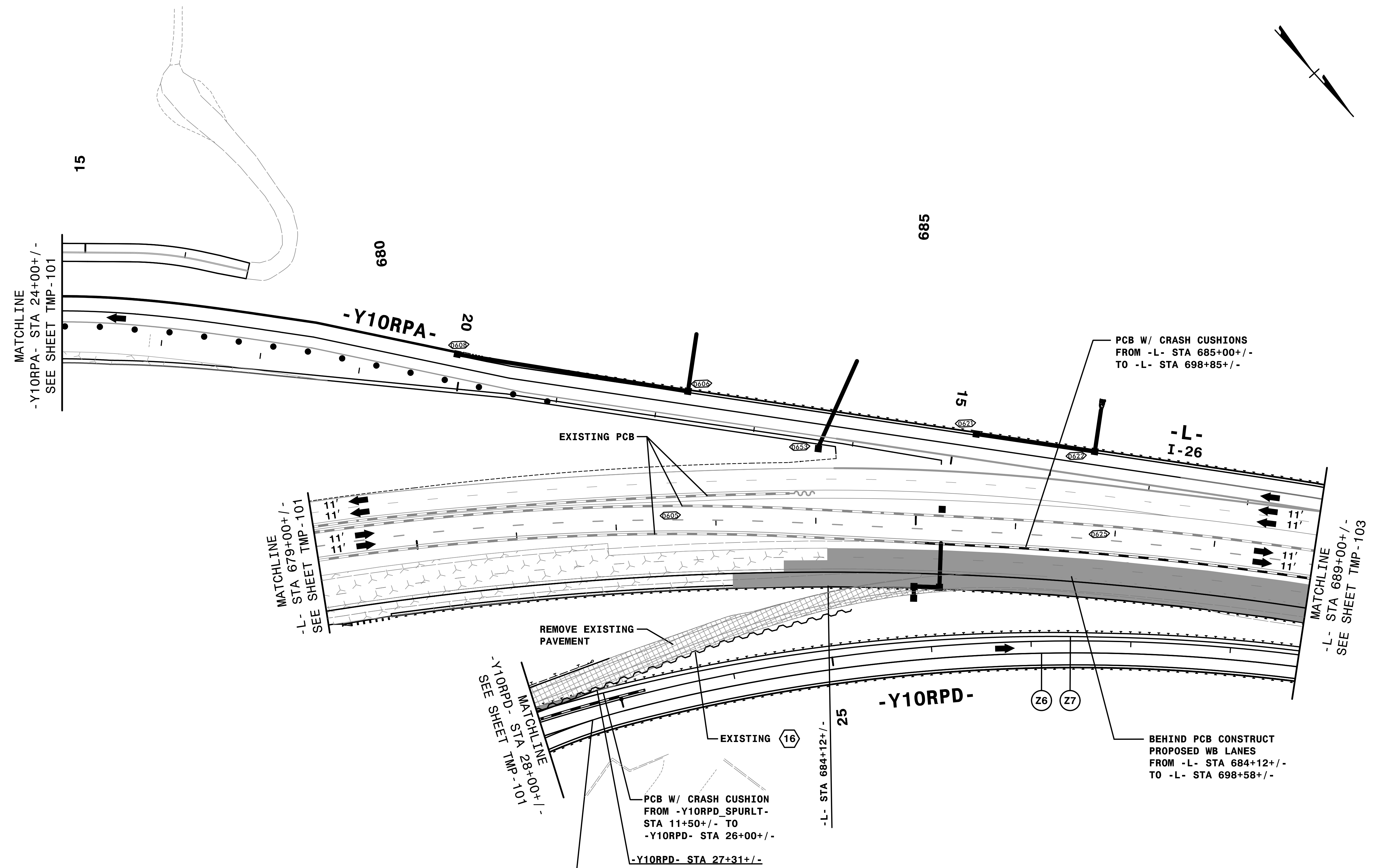
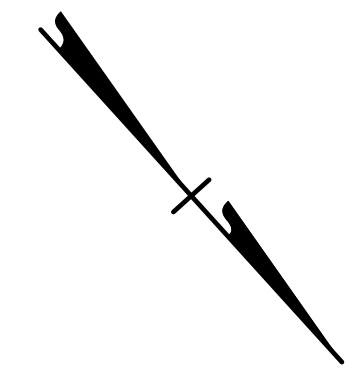

3:46:44 PM
 \\TCN\4400C-TC-ALP33bd4.dgn
 9/3/2019

-Y10RPD- STA 27+49+/-

MATCHLINE
 -Y10RPD- STA 28+00+/-
 SEE SHEET TMP-101

MATCHLINE
 -L- STA 689+00+/-
 SEE SHEET TMP-103

PCB W/ CRASH CUSHION
 FROM -Y10RPD- STA 11+50+/- TO
 -Y10RPD- STA 26+00+/-
 -Y10RPD- STA 27+31+/-

BEHIND PCB CONSTRUCT
 PROPOSED WB LANES
 FROM -L- STA 684+12+/-
 TO -L- STA 698+58+/-

HNTB
 HNTB NORTH CAROLINA, P.C.
 343 E. SIX FORKS ROAD, SUITE 200
 RALEIGH, NORTH CAROLINA 27609
 NC LICENSE NO: C-1554

APPROVED: *Rhonda B. Early*
 DATE: 9/3/2019
 NORTH CAROLINA PROFESSIONAL ENGINEER
 SEAL 023521
 RHONDA B. EARLY

**DOCUMENT NOT CONSIDERED FINAL
 UNLESS ALL SIGNATURES COMPLETED**

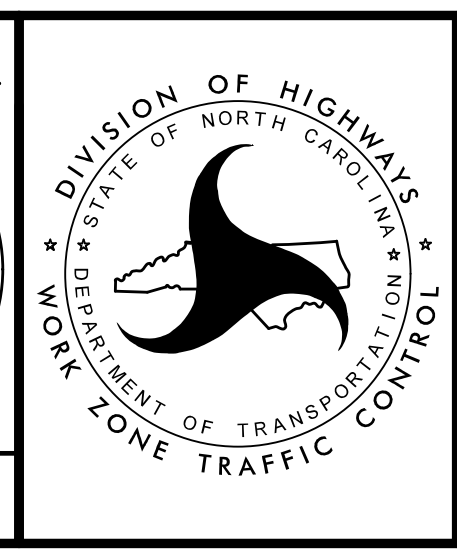

TRANSPORTATION
 MANAGEMENT PLAN

 PHASE IIIB
 DETAIL

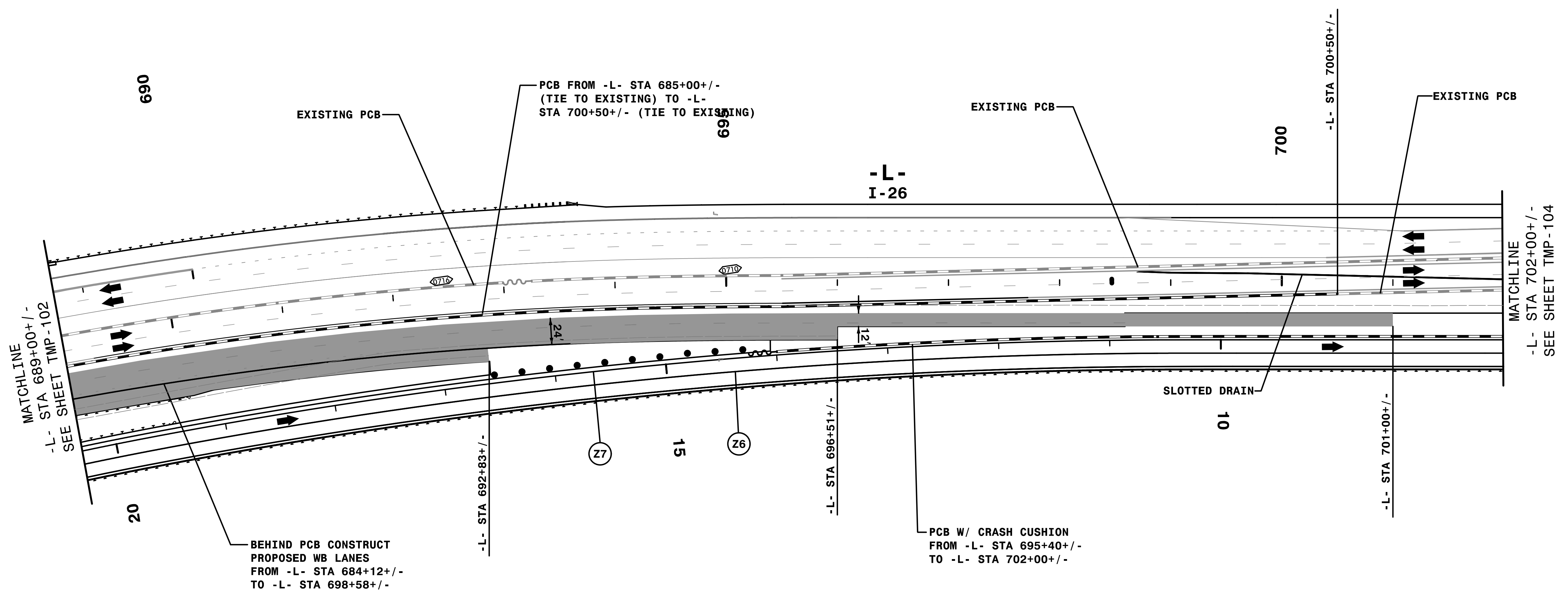
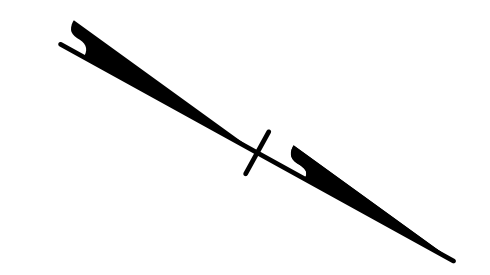

3:47:11 PM
 \\TCN\4400C-1c_AL.P3bd5.dgn
 9/3/2019



APPROVED: *Rhonda B. Early*
 DATE: 9/3/2019

DocuSigned by:
 Rhonda B. Early
 F5MC4FSA08BF48A

PROFESSIONAL ENGINEER
 NORTH CAROLINA
 SEAL
 023521
 RHONDA B. EARLY

**DOCUMENT NOT CONSIDERED FINAL
 UNLESS ALL SIGNATURES COMPLETED**

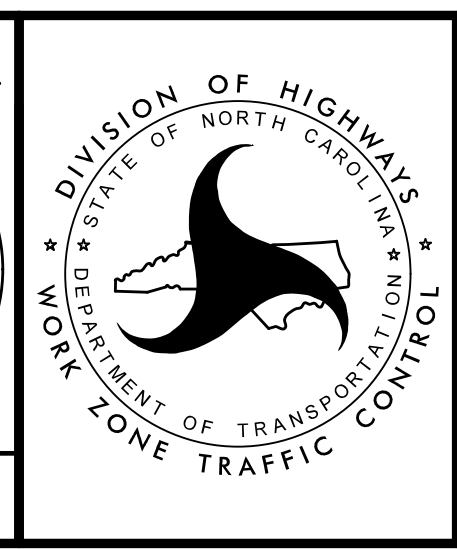

TRANSPORTATION
 MANAGEMENT PLAN

PHASE IIIB
 DETAIL

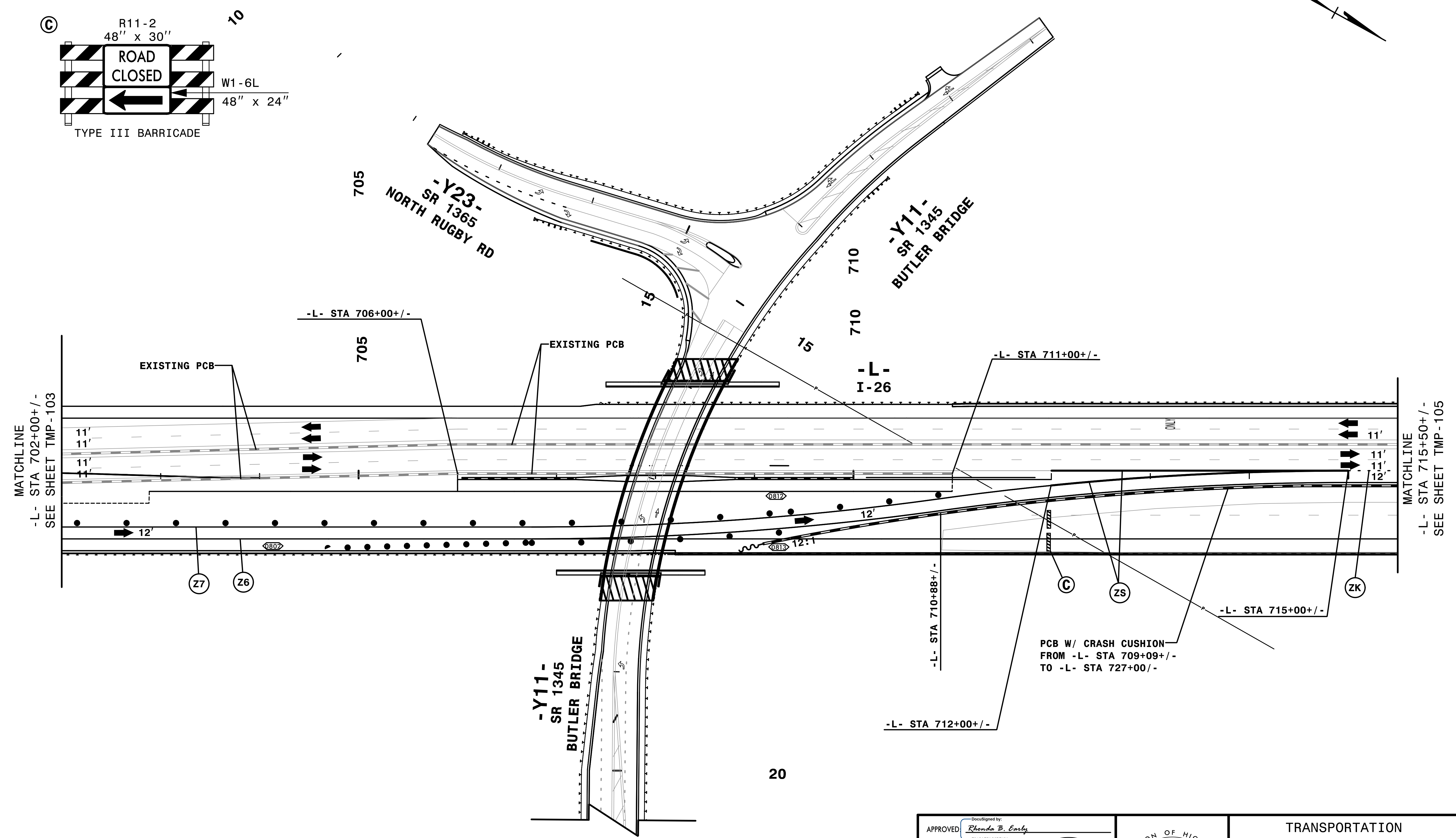
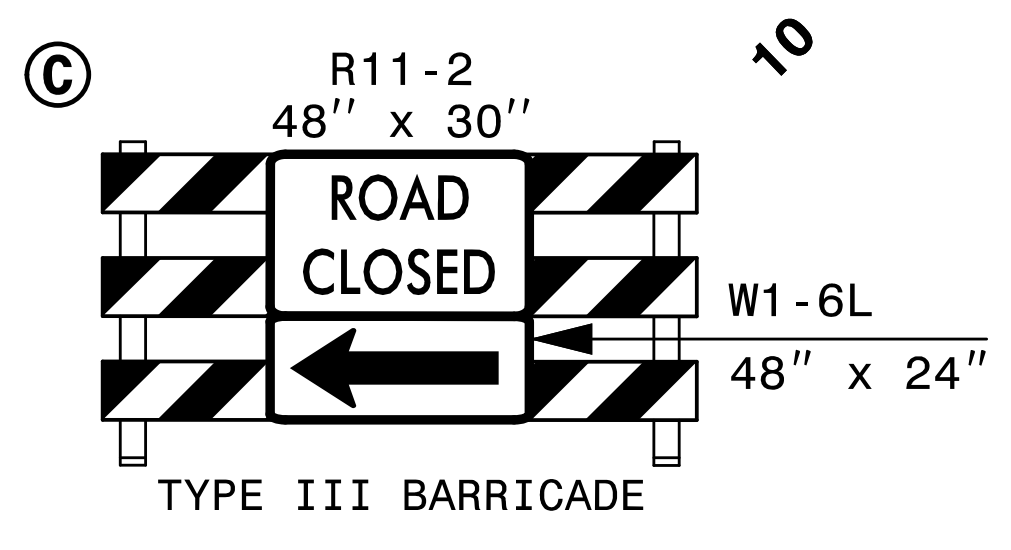

REMOVE CONFLICTING PAVEMENT MARKING.

3:47:37 PM
\\TCN\4400C-TC-A2-P3bdl.dgn
9/3/2019

HNTB
 HNTB NORTH CAROLINA, P.C.
 343 E. SIX FORKS ROAD, SUITE 200
 RALEIGH, NORTH CAROLINA 27609
 NC LICENSE NO: C-1554

DocuSigned by:
 APPROVED: *Rhonda B. Early*
 F5MC4FSA06BF48A
 DATE: 9/3/2019

PROFESSIONAL ENGINEER
 NORTH CAROLINA
 SEAL
 023521
 RHONDA B. EARLY

**DOCUMENT NOT CONSIDERED FINAL
 UNLESS ALL SIGNATURES COMPLETED**

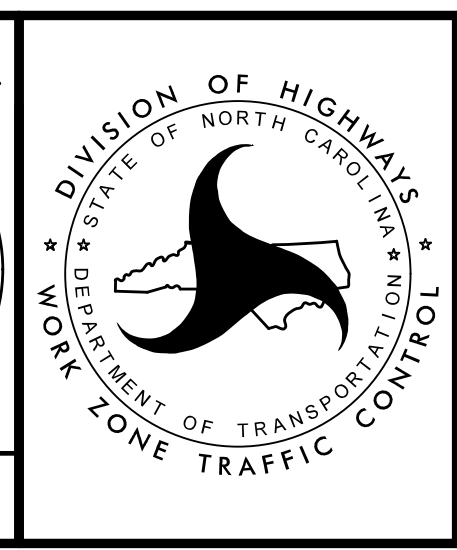

TRANSPORTATION
 MANAGEMENT PLAN

PHASE IIIB
 DETAIL

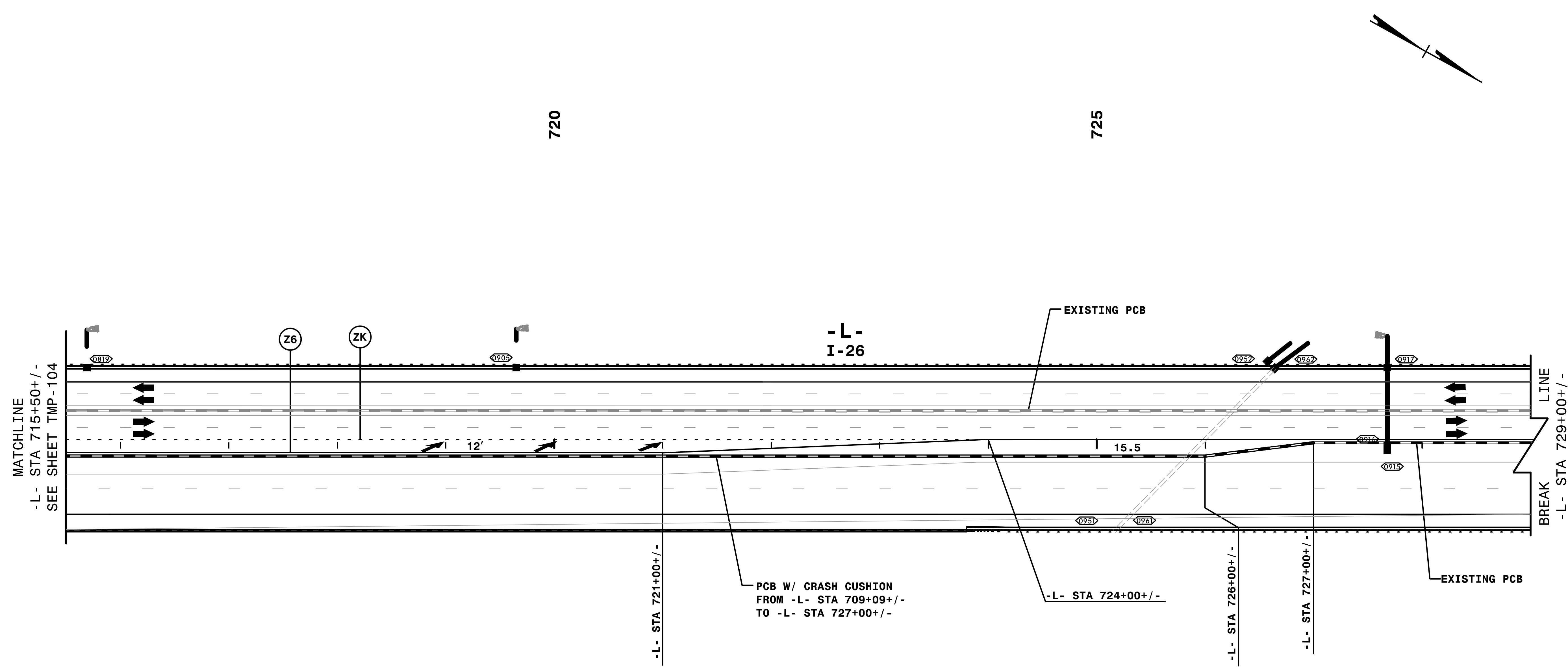

MATCHLINE
-L- STA 715+50+/-
SEE SHEET TMP-104

LINE
BREAK
-L- STA 729+00+/-

PCB W/ CRASH CUSHION
FROM -L- STA 709+09+/-
TO -L- STA 727+00+/-

-L- STA 724+00+/-

-L- STA 721+00+/-

-L- STA 726+00+/-

-L- STA 727+00+/-

EXISTING PCB

REMOVE CONFLICTING PAVEMENT MARKING.

3:48:03 PM
\\TCN\4400c_tc_A2_P3bd2.dgn
9/3/2019

HNTB
HNTB NORTH CAROLINA, P.C.
343 E. SIX FORKS ROAD, SUITE 200
RALEIGH, NORTH CAROLINA 27609
NC License No: C-1554

APPROVED: *Rhonda B. Early*
DATE: 9/3/2019
NORTH CAROLINA PROFESSIONAL ENGINEER SEAL 023521
RHONDA B. EARLY

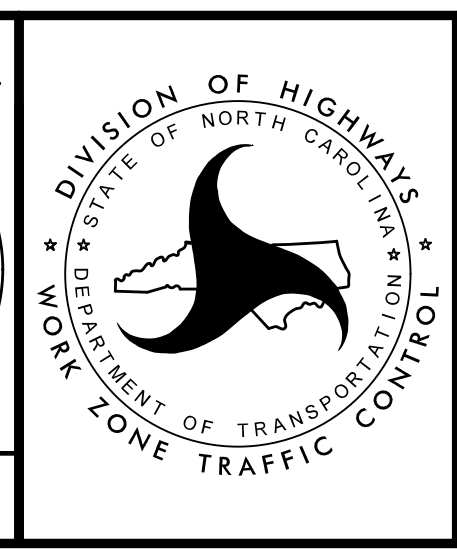

TRANSPORTATION
MANAGEMENT PLAN

PHASE IIIB
DETAIL

DOCUMENT NOT CONSIDERED FINAL
UNLESS ALL SIGNATURES COMPLETED

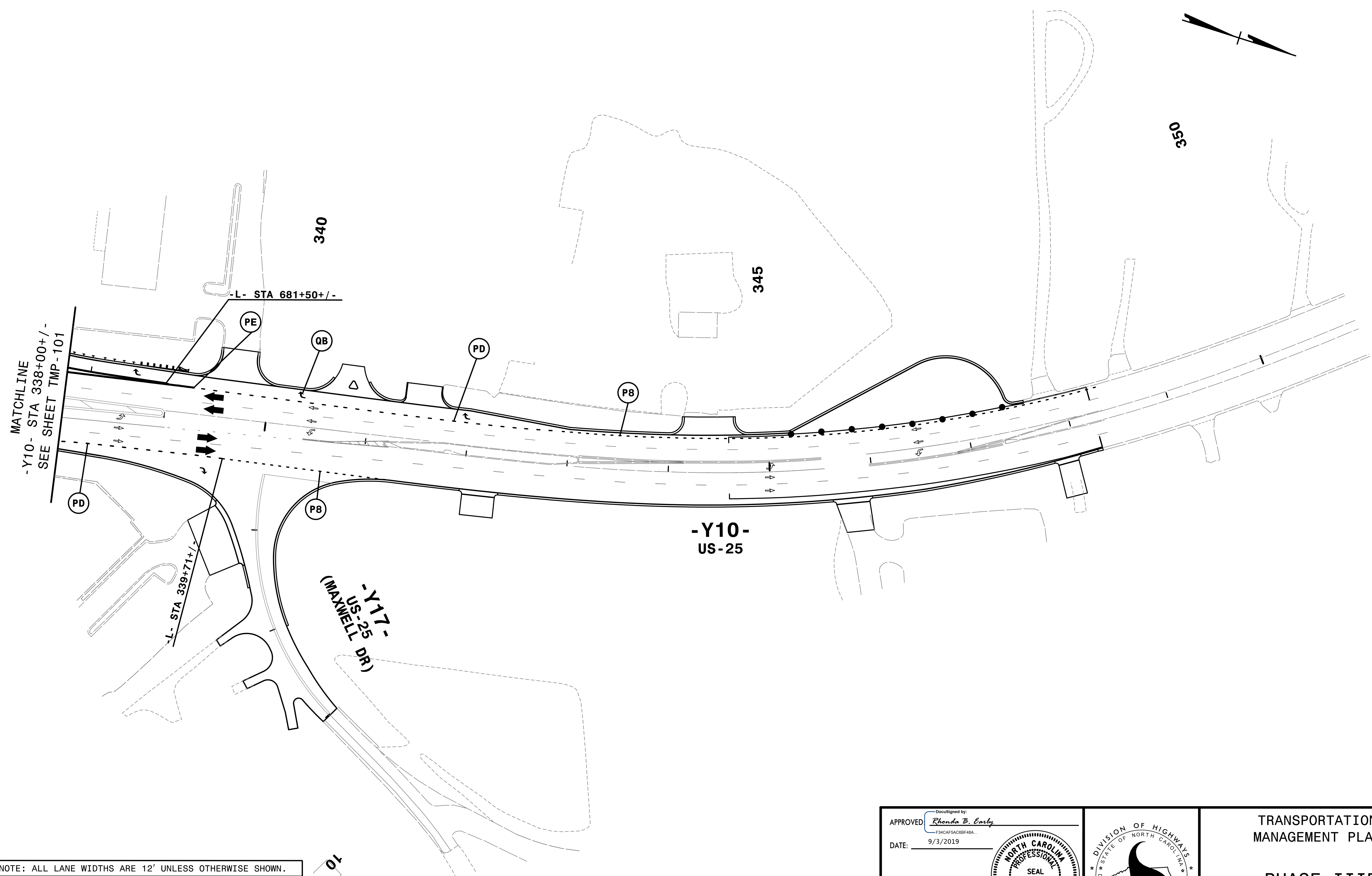

NOTE: ALL LANE WIDTHS ARE 12' UNLESS OTHERWISE SHOWN.

REMOVE CONFLICTING PAVEMENT MARKING.

10

HNTB HNTB NORTH CAROLINA, P.C.
 343 E. SIX FORKS ROAD, SUITE 200
 RALEIGH, NORTH CAROLINA 27609
 NC LICENSE NO: C-1554

APPROVED: *Rhonda B. Early*
DocuSigned by:
 Rhonda B. Early
 F5MC4FSA08BF48A

DATE: 9/3/2019

PROFESSIONAL ENGINEER SEAL
 NORTH CAROLINA
 023521
 RHONDA B. EARLY

**DOCUMENT NOT CONSIDERED FINAL
 UNLESS ALL SIGNATURES COMPLETED**

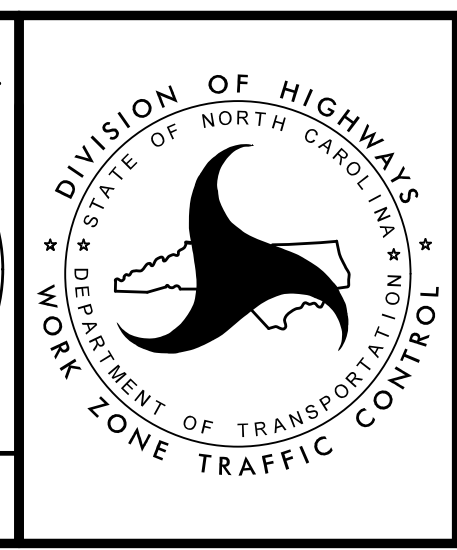

TRANSPORTATION
 MANAGEMENT PLAN

PHASE IIIB
 DETAIL

3:48:32 PM
 \\TCN\4400C-TC_ALP3Bd46.dgn
 9/3/2019

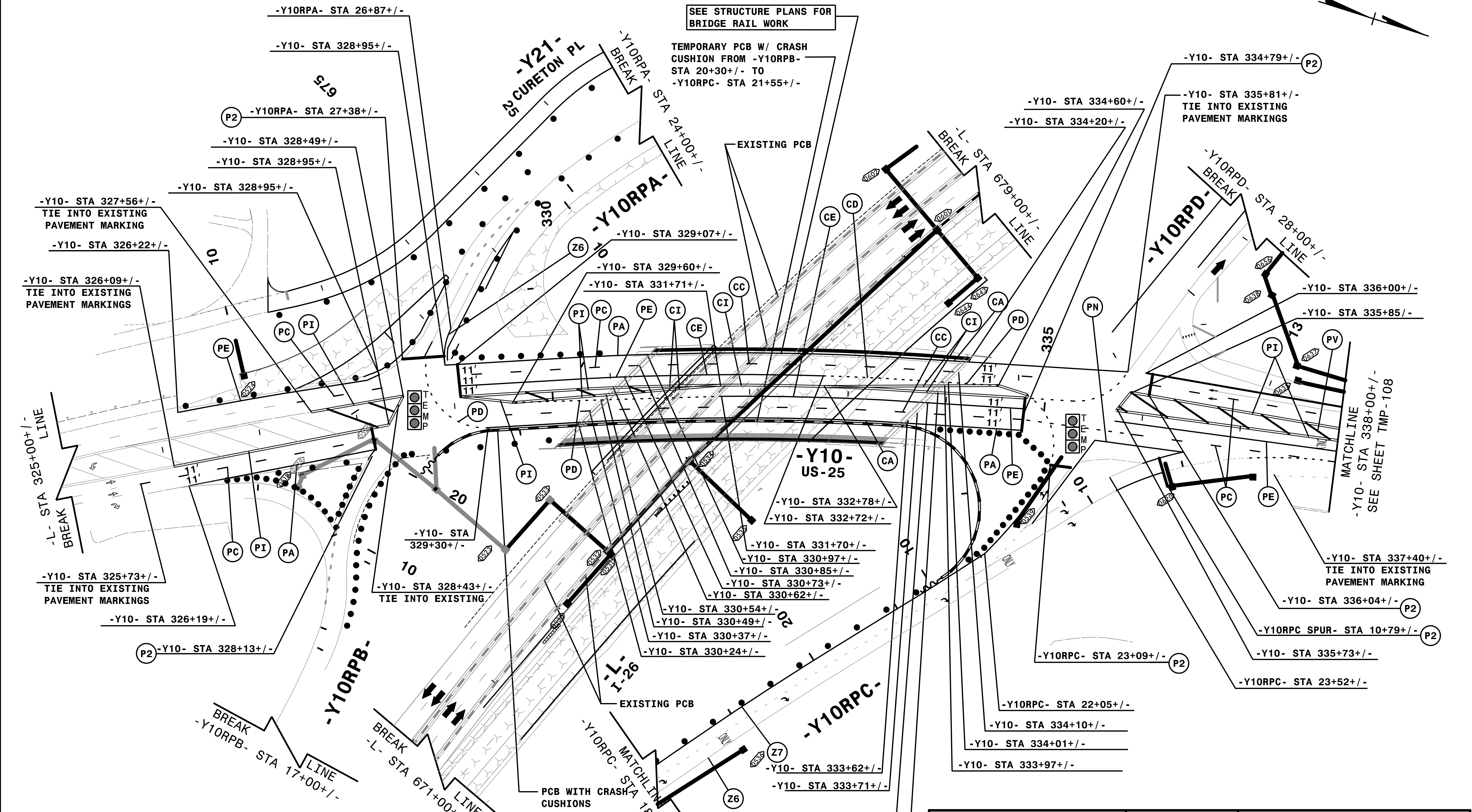
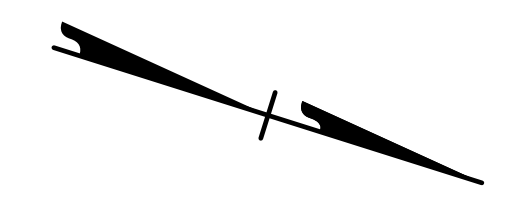

SEE STRUCTURE PLANS FOR
BRIDGE RAIL WORK

TEMPORARY PCB W/ CRASH
CUSHION FROM -Y10RPA-
STA 20+30+/- TO
-Y10RPC- STA 21+55+/-

EXISTING PCB

-Y10-
US-25

EXISTING PCB

PCB WITH CRASH
CUSHIONS

3:49:43 PM
 TCN\4400C-TC-ALP3C3d3.dgn
 9/3/2019

HNTB
 HNTB NORTH CAROLINA, P.C.
 343 E. Six Forks Road, Suite 200
 Raleigh, North Carolina 27609
 NC License No: C-1554

APPROVED: *Rhonda B. Early*
 DATE: 9/3/2019

DocuSigned by:
 Rhonda B. Early
 F5MC4FSA06F48A

DATE: 9/3/2019

PROFESSIONAL ENGINEER
 NORTH CAROLINA
 SEAL
 023521
 RHONDA B. EARLY

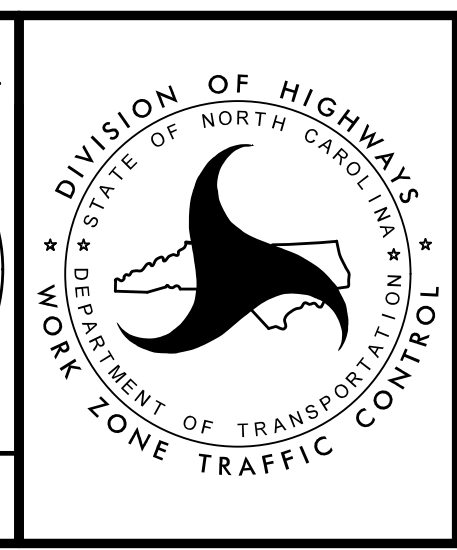

TRANSPORTATION
MANAGEMENT PLAN

PHASE IIIC
DETAIL

DOCUMENT NOT CONSIDERED FINAL
UNLESS ALL SIGNATURES COMPLETED

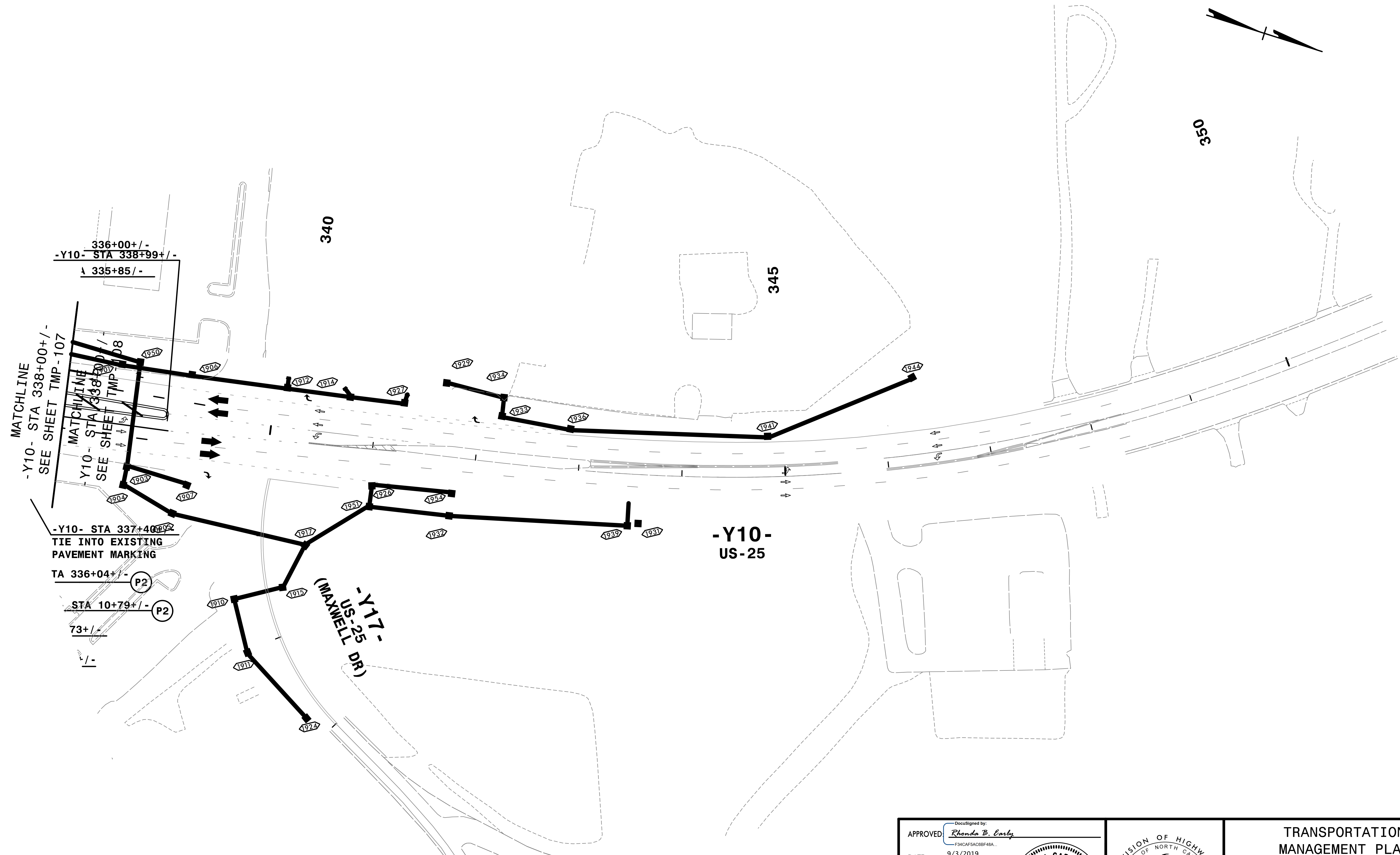

NOTE: ALL LANE WIDTHS ARE 12' UNLESS OTHERWISE SHOWN.

REMOVE CONFLICTING PAVEMENT MARKING.

3:50:49 PM
 \\TCN\4400C-TC_ALP3C4d46.dgn
 9/3/2019

HNTB
 HNTB NORTH CAROLINA, P.C.
 343 E. SIX FORKS ROAD, SUITE 200
 RALEIGH, NORTH CAROLINA 27609
 NC LICENSE NO: C-1554

DocuSigned by:
Rhonda B. Early
 F5MC4FSA08BF48A

APPROVED: _____
 DATE: 9/3/2019

PROFESSIONAL ENGINEER
 NORTH CAROLINA
 SEAL
 023521
 RHONDA B. EARLY

**DOCUMENT NOT CONSIDERED FINAL
 UNLESS ALL SIGNATURES COMPLETED**

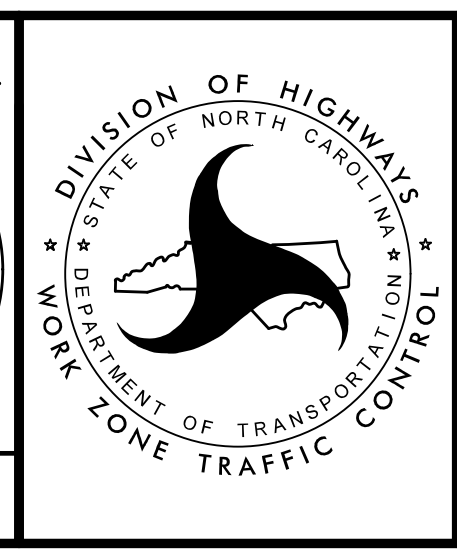

TRANSPORTATION
 MANAGEMENT PLAN

PHASE IIIC
 DETAIL

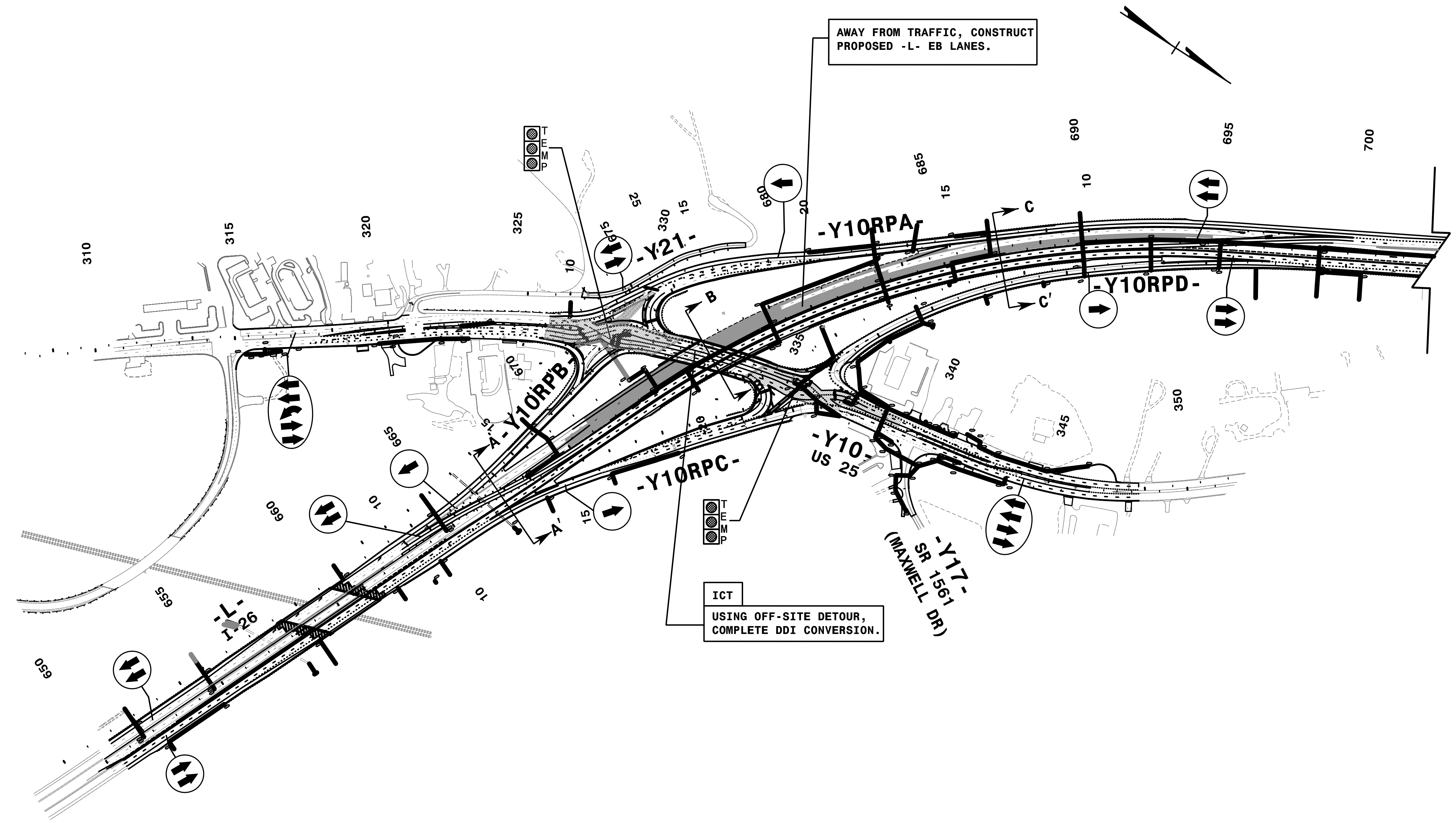

3:54:55 PM
 \\TCN\4400C-1c_PHASE_4_OV.dgn
 9/3/2019

REFER TO SHEET TMP-112 FOR CUT SECTION(S).

HNTB
 HNTB NORTH CAROLINA, P.C.
 343 E. Six Forks Road, Suite 200
 Raleigh, North Carolina 27609
 NC License No: C-1554

APPROVED: *Rhonda B. Early*
 DATE: 9/3/2019

DocuSigned by:
 Rhonda B. Early
 F3ACAF8AC0BF4BA

NORTH CAROLINA
 PROFESSIONAL
 SEAL
 023521
 ENGINEER
 RHONDA B. EARLY

**DOCUMENT NOT CONSIDERED FINAL
 UNLESS ALL SIGNATURES COMPLETED**



TRANSPORTATION
 MANAGEMENT PLAN

PHASE IV
 OVERVIEW

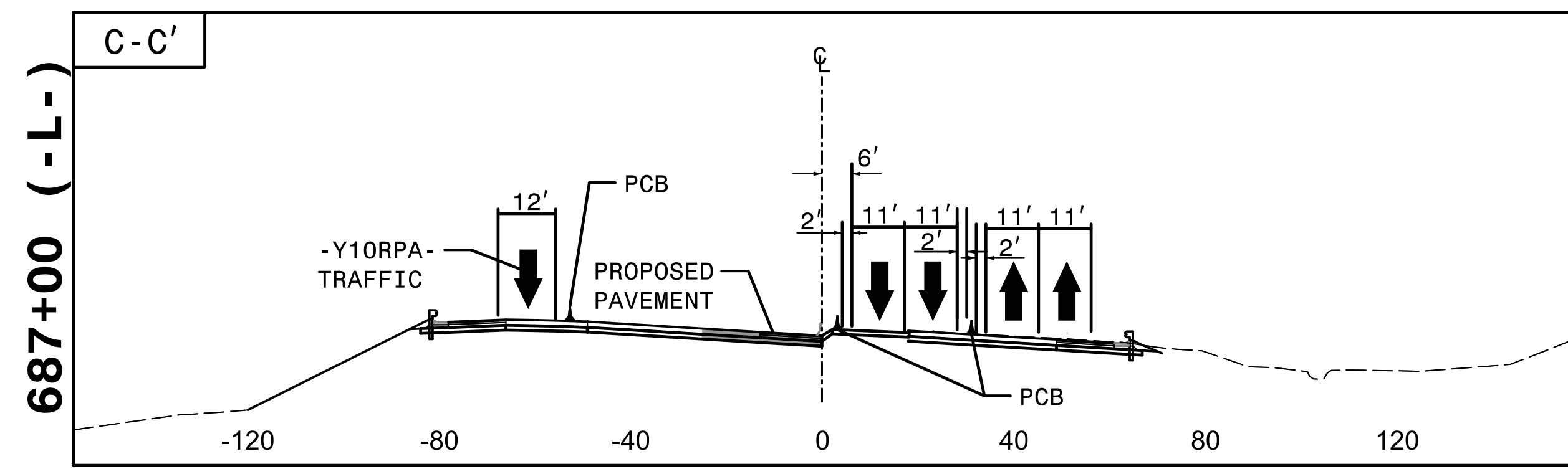
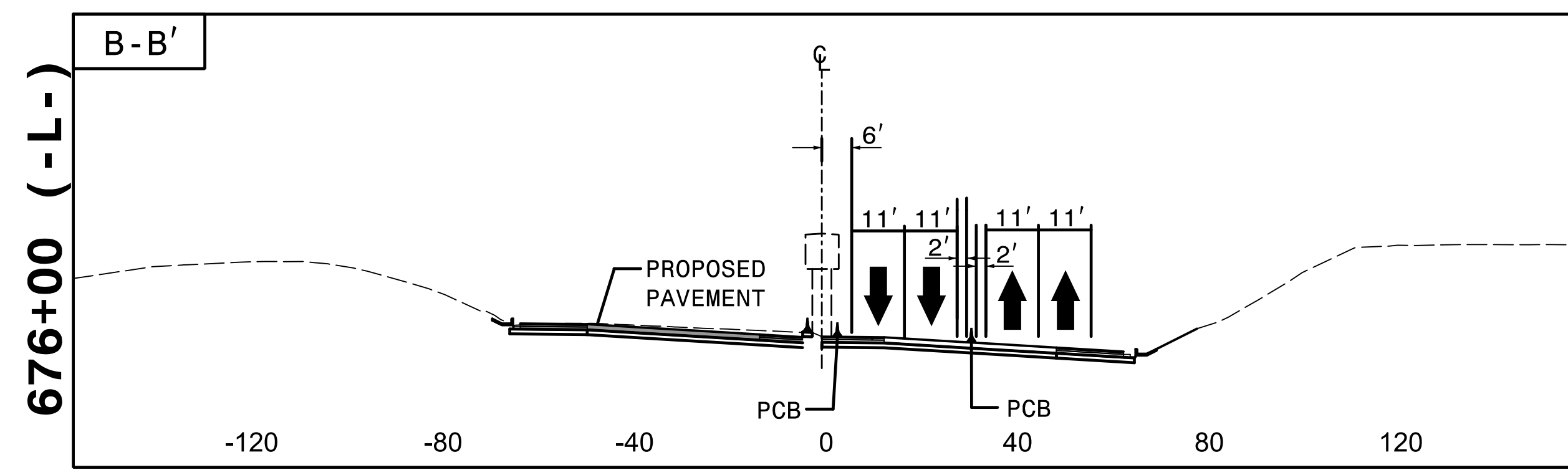
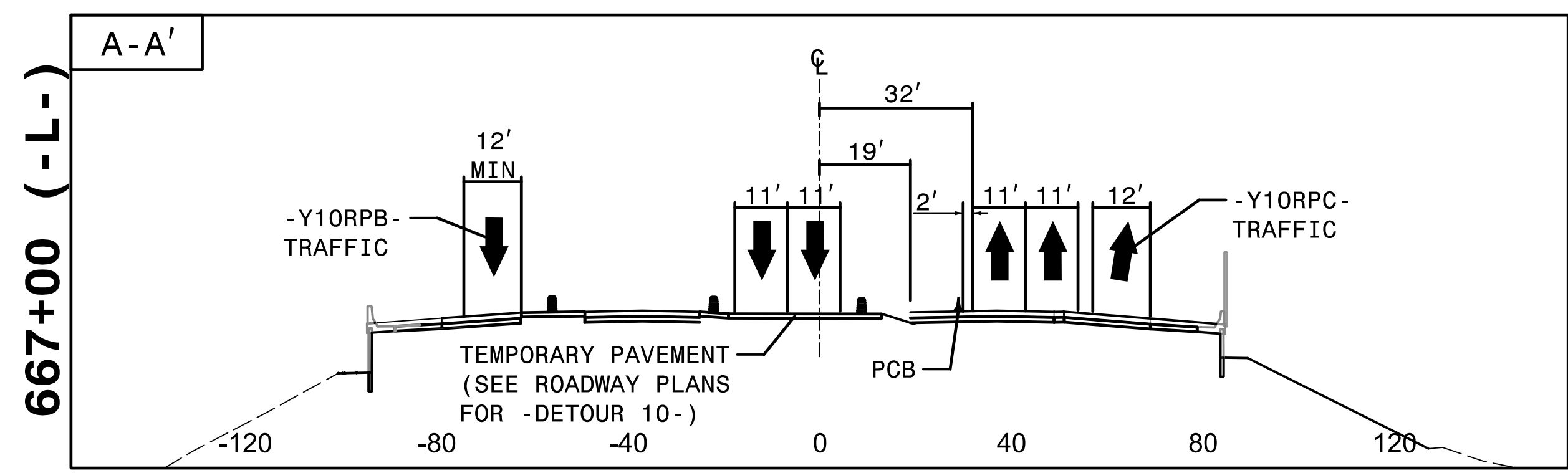

3:55:52 PM
\\TCB\14400C_Tc_P4 CUTS.dgn
\$\$\$\$\$USERNAME\$\$\$\$\$

HNTB HNTB NORTH CAROLINA, P.C.
343 E. Six Forks Road, Suite 200
Raleigh, North Carolina 27609
NC License No: C-1554

DESIGNED BY: Rhonda B. Early
APPROVED: *Rhonda B. Early*
F3ACAF5AC0BF48A
DATE: 9/3/2019

SEAL

**DOCUMENT NOT CONSIDERED FINAL
UNLESS ALL SIGNATURES COMPLETED**



TRANSPORTATION
MANAGEMENT PLAN

PHASE IV
CUT SECTIONS

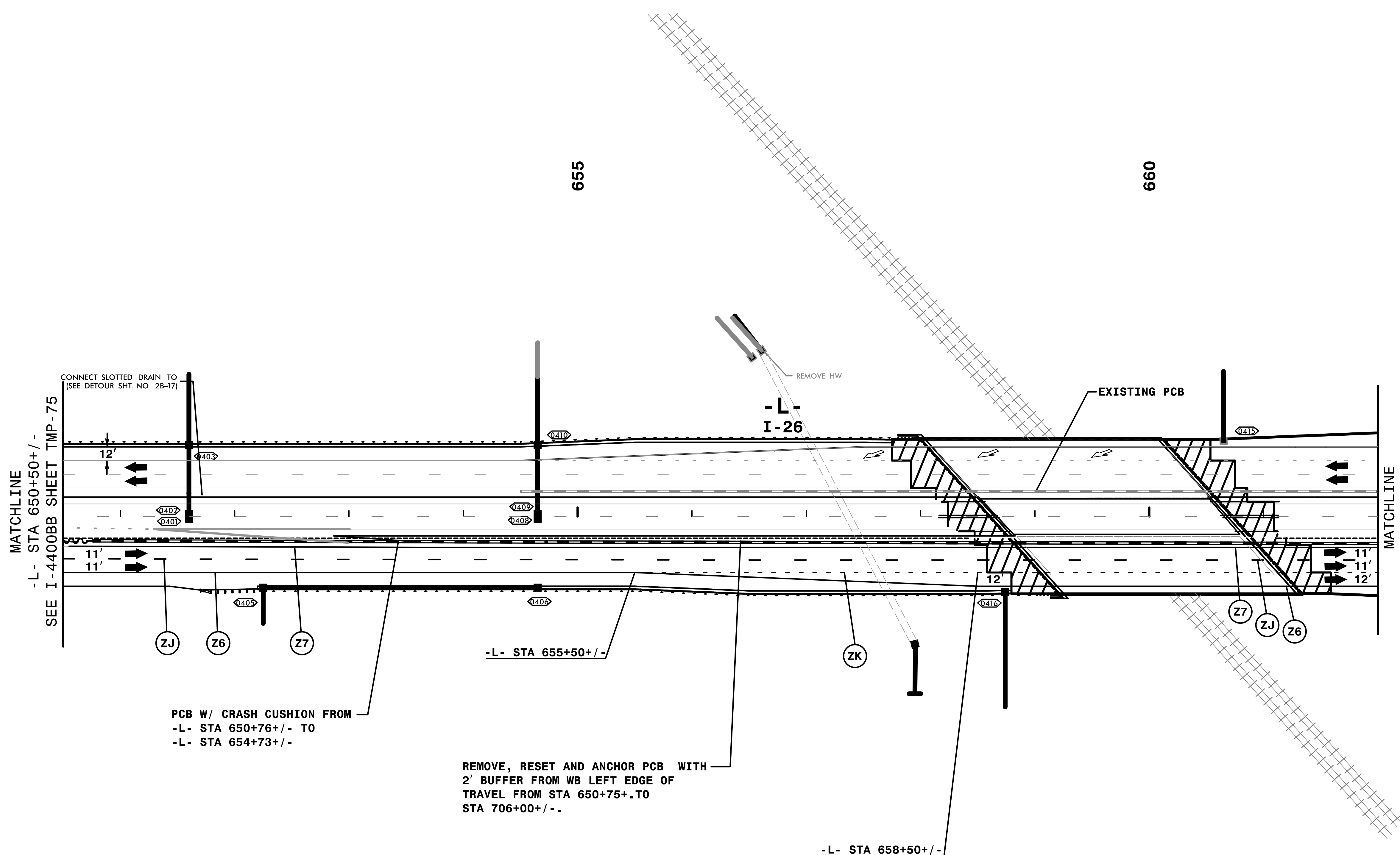
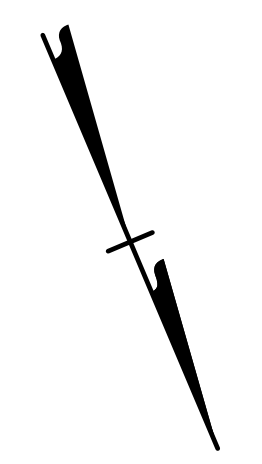

REMOVE CONFLICTING PAVEMENT MARKING.

3:56:30 PM
 \\TCN\4400C-TC-ALP4.dgn
 9/3/2019

HNTB HNTB NORTH CAROLINA, P.C.
 343 E. Six Forks Road, Suite 200
 Raleigh, North Carolina 27609
 NC License No: C-1554

APPROVED: *Rhonda B. Early*
 DATE: 9/3/2019

DocuSigned by:
 Rhonda B. Early
 F3ACAF5AC0BF4BA

SEAL
 NORTH CAROLINA
 PROFESSIONAL
 ENGINEER
 023521
 RHONDA B. EARLY

**DOCUMENT NOT CONSIDERED FINAL
 UNLESS ALL SIGNATURES COMPLETED**

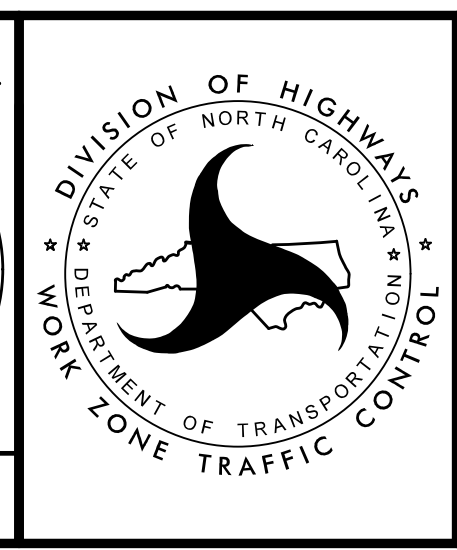

TRANSPORTATION
 MANAGEMENT PLAN

PHASE IV
 DETAIL

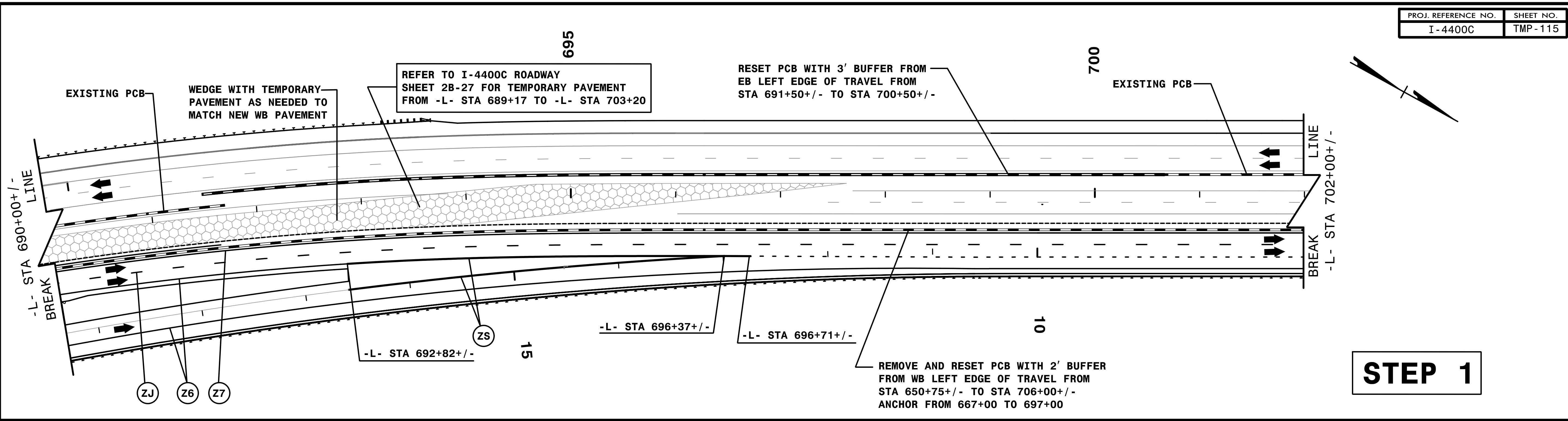

STEP 1

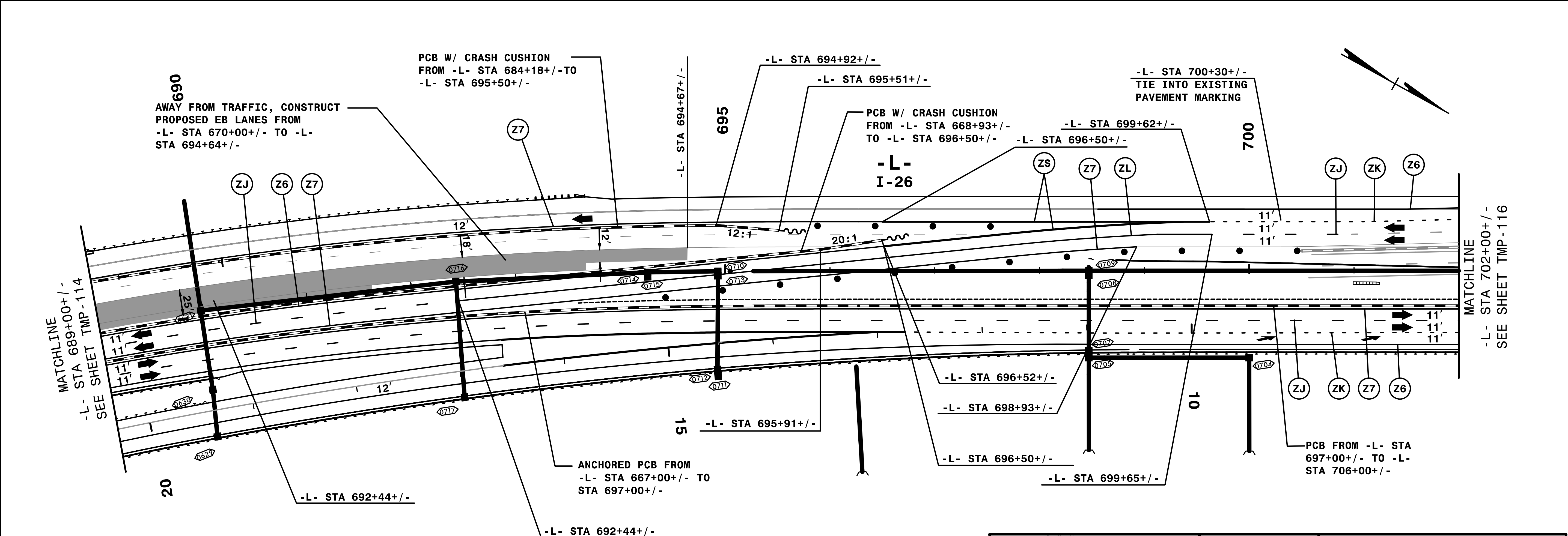

REMOVE CONFLICTING PAVEMENT MARKING.

3:58:32 PM
\\TCN\4400C-TC_ALP4d5.dgn
9/3/2019

HNTB
 HNTB NORTH CAROLINA, P.C.
 343 E. Six Forks Road, Suite 200
 Raleigh, North Carolina 27609
 NC License No: C-1554

APPROVED: *Rhonda B. Early*
 DATE: 9/3/2019
 NORTH CAROLINA PROFESSIONAL ENGINEER
 SEAL 023521
 RHONDA B. EARLY

DIVISION OF HIGHWAYS
 STATE OF NORTH CAROLINA
 DEPARTMENT OF TRANSPORTATION
 WORK ZONE TRAFFIC CONTROL

TRANSPORTATION MANAGEMENT PLAN
 PHASE IV DETAIL

DOCUMENT NOT CONSIDERED FINAL UNLESS ALL SIGNATURES COMPLETED

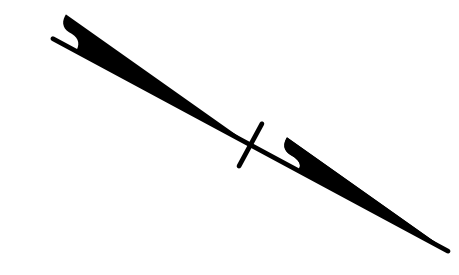
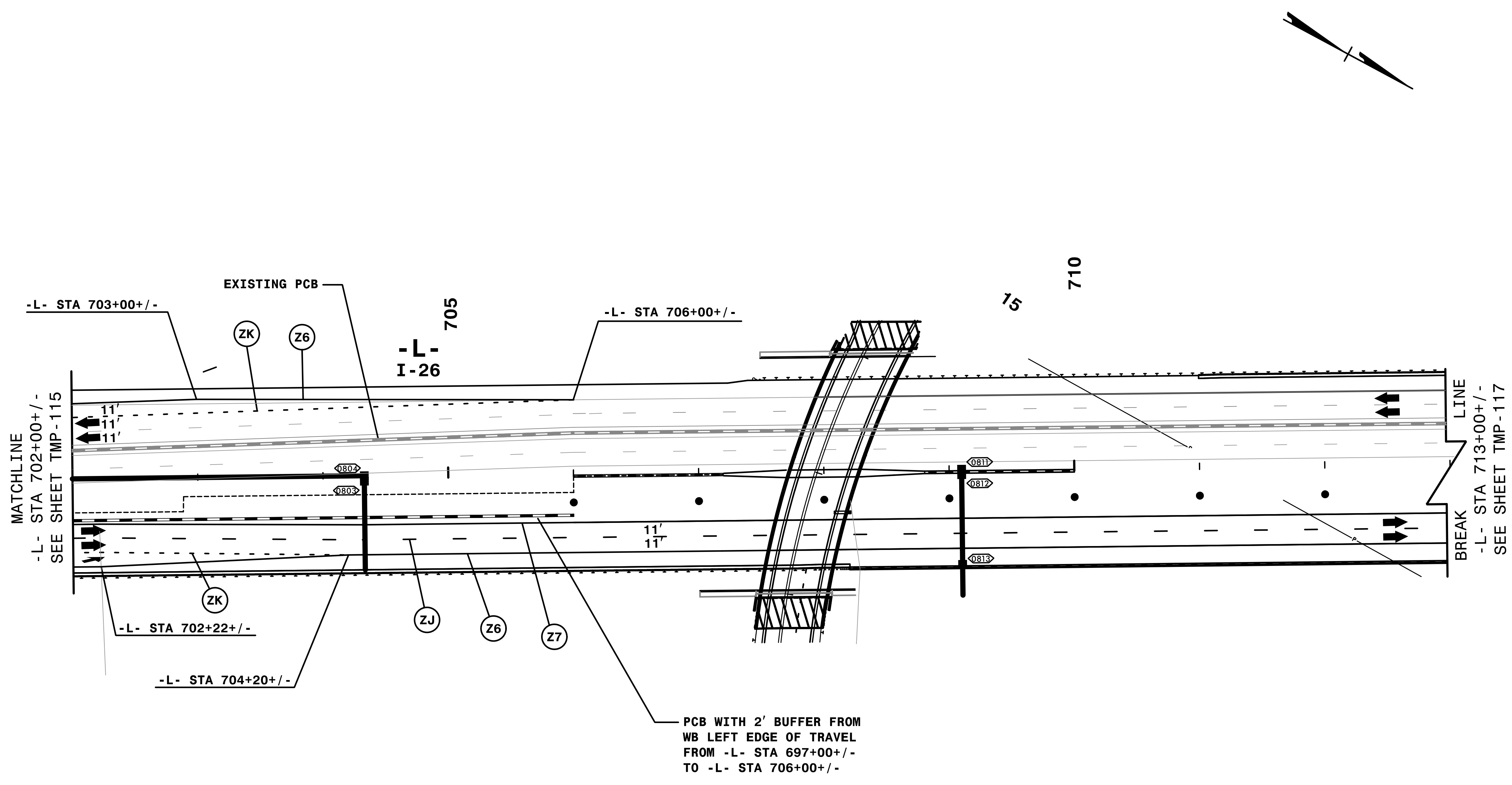

9/3/2019
 ***DATE\$\$\$\$
 ***ICPN4400C-1c-ALP4d6.dgn

HNTB
 HNTB NORTH CAROLINA, P.C.
 343 E. Six Forks Road, Suite 200
 Raleigh, North Carolina 27609
 NC License No: C-1554

APPROVED: *Rhonda B. Early*
 DATE: 9/3/2019

Seal: NORTH CAROLINA PROFESSIONAL ENGINEER RYONDA B. EARLY SEAL 023521

DOCUMENT NOT CONSIDERED FINAL UNLESS ALL SIGNATURES COMPLETED

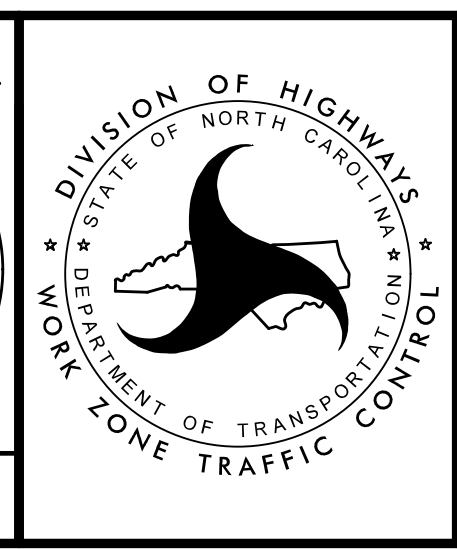

TRANSPORTATION MANAGEMENT PLAN

PHASE IV DETAIL

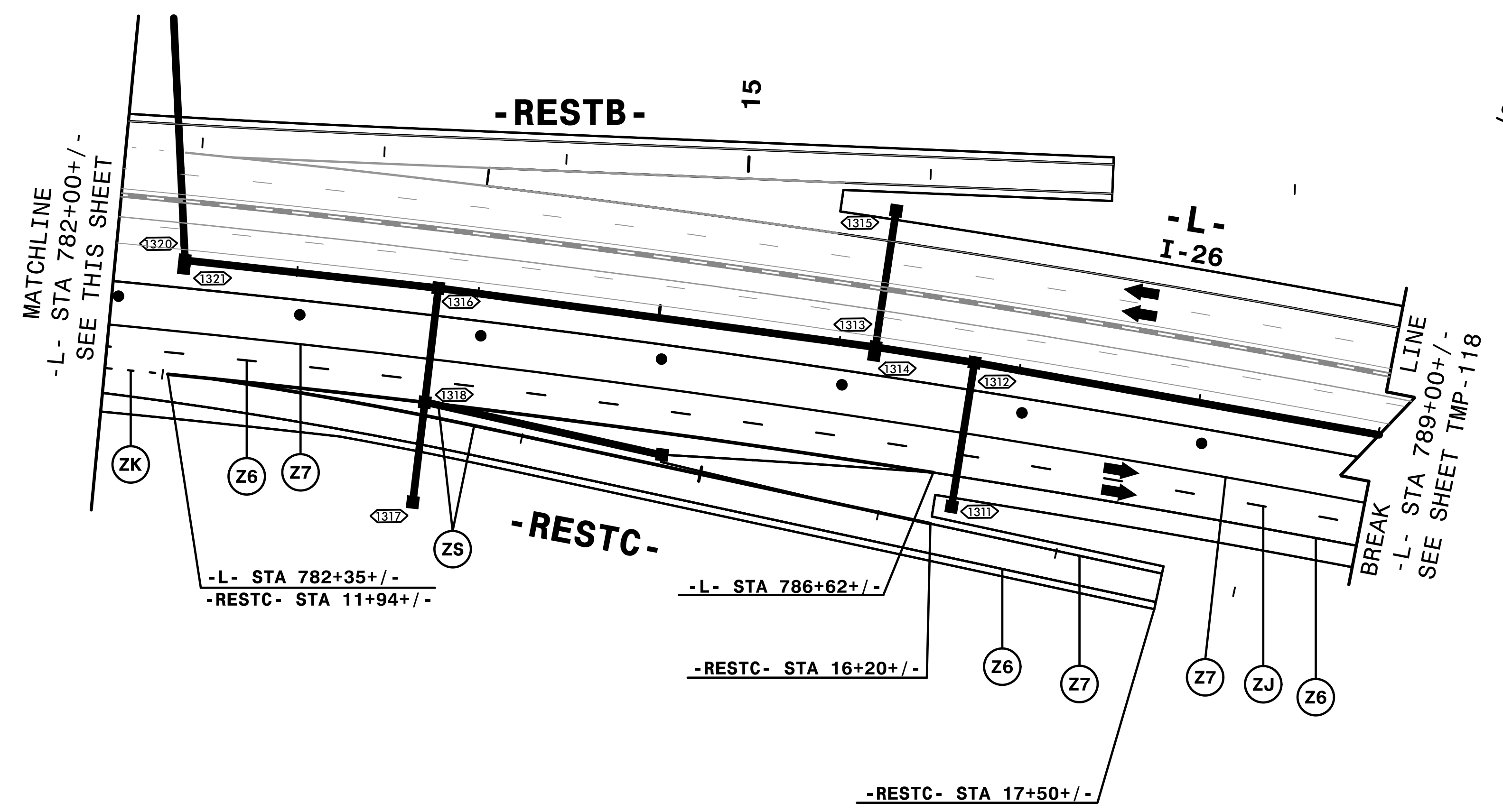
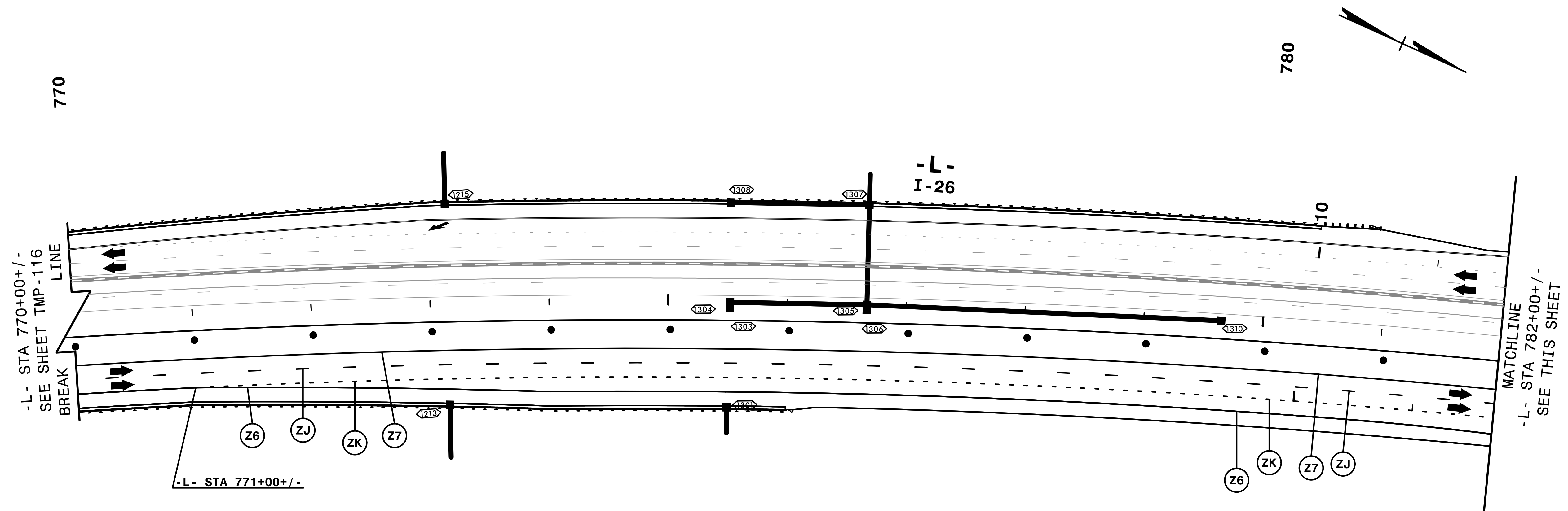

9/3/2019
 I:\CPN\4400C-1c_ALP4d7.dgn
 \$\$\$DATE\$\$\$



DocuSigned by:
 APPROVED: *Rhonda B. Early*
 F3ACAF5AC0BF4BA
 DATE: 9/3/2019

SEAL
 NORTH CAROLINA
 PROFESSIONAL ENGINEER
 023521
 RHONDA B. EARLY

**DOCUMENT NOT CONSIDERED FINAL
 UNLESS ALL SIGNATURES COMPLETED**

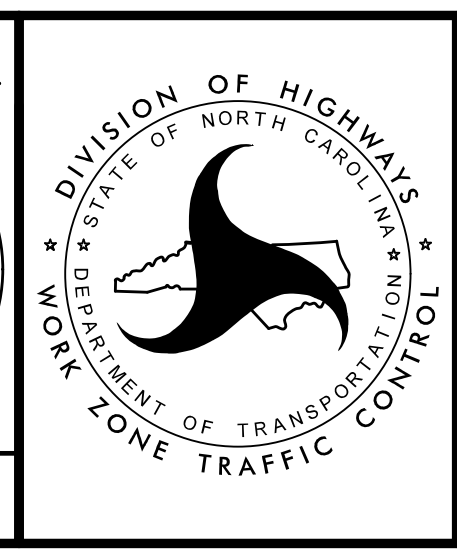

TRANSPORTATION
 MANAGEMENT PLAN

PHASE IV
 DETAIL

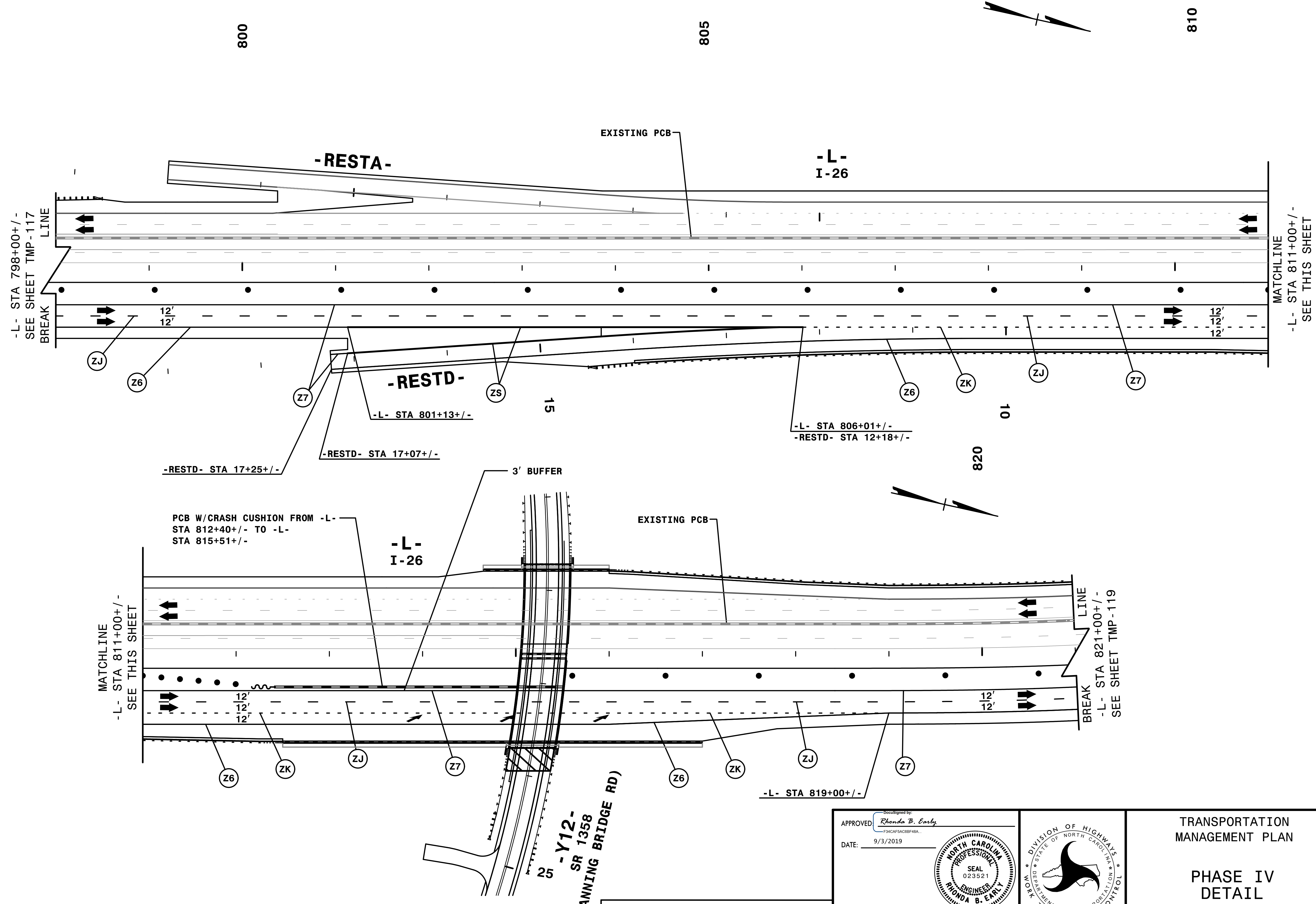

9/3/2019
 I:\CPN\4400C-1c_ALP4d8.dgn
 \$\$\$DATE\$\$\$

HNTB
 HNTB NORTH CAROLINA, P.C.
 343 E. SIX FORKS ROAD, SUITE 200
 RALEIGH, NORTH CAROLINA 27609
 NC LICENSE NO: C-1554

APPROVED: *Rhonda B. Early*
 DATE: 9/3/2019
 NORTH CAROLINA PROFESSIONAL ENGINEER
 SEAL 023521
 RHONDA B. EARLY

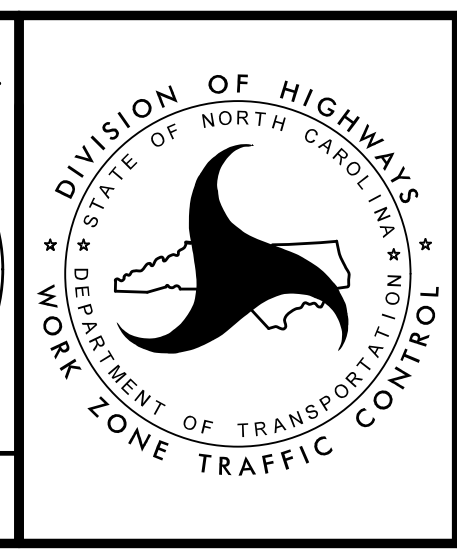

TRANSPORTATION MANAGEMENT PLAN
 PHASE IV DETAIL

DOCUMENT NOT CONSIDERED FINAL
 UNLESS ALL SIGNATURES COMPLETED

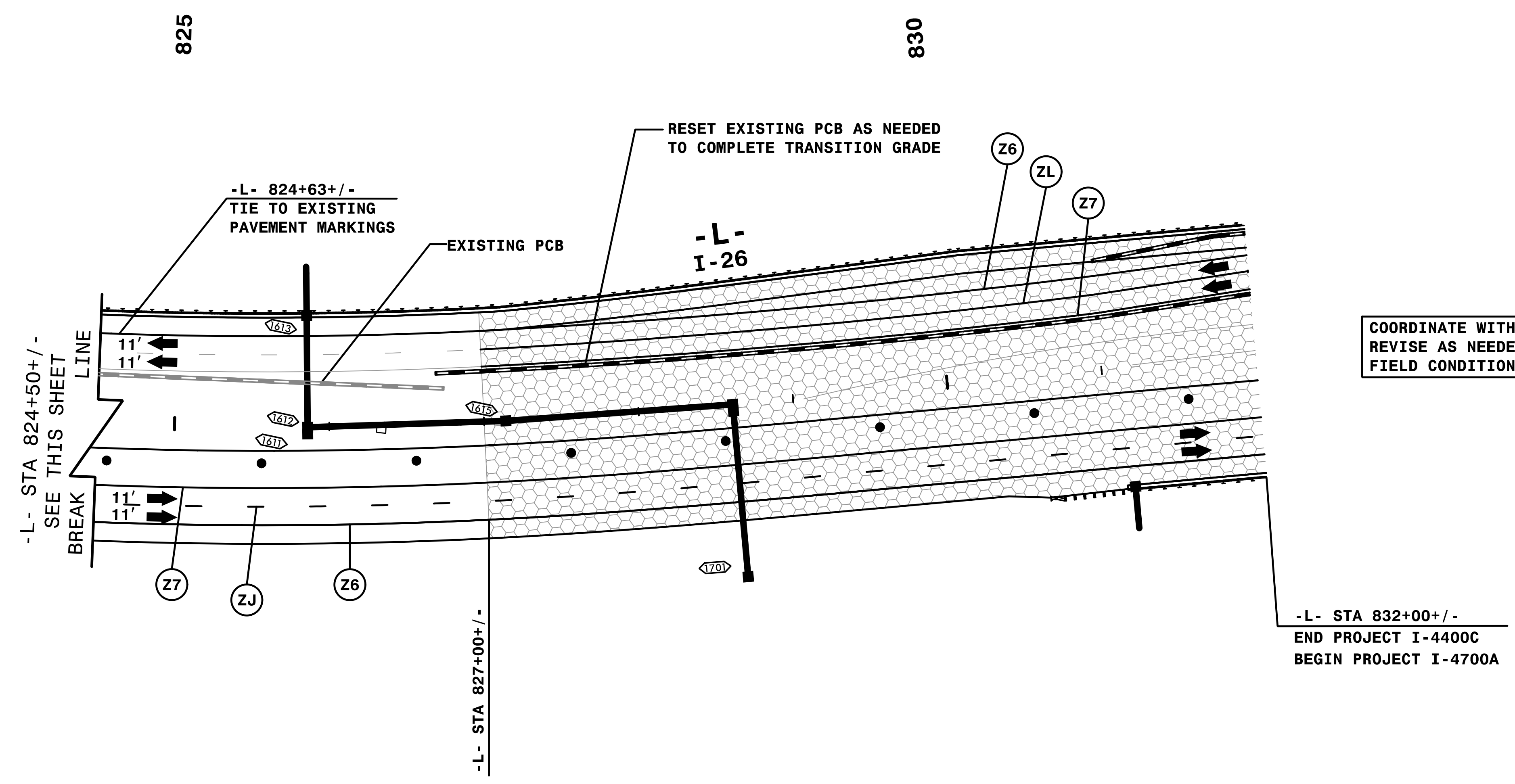
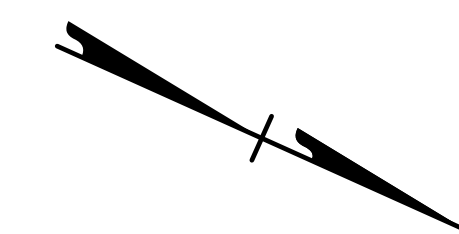

COORDINATE WITH I-4700 AND
REVISE AS NEEDED FOR CURRENT
FIELD CONDITIONS

-L- STA 832+00+/-
END PROJECT I-4400C
BEGIN PROJECT I-4700A

9/3/2019
I:\CPN\4400C-1c_ALP4d9.dgn
DATE

HNTB
HNTB NORTH CAROLINA, P.C.
343 E. SIX FORKS ROAD, SUITE 200
RALEIGH, NORTH CAROLINA 27609
NC LICENSE NO: C-1554

APPROVED: *Rhonda B. Early*
DATE: 9/3/2019
NORTH CAROLINA
PROFESSIONAL
ENGINEER
SEAL
023521
RHONDA B. EARLY

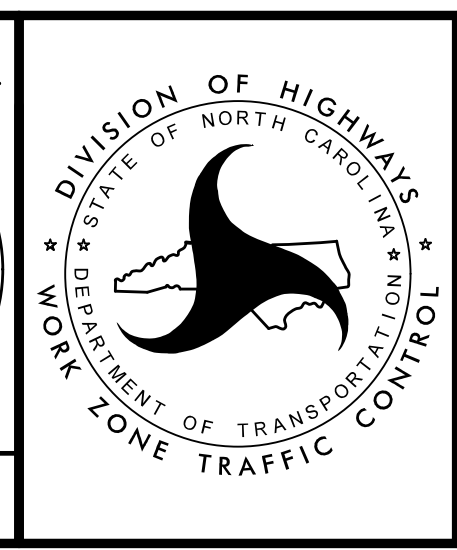

TRANSPORTATION
MANAGEMENT PLAN

PHASE IV
DETAIL

DOCUMENT NOT CONSIDERED FINAL
UNLESS ALL SIGNATURES COMPLETED

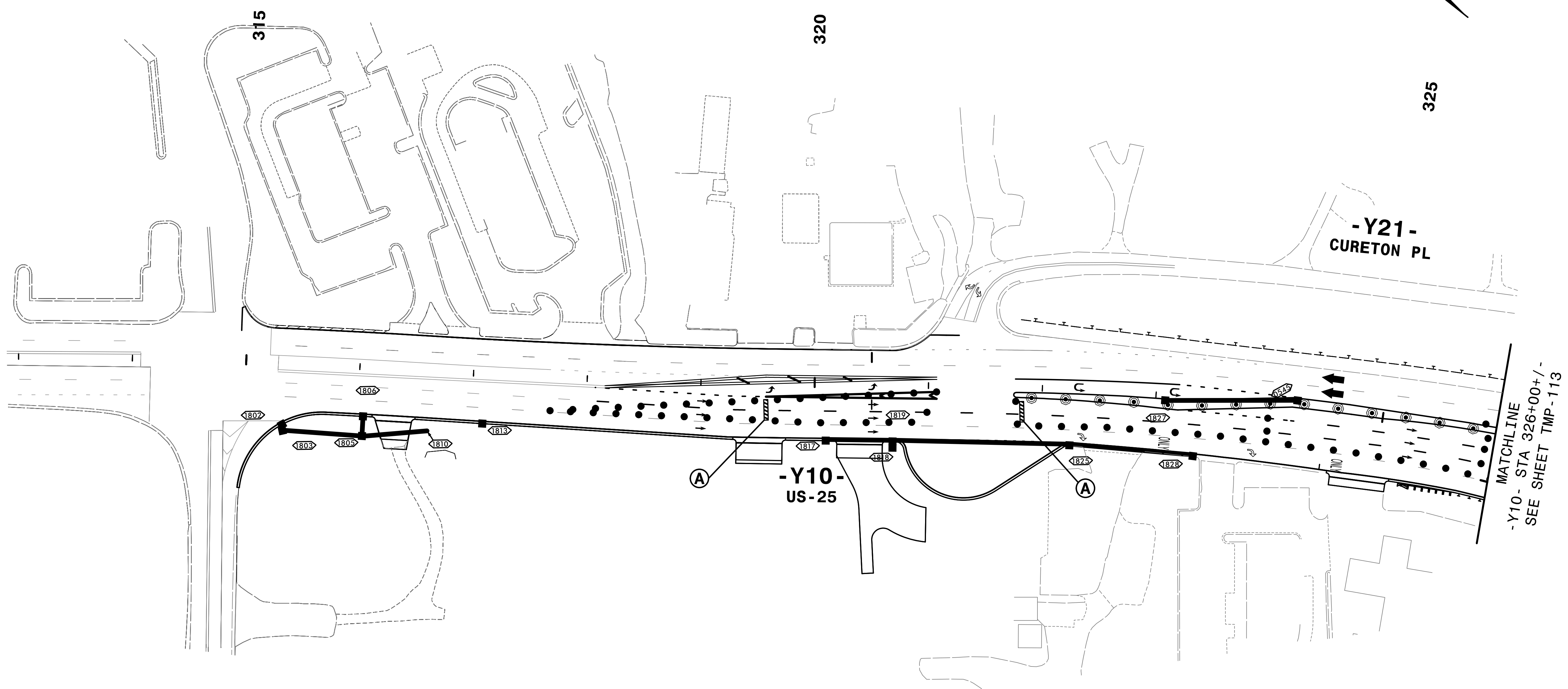
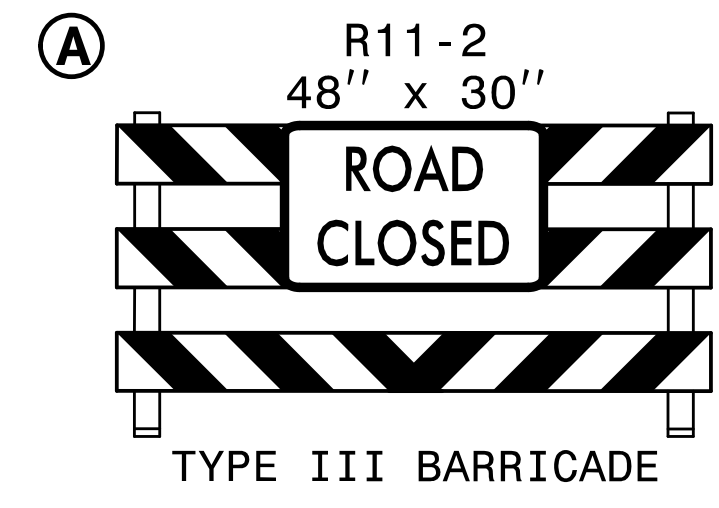

9/3/2019
TCN\4400C-TC-AL.P4d10.dgn
DATE

HNTB HNTB NORTH CAROLINA, P.C.
343 E. Six Forks Road, Suite 200
Raleigh, North Carolina 27609
NC License No: C-1554

DocuSigned by:
Rhonda B. Early
F3ACAF5AC0BF4BA

APPROVED: _____
DATE: 9/3/2019

**DOCUMENT NOT CONSIDERED FINAL
UNLESS ALL SIGNATURES COMPLETED**

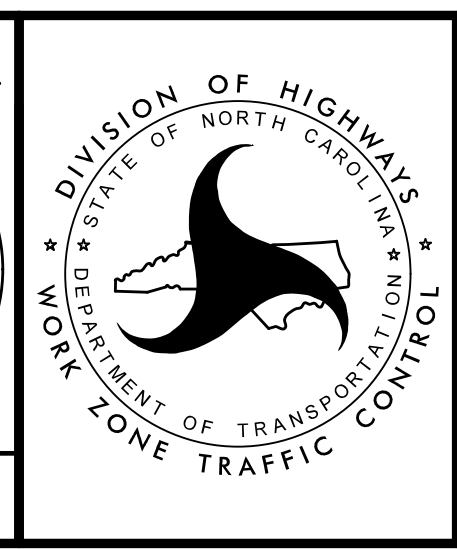

TRANSPORTATION
MANAGEMENT PLAN

PHASE IV
DETAIL

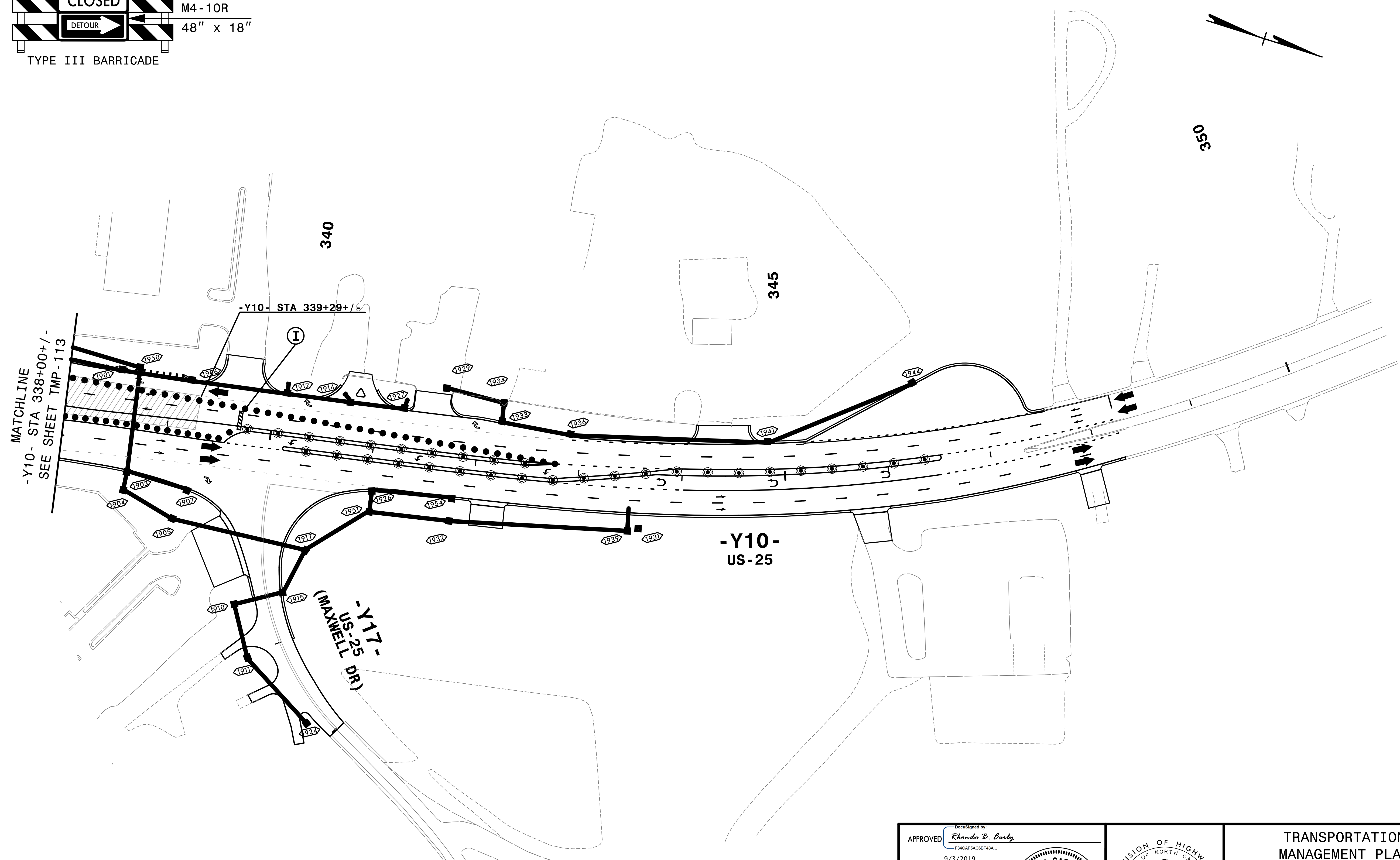
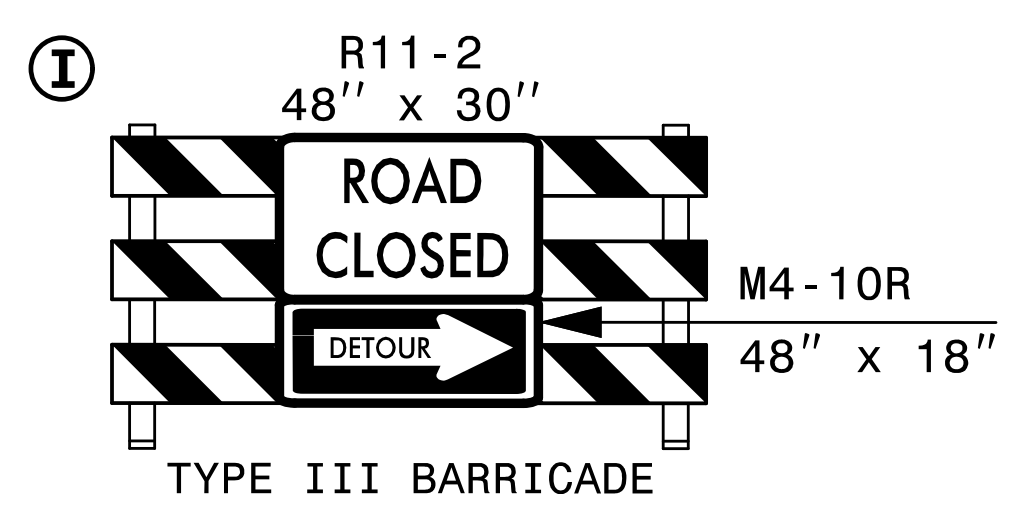

NOTE: ALL LANE WIDTHS ARE 12' UNLESS OTHERWISE SHOWN.

REMOVE CONFLICTING PAVEMENT MARKING.

9/3/2019
 \\CPN\4400C-TC-ALP4dl.dgn
 DATE

HNTB
 HNTB NORTH CAROLINA, P.C.
 343 E. Six Forks Road, Suite 200
 Raleigh, North Carolina 27609
 NC License No: C-1554

APPROVED: *Rhonda B. Early*
F3ACAF5AC0BF4BA

DATE: 9/3/2019

**DOCUMENT NOT CONSIDERED FINAL
 UNLESS ALL SIGNATURES COMPLETED**

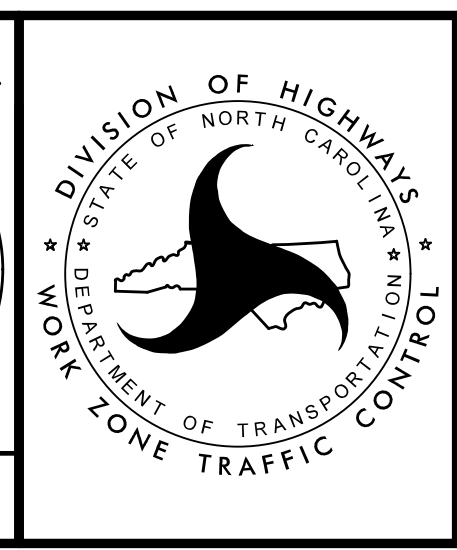

TRANSPORTATION
 MANAGEMENT PLAN

PHASE IV
 DETAIL

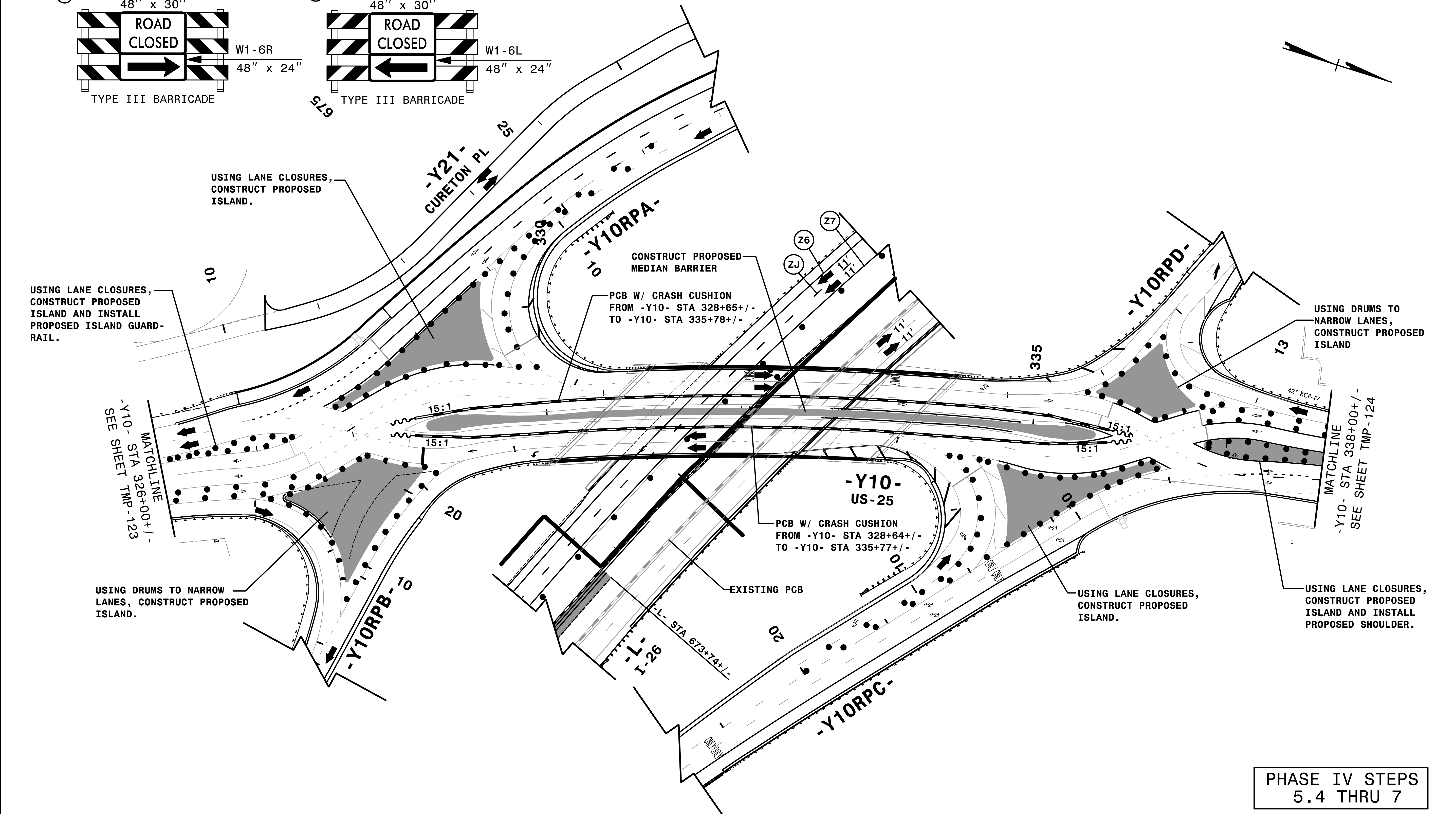
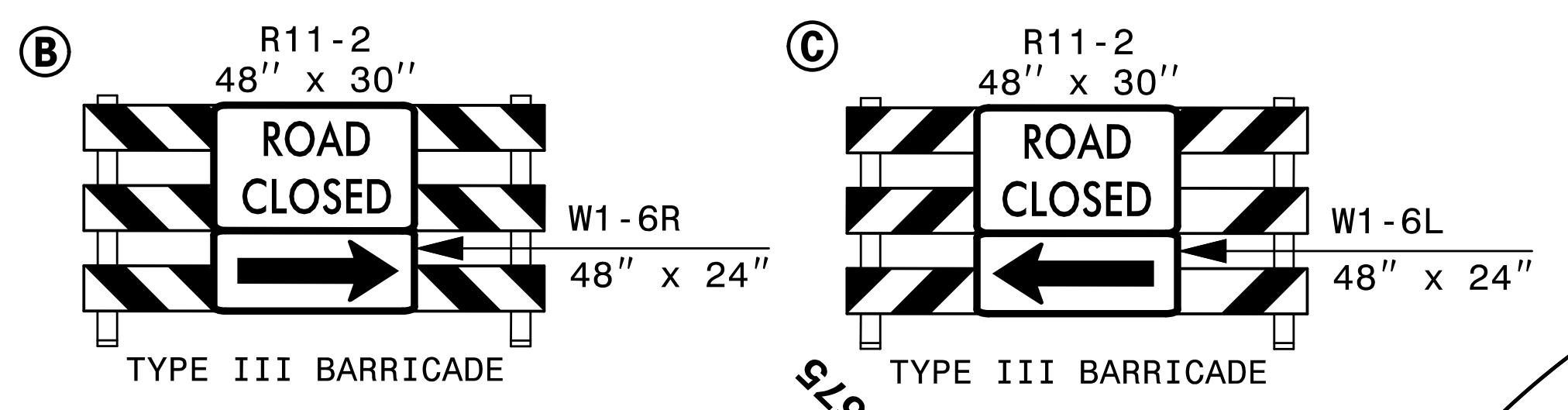

**PHASE IV STEPS
5.4 THRU 7**

9/3/2019
I:\CPN\4400C-1c_AL.P4d12.dgn
DATE

HNTB
HNTB NORTH CAROLINA, P.C.
343 E. Six Forks Road, Suite 200
Raleigh, North Carolina 27609
NC License No: C-1554

APPROVED: *Rhonda B. Early*
F3ACAF8AC0BF4BA
DATE: 9/3/2019
PROFESSIONAL ENGINEER
NORTH CAROLINA
SEAL
023521
RHONDA B. EARLY

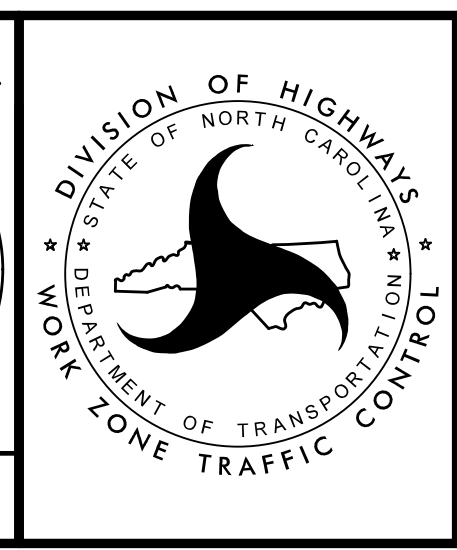

TRANSPORTATION
MANAGEMENT PLAN

**PHASE IV
DETAIL**

**DOCUMENT NOT CONSIDERED FINAL
UNLESS ALL SIGNATURES COMPLETED**

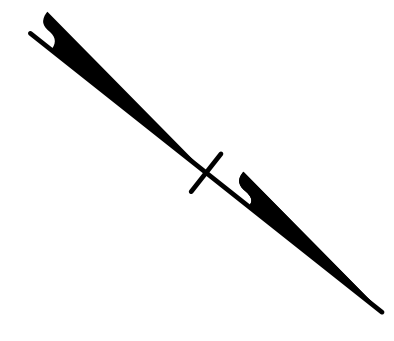
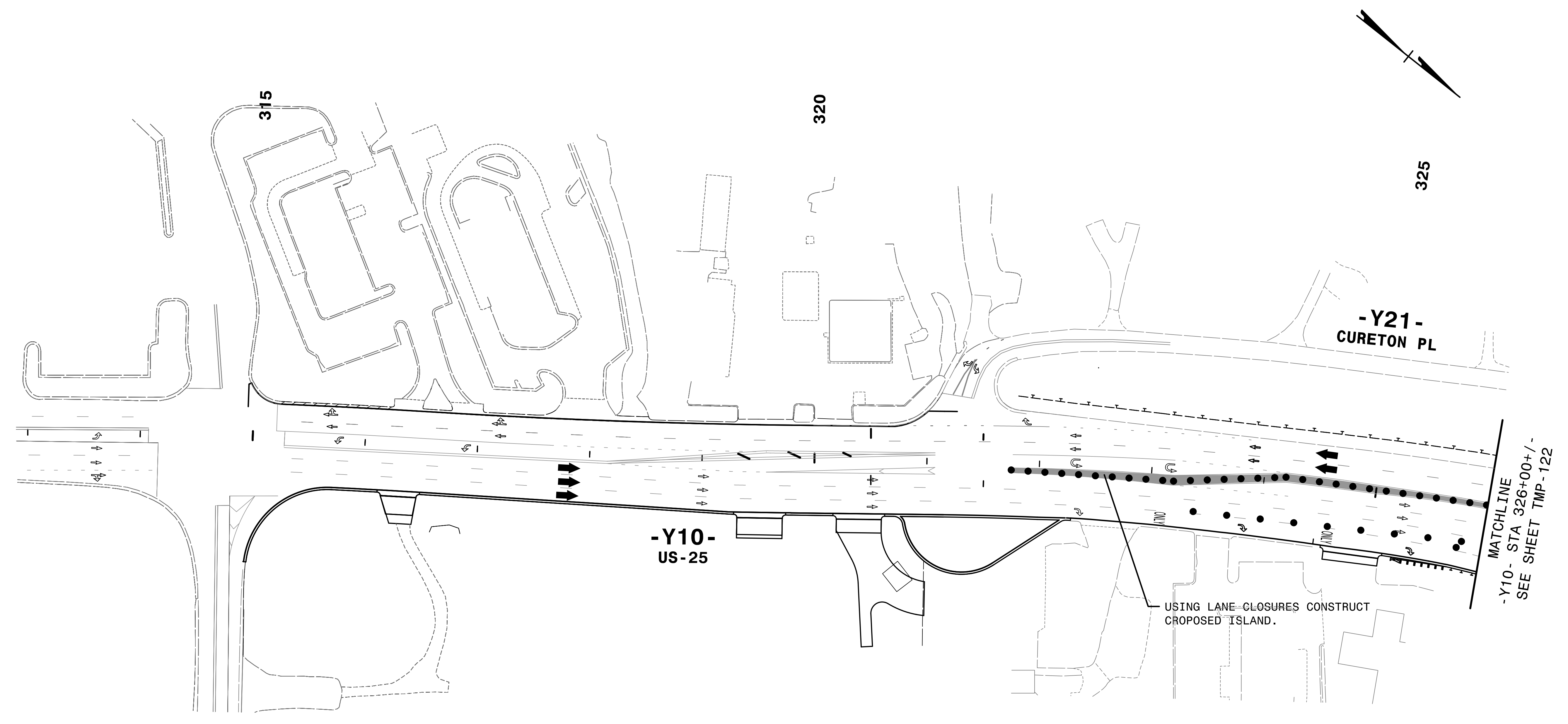

STEPS 5.4 THRU 7

REMOVE CONFLICTING PAVEMENT MARKING.

9/3/2019
 ***ICPN4400C-1c-ALP4d13.dgn
 \$\$\$DATE\$\$\$

HNTB
 HNTB NORTH CAROLINA, P.C.
 343 E. Six Forks Road, Suite 200
 Raleigh, North Carolina 27609
 NC License No: C-1554

APPROVED: *Rhonda B. Early*
DocuSigned by:
 Rhonda B. Early
 F3ACAF5AC0BF4BA.
 DATE: 9/3/2019

PROFESSIONAL SEAL
 NORTH CAROLINA
 023521
 ENGINEER
 RHONDA B. EARLY

**DOCUMENT NOT CONSIDERED FINAL
 UNLESS ALL SIGNATURES COMPLETED**



TRANSPORTATION
 MANAGEMENT PLAN

PHASE IV
 DETAIL

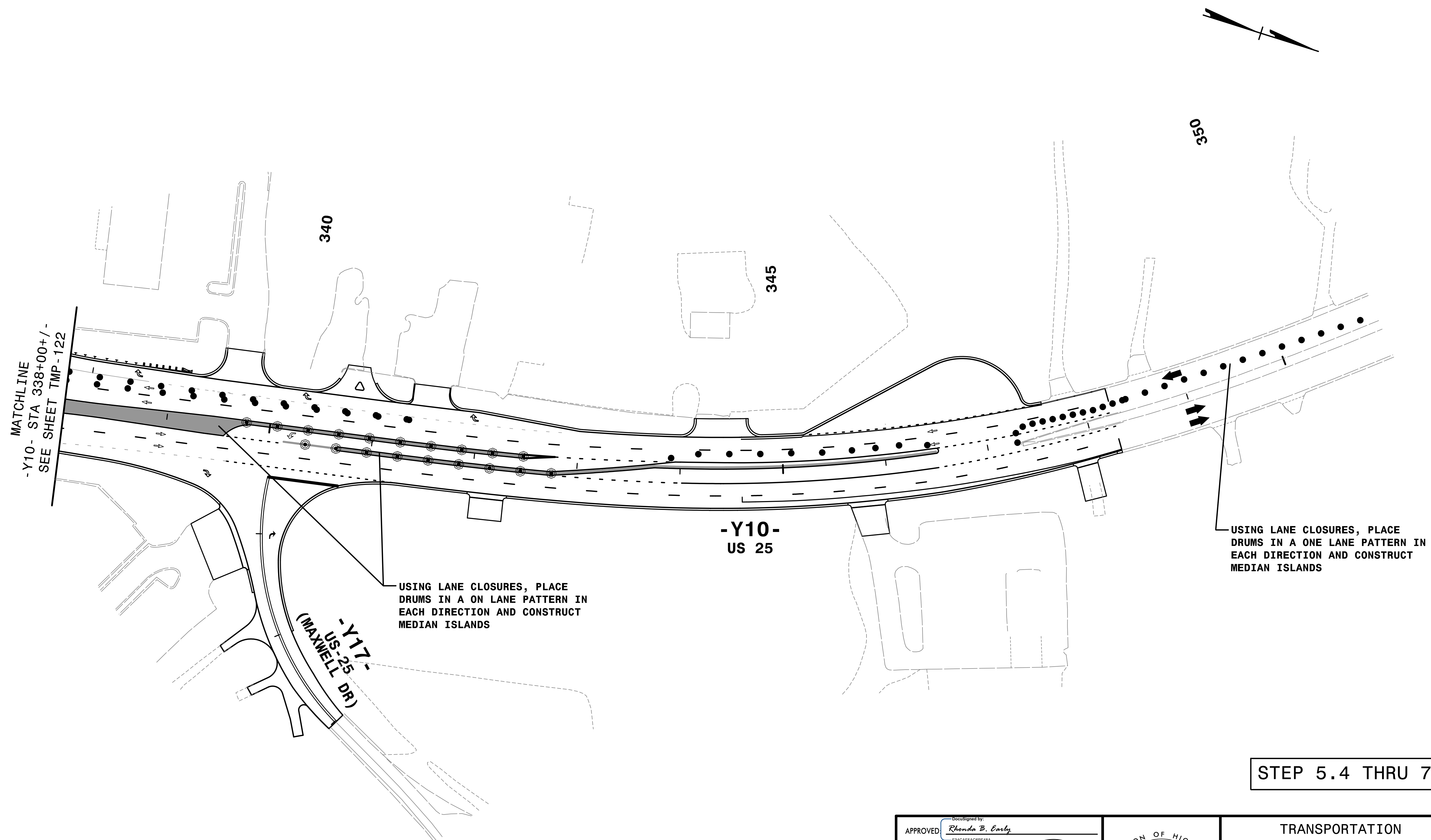

STEP 5.4 THRU 7

9/3/2019
TCN\4400C-TC-ALP4d14.dgn
DATE

REMOVE CONFLICTING PAVEMENT MARKING.

10

HNTB
 HNTB NORTH CAROLINA, P.C.
 343 E. SIX FORKS ROAD, SUITE 200
 RALEIGH, NORTH CAROLINA 27609
 NC LICENSE NO: C-1554

APPROVED: *Rhonda B. Early*
F3ACAF5AC0BF4BA
 DATE: 9/3/2019

NORTH CAROLINA
 PROFESSIONAL
 SEAL
 023521
 ENGINEER
 RHONDA B. EARLY

**DOCUMENT NOT CONSIDERED FINAL
 UNLESS ALL SIGNATURES COMPLETED**



TRANSPORTATION
 MANAGEMENT PLAN

PHASE IV
 DETAIL