

**This electronic collection of documents is provided
for the convenience of the user
and is Not a Certified Document –**

**The documents contained herein were originally issued
and sealed by the individuals whose names and license
numbers appear on each page, on the dates appearing
with their signature on that page.**

**This file or an individual page
shall not be considered a certified document.**

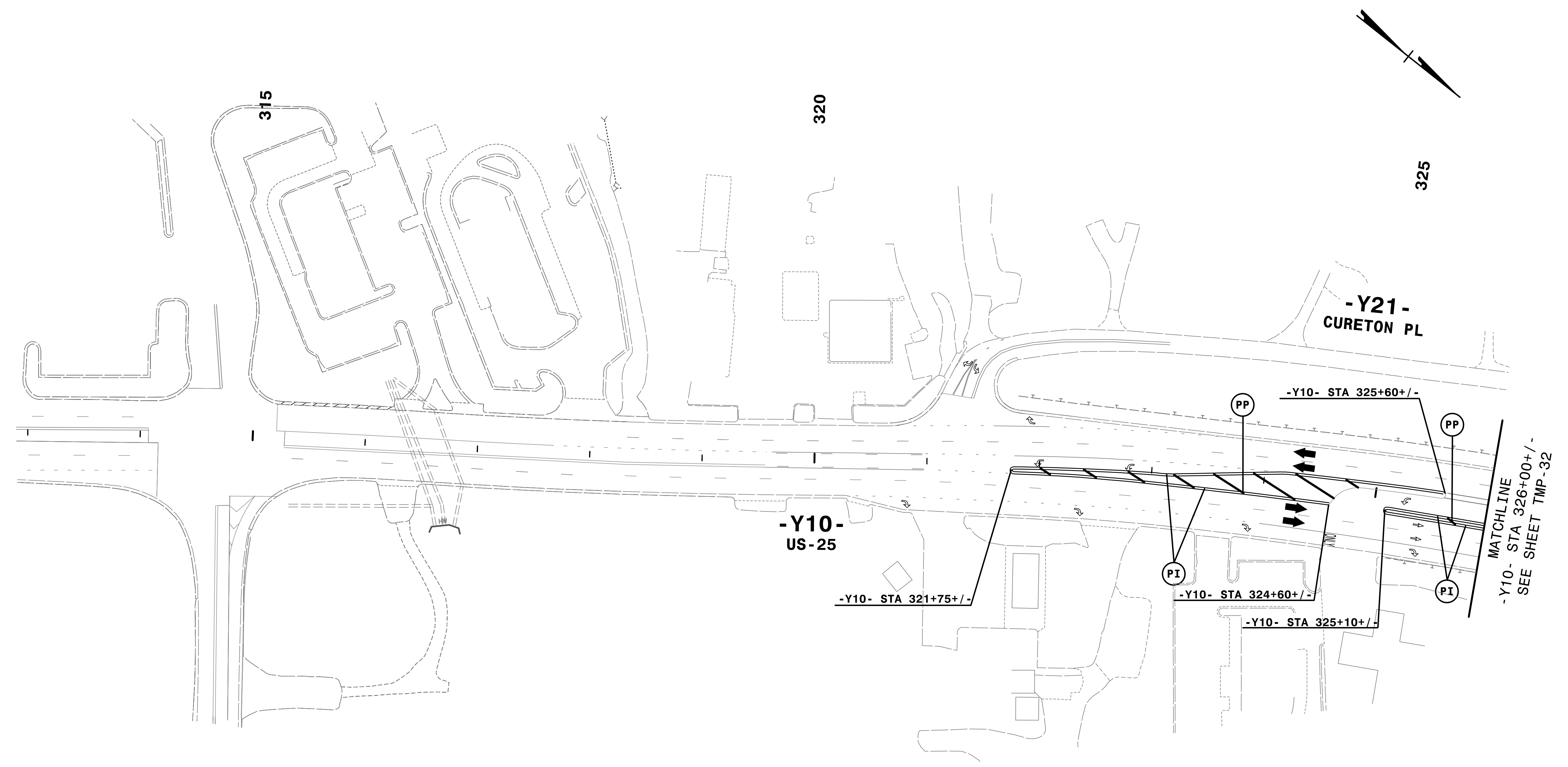

3:19:28 PM
\\TCN\4400C-TC-ALP2d45.dgn
9/3/2019

HNTB
 HNTB NORTH CAROLINA, P.C.
 343 E. SIX FORKS ROAD, SUITE 200
 RALEIGH, NORTH CAROLINA 27609
 NC LICENSE NO: C-1554

DocuSigned by:
 APPROVED: *Rhonda B. Early*
 F34CAFAC6BFB4A
 DATE: 9/3/2019

PROFESSIONAL ENGINEER SEAL
 NORTH CAROLINA
 023521
 RHONDA B. EARLY

**DOCUMENT NOT CONSIDERED FINAL
 UNLESS ALL SIGNATURES COMPLETED**



TRANSPORTATION
 MANAGEMENT PLAN

PHASE II
 DETAIL

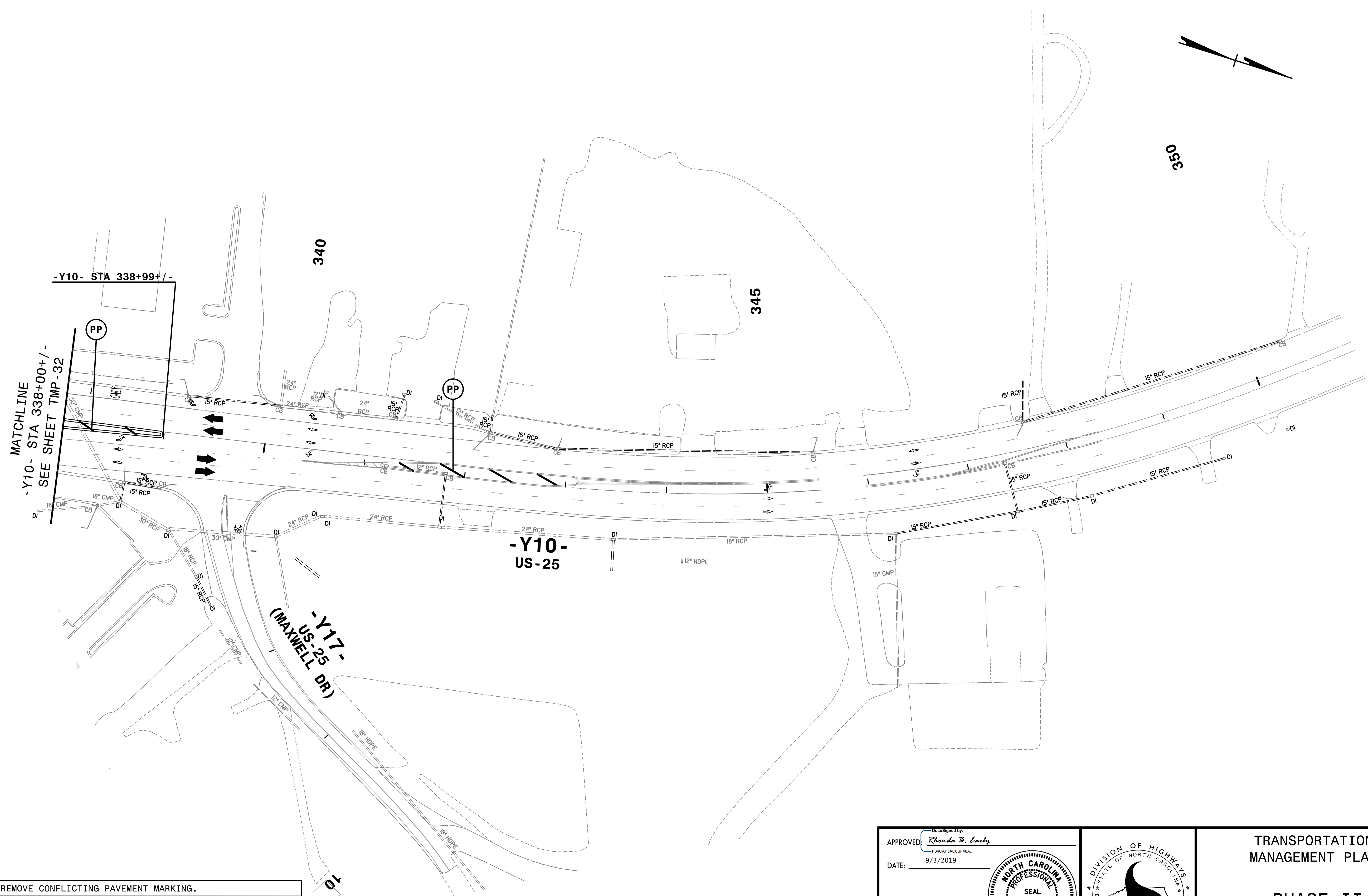

MATCHLINE
-Y10- STA 338+00 +/-
SEE SHEET TMP-32

-Y10- STA 338+99 +/-

-Y10-
US-25

-Y17-
US-25
(MAXWELL DR)

REMOVE CONFLICTING PAVEMENT MARKING.

3:19:38 PM
\\TC\N\4400C-TC_ALP2d46.dgn
9/3/2019

HNTB HNTB NORTH CAROLINA, P.C.
343 E. Six Forks Road, Suite 200
Raleigh, North Carolina 27609
NC License No: C-1554

DocuSigned by:
APPROVED: *Rhonda B. Early*
F34CAFAC6BFB4A
DATE: 9/3/2019

**DOCUMENT NOT CONSIDERED FINAL
UNLESS ALL SIGNATURES COMPLETED**

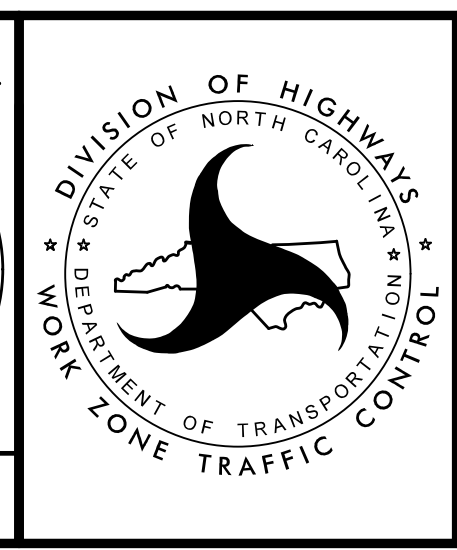

TRANSPORTATION
MANAGEMENT PLAN

PHASE II
DETAIL

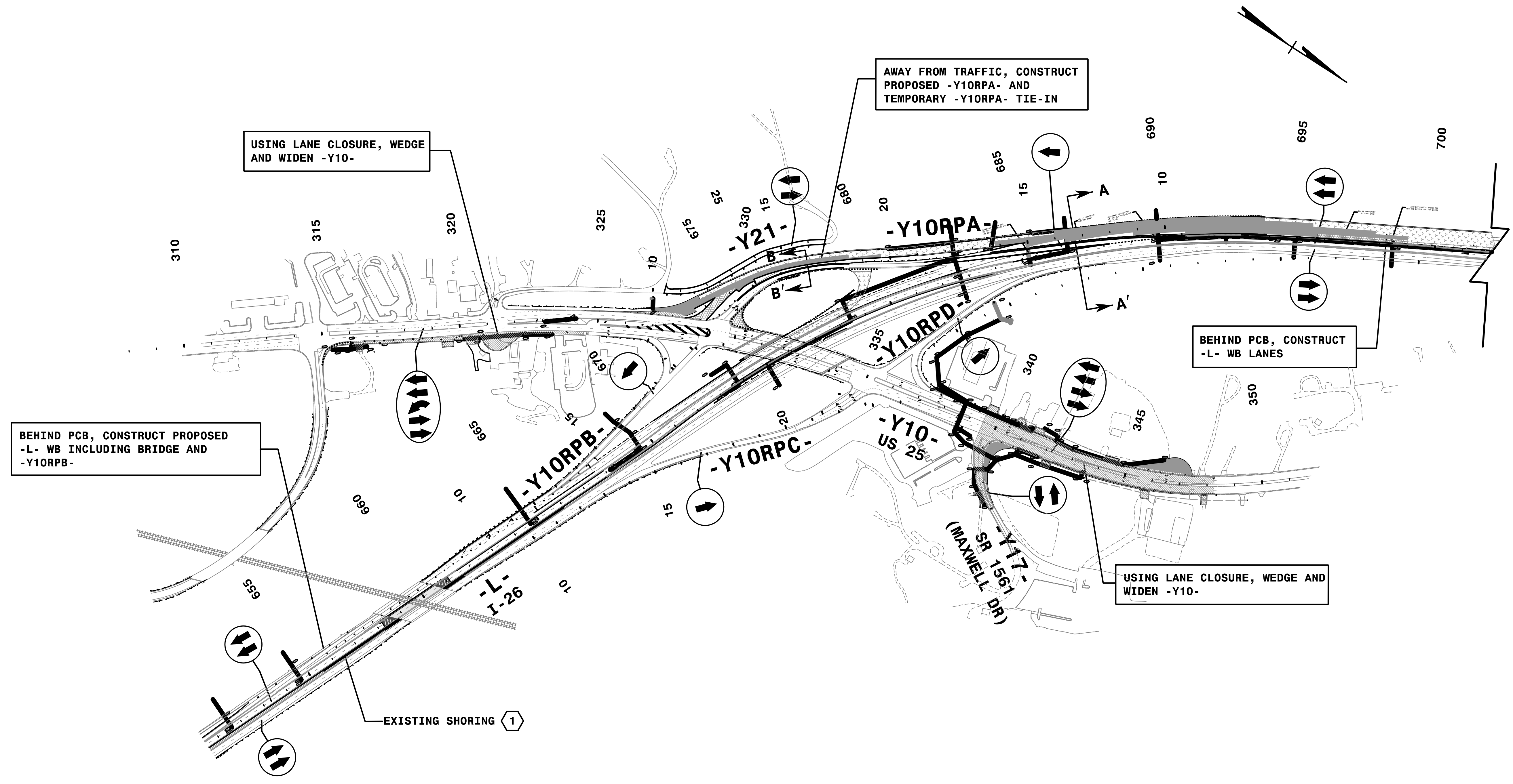

REFER TO SHEET TMP-2A FOR SHORING DATA.

REFER TO SHEET TMP-49 FOR CUT SECTION(S).

3:20:15 PM
 \\TCN\4400C-1c_PHASE_2a_0v.dgn
 9/3/2019

HNTB
 HNTB NORTH CAROLINA, P.C.
 343 E. Six Forks Road, Suite 200
 Raleigh, North Carolina 27609
 NC License No: C-1554

APPROVED: *Rhonda B. Early*
 DATE: 9/3/2019

PROFESSIONAL ENGINEER SEAL
 NORTH CAROLINA
 023521
 RHONDA B. EARLY

DOCUMENT NOT CONSIDERED FINAL UNLESS ALL SIGNATURES COMPLETED

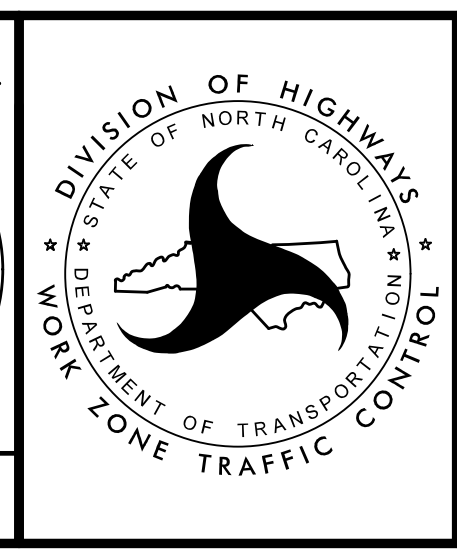

TRANSPORTATION MANAGEMENT PLAN

PHASE IIA OVERVIEW

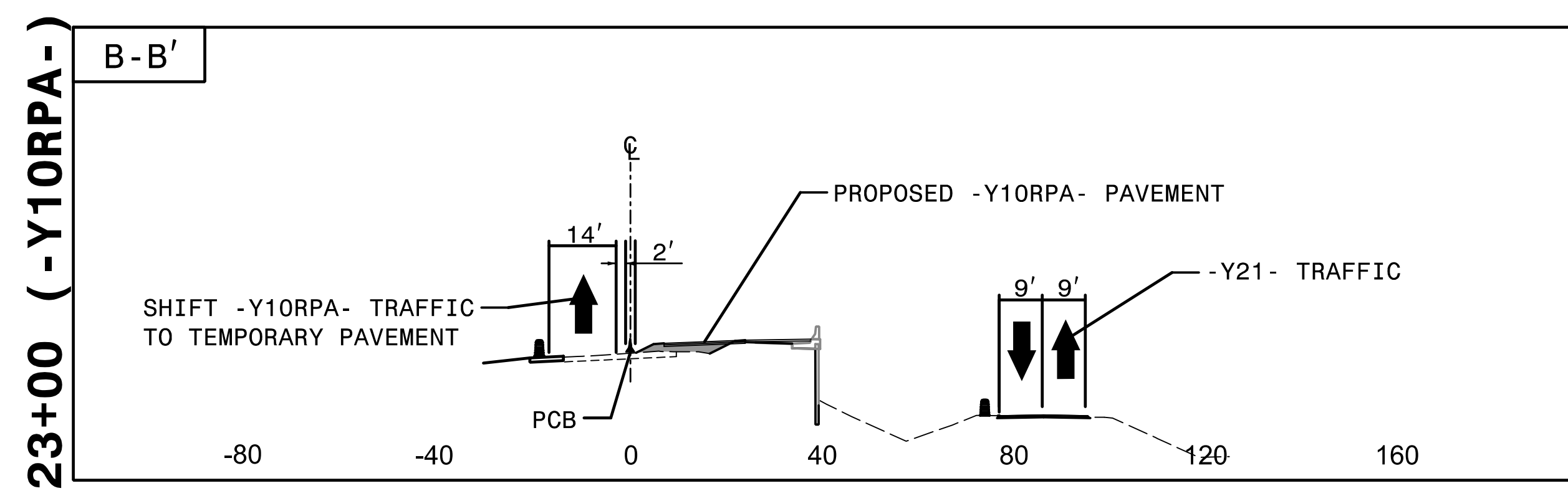
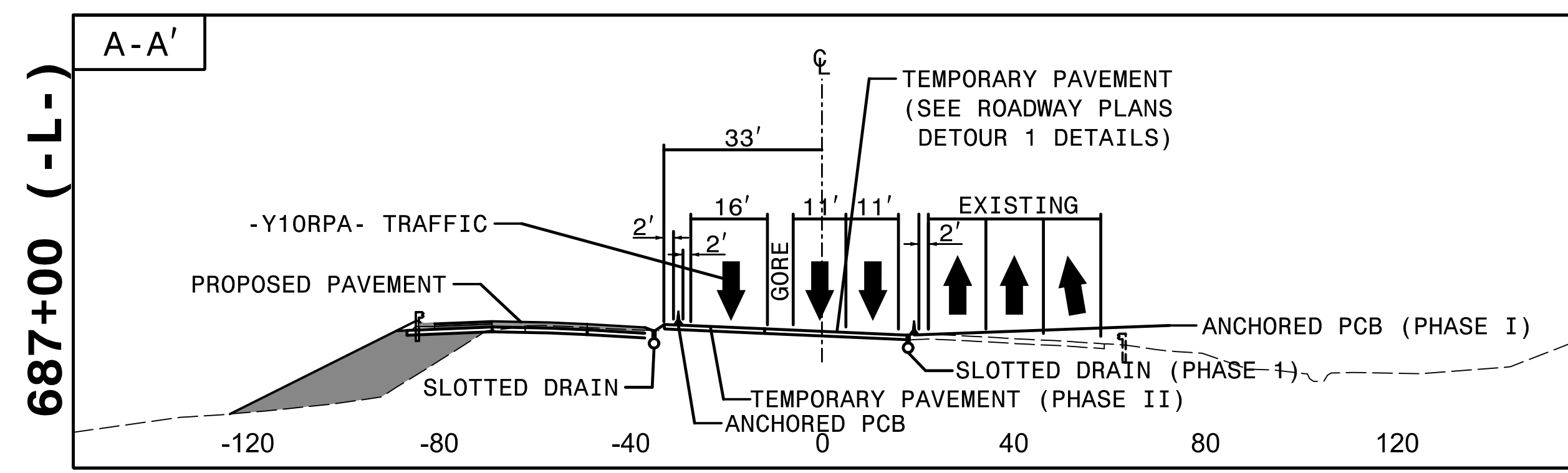

3:20:58 PM
3:\TCN\4400C_fc_P2 CUTS.dgn
9/3/2019

HNTB HNTB NORTH CAROLINA, P.C.
343 E. Six Forks Road, Suite 200
Raleigh, North Carolina 27609
NC License No: C-1554

APPROVED: *Rhonda B. Early*
F34CAFAC08BF8A
DATE: 9/3/2019

PROFESSIONAL SEAL
NORTH CAROLINA
ENGINEER
RHONDA B. EARLY
023521

**DOCUMENT NOT CONSIDERED FINAL
UNLESS ALL SIGNATURES COMPLETED**

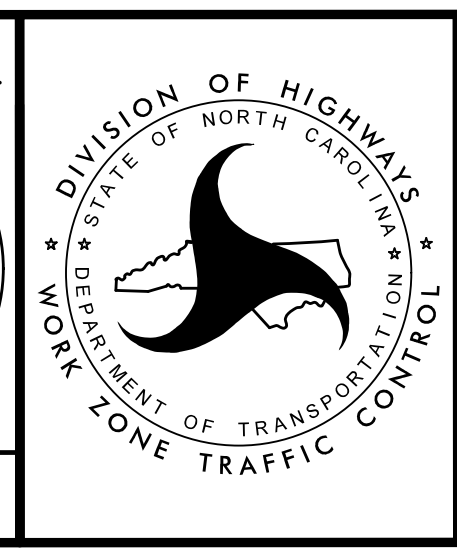

TRANSPORTATION
MANAGEMENT PLAN

**PHASE IIA
CUT SECTIONS**

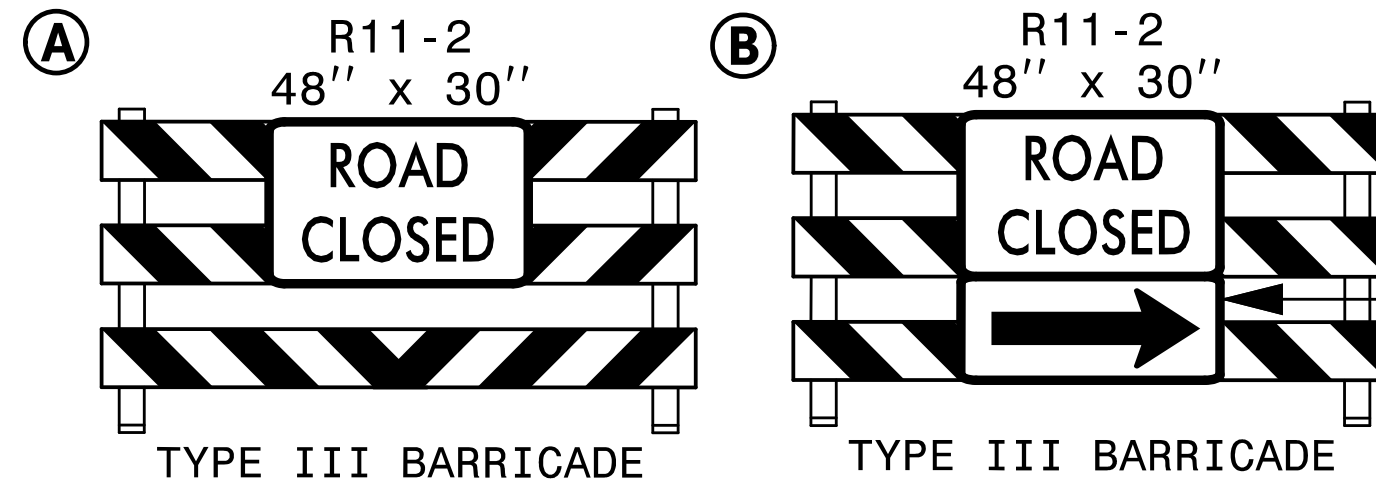

TYPE III BARRICADE
TYPE III BARRICADE

PCB W/ TEMPORARY ANCHOR
FROM -Y10RPA- STA 20+90+/-
TO -Y10RPA- STA 25+86+/-
TIE TO EXISTING

W1-6R
48'' x 24''

USING LANE CLOSURES AS
NEEDED, CONSTRUCT
TEMPORARY ACCESS RAMP
-DETOUR 5-
REFER TO I-4400C ROADWAY
SHEET 2B-21

USING LANE CLOSURES
CONSTRUCT WIDENING ON
-Y10- AND -Y10RPA SPUR_RT-

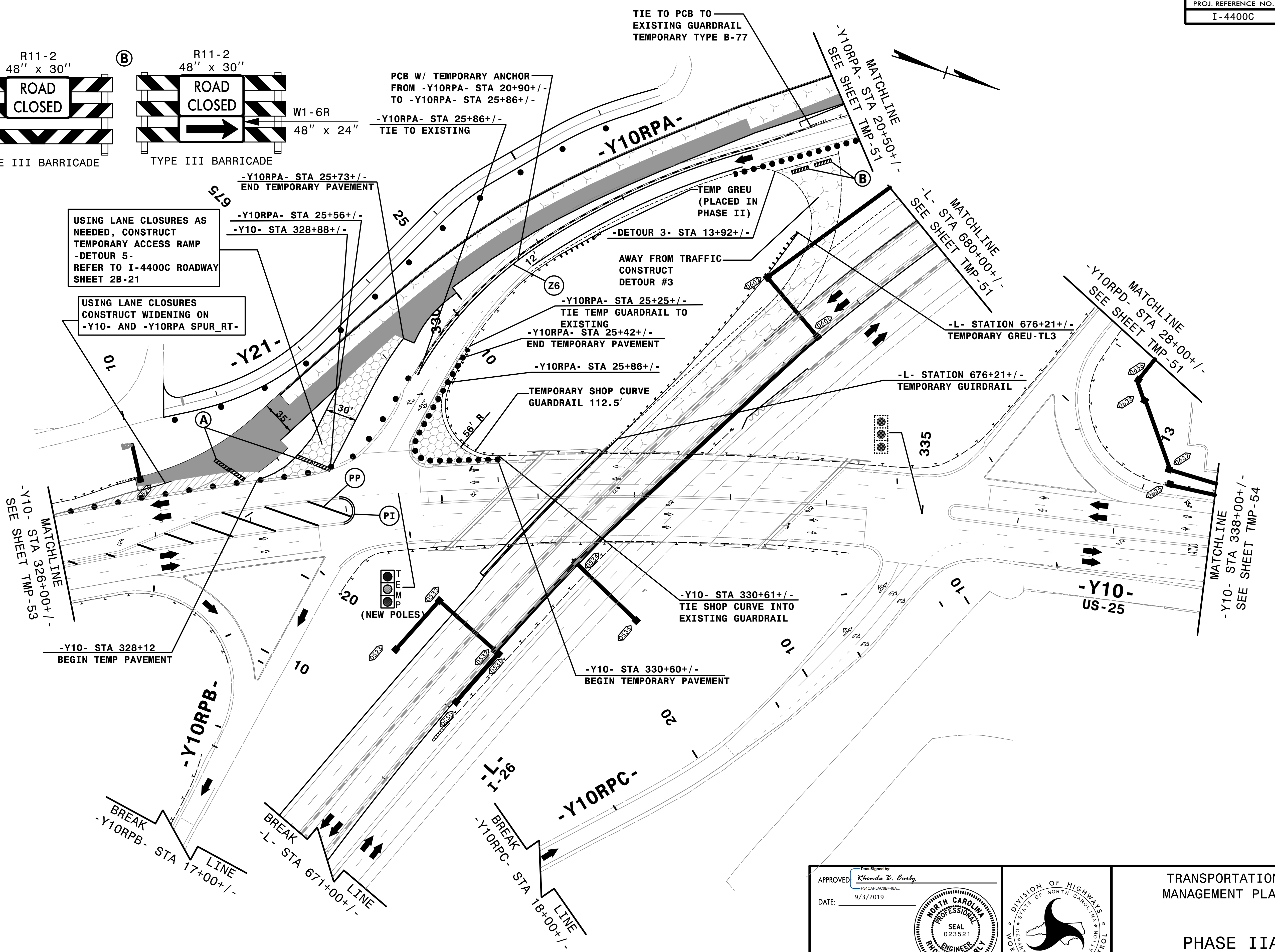

MATCHLINE
-Y10- STA 326+00+/-
SEE SHEET TMP-53

-Y10- STA 328+12
BEGIN TEMP PAVEMENT

BREAK
-Y10RPB- STA 17+00+/-
LINE

BREAK
-L- STA 671+00+/-
LINE

BREAK
-Y10RPC- STA 18+00+/-
LINE

-Y10- STA 330+60+/-
BEGIN TEMPORARY PAVEMENT

-Y10- STA 330+61+/-
TIE SHOP CURVE INTO
EXISTING GUARDRAIL

-Y10-
US-25

MATCHLINE
-Y10- STA 338+00+/-
SEE SHEET TMP-54

3:24:27 PM
C:\TCP\4400C-TC-ALP2ad3.dgn
9/3/2019

REMOVE CONFLICTING PAVEMENT MARKING.

HNTB HNTB NORTH CAROLINA, P.C.
343 E. Six Forks Road, Suite 200
Raleigh, North Carolina 27609
NC License No: C-1554

APPROVED: *Rhonda B. Early*
DATE: 9/3/2019

DIVISION OF HIGHWAYS
STATE OF NORTH CAROLINA
DEPARTMENT OF TRANSPORTATION
WORK ZONE TRAFFIC CONTROL

TRANSPORTATION
MANAGEMENT PLAN
PHASE IIA
DETAIL

DOCUMENT NOT CONSIDERED FINAL
UNLESS ALL SIGNATURES COMPLETED

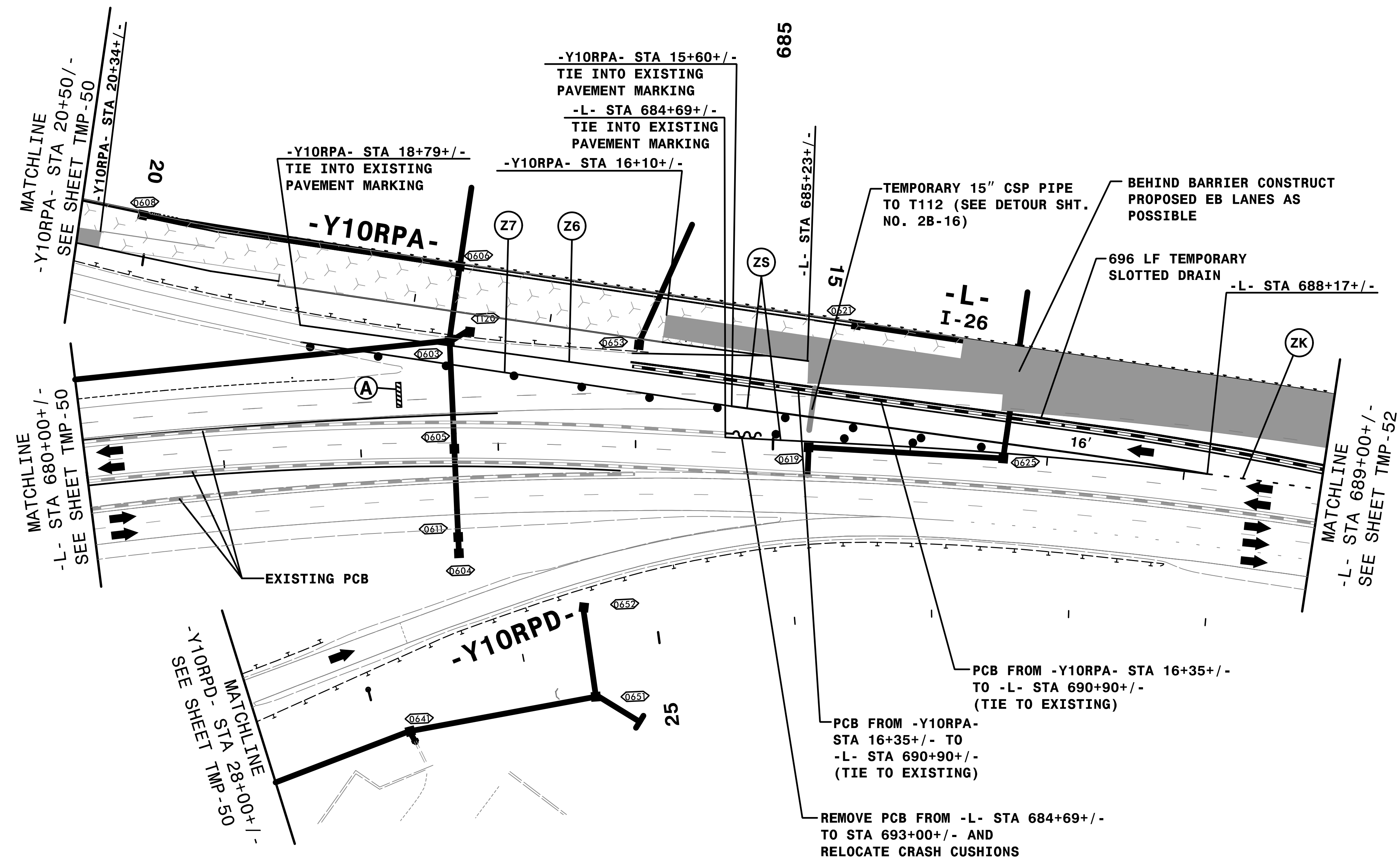
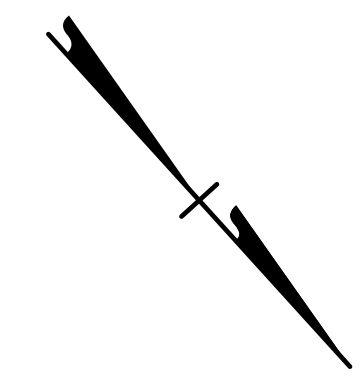
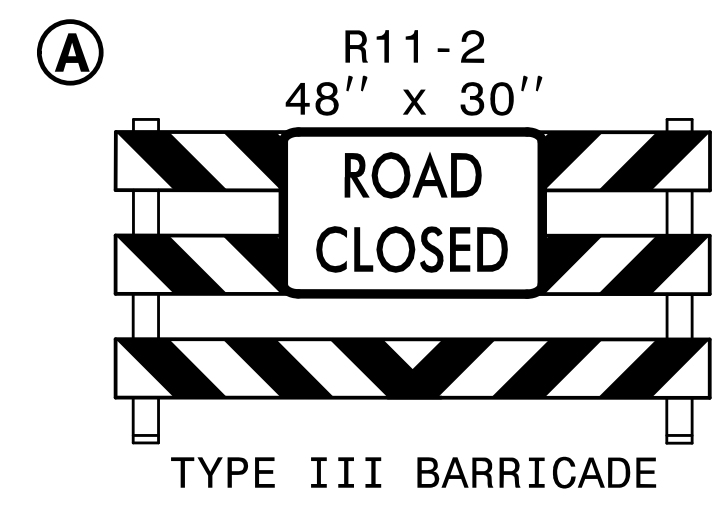

REMOVE CONFLICTING PAVEMENT MARKING.

3:24:40 PM
 \\TCN\4400C-TC-ALP2ad4.dgn
 9/3/2019

HNTB
 HNTB NORTH CAROLINA, P.C.
 343 E. Six Forks Road, Suite 200
 Raleigh, North Carolina 27609
 NC License No: C-1554

DocuSigned by:
 APPROVED: *Rhonda B. Early*
 F34CAFAC6BFB4A
 DATE: 9/3/2019

**DOCUMENT NOT CONSIDERED FINAL
 UNLESS ALL SIGNATURES COMPLETED**

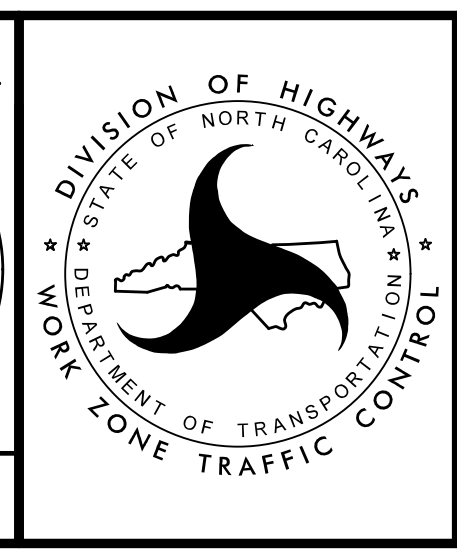

TRANSPORTATION
 MANAGEMENT PLAN

PHASE IIA
 DETAIL

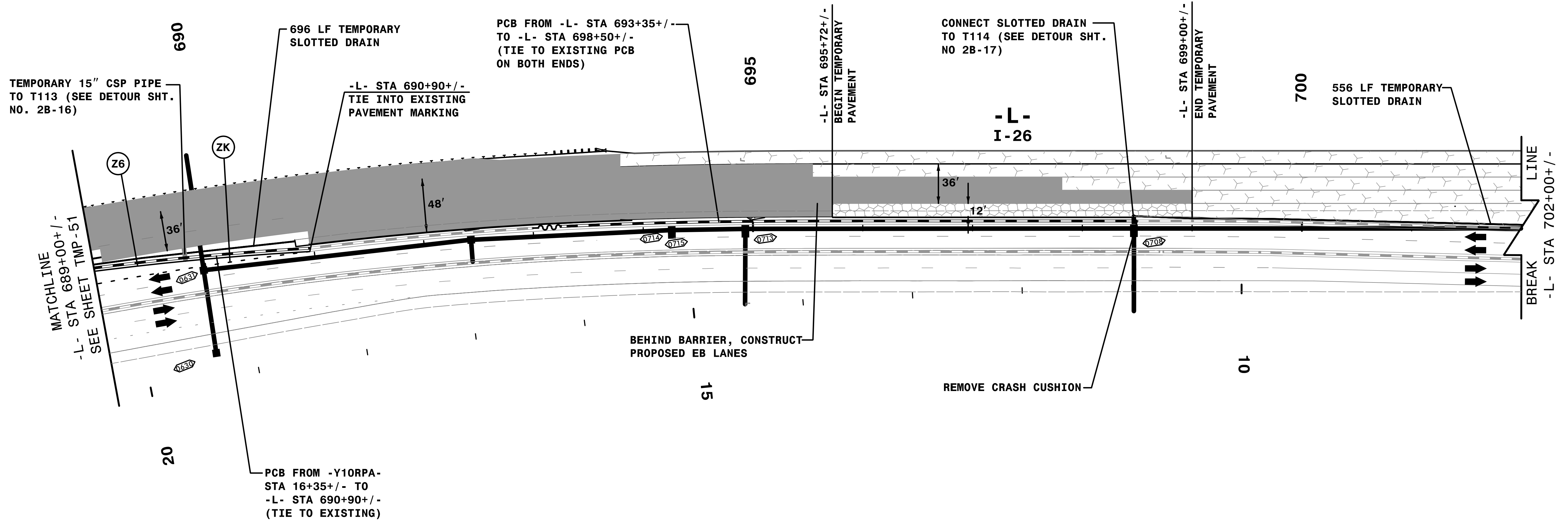
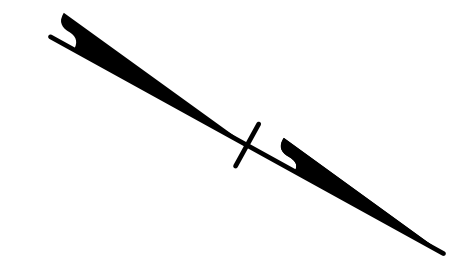

3:24:53 PM
 \\TCN\4400C-TC_ALP2ad5.dgn
 9/3/2019

REMOVE CONFLICTING PAVEMENT MARKING.

HNTB
 HNTB NORTH CAROLINA, P.C.
 343 E. Six Forks Road, Suite 200
 Raleigh, North Carolina 27609
 NC License No: C-1554

APPROVED: *Rhonda B. Early*
DocuSigned by:
 F34CAFAC6BFB4A
 DATE: 9/3/2019

SEAL
 NORTH CAROLINA
 PROFESSIONAL
 ENGINEER
 RHONDA B. EARLY
 023521

**DOCUMENT NOT CONSIDERED FINAL
 UNLESS ALL SIGNATURES COMPLETED**

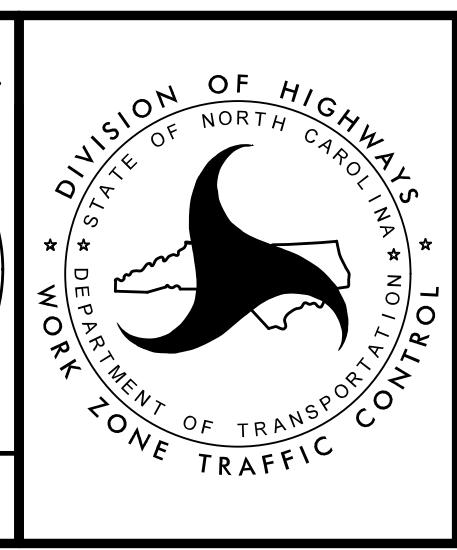

TRANSPORTATION
 MANAGEMENT PLAN

PHASE IIA
 DETAIL

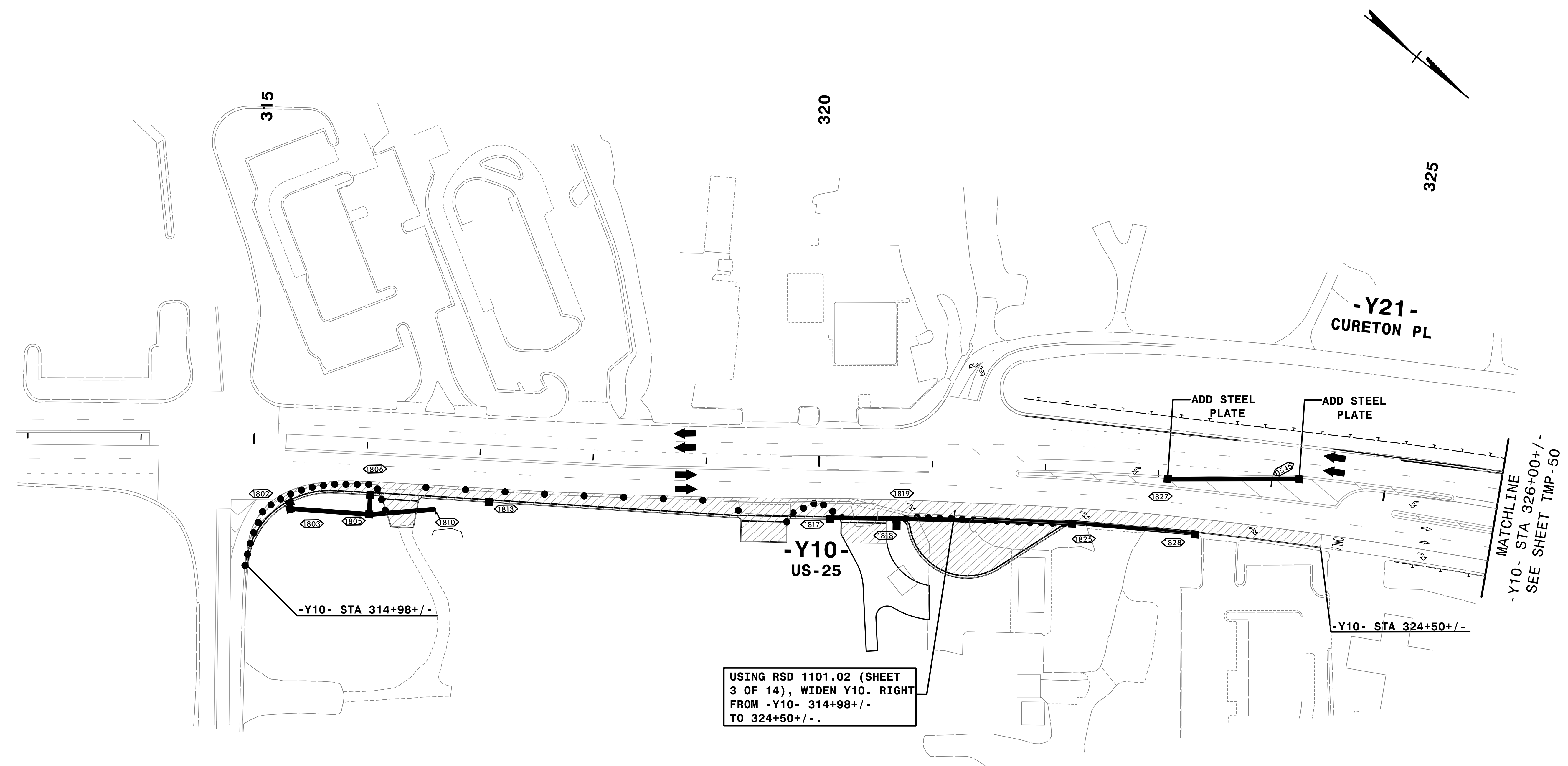

USING RSD 1101.02 (SHEET 3 OF 14), WIDEN Y10. RIGHT FROM -Y10- 314+98+/- TO 324+50+/-.

3:22:06 PM
 \\TCN\4400C-TC_ALP2Ad45.dgn
 9/3/2019

HNTB
 HNTB NORTH CAROLINA, P.C.
 343 E. Six Forks Road, Suite 200
 Raleigh, North Carolina 27609
 NC License No: C-1554

DocuSigned by:
 APPROVED: *Rhonda B. Early*
 F34CAFAC6BFB4A
 DATE: 9/3/2019

DOCUMENT NOT CONSIDERED FINAL UNLESS ALL SIGNATURES COMPLETED

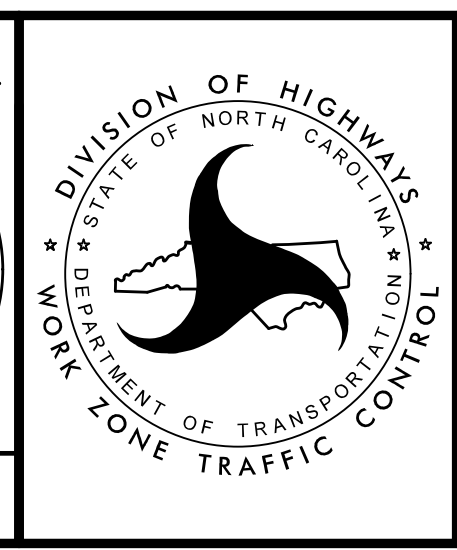

TRANSPORTATION
 MANAGEMENT PLAN

PHASE IIA
 DETAIL

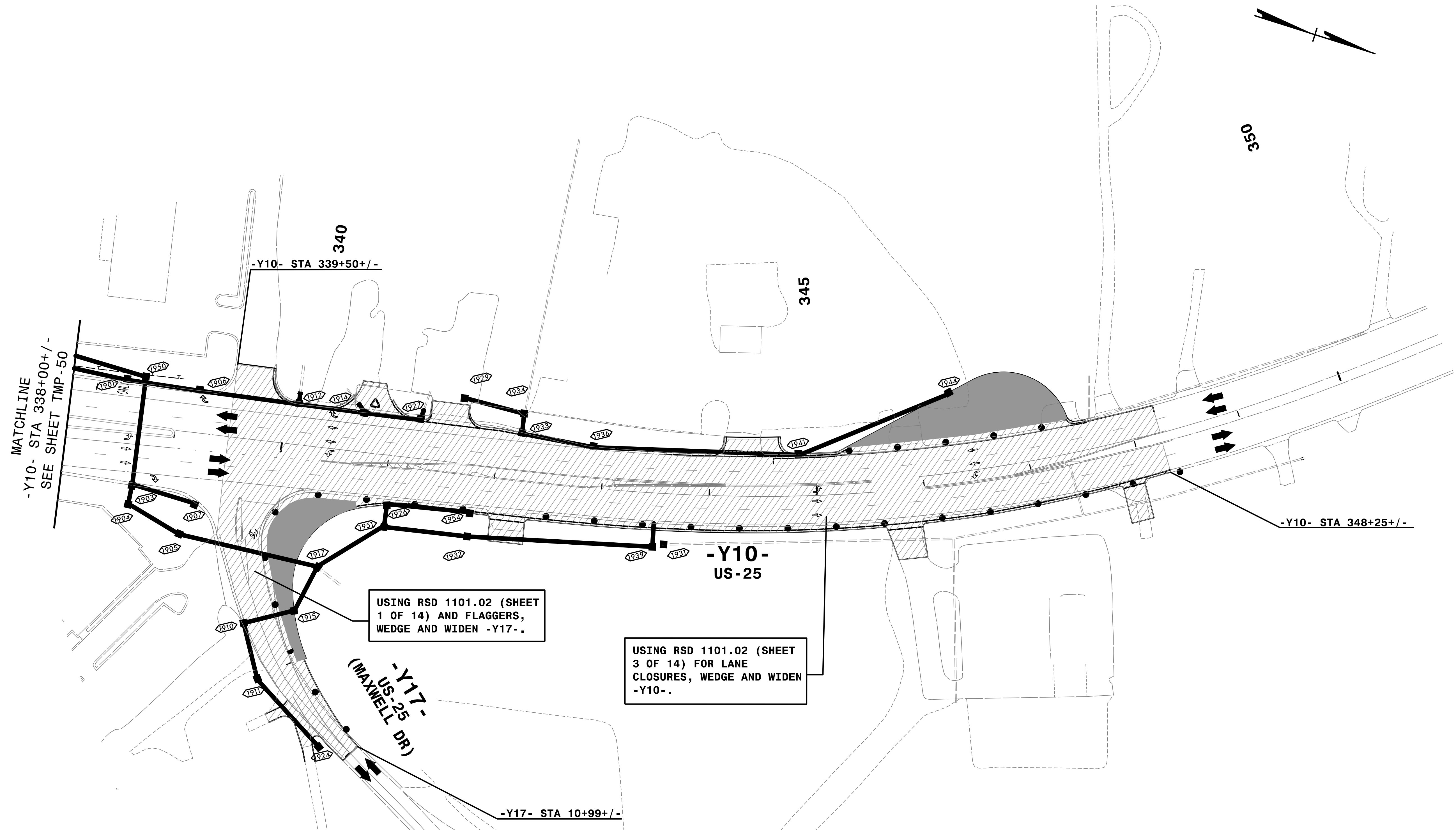

MATCHLINE
-Y10- STA 338+00+/-
SEE SHEET TMP-50

-Y10- STA 339+50+/-

-Y10- STA 348+25+/-

-Y10-
US-25

USING RSD 1101.02 (SHEET
1 OF 14) AND FLAGGERS,
WEDGE AND WIDEN -Y17-.

USING RSD 1101.02 (SHEET
3 OF 14) FOR LANE
CLOSURES, WEDGE AND WIDEN
-Y10-.

-Y17-
US-25
(MAXWELL DR)

-Y17- STA 10+99+/-

REMOVE CONFLICTING PAVEMENT MARKING.

3:22:19 PM
C:\CP\4400C-TC_ALP2Ad46.dgn
9/3/2019

HNTB
HNTB NORTH CAROLINA, P.C.
343 E. Six Forks Road, Suite 200
Raleigh, North Carolina 27609
NC License No: C-1554

APPROVED: *Rhonda B. Early*
DATE: 9/3/2019

DocuSigned by:
Rhonda B. Early
F34CAFAC6BFB4A

PROFESSIONAL ENGINEER
NORTH CAROLINA
SEAL
023521
RHONDA B. EARLY

**DOCUMENT NOT CONSIDERED FINAL
UNLESS ALL SIGNATURES COMPLETED**

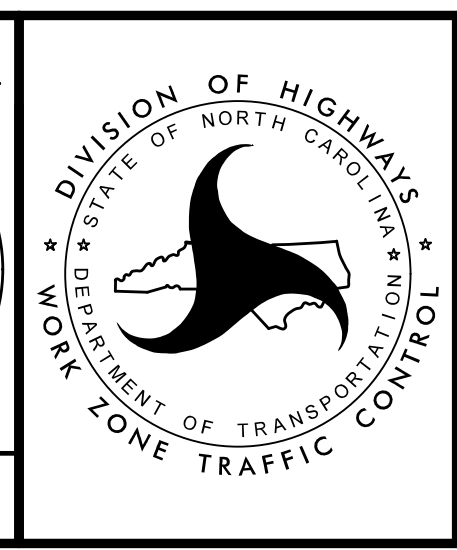

TRANSPORTATION
MANAGEMENT PLAN

PHASE IIA
DETAIL

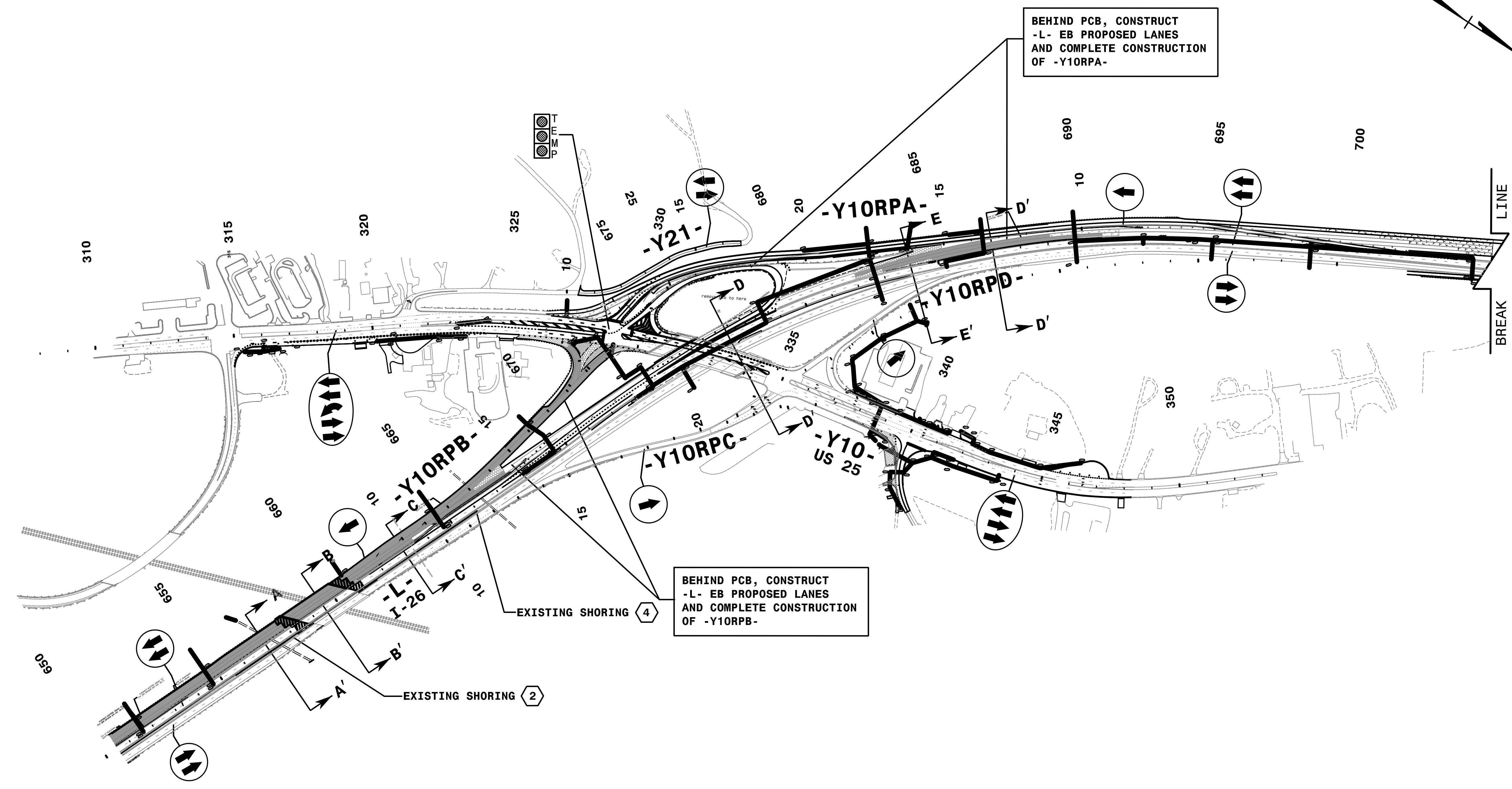
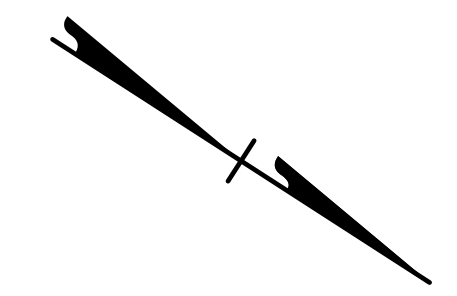

BEHIND PCB, CONSTRUCT
-L- EB PROPOSED LANES
AND COMPLETE CONSTRUCTION
OF -Y10RPA-

BEHIND PCB, CONSTRUCT
-L- EB PROPOSED LANES
AND COMPLETE CONSTRUCTION
OF -Y10RPB-

REFER TO SHEET TMP-56 FOR CUT SECTION(S).

3:22:54 PM
I:\CP\I4400C-1c_PHASE 2b_0v.dgn
9/3/2019

HNTB
HNTB NORTH CAROLINA, P.C.
343 E. Six Forks Road, Suite 200
Raleigh, North Carolina 27609
NC License No: C-1554

APPROVED: *Rhonda B. Early*
DATE: 9/3/2019

**DOCUMENT NOT CONSIDERED FINAL
UNLESS ALL SIGNATURES COMPLETED**

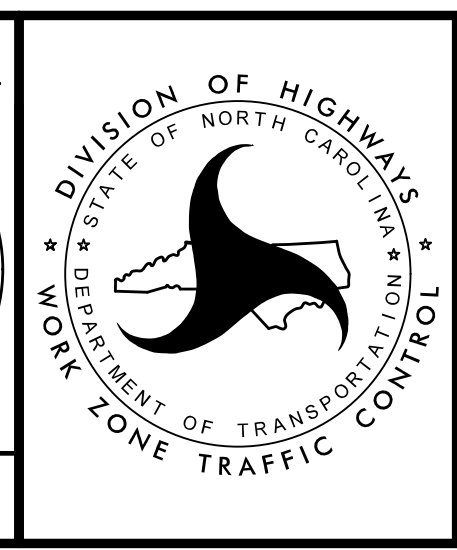

TRANSPORTATION
MANAGEMENT PLAN

PHASE IIB
OVERVIEW

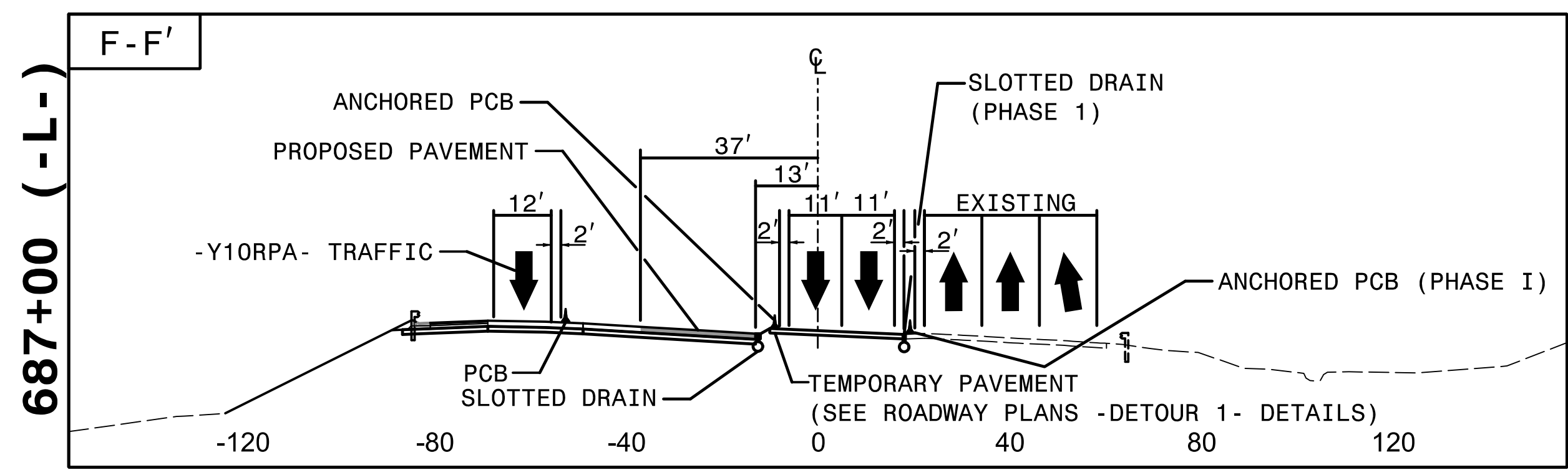
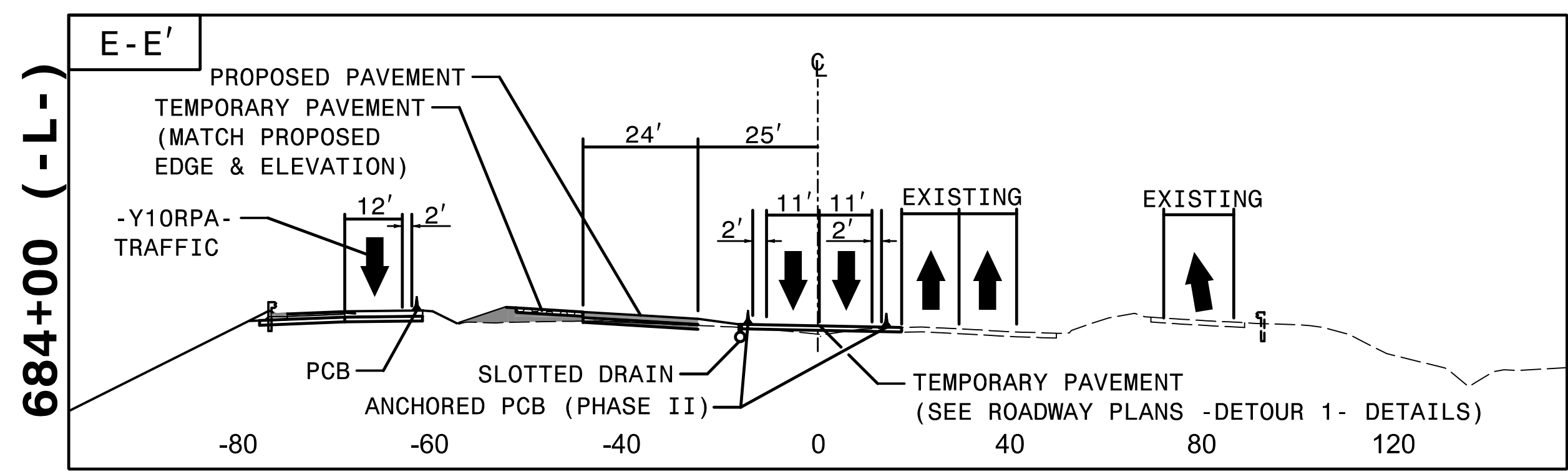
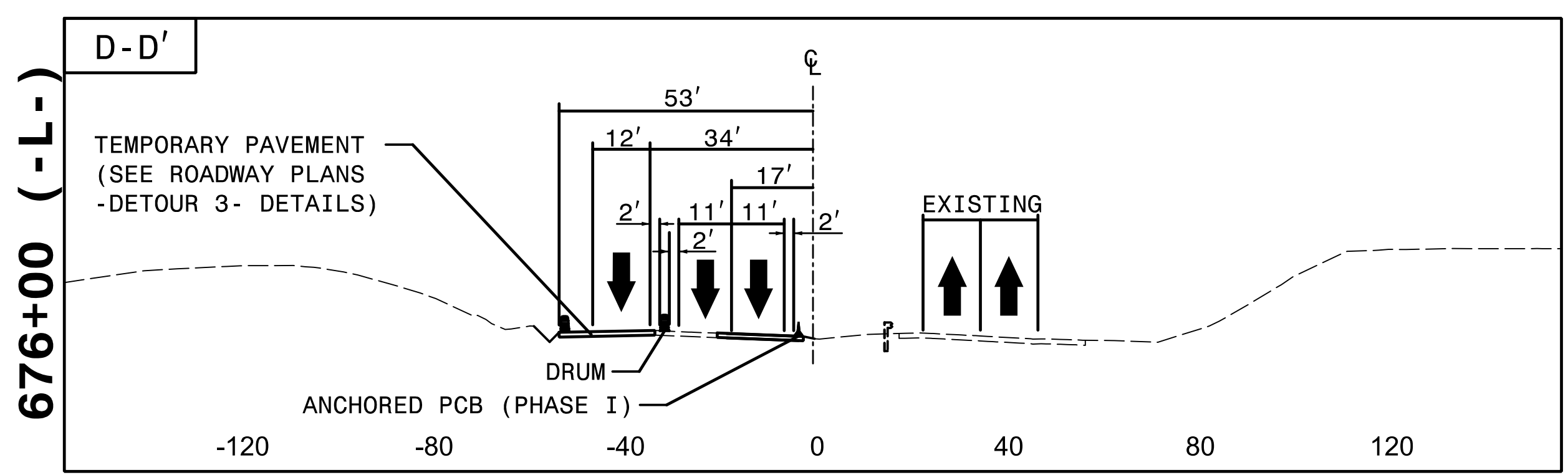
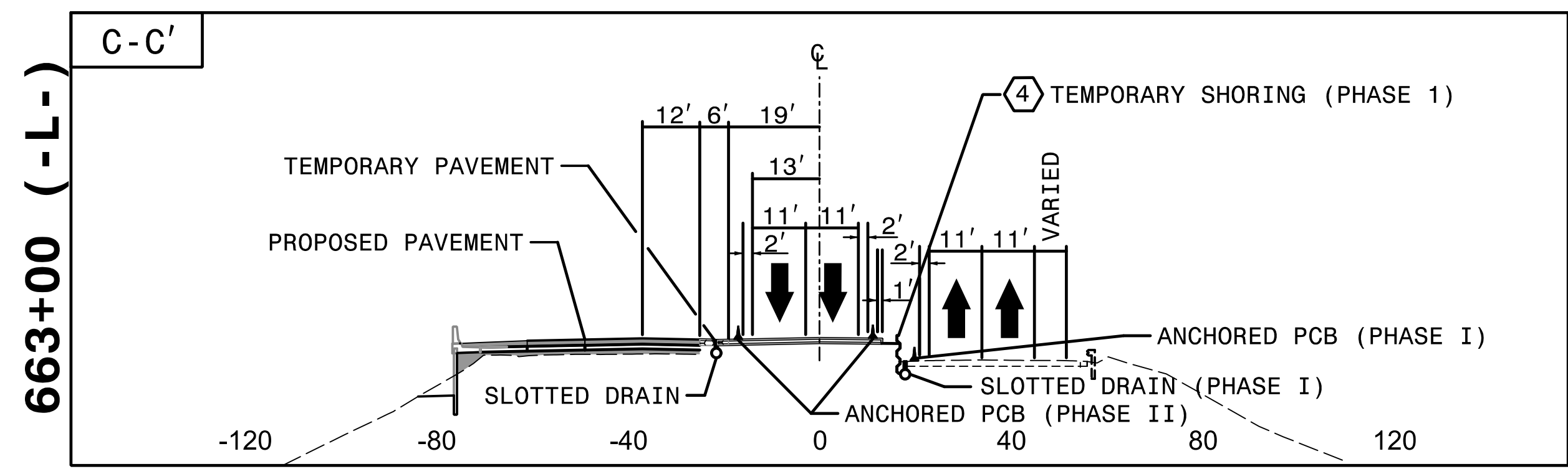
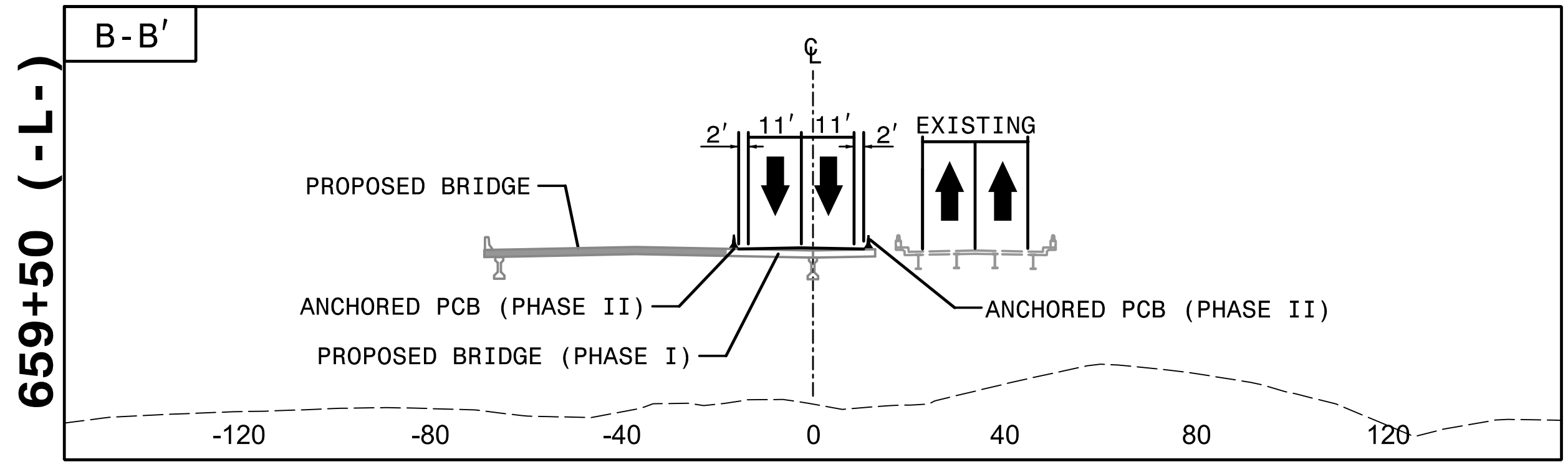
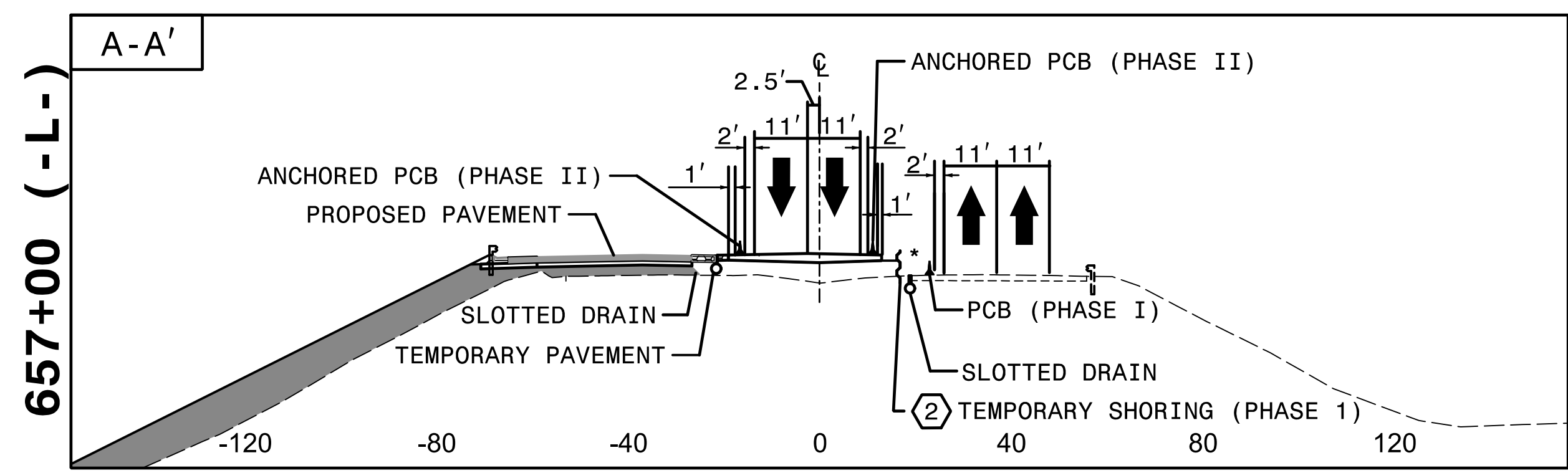

3:23:37 PM
3:\TCN\4400C-TC-P2 CUTS.dgn
9/3/2019



APPROVED: *Rhonda B. Early*
DATE: 9/3/2019

DESIGNED BY: Rhonda B. Early
F34CAFAC0BFB8A

PROFESSIONAL SEAL
NORTH CAROLINA
ENGINEER
RHONDA B. EARLY
023521

DOCUMENT NOT CONSIDERED FINAL UNLESS ALL SIGNATURES COMPLETED

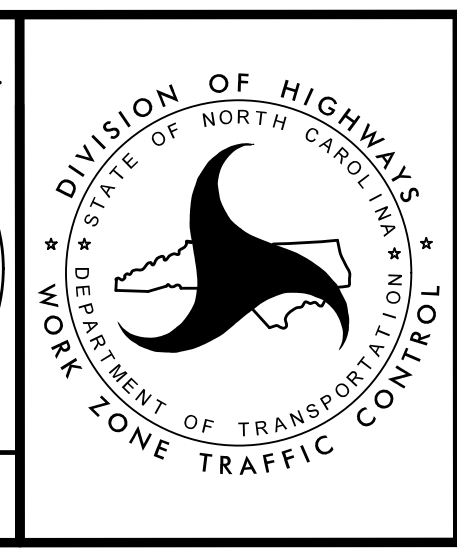

TRANSPORTATION MANAGEMENT PLAN

PHASE IIB CUT SECTIONS

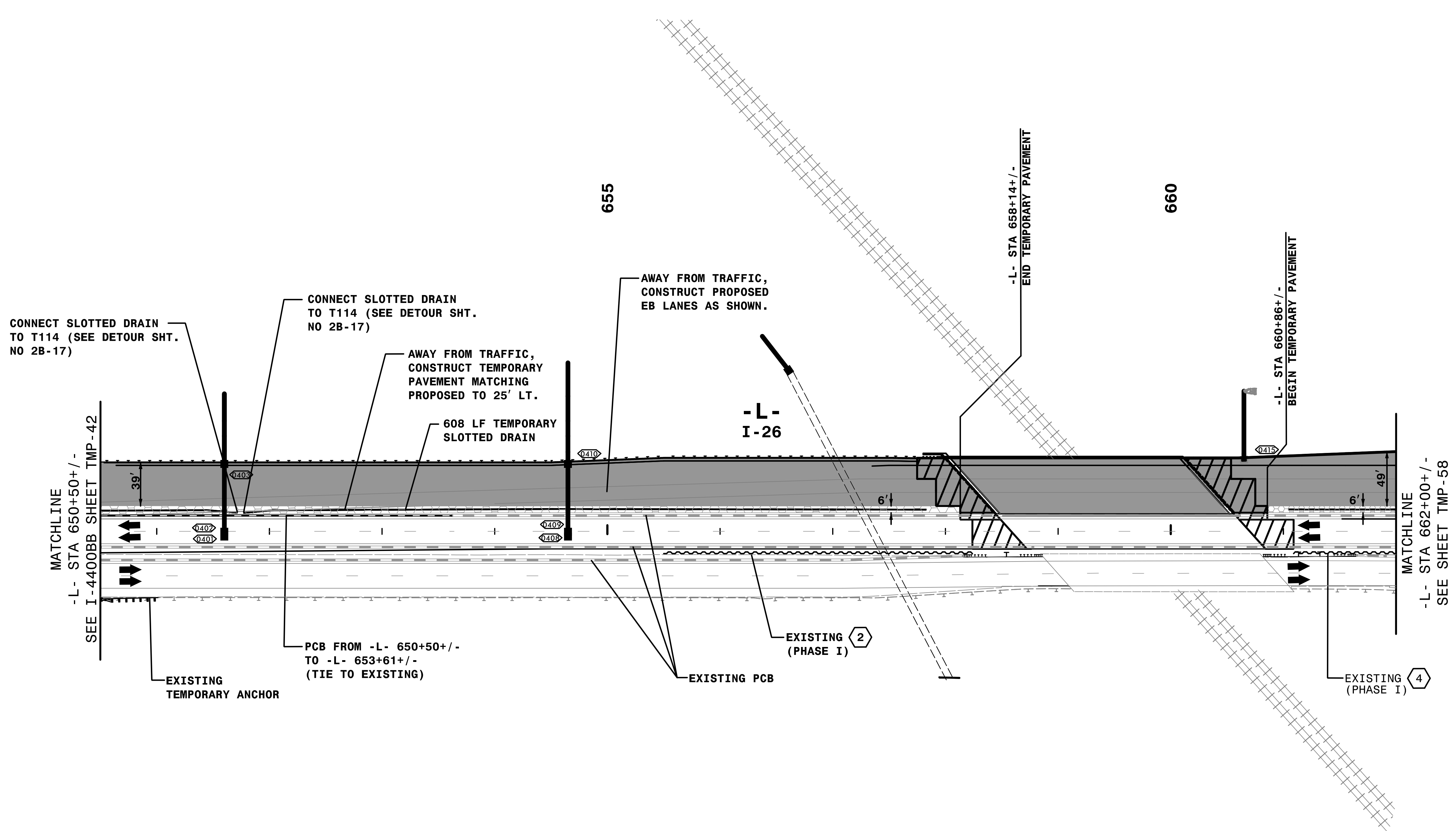
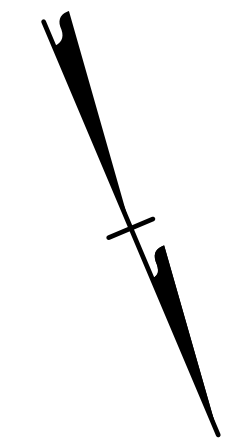

3:23:48 PM
 \\TCN\4400C-TC-ALP2bdl.dgn
 9/3/2019

REMOVE CONFLICTING PAVEMENT MARKING.

HNTB
 HNTB NORTH CAROLINA, P.C.
 343 E. Six Forks Road, Suite 200
 Raleigh, North Carolina 27609
 NC License No: C-1554

APPROVED: *Rhonda B. Early*
DocuSigned by: Rhonda B. Early
F34CAFAC6BFB4A
 DATE: 9/3/2019

**DOCUMENT NOT CONSIDERED FINAL
 UNLESS ALL SIGNATURES COMPLETED**

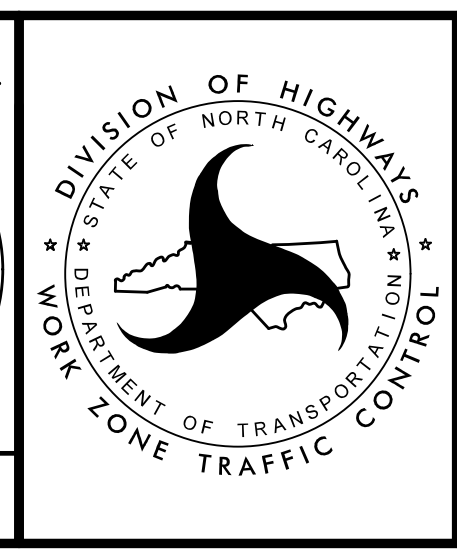

TRANSPORTATION
 MANAGEMENT PLAN

**PHASE IIB
 DETAIL**

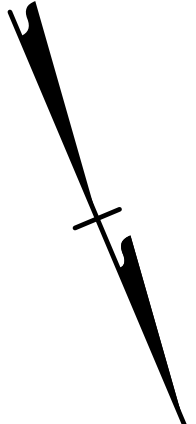
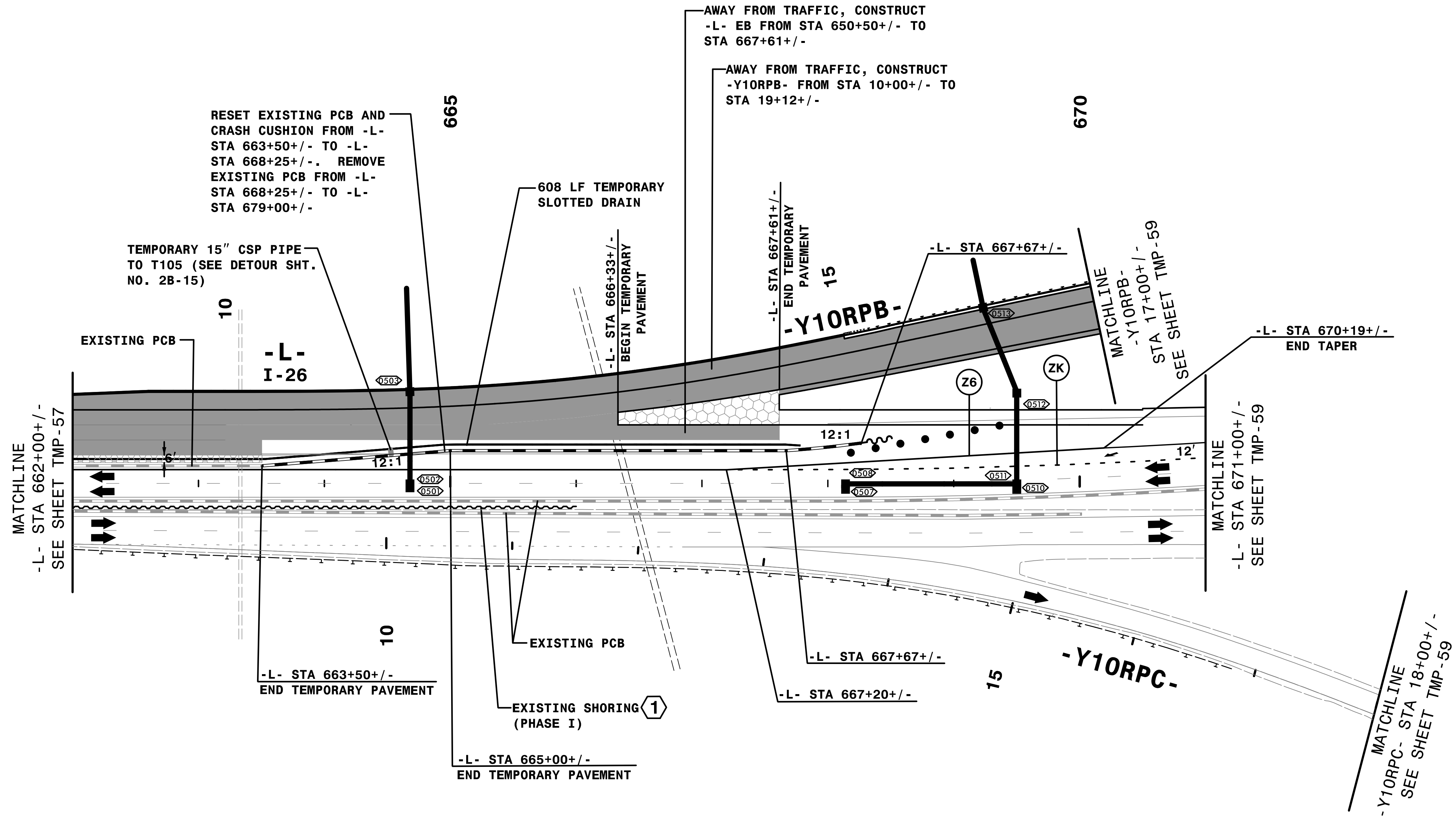

REMOVE CONFLICTING PAVEMENT MARKING.

3:23:57 PM
 TC:\4400C-1c_ALP2b42.dgn
 9/3/2019

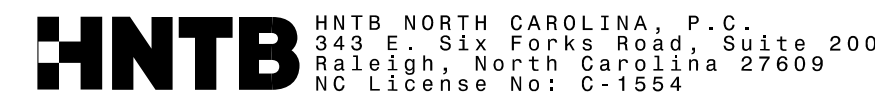

APPROVED: *Rhonda B. Early*
F34CAFAC6BFB4A
 DATE: 9/3/2019

DOCUMENT NOT CONSIDERED FINAL
 UNLESS ALL SIGNATURES COMPLETED

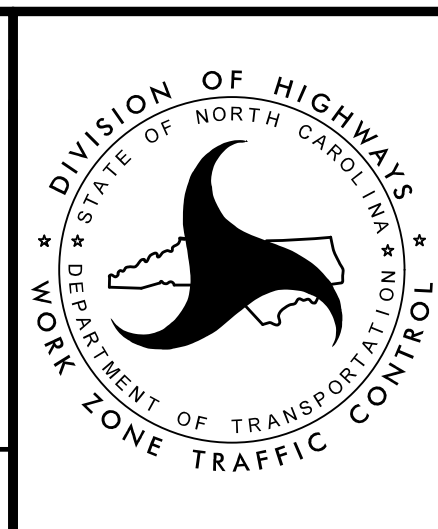

TRANSPORTATION
 MANAGEMENT PLAN

PHASE IIB
 DETAIL

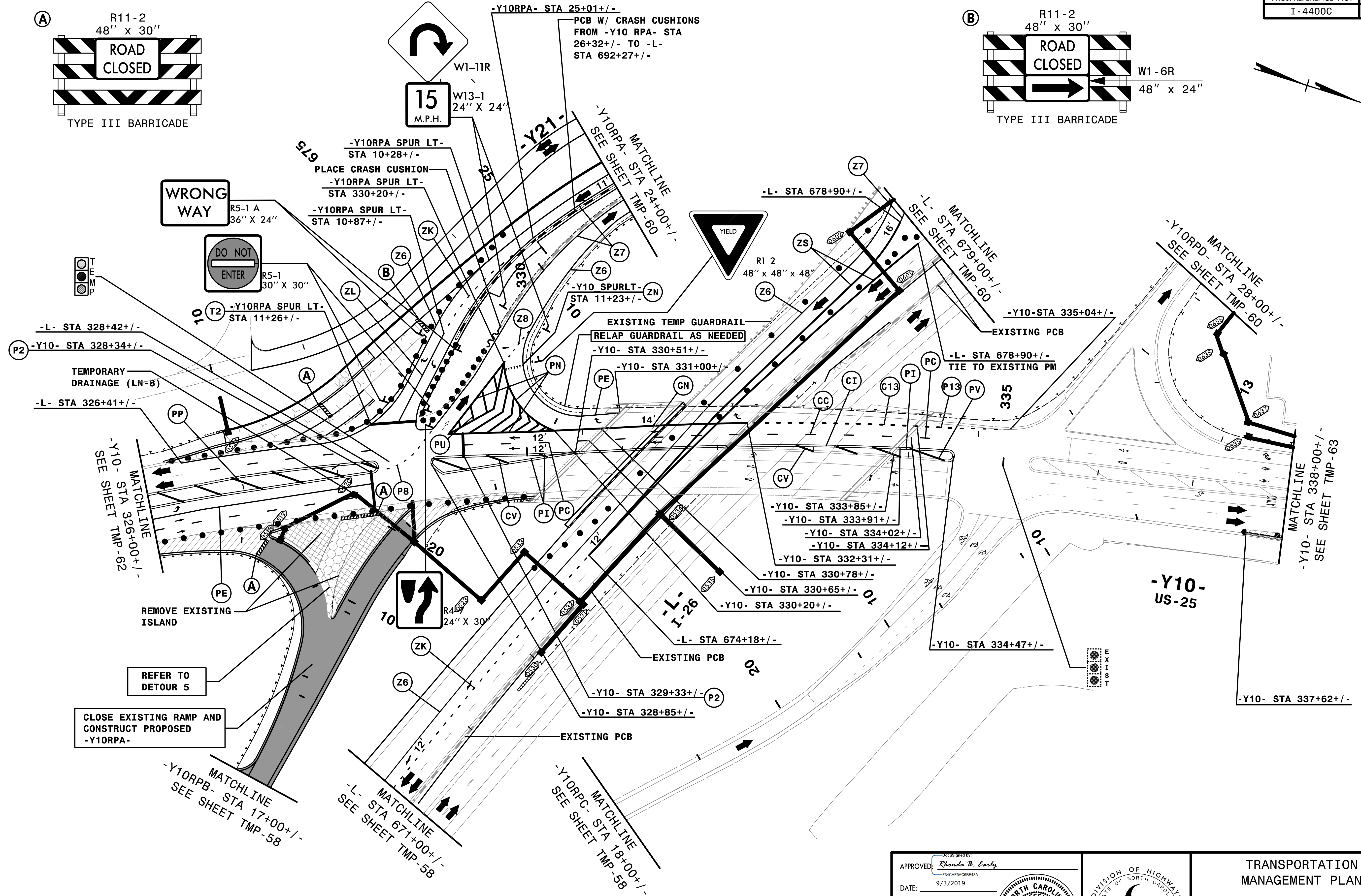
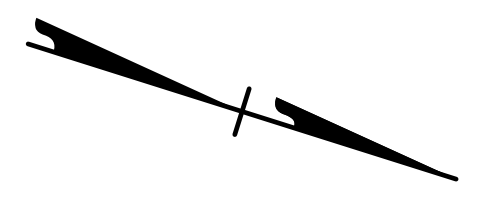
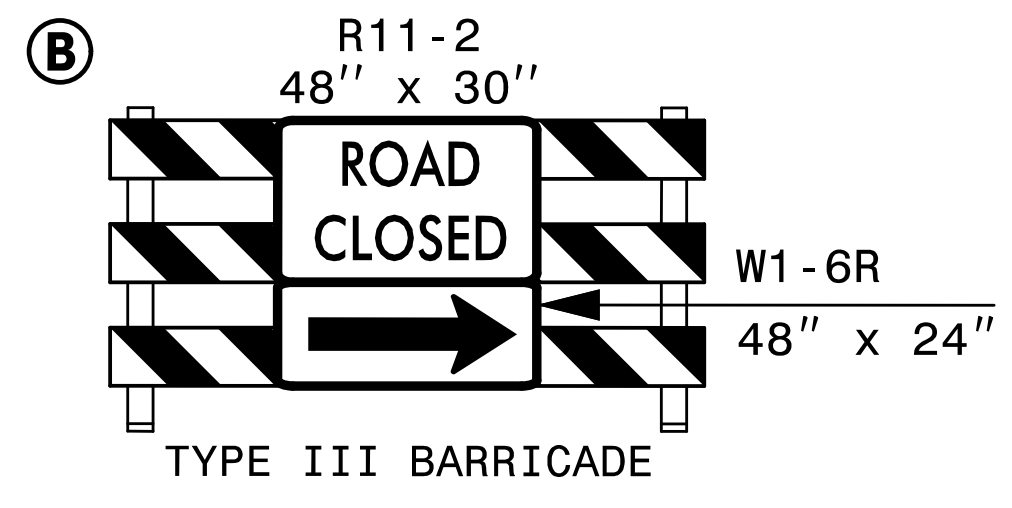
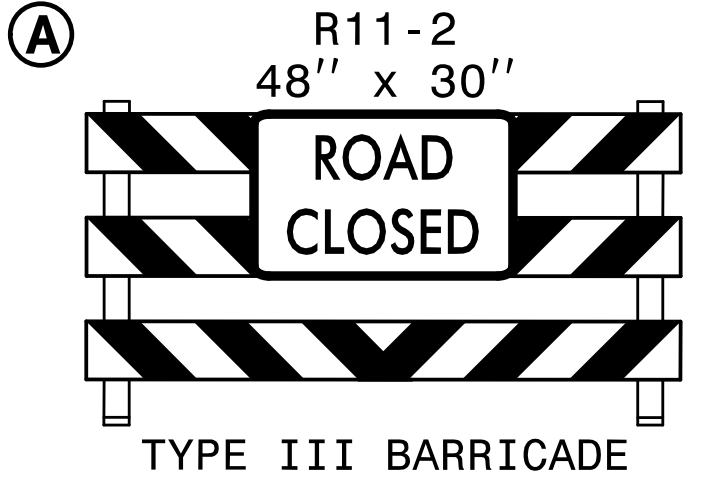

REMOVE CONFLICTING PAVEMENT MARKING.



APPROVED: *Rhonda B. Early*
DATE: 9/3/2019

**DOCUMENT NOT CONSIDERED FINAL
UNLESS ALL SIGNATURES COMPLETED**



TRANSPORTATION
MANAGEMENT PLAN

**PHASE IIB
DETAIL**

3:24:14 PM
\\TCPL\4400C-TC_ALP2b43.dgn
9/3/2019

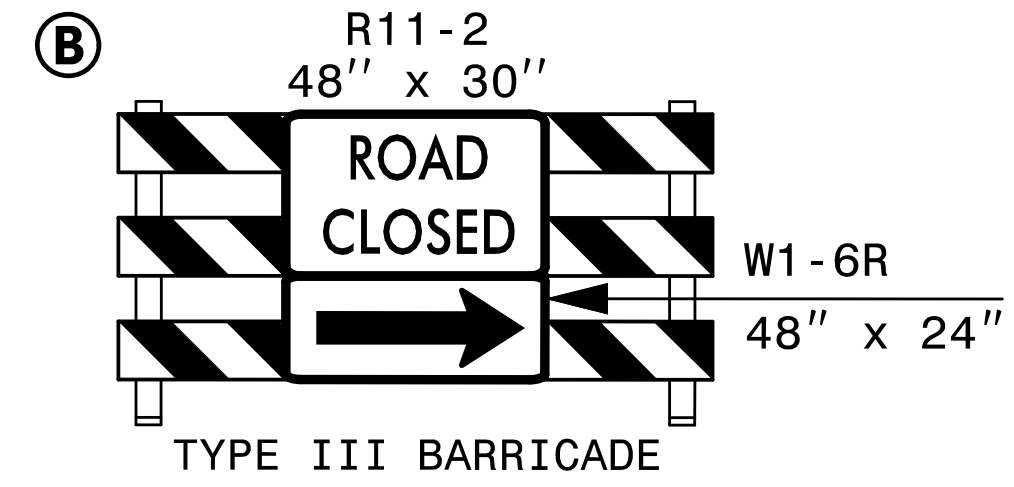
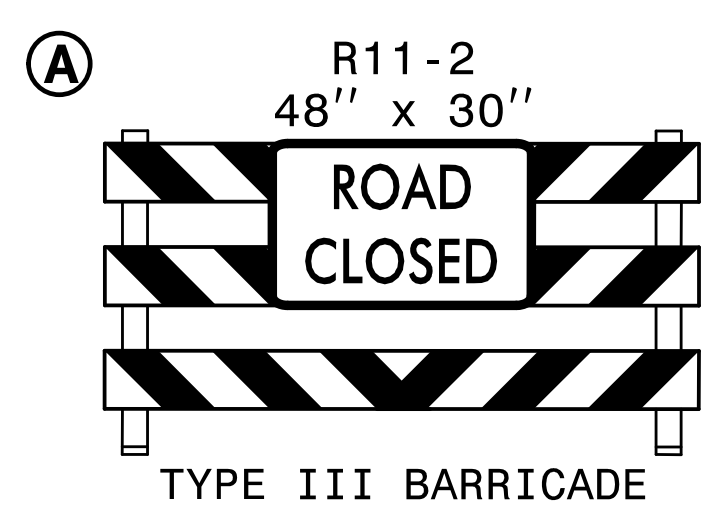
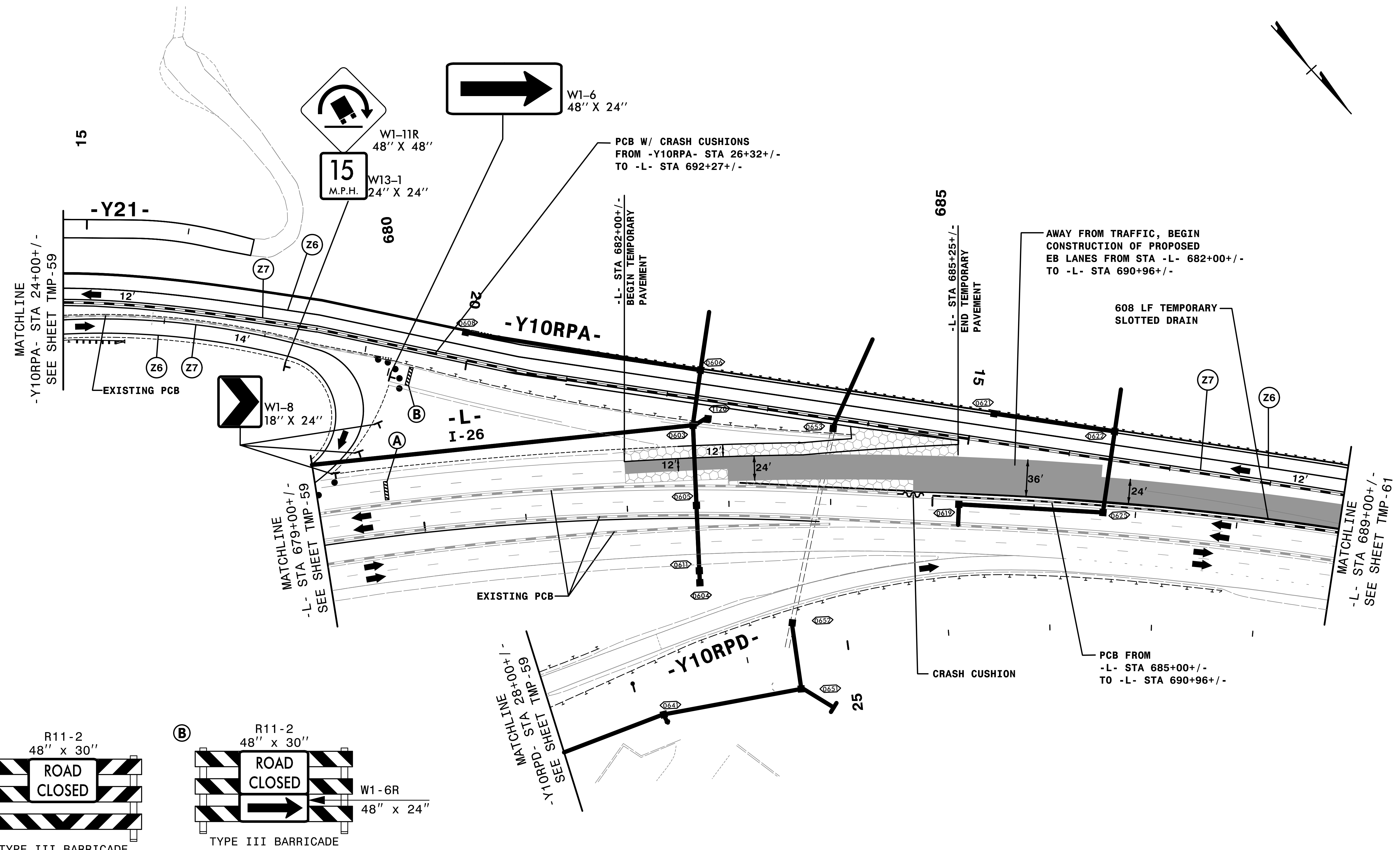

REMOVE CONFLICTING PAVEMENT MARKING.

HNTB
HNTB NORTH CAROLINA, P.C.
343 E. Six Forks Road, Suite 200
Raleigh, North Carolina 27609
NC License No: C-1554

APPROVED: *Rhonda B. Early*
DATE: 9/3/2019
NORTH CAROLINA PROFESSIONAL ENGINEER SEAL 023521
RHONDA B. EARLY



TRANSPORTATION MANAGEMENT PLAN

PHASE IIB
DETAIL

3:24:34 PM
TC:\N\4400C-TC-ALP2b4d4.dgn
9/3/2019

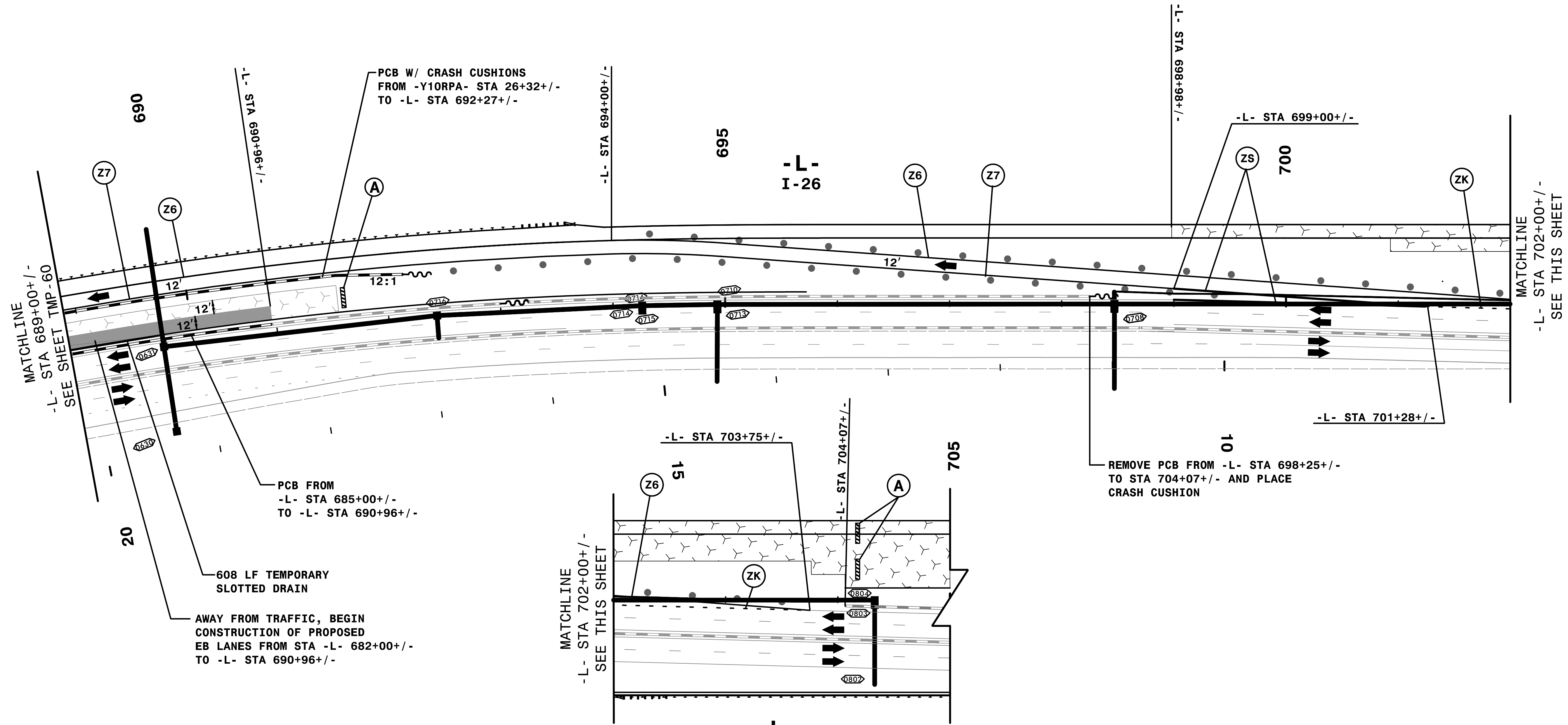
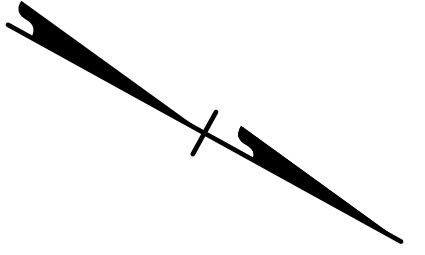
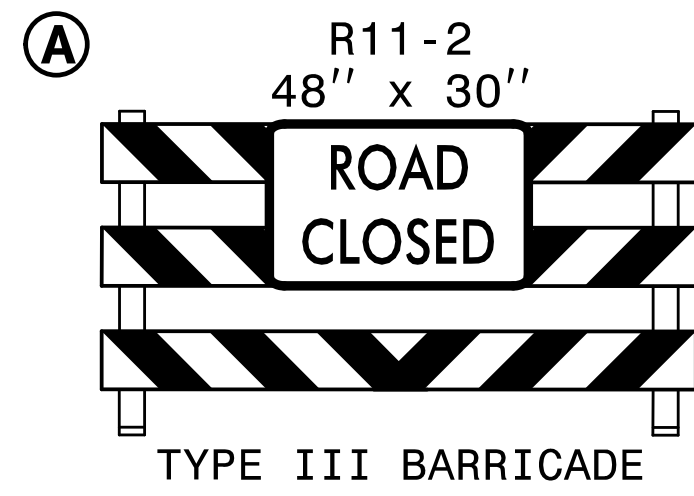

REMOVE CONFLICTING PAVEMENT MARKING.

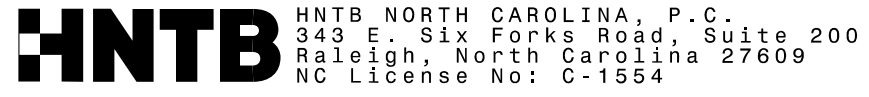

APPROVED: *Rhonda B. Early*
DATE: 9/3/2019

DOCUMENT NOT CONSIDERED FINAL
UNLESS ALL SIGNATURES COMPLETED



TRANSPORTATION
MANAGEMENT PLAN

PHASE IIB
DETAIL

3:24:52 PM
TCN\4400C-TC-ALP2bd5.dgn
9/3/2019

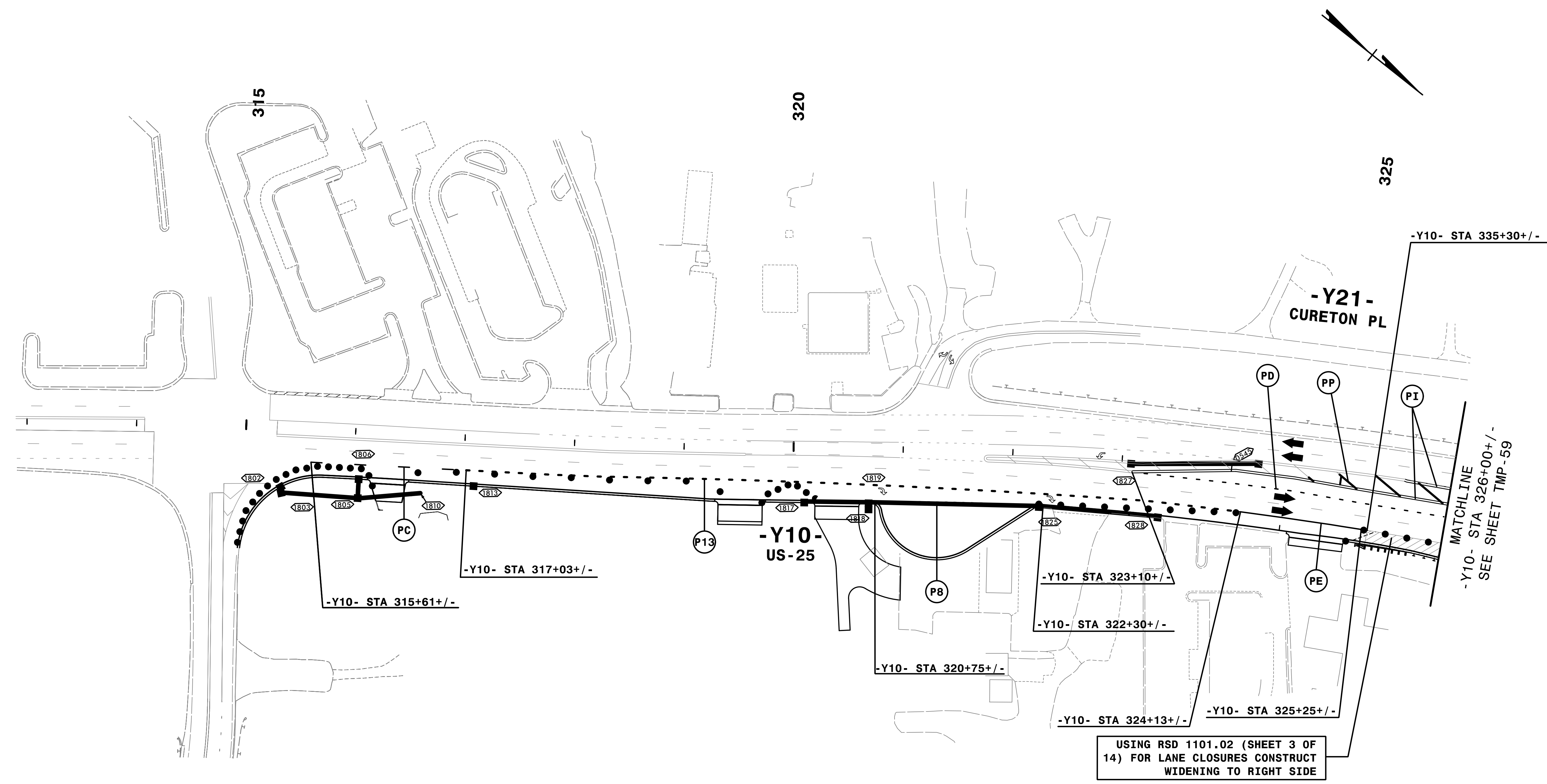

3:25:06 PM
TCN\4400C-TC-ALP2Bd45.dgn
9/3/2019

REMOVE CONFLICTING PAVEMENT MARKING.

HNTB
 HNTB NORTH CAROLINA, P.C.
 343 E. Six Forks Road, Suite 200
 Raleigh, North Carolina 27609
 NC License No: C-1554

DocuSigned by:
APPROVED: Rhonda B. Early
 F34CAFAC6BFB4A
DATE: 9/3/2019

PROFESSIONAL SEAL
 NORTH CAROLINA
 023521
 ENGINEER
 RHONDA B. EARLY

**DOCUMENT NOT CONSIDERED FINAL
 UNLESS ALL SIGNATURES COMPLETED**

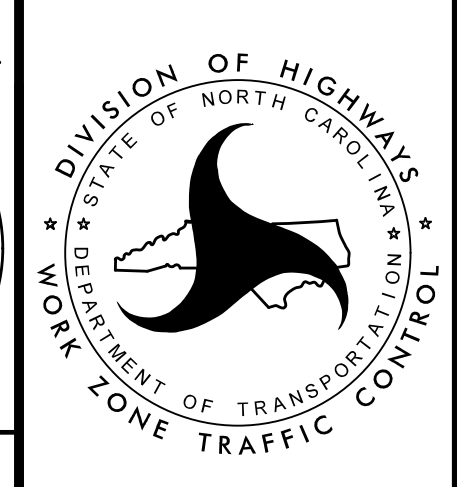

TRANSPORTATION
 MANAGEMENT PLAN

PHASE IIB
 DETAIL

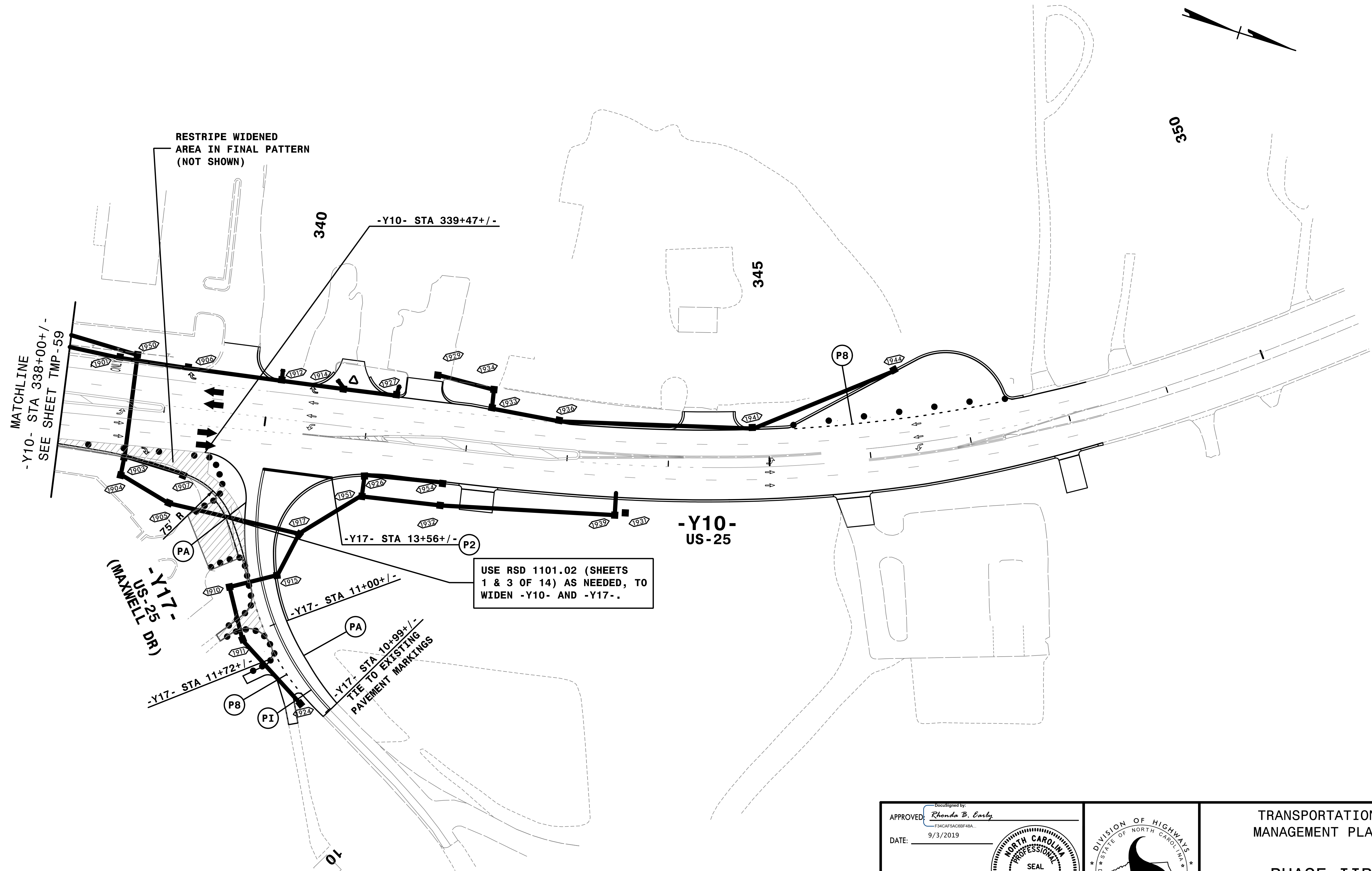

3:25:19 PM
 \\TCN\4400C-TC-ALP2Bd46.dgn
 9/3/2019

REMOVE CONFLICTING PAVEMENT MARKING.

USE RSD 1101.02 (SHEETS 1 & 3 OF 14) AS NEEDED, TO WIDEN -Y10- AND -Y17-.

HNTB
 HNTB NORTH CAROLINA, P.C.
 343 E. Six Forks Road, Suite 200
 Raleigh, North Carolina 27609
 NC License No: C-1554

APPROVED: *Rhonda B. Early*
F34CAFAC6BFB4A
 DATE: 9/3/2019

PROFESSIONAL ENGINEER
 NORTH CAROLINA
 SEAL
 023521
 RHONDA B. EARLY

DOCUMENT NOT CONSIDERED FINAL UNLESS ALL SIGNATURES COMPLETED

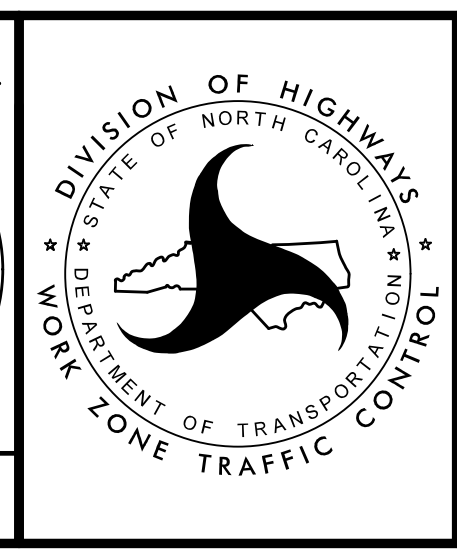

TRANSPORTATION MANAGEMENT PLAN

PHASE IIB DETAIL

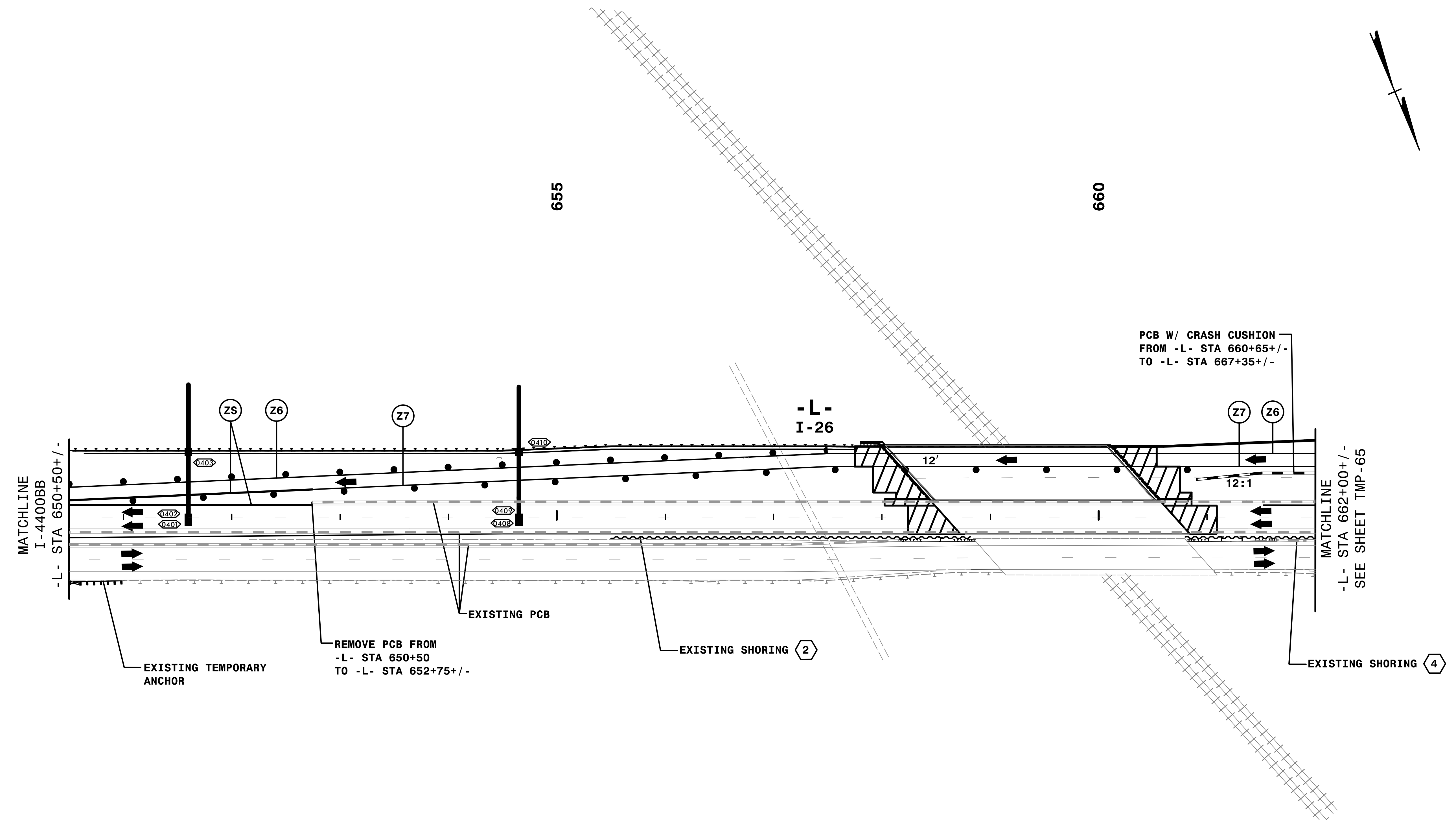
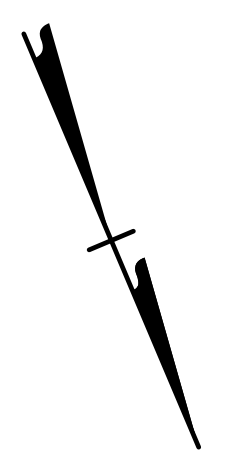

3:25:38 PM
 \\TCN\4400C-TC-ALP2cd1.dgn
 9/3/2019

HNTB
 HNTB NORTH CAROLINA, P.C.
 343 E. Six Forks Road, Suite 200
 Raleigh, North Carolina 27609
 NC License No: C-1554

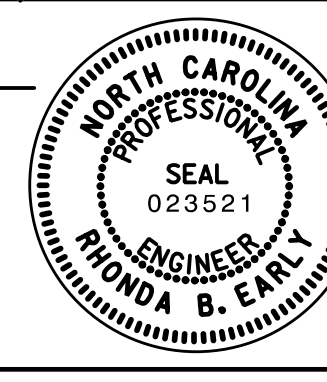
APPROVED: *Rhonda B. Early*
 F34CAFAC6BFB4A
 DATE: 9/3/2019

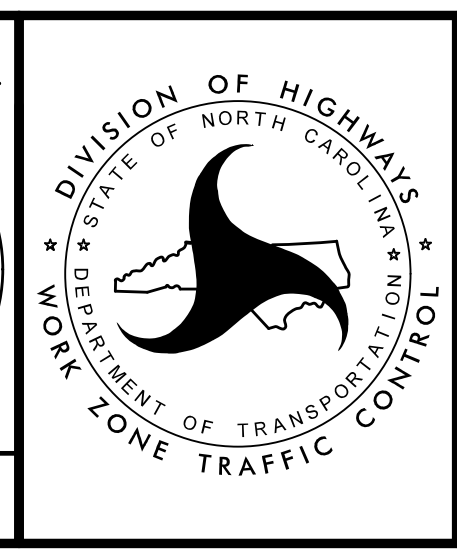
**DOCUMENT NOT CONSIDERED FINAL
UNLESS ALL SIGNATURES COMPLETED**

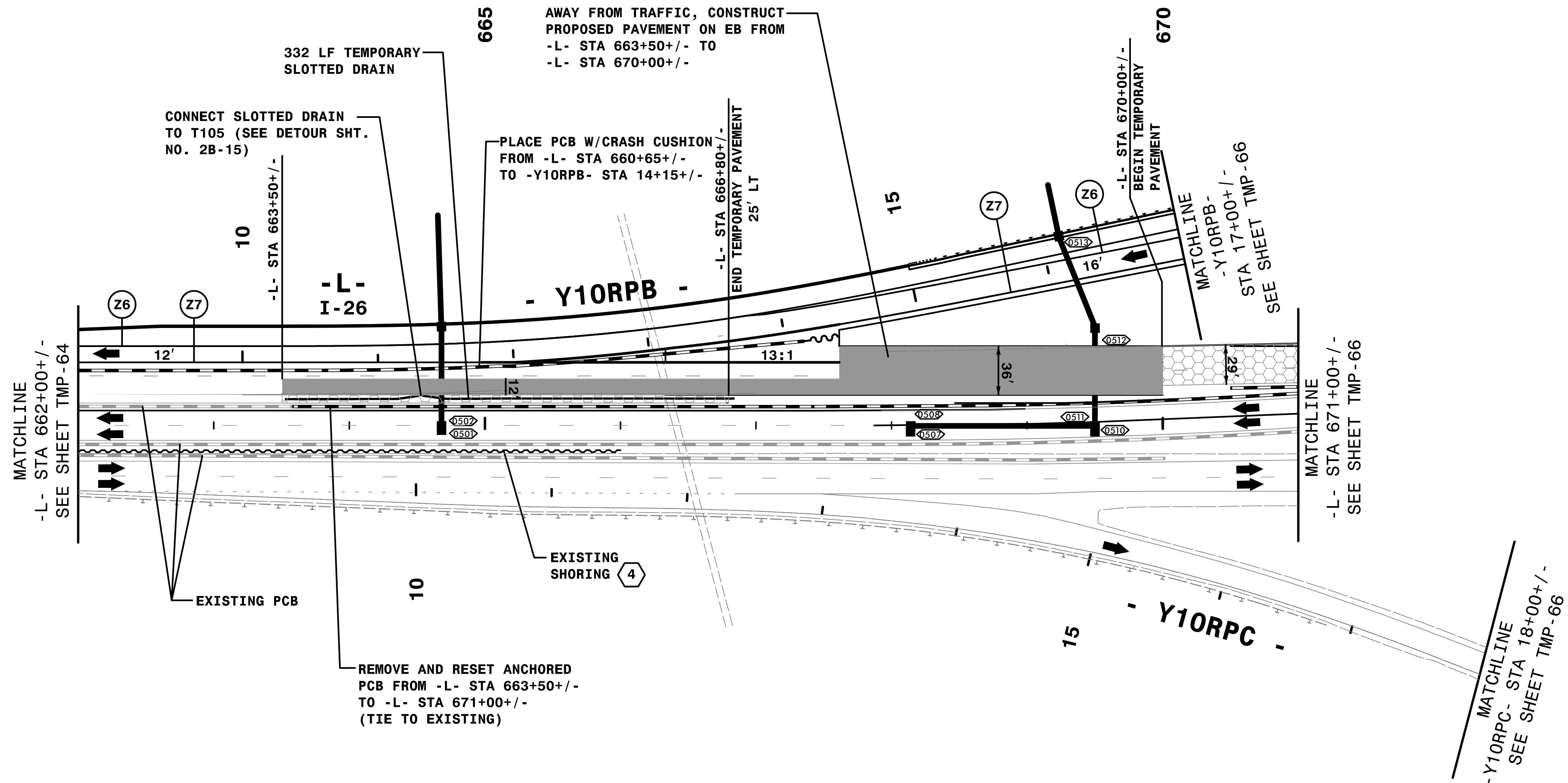

TRANSPORTATION
 MANAGEMENT PLAN

 PHASE IIC
 DETAIL



REMOVE CONFLICTING PAVEMENT MARKING.

3:25:56 PM
TCN\4400C-1c_ALP2cd2.dgn
9/3/2019

HNTB HNTB NORTH CAROLINA, P.C.
343 E. Six Forks Road, Suite 200
Raleigh, North Carolina 27609
NC License No: C-1554

APPROVED: *Rhonda B. Early*
F34CAFAC6BFB4A

DATE: 9/3/2019

PROFESSIONAL ENGINEER
NORTH CAROLINA
SEAL
023521
RHONDA B. EARLY

**DOCUMENT NOT CONSIDERED FINAL
UNLESS ALL SIGNATURES COMPLETED**

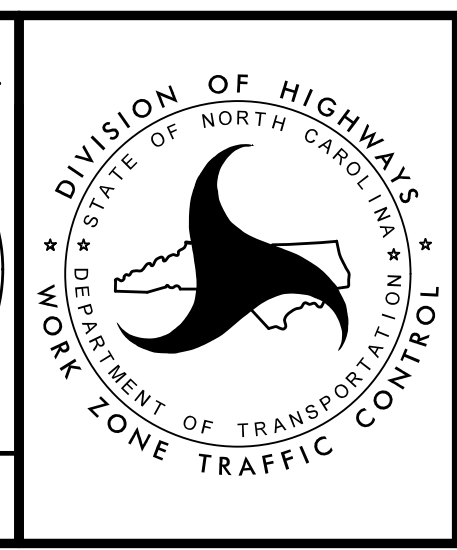

TRANSPORTATION
MANAGEMENT PLAN

PHASE IIC
DETAIL

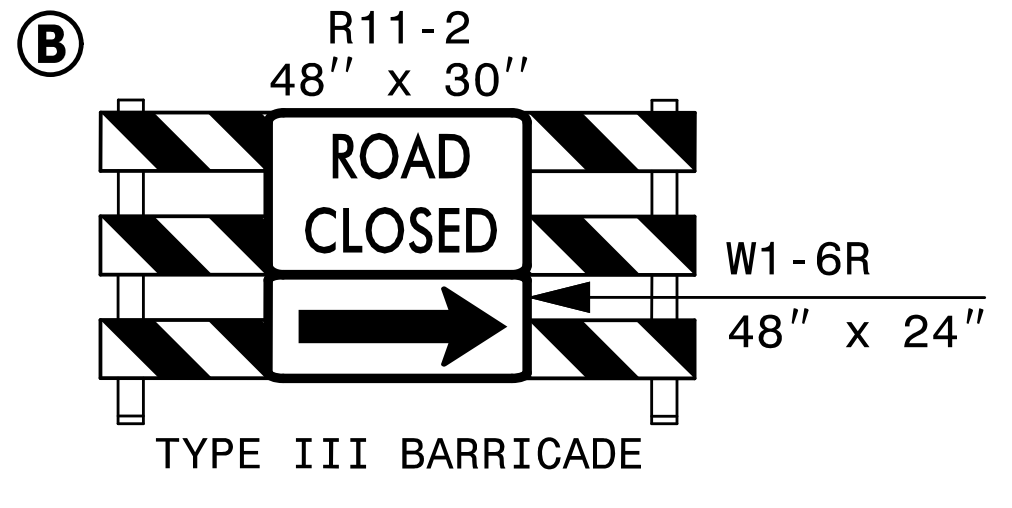
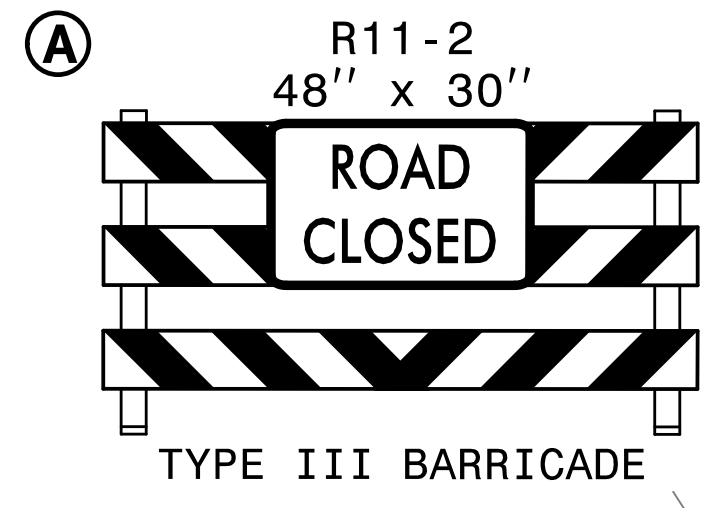

AWAY FROM TRAFFIC, CONSTRUCT
TEMPORARY PAVEMENT ON EB FROM
-L- STA 670+00+/- TO
-L- STA 685+24+/-

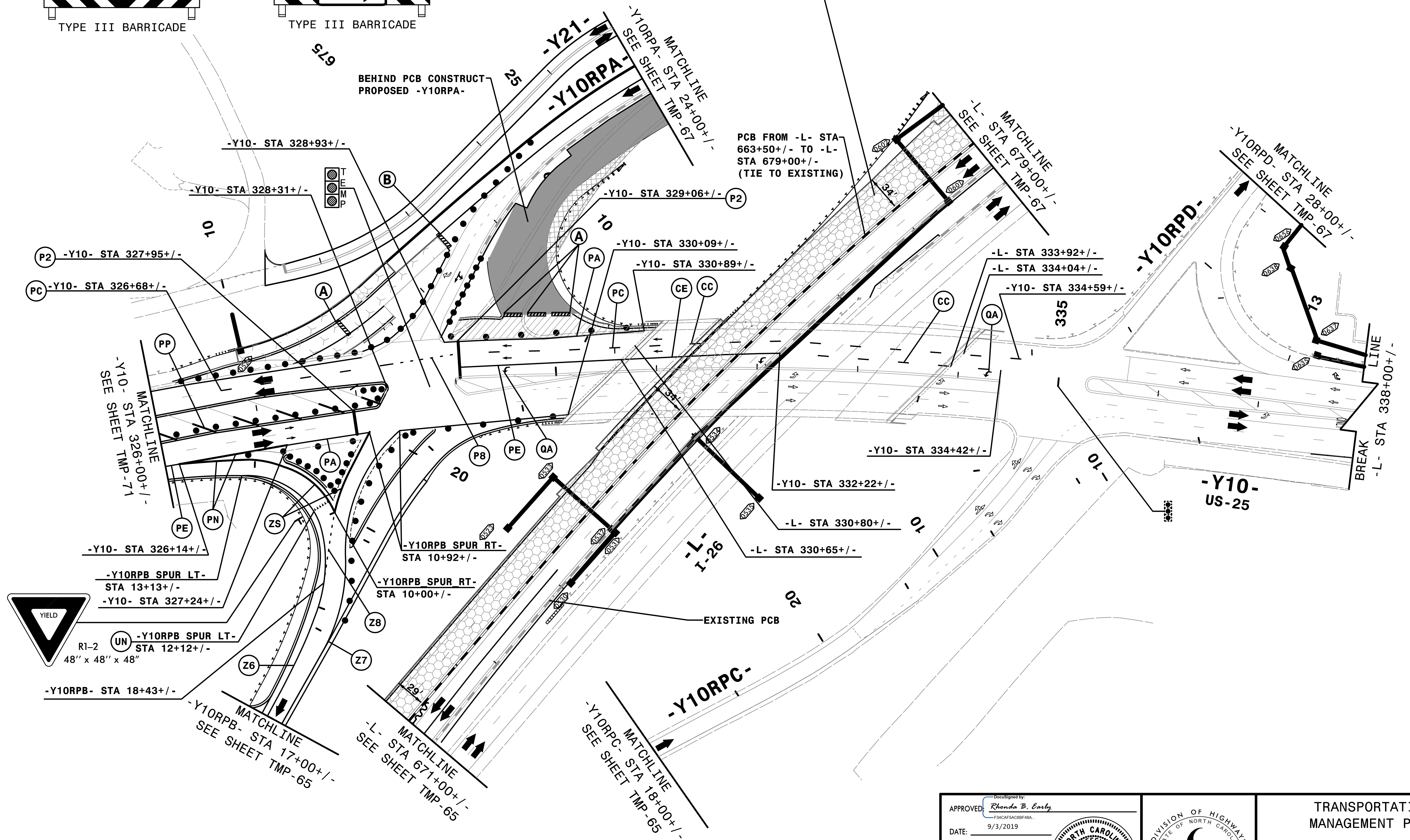
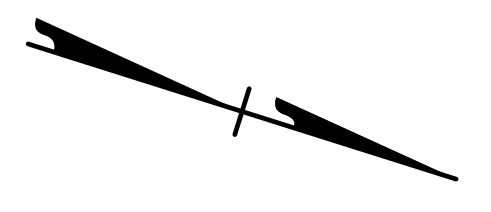

REMOVE CONFLICTING PAVEMENT MARKING.



APPROVED: *Rhonda B. Early*
DATE: 9/3/2019

**DOCUMENT NOT CONSIDERED FINAL
UNLESS ALL SIGNATURES COMPLETED**

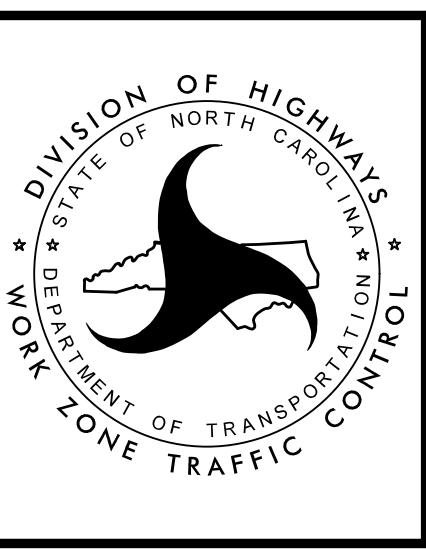

TRANSPORTATION
MANAGEMENT PLAN

PHASE IIC
DETAIL

3:26:17 PM
TC:\N\4400C-TC-ALP2cd3.dgn
9/3/2019

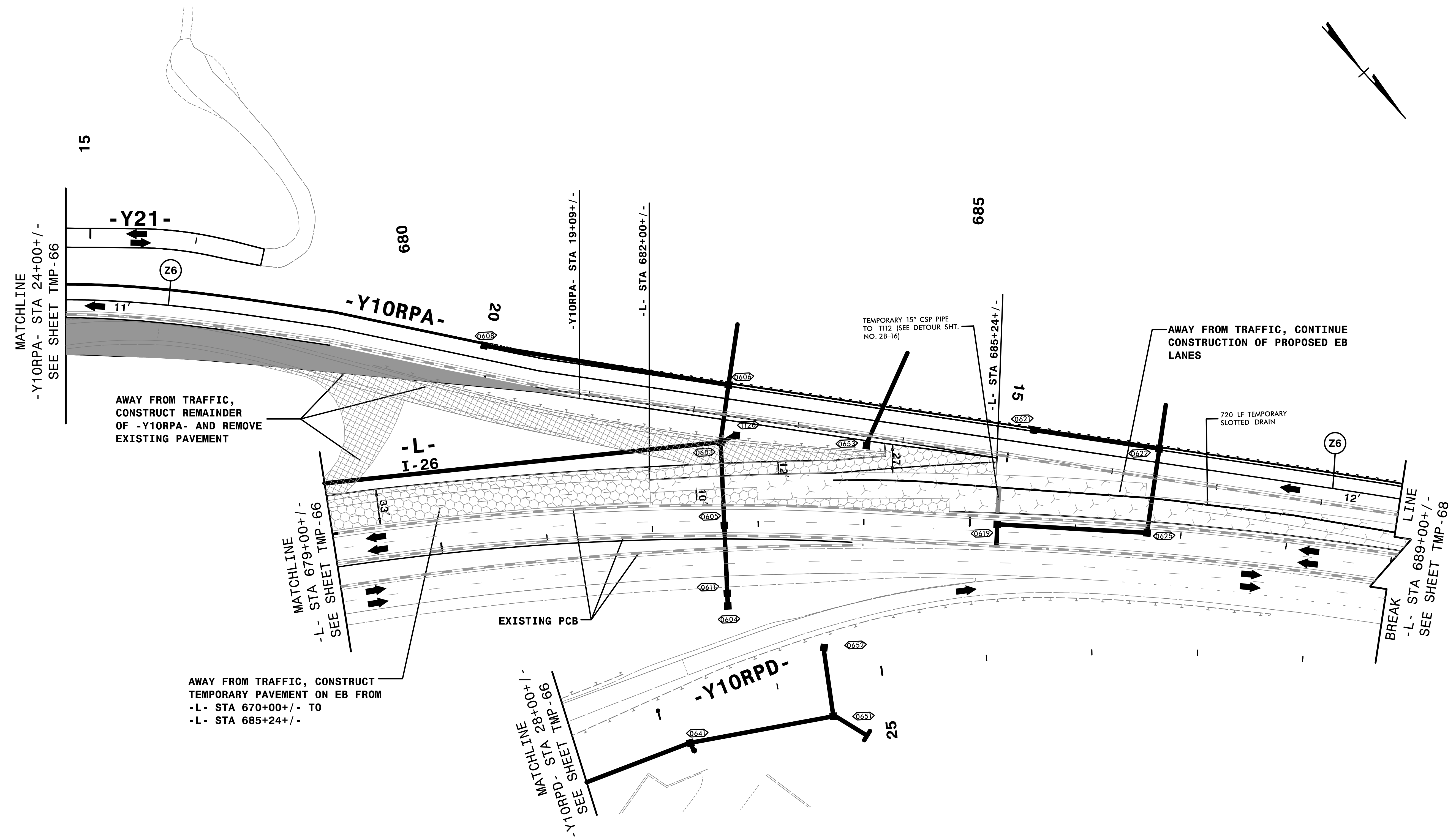

3:26:35 PM
\\TCN\4400C-TC-ALP2cd4.dgn
9/3/2019

HNTB
 HNTB NORTH CAROLINA, P.C.
 349 E. Six Forks Road, Suite 200
 Raleigh, North Carolina 27609
 NC License No: C-1554

DocuSigned by:
 APPROVED: *Rhonda B. Early*
 F34CAFAC6BFB4A
 DATE: 9/3/2019

PROFESSIONAL ENGINEER SEAL
 NORTH CAROLINA
 023521
 RHONDA B. EARLY

DOCUMENT NOT CONSIDERED FINAL UNLESS ALL SIGNATURES COMPLETED

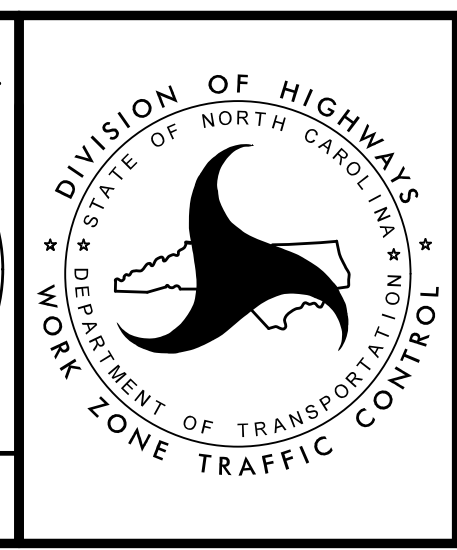

TRANSPORTATION MANAGEMENT PLAN

PHASE IIC DETAIL

SEE TMP-74 THRU TMP-89 FOR EB -L- MARKING AND PCB

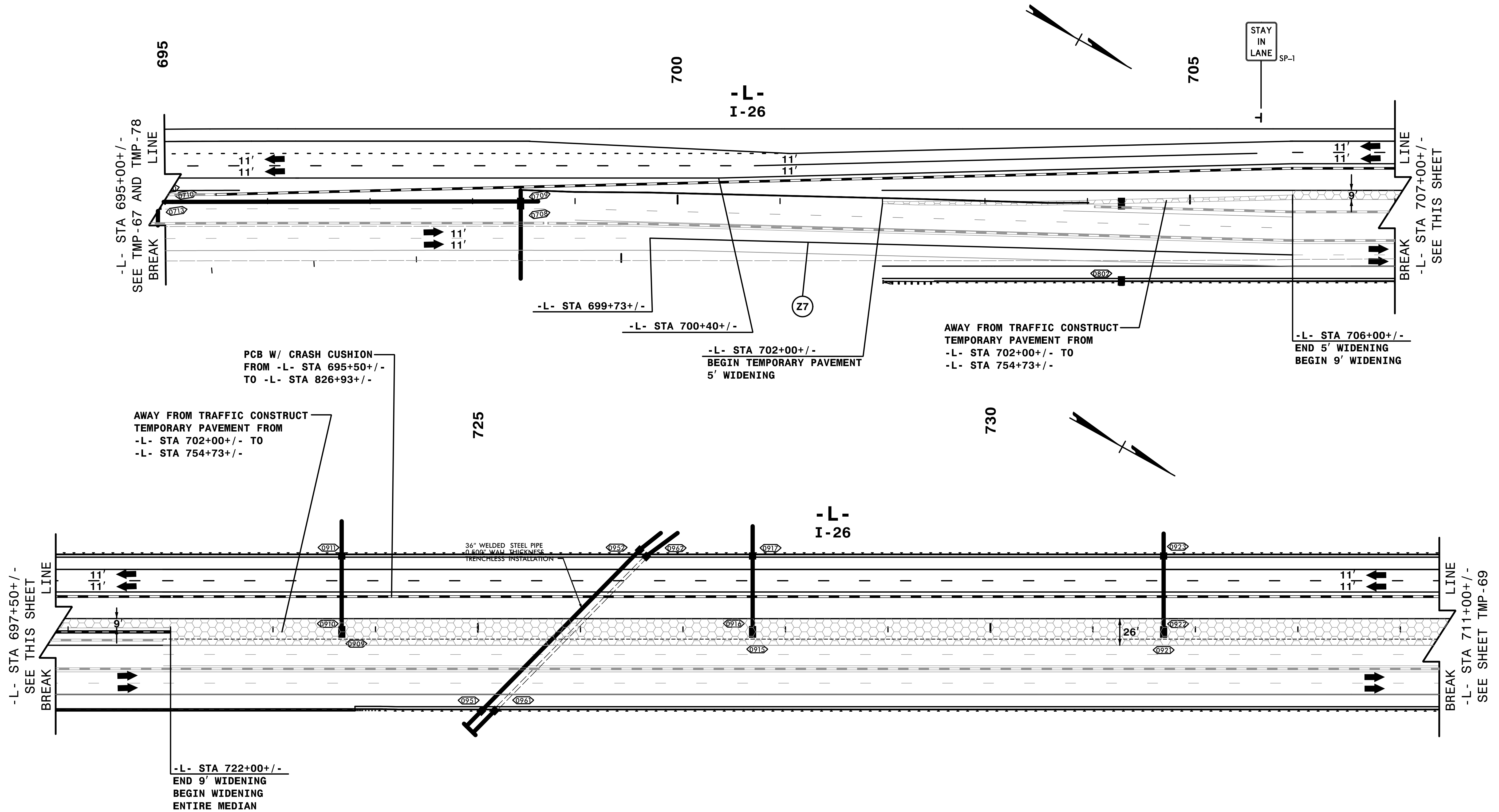

3:26:56 PM
\\TCN\4400C-TC-A3_P2Cdl.dgn
9/3/2019

REMOVE CONFLICTING PAVEMENT MARKING.

HNTB
 HNTB NORTH CAROLINA, P.C.
 343 E. Six Forks Road, Suite 200
 Raleigh, North Carolina 27609
 NC License No: C-1554

APPROVED: *Rhonda B. Early*
 DATE: 9/3/2019

PROFESSIONAL ENGINEER
 NORTH CAROLINA
 SEAL
 023521
 RHONDA B. EARLY

**DOCUMENT NOT CONSIDERED FINAL
 UNLESS ALL SIGNATURES COMPLETED**

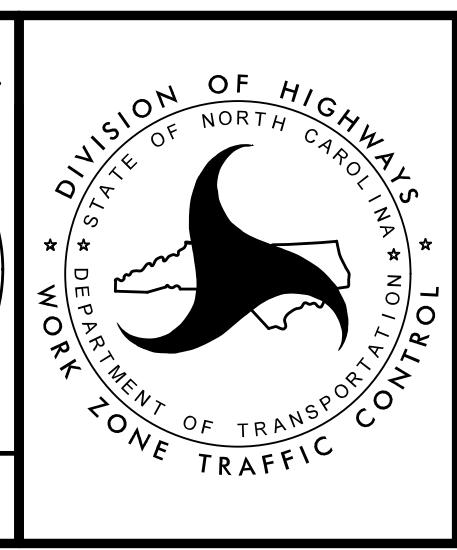

TRANSPORTATION
 MANAGEMENT PLAN

PHASE IIC
 DETAIL

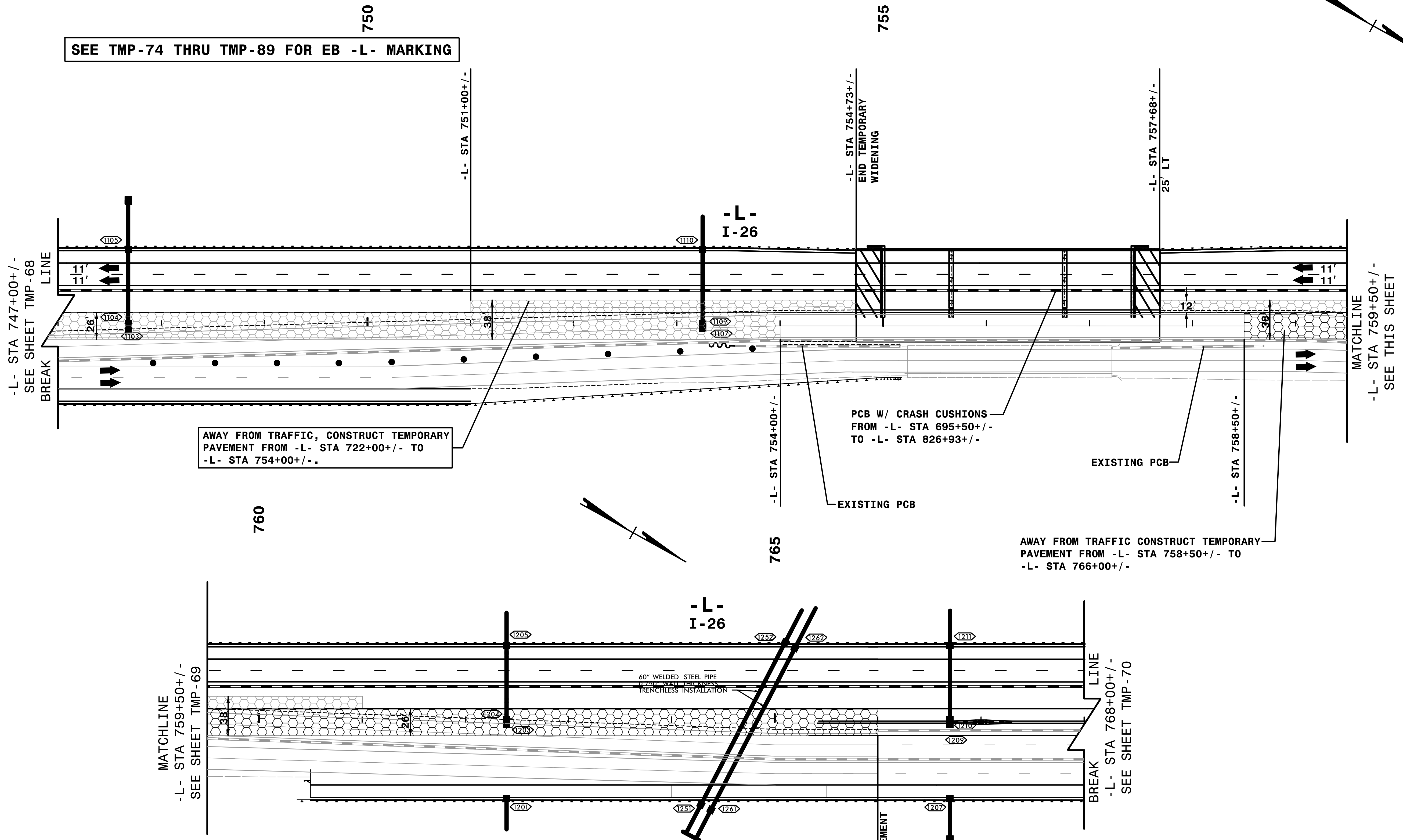

SEE TMP-74 THRU TMP-89 FOR EB -L- MARKING

AWAY FROM TRAFFIC, CONSTRUCT TEMPORARY PAVEMENT FROM -L- STA 722+00+/- TO -L- STA 754+00+/-.

PCB W/ CRASH CUSHIONS FROM -L- STA 695+50+/- TO -L- STA 826+93+/-

AWAY FROM TRAFFIC CONSTRUCT TEMPORARY PAVEMENT FROM -L- STA 758+50+/- TO -L- STA 766+00+/-

3:27:16 PM
\\TCPL\4400C-1c-A3_P2Cd2.dgn
9/3/2019

HNTB
 HNTB NORTH CAROLINA, P.C.
 343 E. Six Forks Road, Suite 200
 Raleigh, North Carolina 27609
 NC License No: C-1554

APPROVED: *Rhonda B. Early*
 DATE: 9/3/2019

PROFESSIONAL ENGINEER
 NORTH CAROLINA
 SEAL
 023521
 RHONDA B. EARLY

DOCUMENT NOT CONSIDERED FINAL UNLESS ALL SIGNATURES COMPLETED

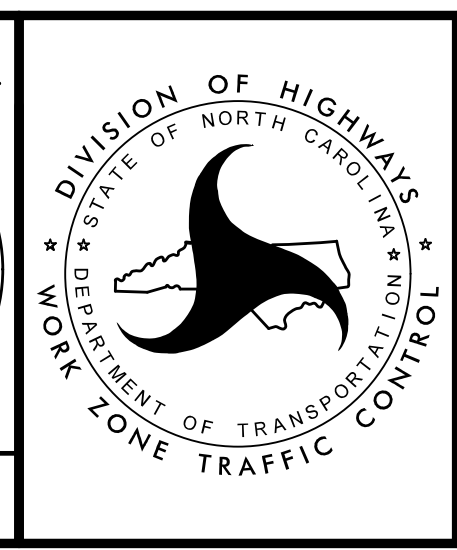

TRANSPORTATION MANAGEMENT PLAN

PHASE IIC DETAIL

SEE TMP-74 THRU TMP-89 FOR EB -L- MARKING

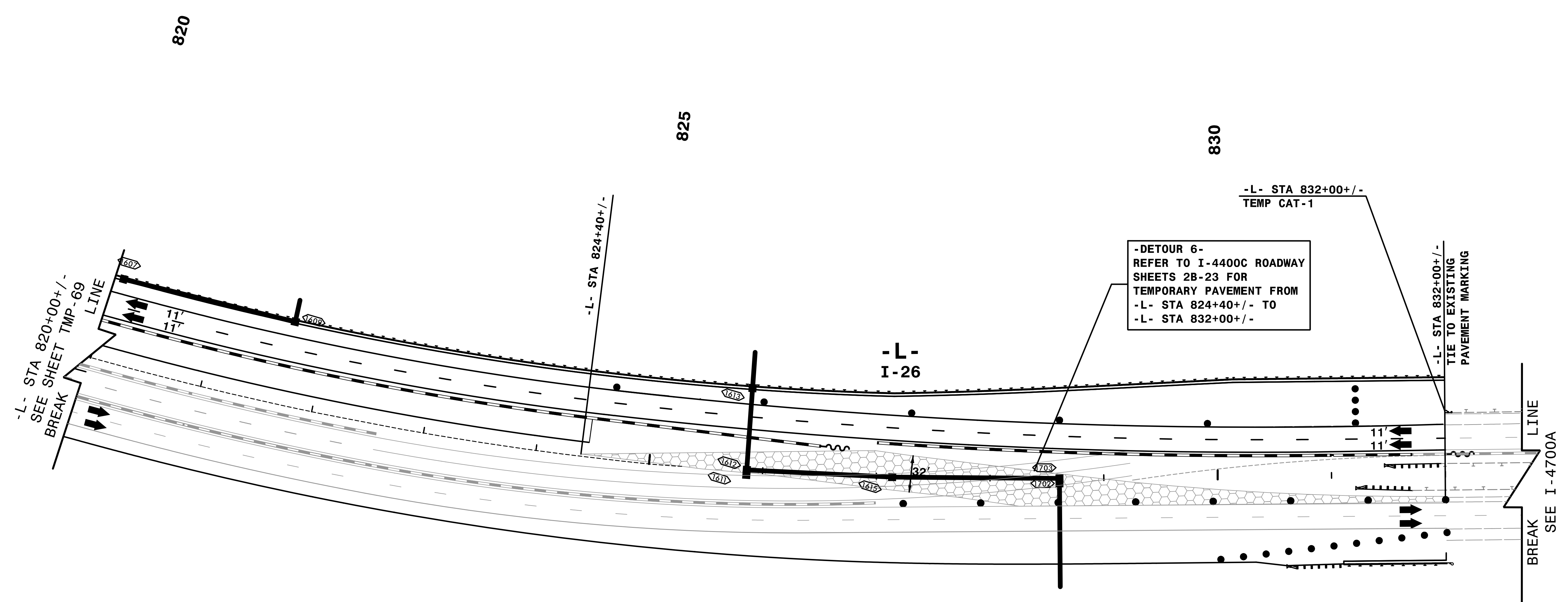
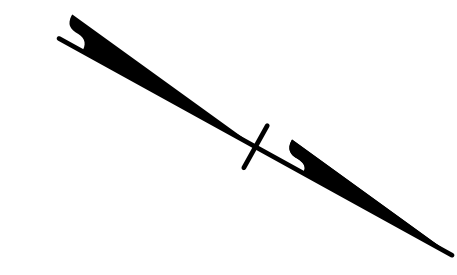

3:27:35 PM
I:\CP\4400C-1c-A3_P2Cd3.dgn
9/3/2019

HNTB
 HNTB NORTH CAROLINA, P.C.
 343 E. Six Forks Road, Suite 200
 Raleigh, North Carolina 27609
 NC License No: C-1554

APPROVED: *Rhonda B. Early*
 F34CAFAC6BFB4A
 DATE: 9/3/2019

PROFESSIONAL ENGINEER
 NORTH CAROLINA
 SEAL
 023521
 RHONDA B. EARLY

**DOCUMENT NOT CONSIDERED FINAL
 UNLESS ALL SIGNATURES COMPLETED**

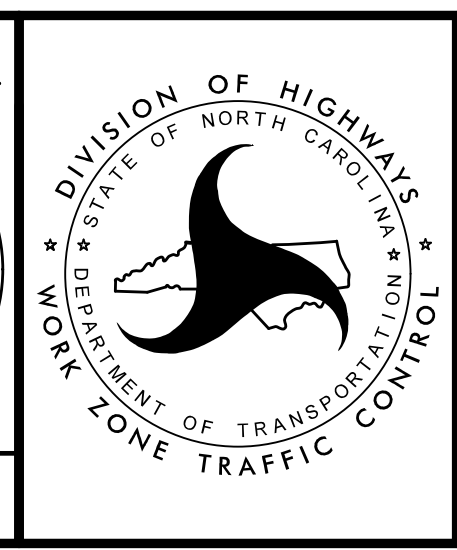

TRANSPORTATION
 MANAGEMENT PLAN

PHASE IIC
 DETAIL

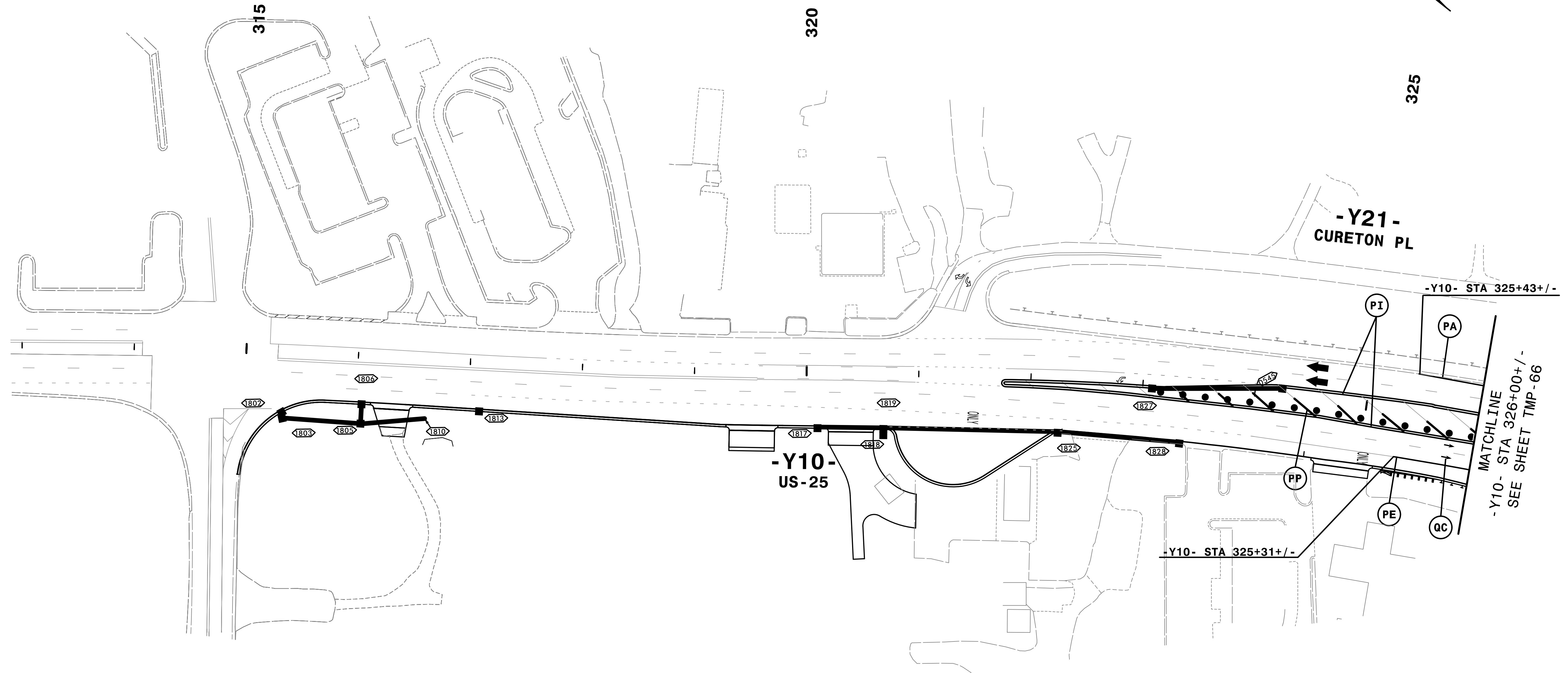

-Y21-
CURETON PL

-Y10-
US-25

-Y10- STA 325+43+/-

-Y10- STA 325+31+/-

MATCHLINE
-Y10- STA 326+00+/-
SEE SHEET TMP-66

REMOVE CONFLICTING PAVEMENT MARKING.

3:28:01 PM
\\TCN\4400C - tc_ALP2C445.dgn
9/3/2019

HNTB
HNTB NORTH CAROLINA, P.C.
343 E. Six Forks Road, Suite 200
Raleigh, North Carolina 27609
NC License No: C-1554

APPROVED: *Rhonda B. Early*
DATE: 9/3/2019

DocuSigned by:
Rhonda B. Early
F34CAFAC6BFB4A

NORTH CAROLINA
PROFESSIONAL
SEAL
023521
ENGINEER
RHONDA B. EARLY

**DOCUMENT NOT CONSIDERED FINAL
UNLESS ALL SIGNATURES COMPLETED**



TRANSPORTATION
MANAGEMENT PLAN

PHASE IIC
DETAIL

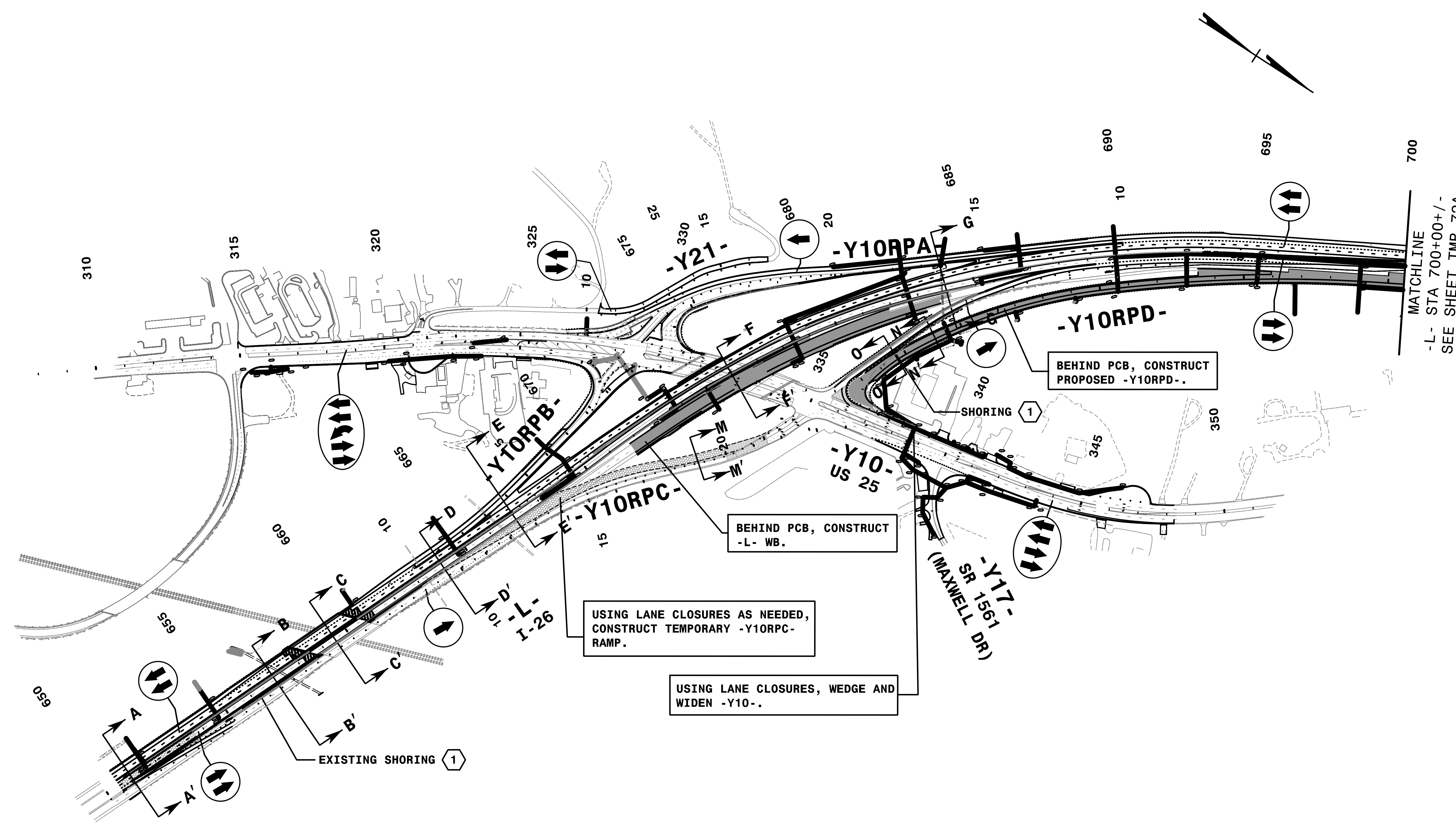

3:33:31PM
 \\TCN\4400C-1c_PHASE_3_OV.dgn
 9/3/2019

REFER TO SHEETS TMP-73 THRU TMP-73A FOR CUT SECTION(S).

HNTB
 HNTB NORTH CAROLINA, P.C.
 343 E. Six Forks Road, Suite 200
 Raleigh, North Carolina 27609
 NC License No: C-1554

APPROVED: *Rhonda B. Early*
 DATE: 9/3/2019

DocuSigned by:
 Rhonda B. Early
 FMCAFSAC08F48A

NORTH CAROLINA
 PROFESSIONAL
 SEAL
 023521
 ENGINEER
 RHONDA B. EARLY

**DOCUMENT NOT CONSIDERED FINAL
 UNLESS ALL SIGNATURES COMPLETED**

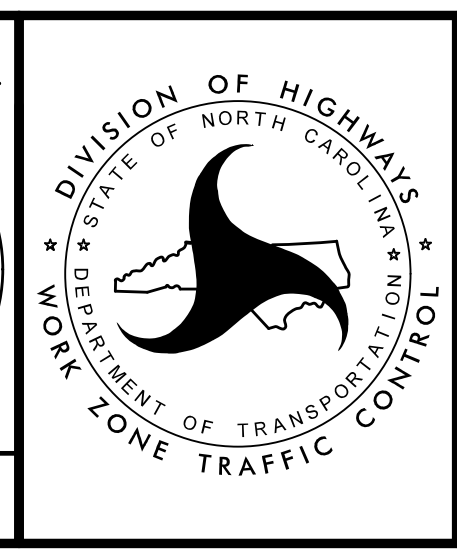

TRANSPORTATION
 MANAGEMENT PLAN

**PHASE III
 OVERVIEW**

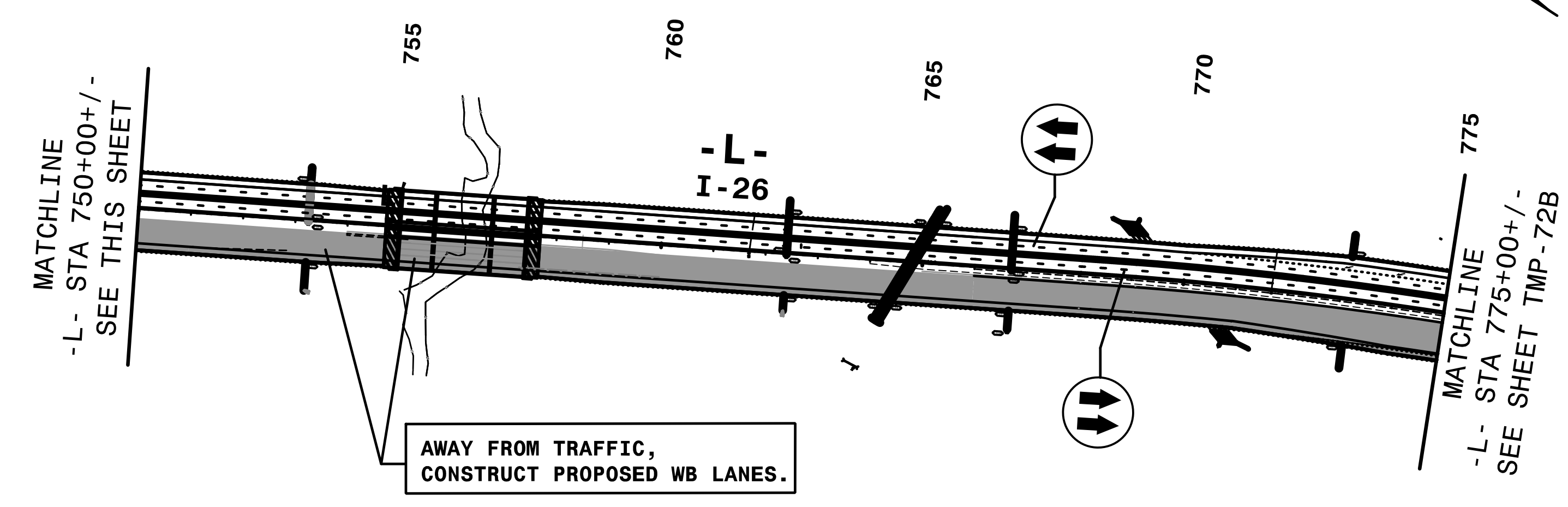
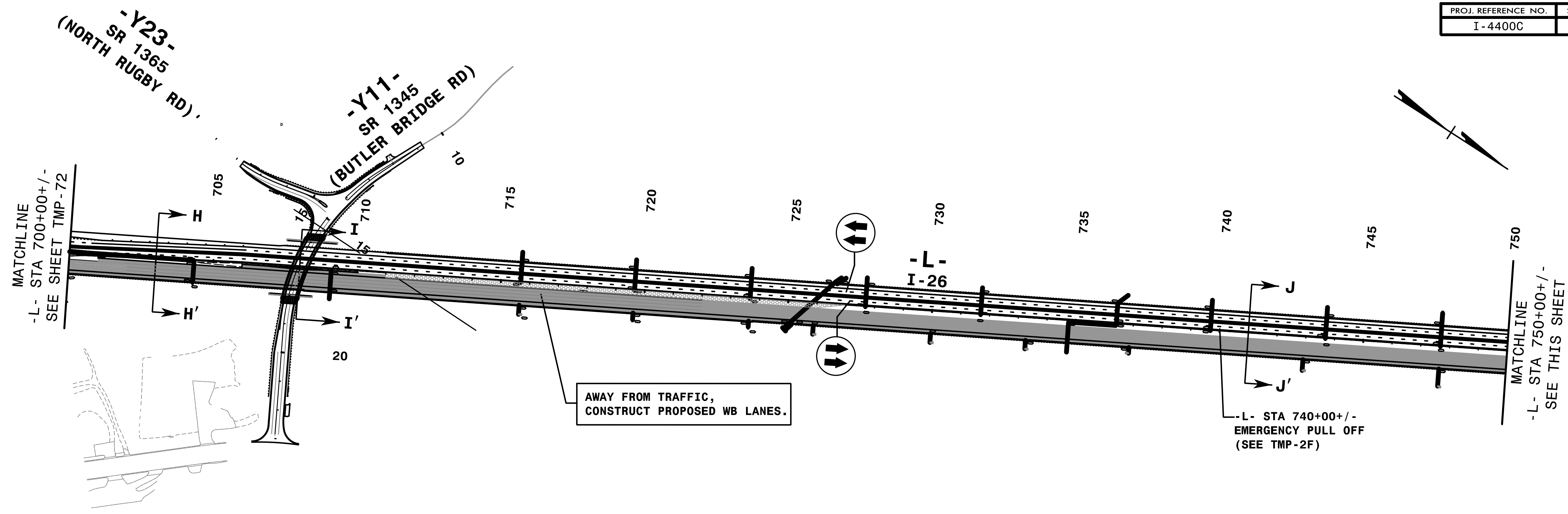

REFER TO SHEETS TMP-71 THRU TMP-73A FOR CUT SECTION(S).

HNTB
 HNTB NORTH CAROLINA, P.C.
 343 E. SIX FORKS ROAD, SUITE 200
 RALEIGH, NORTH CAROLINA 27609
 NC LICENSE NO: C-1554

DocuSigned by:
Rhonda B. Early
 F5MC4FSA08BF48A
 DATE: 9/3/2019

PROFESSIONAL ENGINEER
 NORTH CAROLINA
 SEAL
 023521
 RHONDA B. EARLY

**DOCUMENT NOT CONSIDERED FINAL
 UNLESS ALL SIGNATURES COMPLETED**



TRANSPORTATION
 MANAGEMENT PLAN

PHASE III
 OVERVIEW

3:33:43 PM
 \\TCN\4400C-1c_PHASE_3_0V.dgn
 9/3/2019

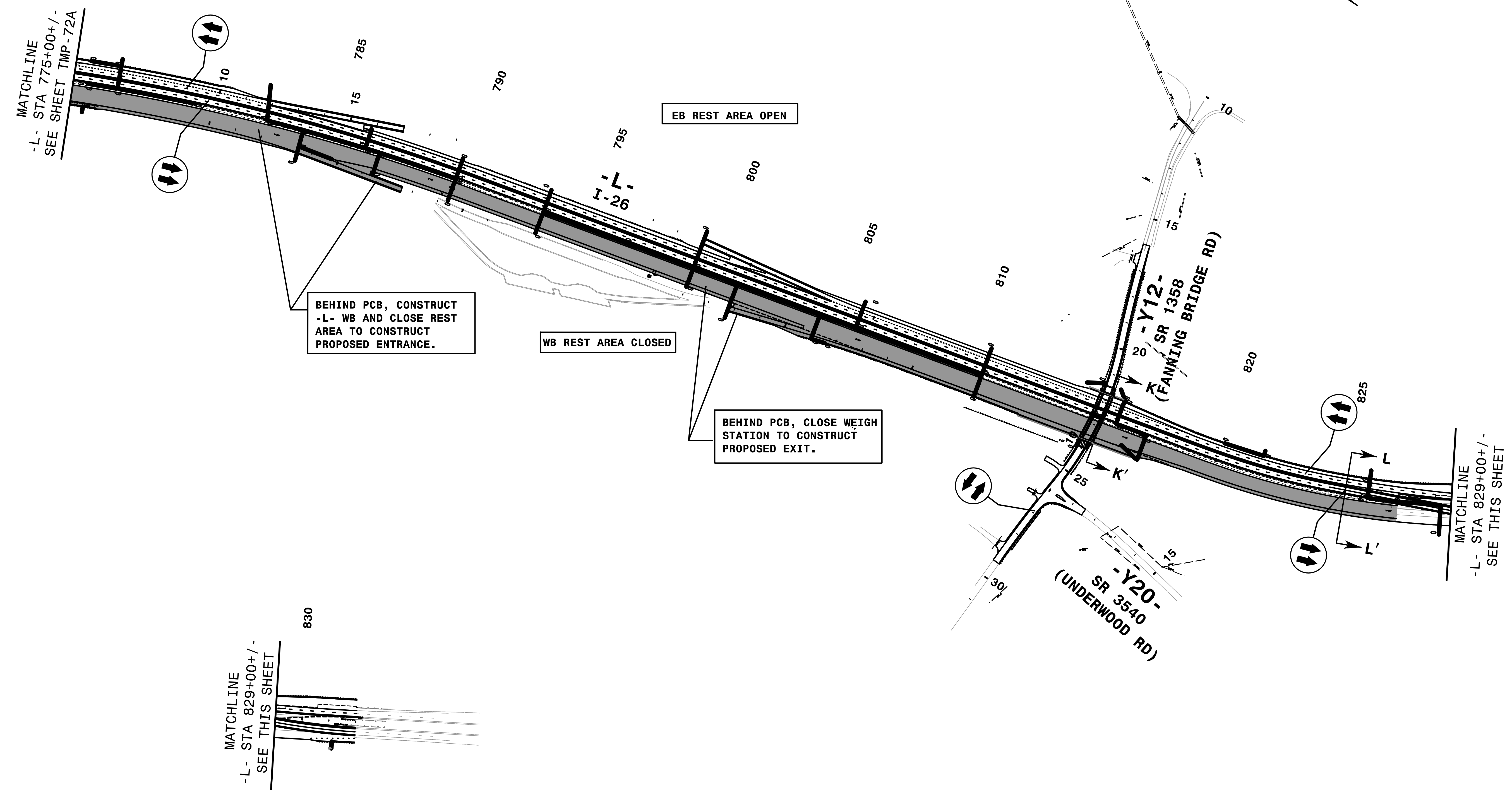

REFER TO SHEET TMP-73A FOR CUT SECTION(S).

3:33:55 PM
\\TCN\4400C-1c_PHASE 3_OV.dgn
9/3/2019

HNTB
 HNTB NORTH CAROLINA, P.C.
 343 E. Six Forks Road, Suite 200
 Raleigh, North Carolina 27609
 NC License No: C-1554

APPROVED: *Rhonda B. Early*
DocuSigned by:
Rhonda B. Early
F5MC4FSA08BF48A

DATE: 9/3/2019

NORTH CAROLINA
 PROFESSIONAL
 SEAL
 023521
 ENGINEER
 RHONDA B. EARLY

**DOCUMENT NOT CONSIDERED FINAL
 UNLESS ALL SIGNATURES COMPLETED**

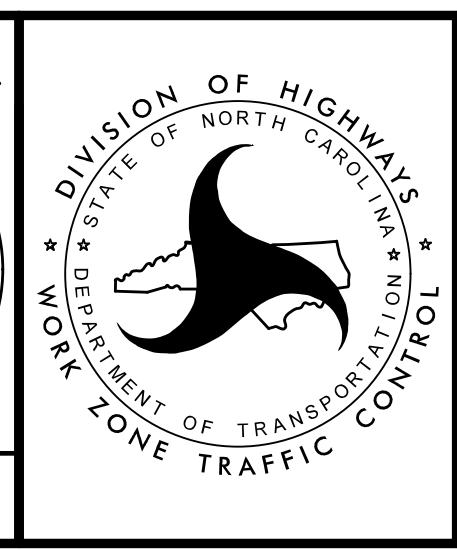

TRANSPORTATION
 MANAGEMENT PLAN

PHASE III
 OVERVIEW

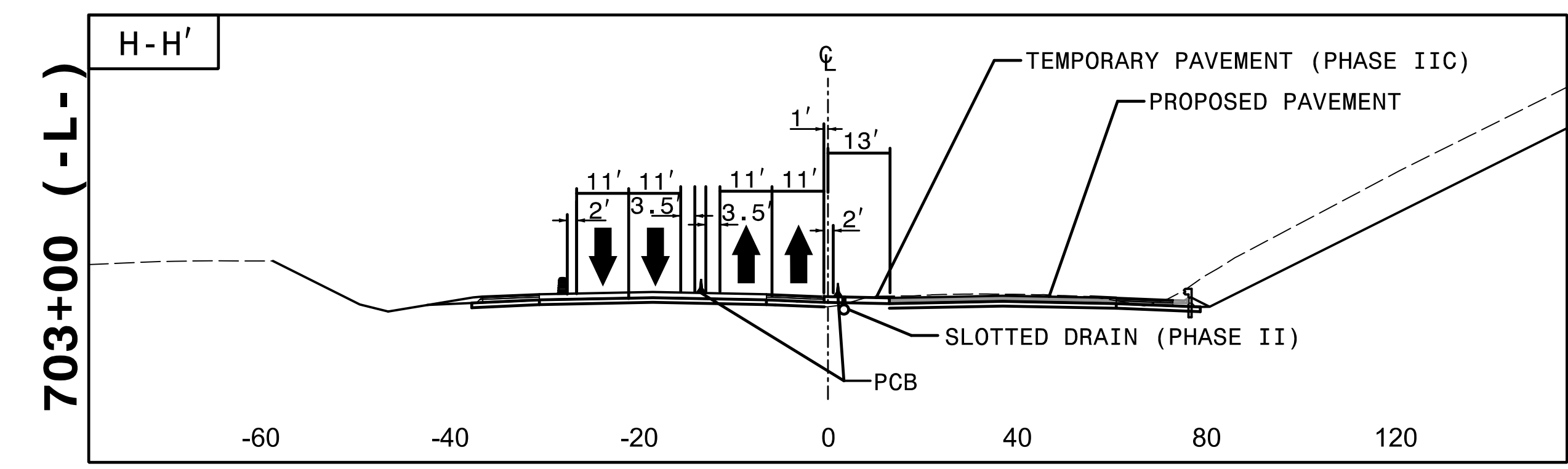
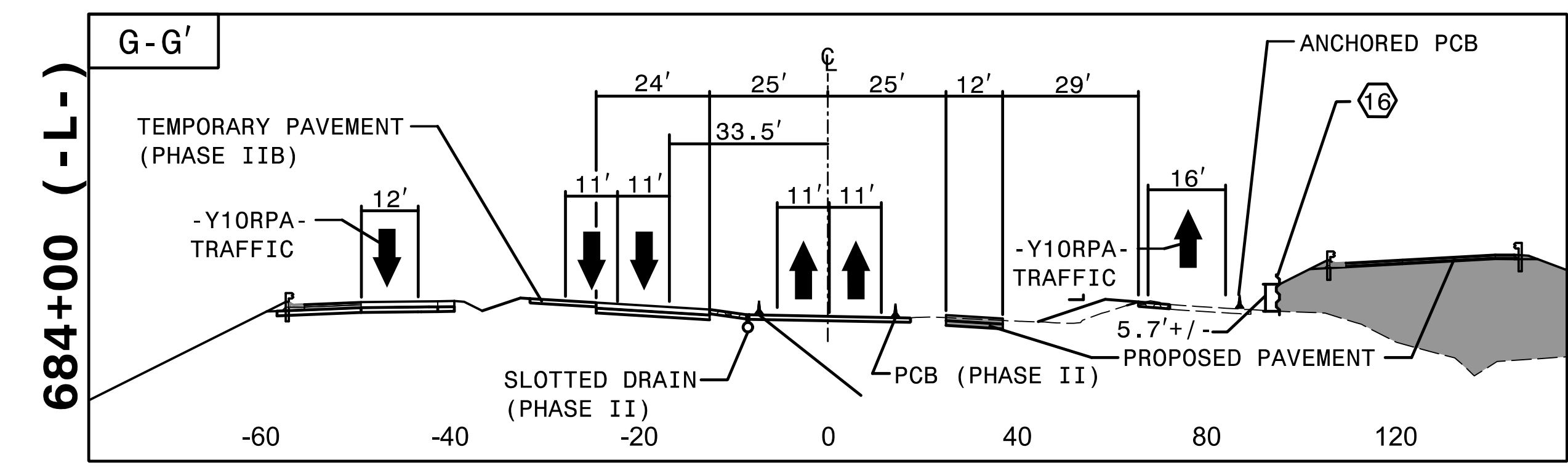
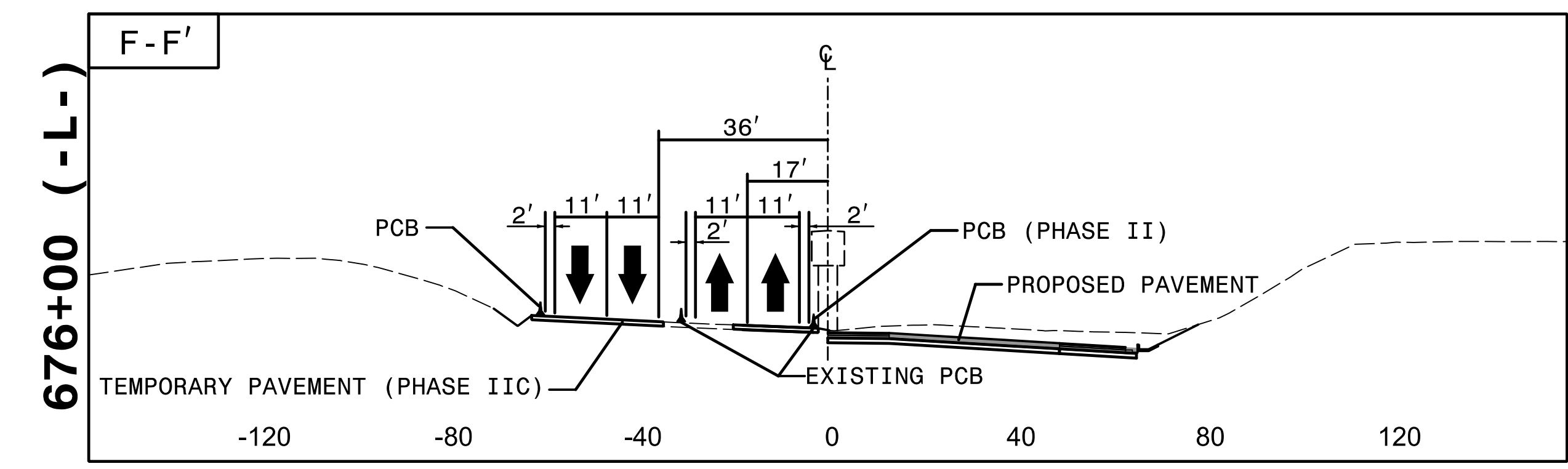
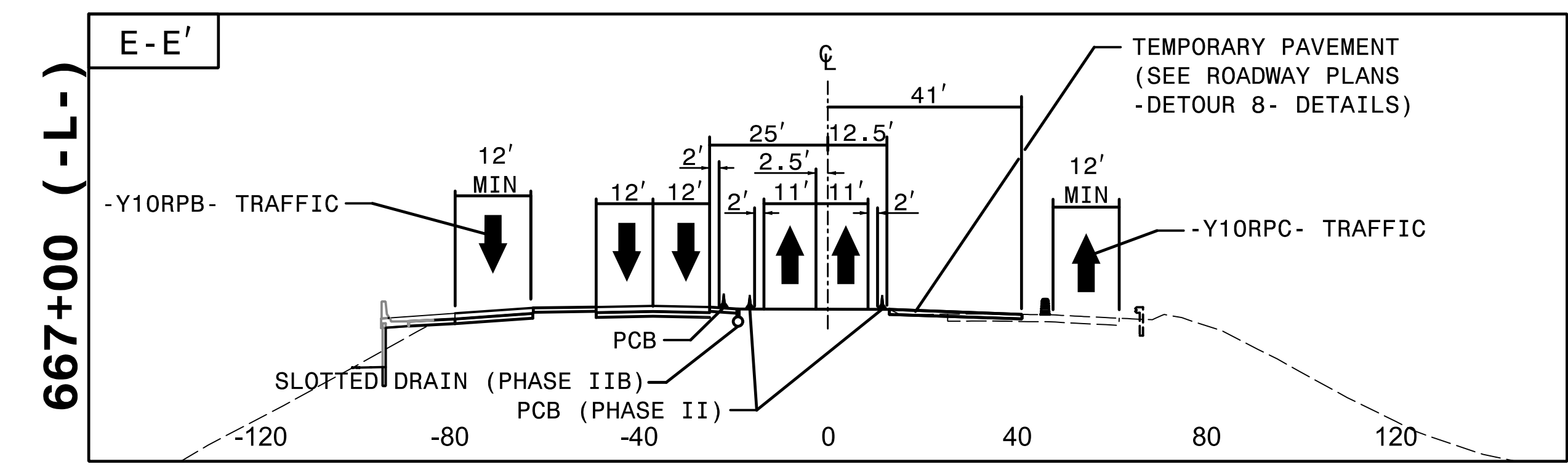
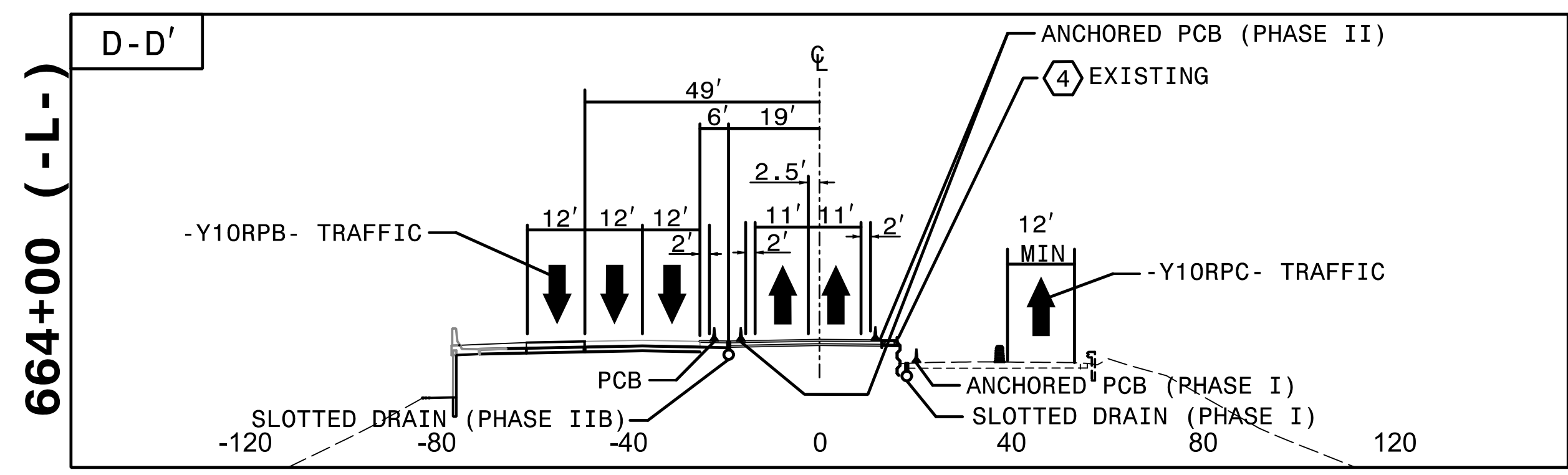
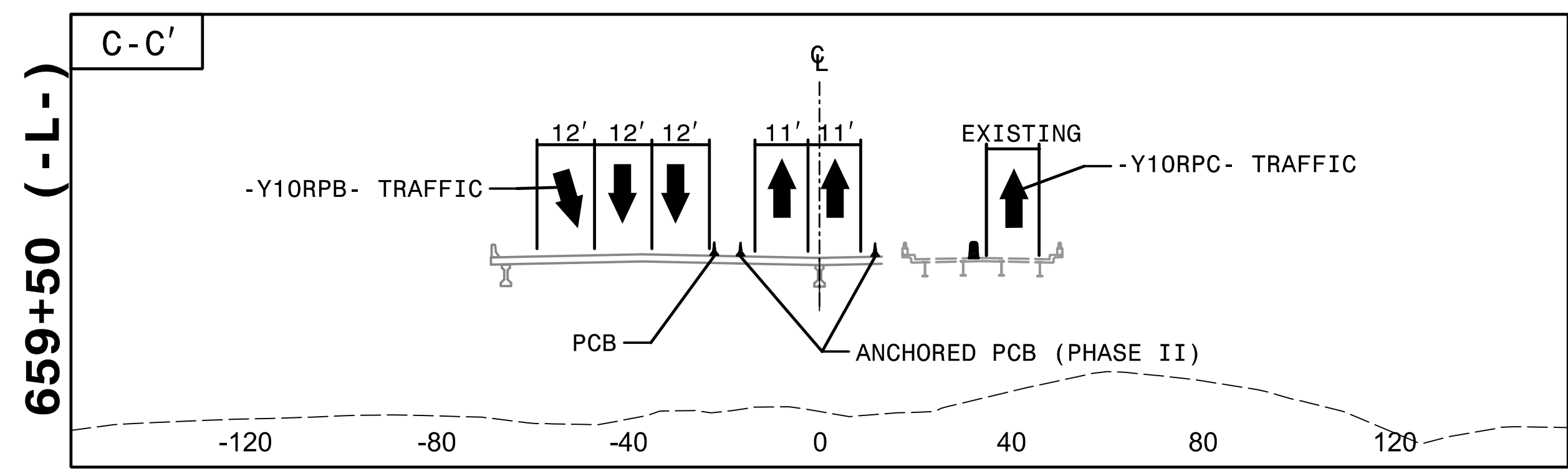
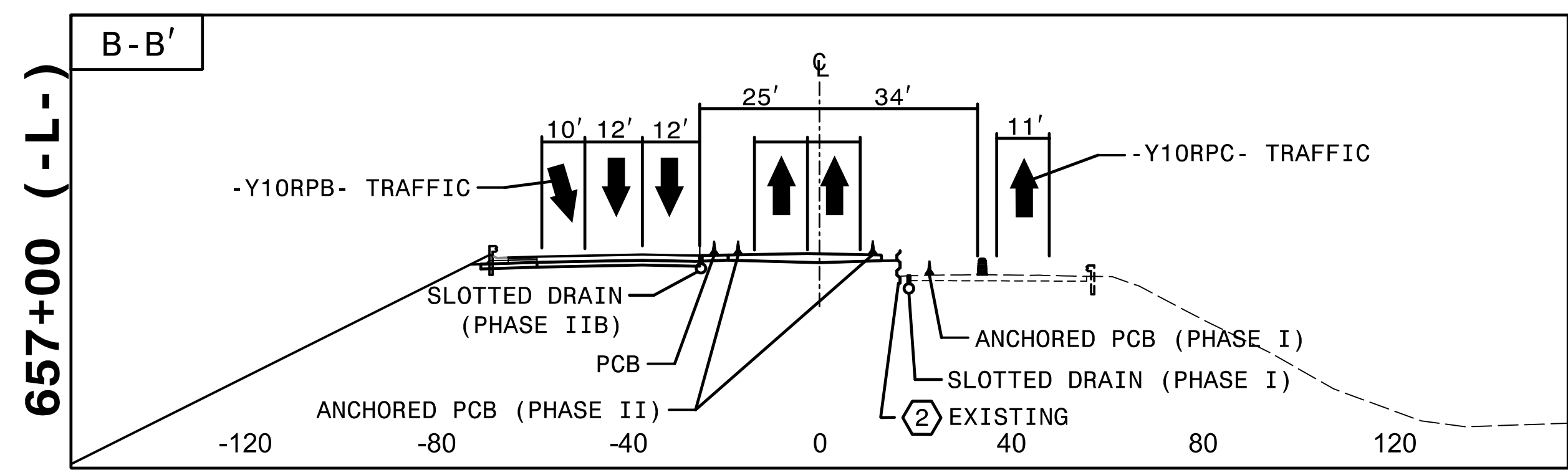
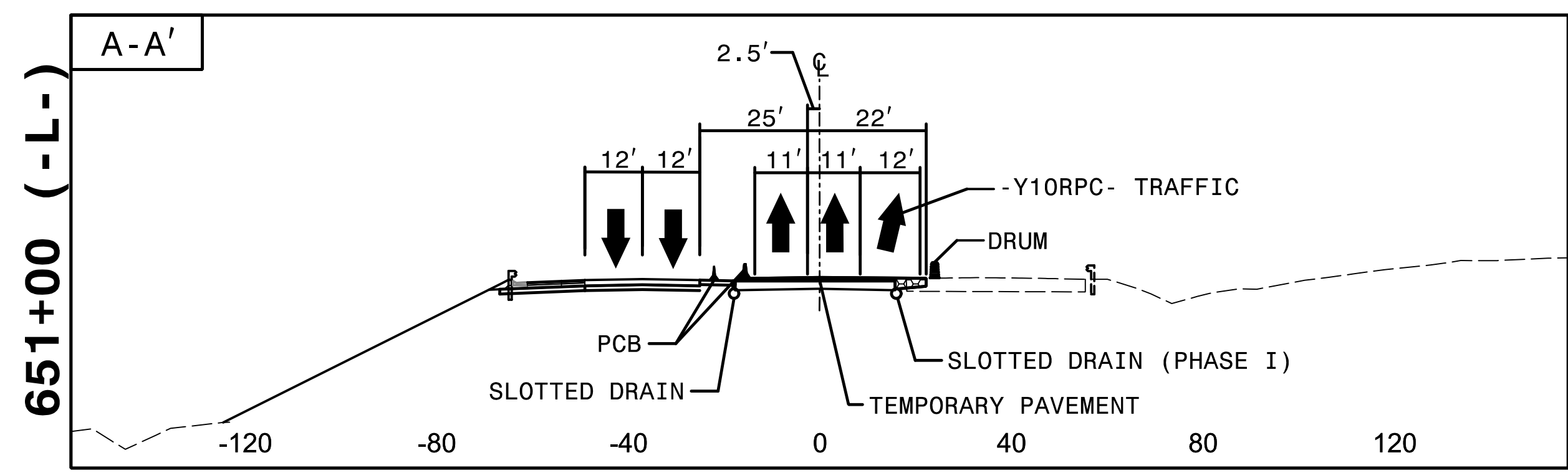

3:34:48 PM
I:\CP\4400C-TC-P3 CUTS.dgn
9/3/2019



APPROVED: *Rhonda B. Early*
 DATE: 9/3/2019

DOCUMENT NOT CONSIDERED FINAL
UNLESS ALL SIGNATURES COMPLETED

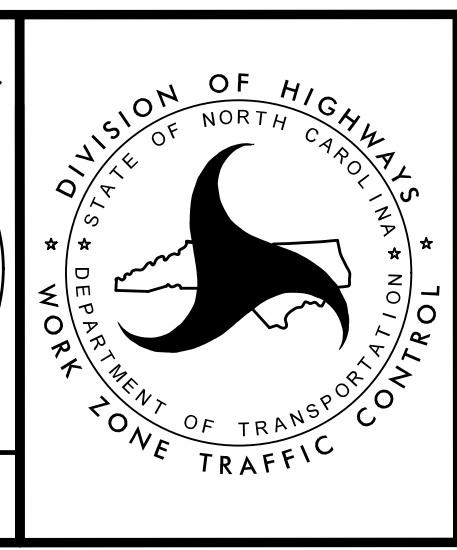

TRANSPORTATION
MANAGEMENT PLAN

PHASE III
CUT SECTIONS

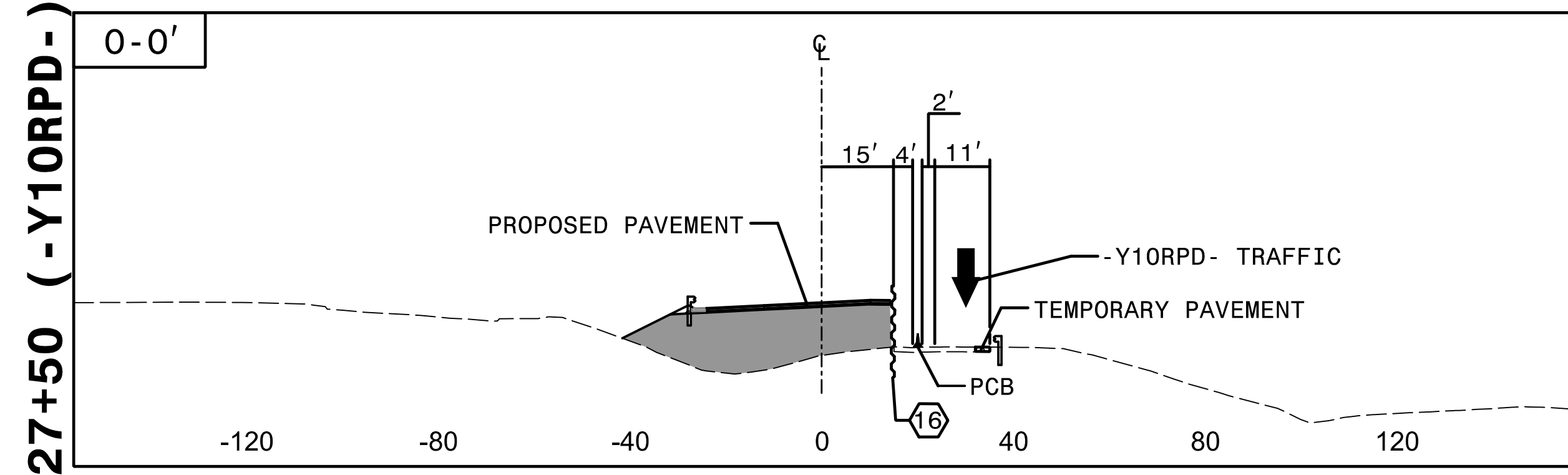
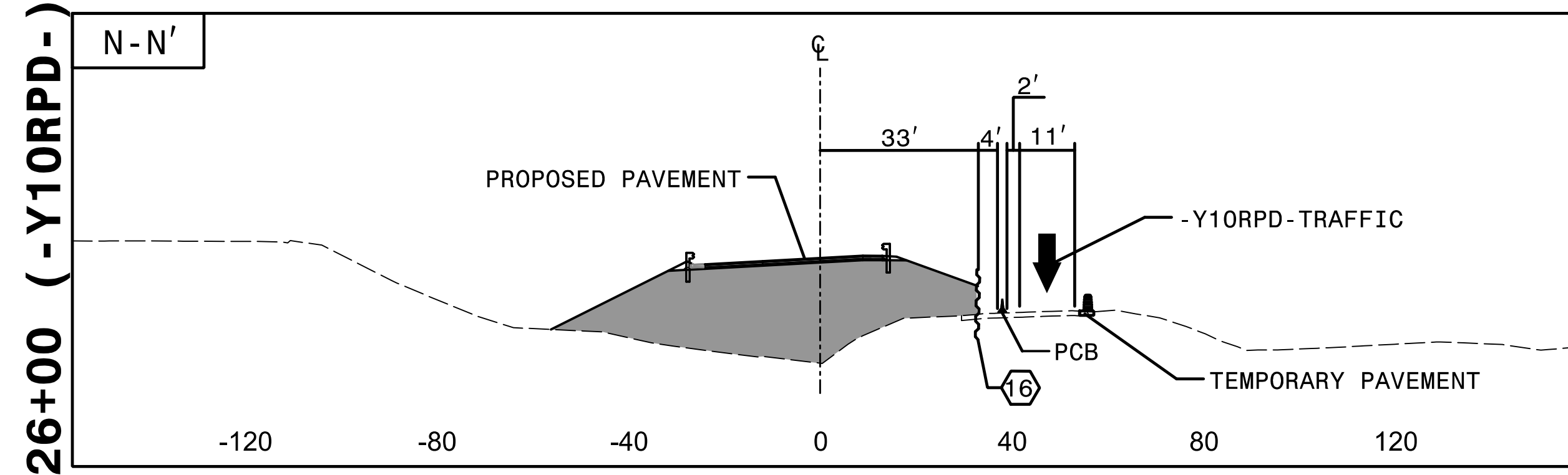
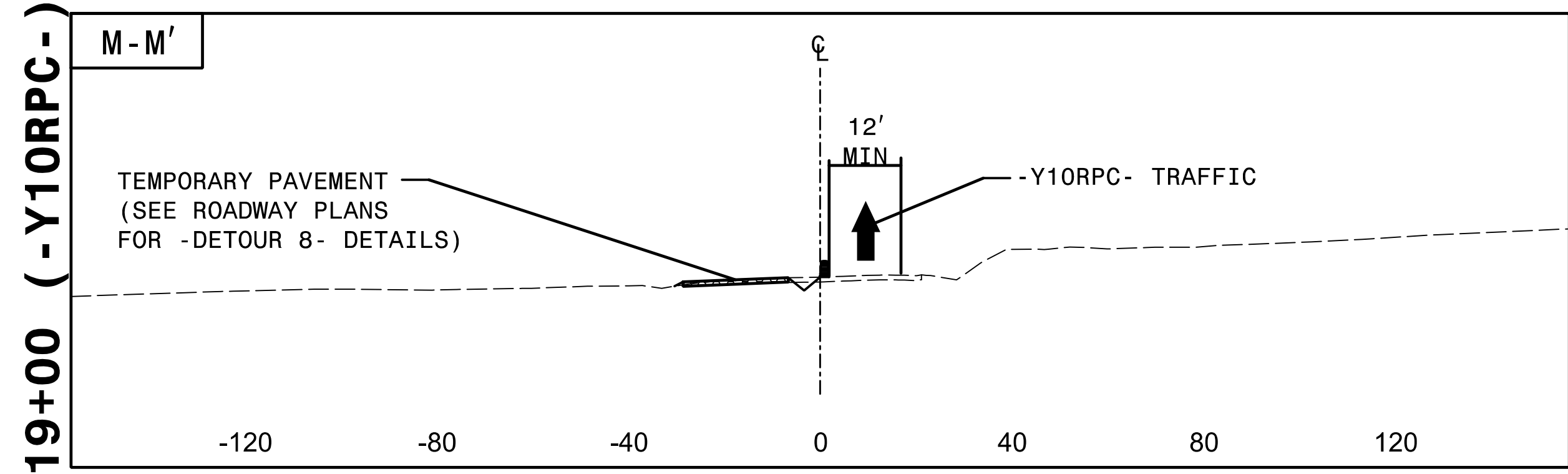
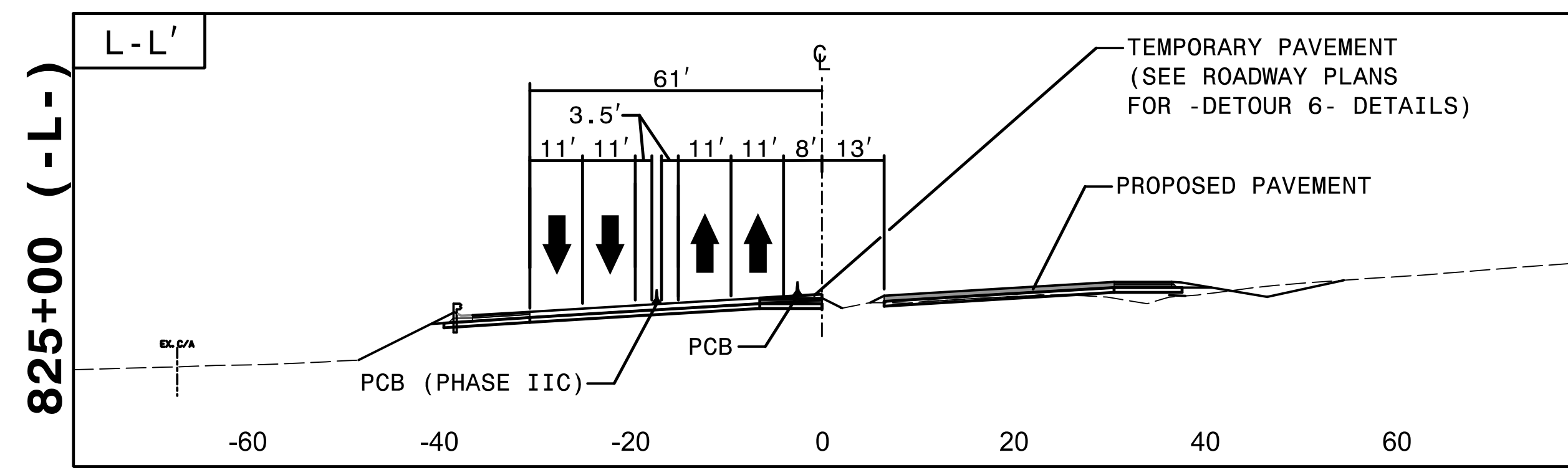
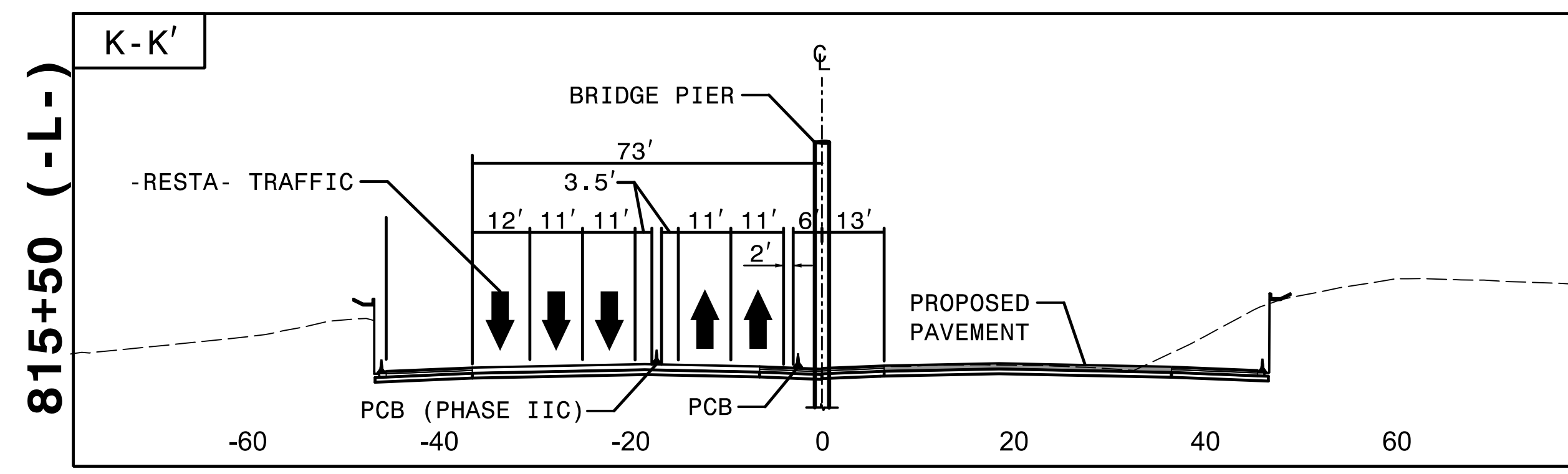
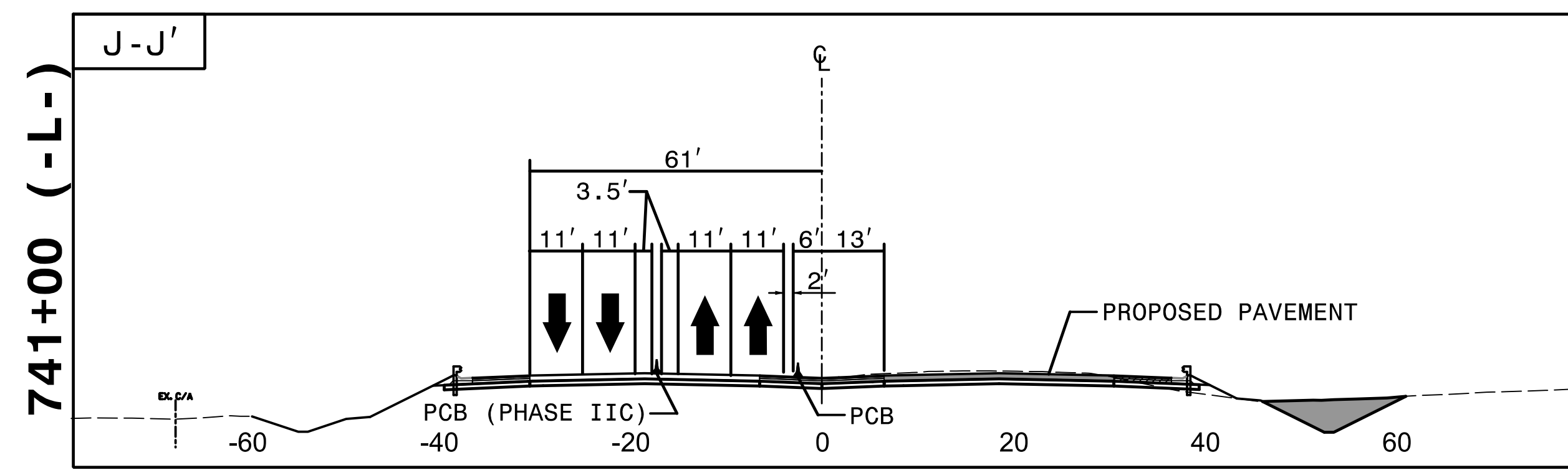
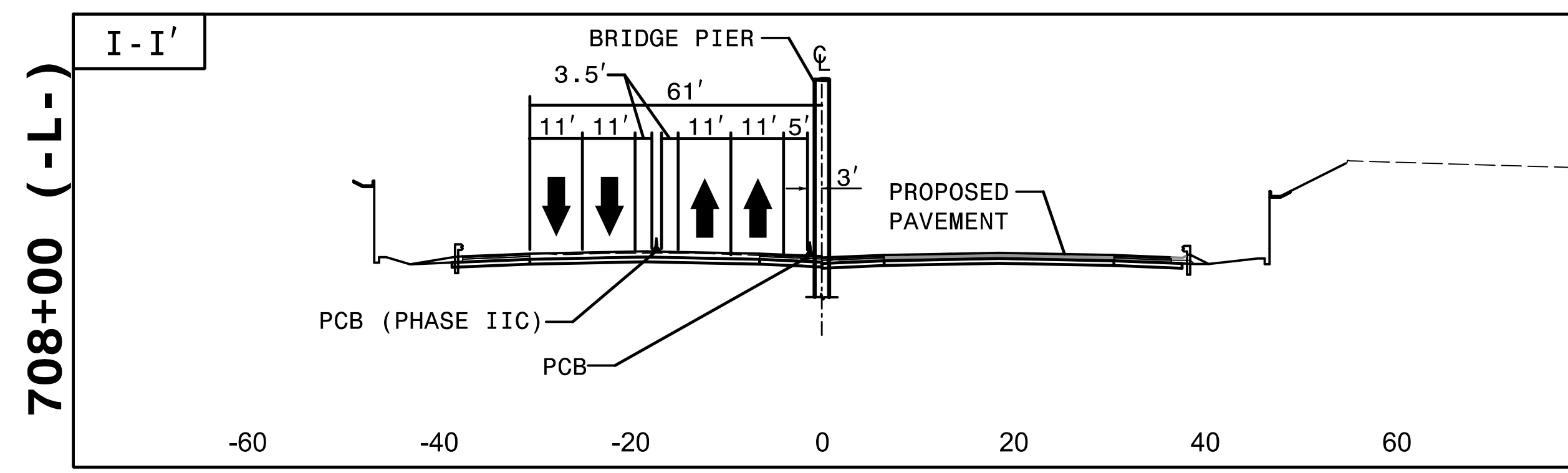

3:35:16 PM
3:\TCN\4400C_Tc_P3 CUTS.dgn
9/3/2019

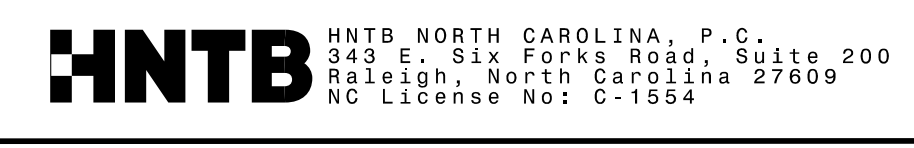

HNTB NORTH CAROLINA, P.C.
343 E. Six Forks Road, Suite 200
Raleigh, North Carolina 27609
NC License No: C-1554

APPROVED: *Rhonda B. Early*
DATE: 9/3/2019

DocuSigned by:
Rhonda B. Early
F5ACAF5ACDBF4BA.

PROFESSIONAL ENGINEER
NORTH CAROLINA
SEAL
023521
RHONDA B. EARLY

DOCUMENT NOT CONSIDERED FINAL
UNLESS ALL SIGNATURES COMPLETED

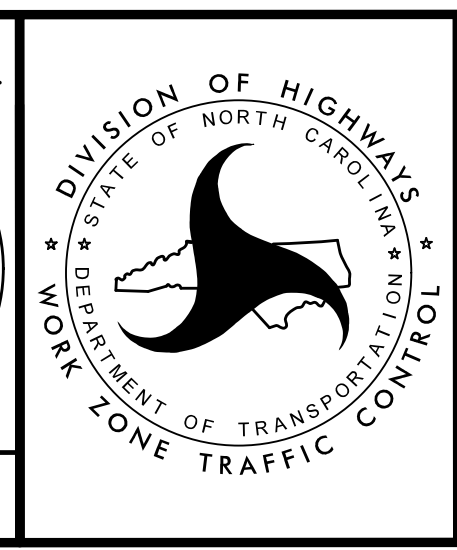

TRANSPORTATION
MANAGEMENT PLAN

PHASE III
CUT SECTIONS

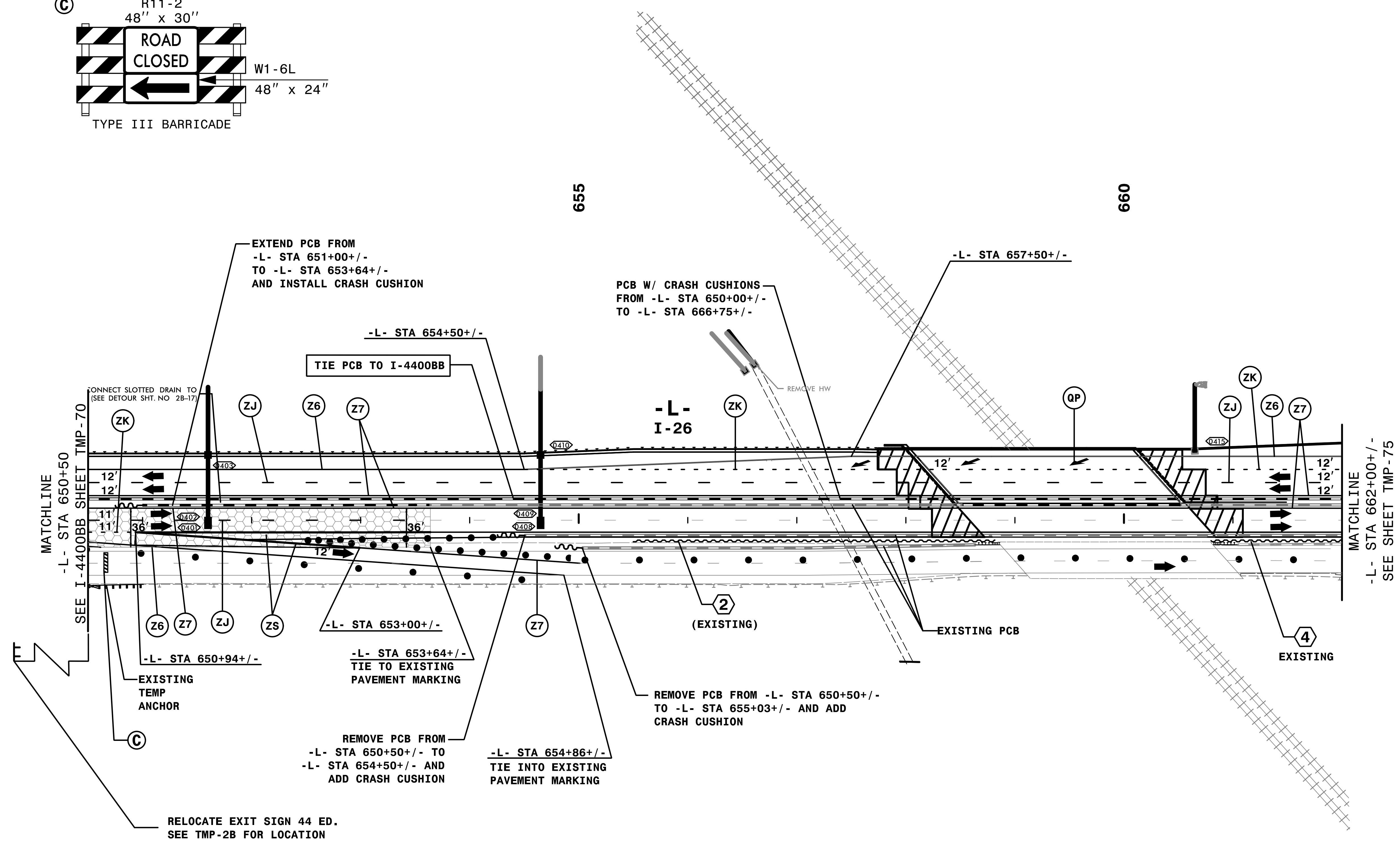
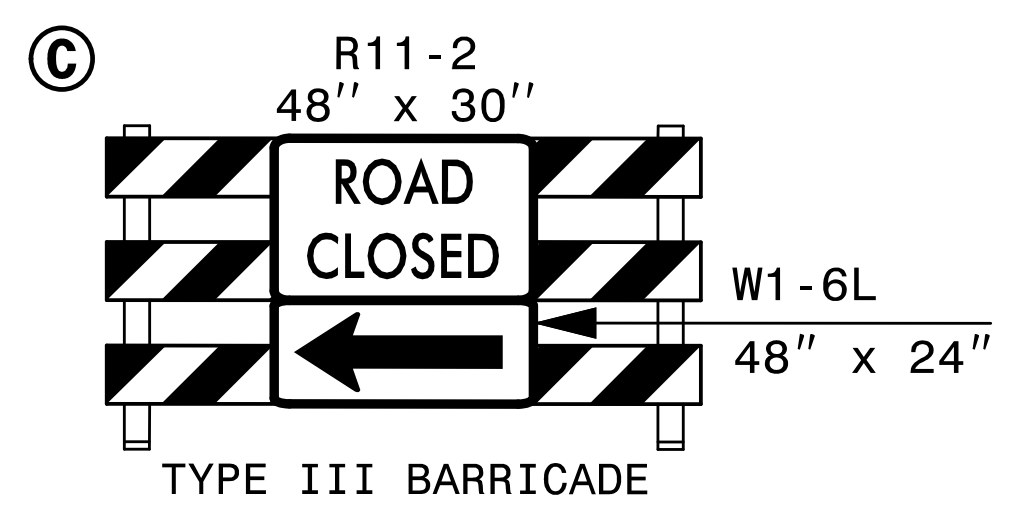

REMOVE CONFLICTING PAVEMENT MARKING.

3:35:39 PM
 \\TCN\4400C-TC-ALP3\di.dgn
 9/3/2019

HNTB
 HNTB NORTH CAROLINA, P.C.
 343 E. Six Forks Road, Suite 200
 Raleigh, North Carolina 27609
 NC License No: C-1554

DocuSigned by:
Rhonda B. Early
 F5MC4F5A0CBF48A
 APPROVED: _____
 DATE: 9/3/2019

NORTH CAROLINA
 PROFESSIONAL
 SEAL
 023521
 ENGINEER
RHONDA B. EARLY

DOCUMENT NOT CONSIDERED FINAL
 UNLESS ALL SIGNATURES COMPLETED

TRANSPORTATION
 MANAGEMENT PLAN

PHASE III
 DETAIL

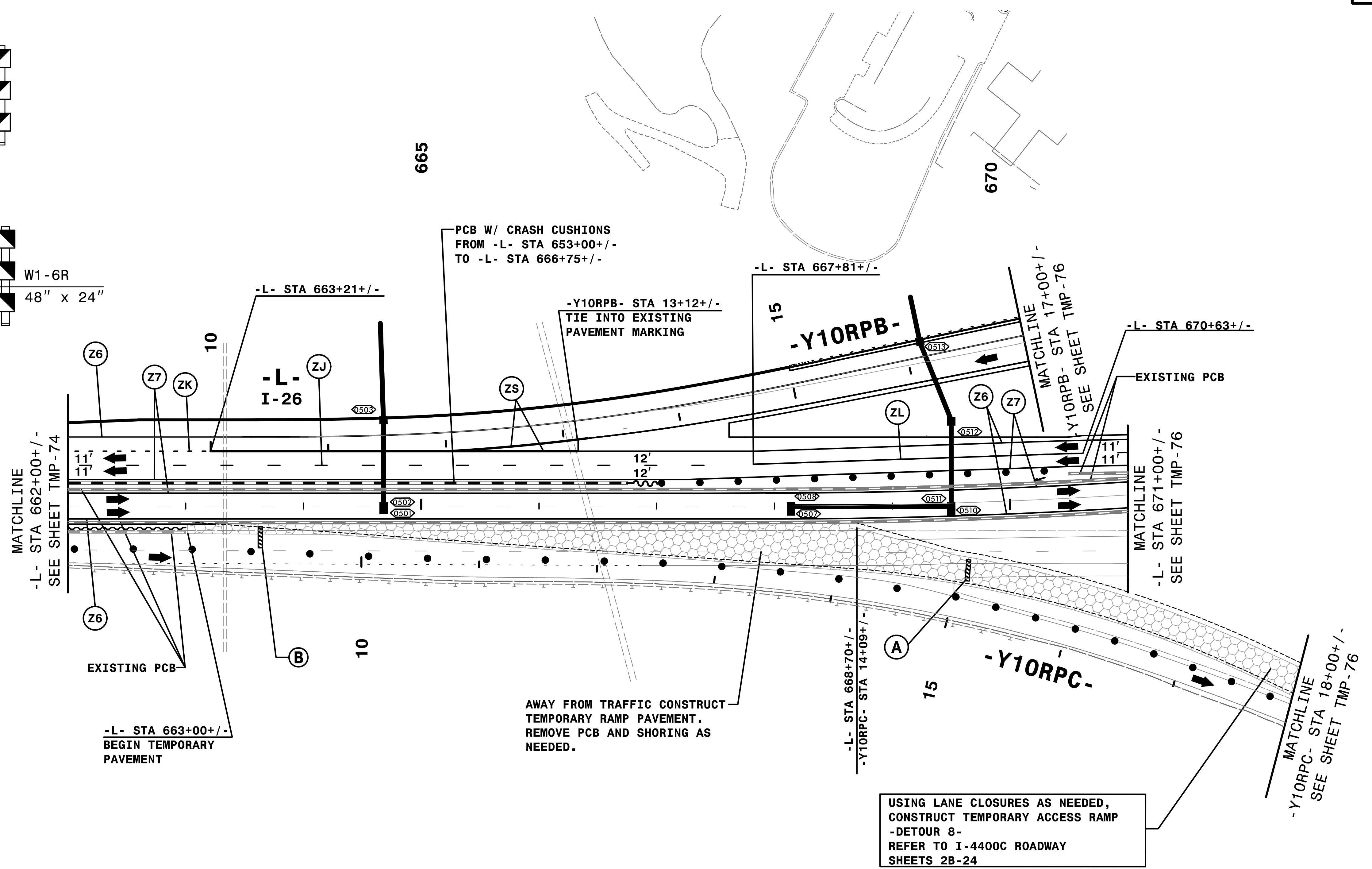
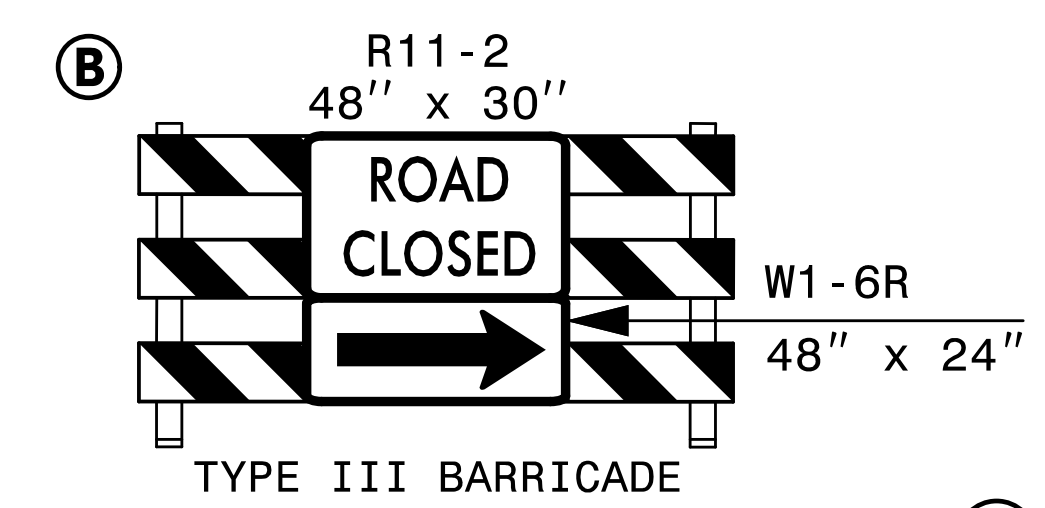
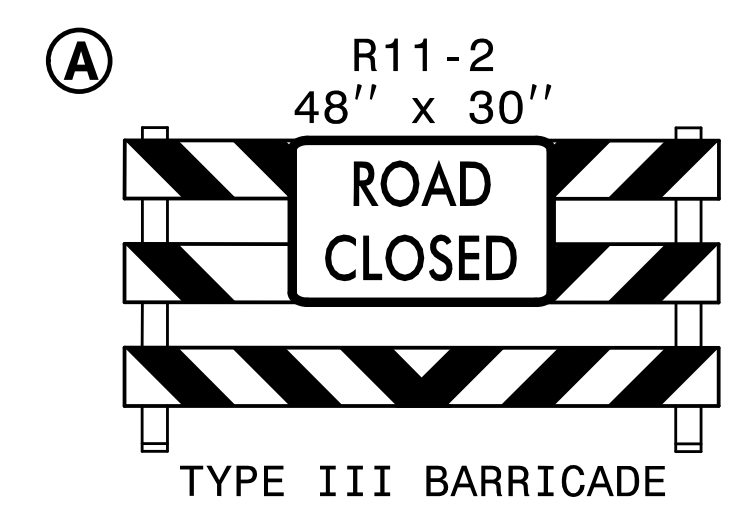

3:35:54 PM
\\TCN\4400C-TC-ALP3d2.dgn
9/3/2019

REMOVE CONFLICTING PAVEMENT MARKING.

HNTB
HNTB NORTH CAROLINA, P.C.
343 E. Six Forks Road, Suite 200
Raleigh, North Carolina 27609
NC License No: C-1554

APPROVED: *Rhonda B. Early*
DATE: 9/3/2019

DocuSigned by:
Rhonda B. Early
F5MC4FSA08F48A

9/3/2019

PROFESSIONAL ENGINEER SEAL
NORTH CAROLINA
023521
RHONDA B. EARLY

DOCUMENT NOT CONSIDERED FINAL UNLESS ALL SIGNATURES COMPLETED



TRANSPORTATION
MANAGEMENT PLAN

PHASE III
DETAIL

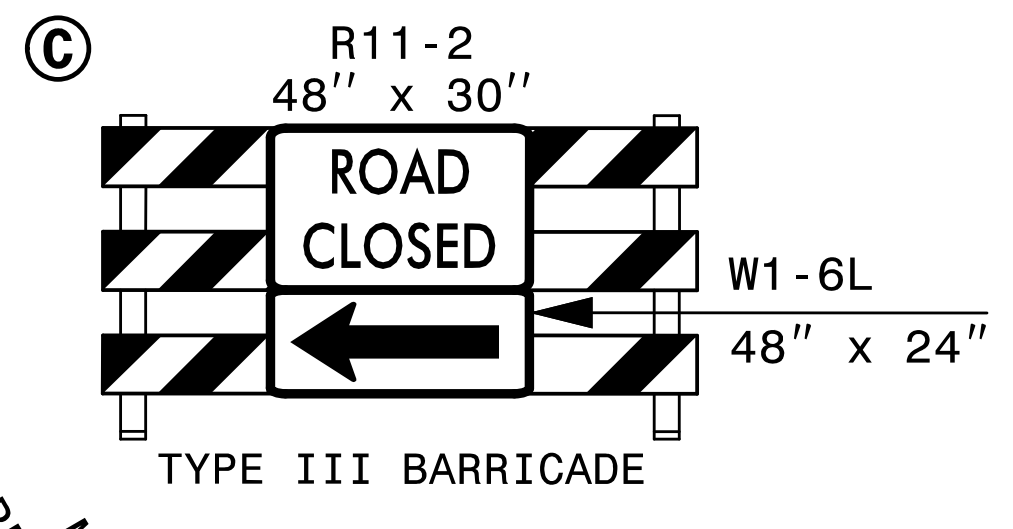
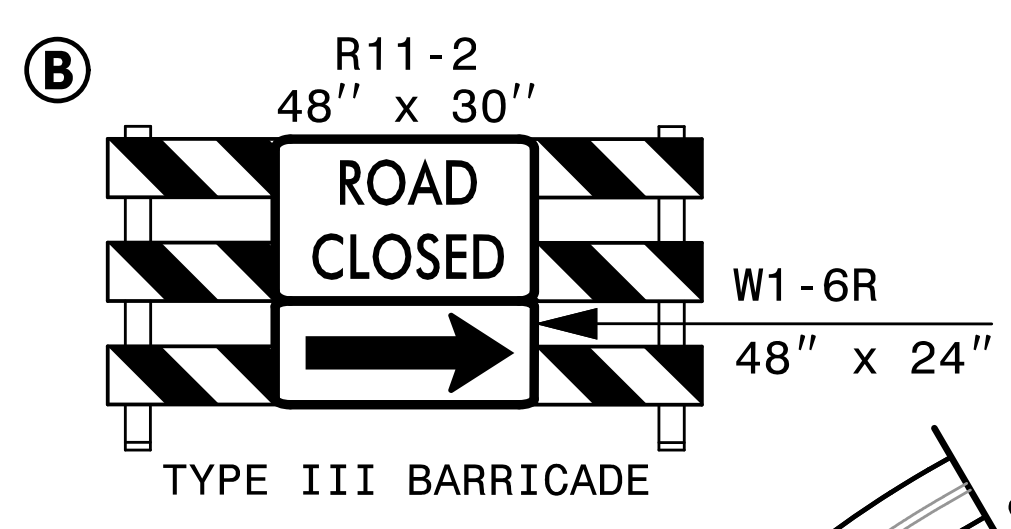
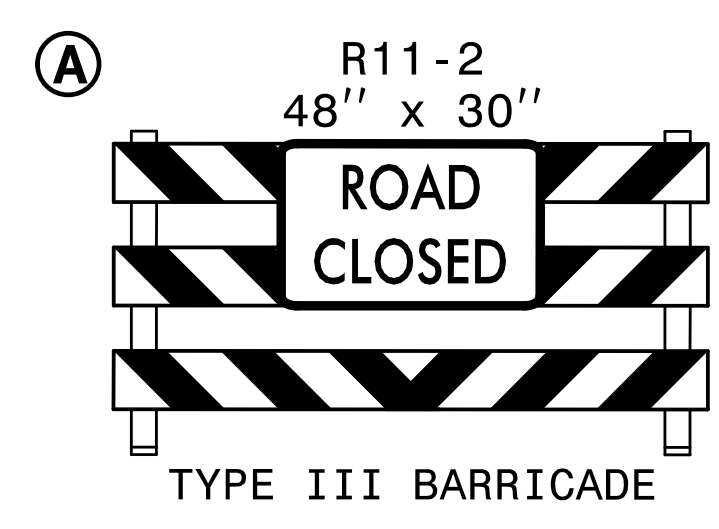

BEHIND PCB, CONSTRUCT PROPOSED -Y10RPD- RAMP FROM -Y10RPD- STA 10+00+/- TO -Y10RPD- STA 29+17+/-.

PCB W/ CRASH CUSHIONS FROM -Y10RPD- STA 24+75+/- TO -Y10RPD- STA 28+76+/-.

USING DRUMS TO NARROW LANE, CONSTRUCT TEMPORARY WIDENING -Y10RPD- STA 24+65+/- TO -Y10RPD- STA 29+54+/- . REMOVE AND RESET GUARDRAIL.

-Y10RPD SPUR LT- STA 10+00+/- = -Y10RPD- STA 28+92+/-

-Y10RPD SPUR LT- STA 10+28+/-

-Y10RPD SPUR LT- STA 10+34+/- 2.5' WIDENING

-Y10RPD SPUR LT- STA 10+94+/-

-Y10RPD SPUR LT- STA 10+94+/-

-Y10RPD SPUR LT- STA 10+94+/-

-Y10RPD SPUR LT- STA 10+94+/-

-Y10RPD SPUR LT- STA 10+94+/-

-Y10RPD SPUR LT- STA 10+94+/-

-Y10RPD SPUR LT- STA 10+94+/-

-Y10RPD SPUR LT- STA 10+94+/-

-Y10RPD SPUR LT- STA 10+94+/-

-Y10RPD SPUR LT- STA 10+94+/-

-Y10RPD SPUR LT- STA 10+94+/-

-Y10RPD SPUR LT- STA 10+94+/-

-Y10RPD SPUR LT- STA 10+94+/-

-Y10RPD SPUR LT- STA 10+94+/-

-Y10RPD SPUR LT- STA 10+94+/-

-Y10RPD SPUR LT- STA 10+94+/-

-Y10RPD SPUR LT- STA 10+94+/-

-Y10RPD SPUR LT- STA 10+94+/-

-Y10RPD SPUR LT- STA 10+94+/-

-Y10RPD SPUR LT- STA 10+94+/-

-Y10RPD SPUR LT- STA 10+94+/-

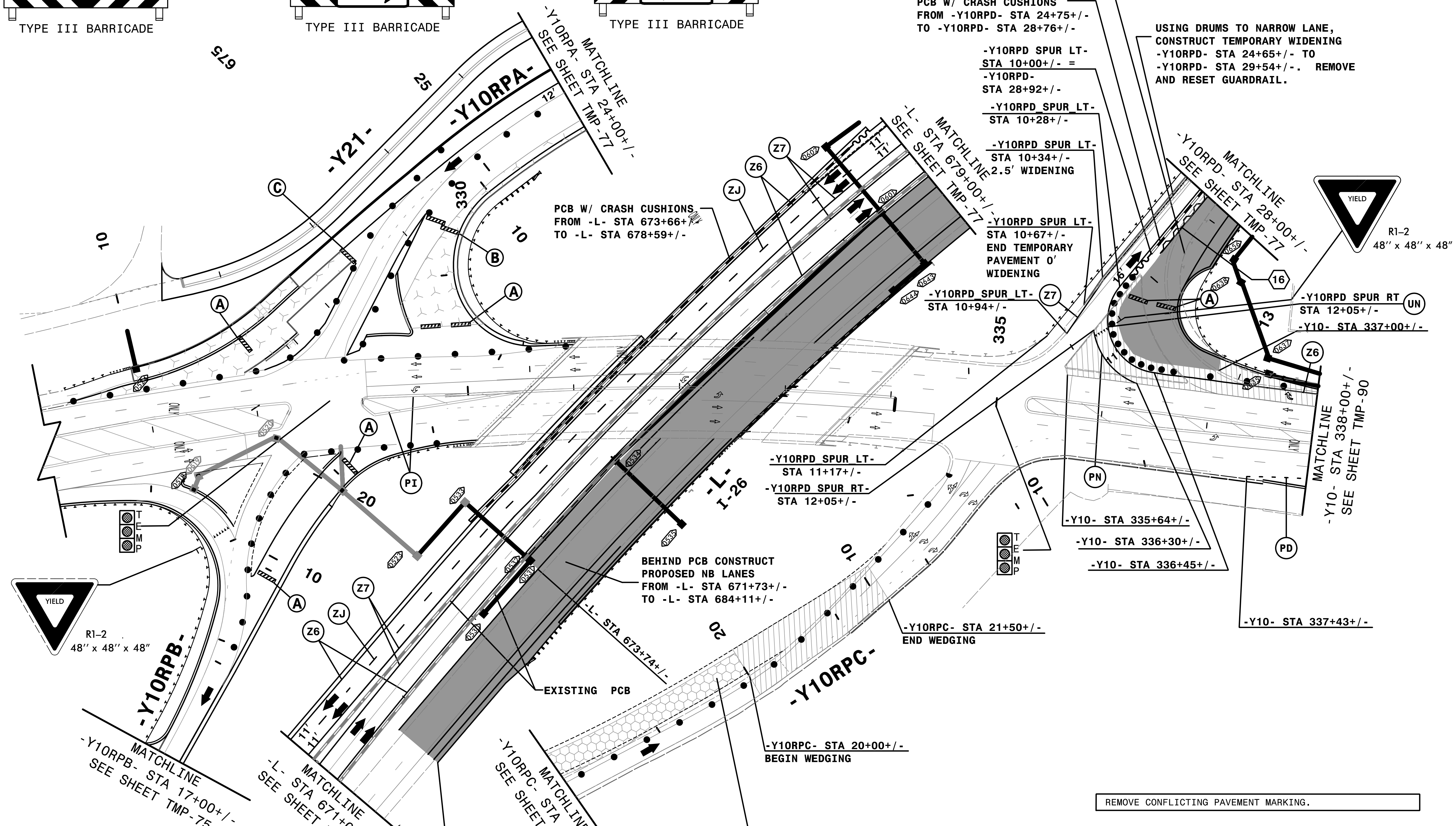

16 EST QUANTITY = 2525 SF
TEMPORARY SHORING
FROM -Y10RPD- STA 24+75+/-, 45' RT
TO -Y10RPD- STA 26+00+/-, 33.5' RT
TO -Y10RPD- STA 27+00+/-, 18.6' RT
TO -Y10RPD- STA 28+70+/-, 9.7' RT
(SEE SHEET TMP-2A.2 FOR TEMPORARY SHORING NOTES)

USING LANE CLOSURES AS NEEDED, CONSTRUCT TEMPORARY ACCESS RAMP -DETOUR 8- REFER TO I-4400C ROADWAY SHEETS 2B-24

REMOVE CONFLICTING PAVEMENT MARKING.

APPROVED: Rhonda B. Early
DATE: 9/3/2019
NORTH CAROLINA PROFESSIONAL ENGINEER SEAL 023521
RHONDA B. EARLY
DOCUMENT NOT CONSIDERED FINAL UNLESS ALL SIGNATURES COMPLETED

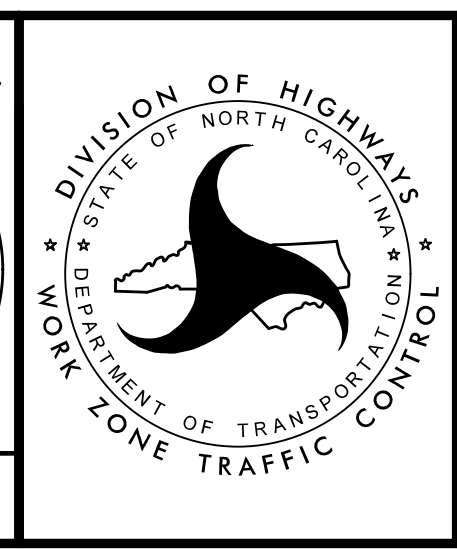

TRANSPORTATION MANAGEMENT PLAN
PHASE III
DETAIL

HNTB
HNTB NORTH CAROLINA, P.C.
343 E. Six Forks Road, Suite 200
Raleigh, North Carolina 27609
NC License No: C-1554

3:36:14 PM
I:\CP\14400C-1c_ALP3d3.dgn
9/3/2019

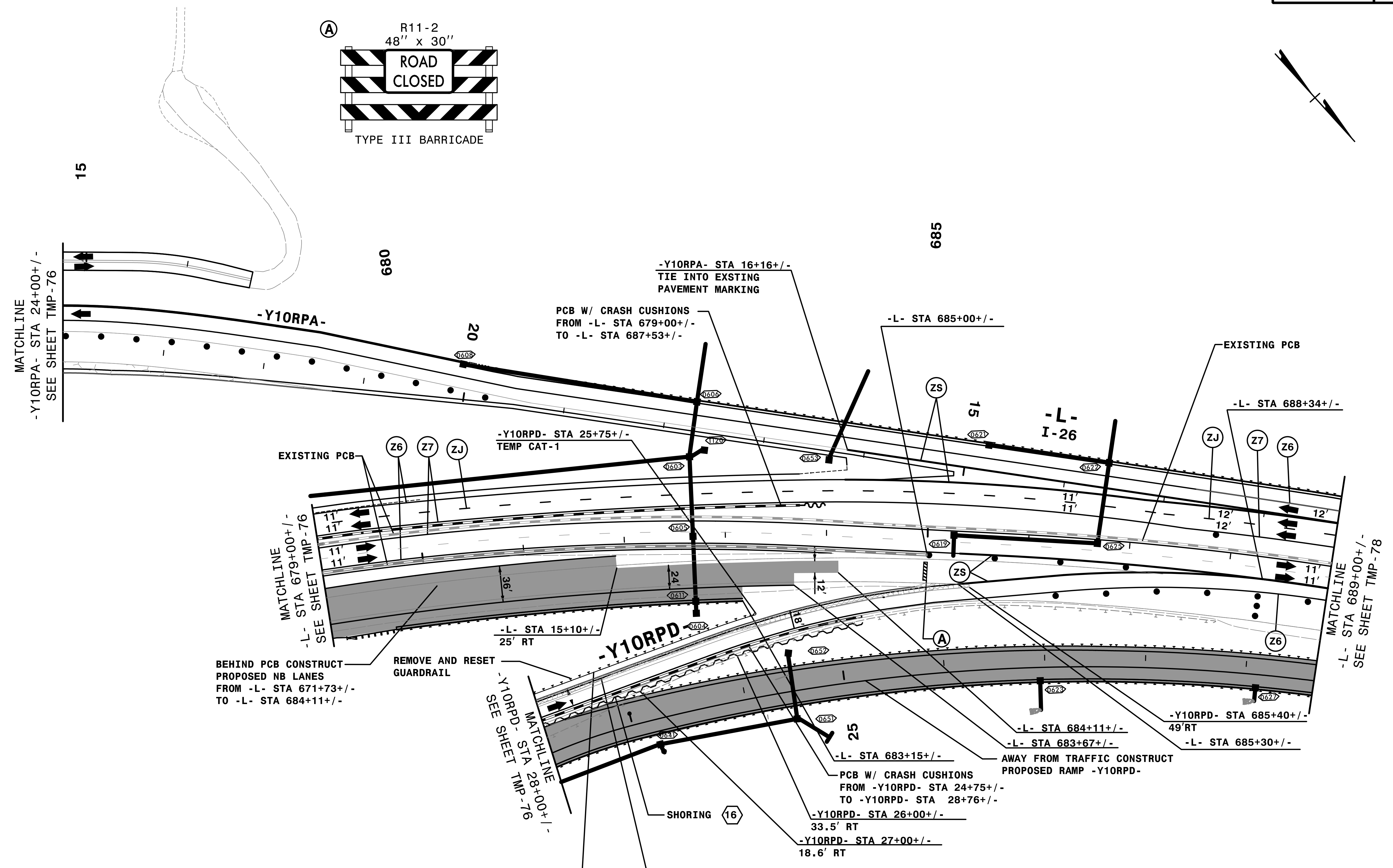
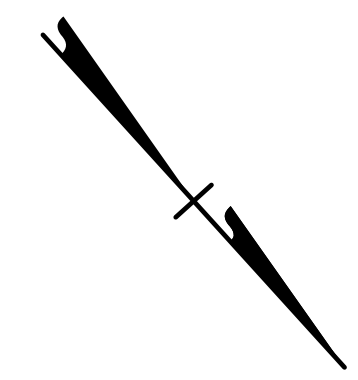
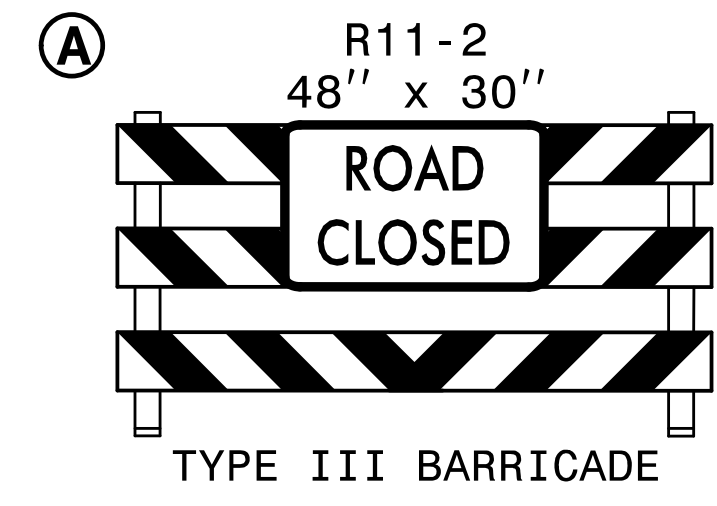

SHORING (16) EST QUANTITY = 2525 SF

TEMPORARY SHORING
FROM -Y10RPA- STA 24+75+/-, 45' RT
TO -Y10RPD- STA 26+00+/-, 33.5' RT
TO -Y10RPD- STA 27+00+/-, 18.6' RT
TO -Y10RPD- STA 28+70+/-, 9.7' RT

(SEE SHEET TMP-2A.2 FOR
TEMPORARY SHORING NOTES)

-Y10RPD- STA 27+38+/-
BEGIN TEMPORARY GUARDRAIL

-Y10RPD-
TEMPORARY PAVEMENT
FROM -L- STA 385+40+/-
TO -Y10RPD- STA 28+76+/-

HNTB
HNTB NORTH CAROLINA, P.C.
343 E. Six Forks Road, Suite 200
Raleigh, North Carolina 27609
NC License No: C-1554

DocuSigned by:
Rhonda B. Early
APPROVED: Rhonda B. Early
FMC#FAS08F48A
DATE: 9/3/2019

PROFESSIONAL
ENGINEER
R. B. EARLY
SEAL
023521
NORTH CAROLINA

DOCUMENT NOT CONSIDERED FINAL
UNLESS ALL SIGNATURES COMPLETED



TRANSPORTATION
MANAGEMENT PLAN

PHASE III
DETAIL

3:36:28 PM
\\TCN\4400C-TC_ALP3d4.dgn
9/3/2019

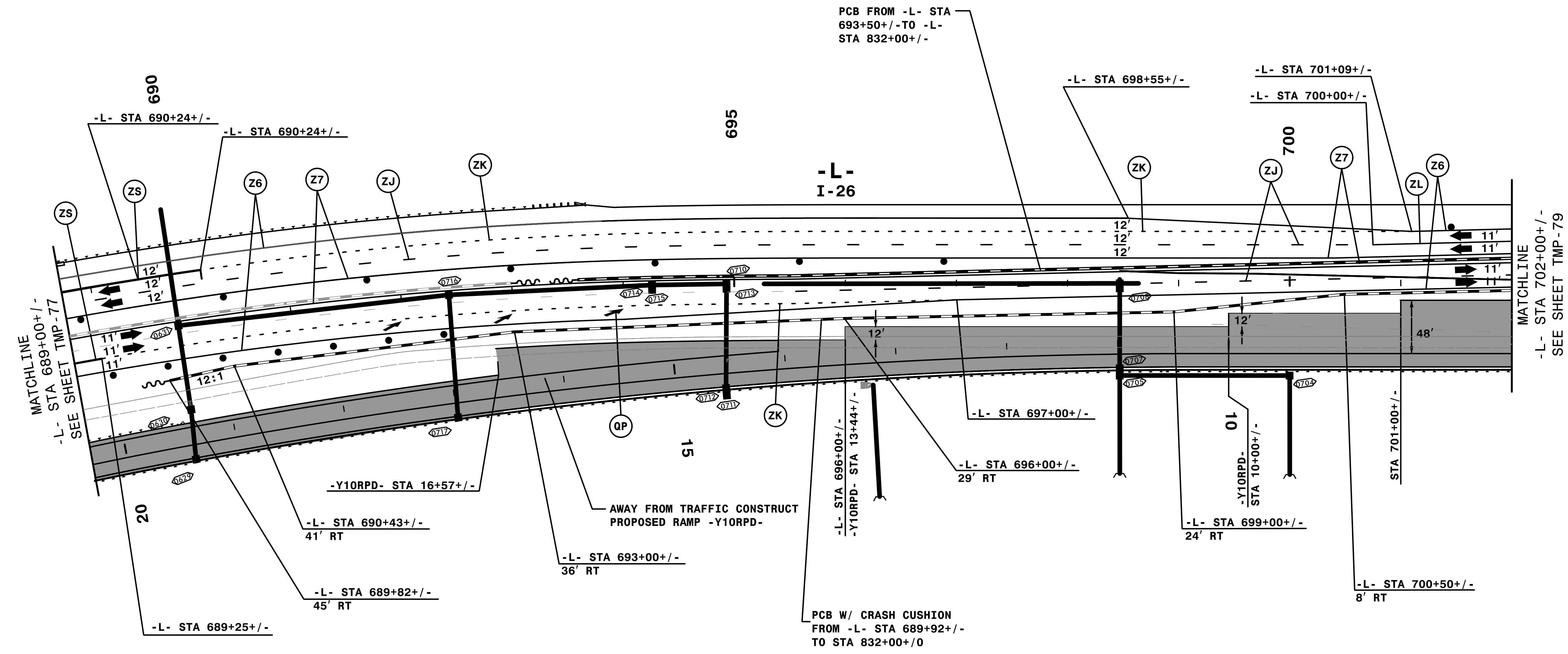
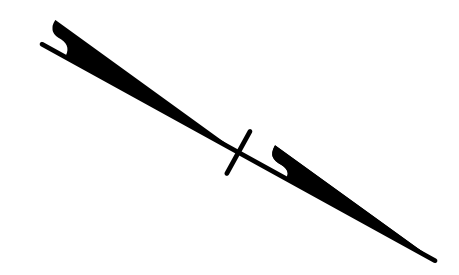

3:36:44 PM
 \\TCN\4400C-TC_ALP3d5.dgn
 9/3/2019

REMOVE CONFLICTING PAVEMENT MARKING.

HNTB
 HNTB NORTH CAROLINA, P.C.
 343 E. Six Forks Road, Suite 200
 Raleigh, North Carolina 27609
 NC License No: C-1554

APPROVED: *Rhonda B. Early*
 DATE: 9/3/2019

DocuSigned by:
 Rhonda B. Early
 F5MC4FSA08BF48A

PROFESSIONAL ENGINEER
 NORTH CAROLINA
 SEAL
 023521
 RHONDA B. EARLY

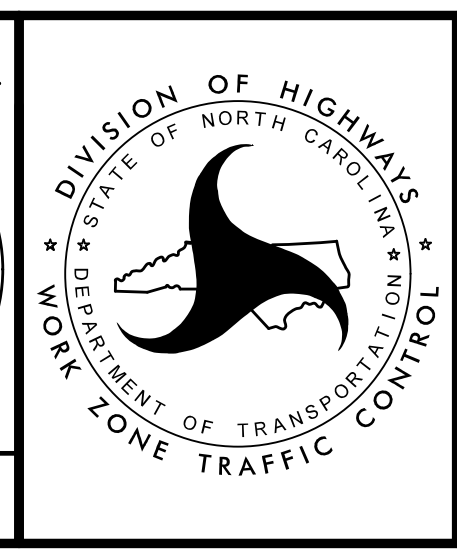

TRANSPORTATION
 MANAGEMENT PLAN

PHASE III
 DETAIL