

**STAGE 5**

(PLACE SINGLE PORTABLE CONCRETE BARRIER, SHIFT TRAFFIC FROM MEDIAN BRIDGE SECTION TO NEW RIGHT LANE BRIDGE, REMOVE TWO PORTABLE CONCRETE BARRIERS (ANCHORED) IN MEDIAN BRIDGE SECTION, REMOVE TEMPORARY ASPHALT PAVEMENT ON BRIDGE, TIE STAGES TOGETHER WITH CLOSURE POURS, GROOVE BRIDGE FLOORS, BUILD CONCRETE MEDIAN BARRIER)

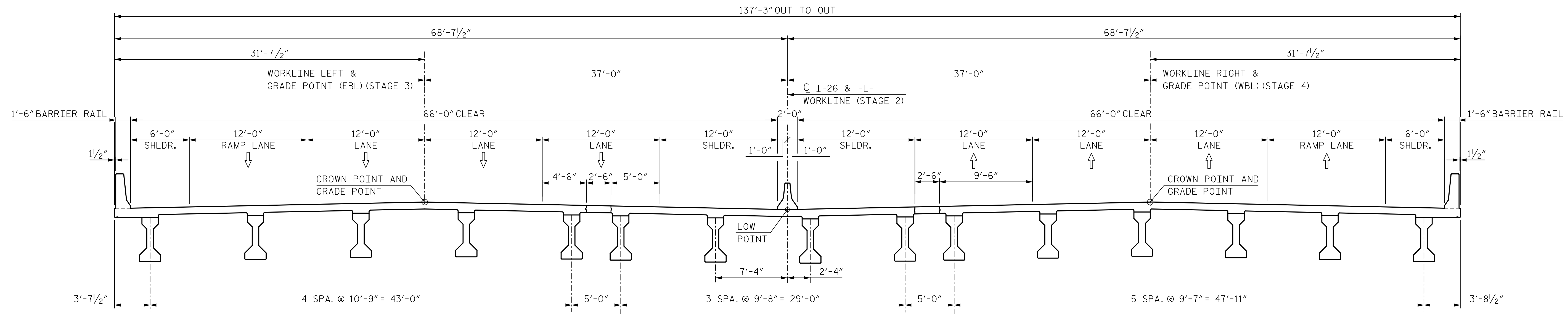

**FINAL CONDITION**

**NOTES:**

**STAGE 5:**  
 INSTALL TEMPORARY ANCHORED BARRIER ON NEWLY CONSTRUCTED RIGHT LANE BRIDGE SECTION. SHIFT TRAFFIC FROM MEDIAN BRIDGE SECTION TO NEWLY CONSTRUCTED RIGHT LANE BRIDGE SECTION. REMOVE TWO TEMPORARY ANCHORED BARRIERS FROM MEDIAN BRIDGE SECTION. REMOVE TEMPORARY ASPHALT PAVEMENT ON THE MEDIAN BRIDGE SECTION BY MILLING TO NEAR CONCRETE SURFACE AND THEN SHOT BLASTING RESIDUAL. TIE ALL STAGES OF BRIDGE TOGETHER WITH 2'-6" CLOSURE POURS. THE FULL WIDTH OF BRIDGE BELOW THE TEMPORARY ASPHALT PAVEMENT SHALL RECEIVE DIAMOND GRINDING. REPLACE TEMPORARY EXPANSION JOINT SEAL COVER PLATE WITH STANDARD FINAL HOLD-DOWN PLATE. CONSTRUCT PERMANENT CONCRETE MEDIAN BARRIER. APPLY SILENCE DECK TREATMENT.

SEE TRAFFIC CONTROL PLANS FOR LOCATION AND PAY LIMITS OF THE PORTABLE CONCRETE BARRIER.

**FINAL CONDITION:**

REMOVE TWO TEMPORARY ANCHORED BARRIERS AND SHIFT TRAFFIC TO THE FINAL CONFIGURATION.

SEE TRAFFIC CONTROL PLANS FOR LOCATION AND PAY LIMITS OF THE PORTABLE CONCRETE BARRIER.

PROJECT NO. I-4400C  
 HENDERSON COUNTY  
 STATION: POT 659+58.95 -L-

SHEET 3 OF 3

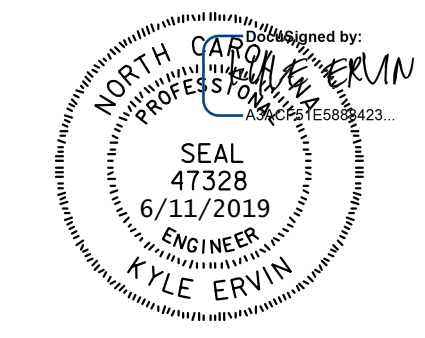

STATE OF NORTH CAROLINA  
 DEPARTMENT OF TRANSPORTATION  
 RALEIGH  
 SUPERSTRUCTURE  
 CONSTRUCTION SEQUENCE

**HNTB** HNTB NORTH CAROLINA, P.C.  
 NC License No. C-1554  
 343 E. Six Forks Rd., Suite 200, Raleigh, N.C. 27609

DRAWN BY B. VAUGHN DATE 11/18  
 CHECKED BY K. ERVIN DATE 11/18  
 DESIGN ENGINEER OF RECORD K. ERVIN DATE 11/18

DWG. NO. 9

**DOCUMENT NOT CONSIDERED FINAL UNLESS ALL SIGNATURES COMPLETED**

REVISIONS						SHEET NO.	
NO.	BY	DATE	NO.	BY	DATE	TOTAL SHEETS	
1			3			1-9	
2			4			81	