

**This electronic collection of documents is provided
for the convenience of the user
and is Not a Certified Document –**

**The documents contained herein were originally issued
and sealed by the individuals whose names and license
numbers appear on each page, on the dates appearing
with their signature on that page.**

**This file or an individual page
shall not be considered a certified document.**

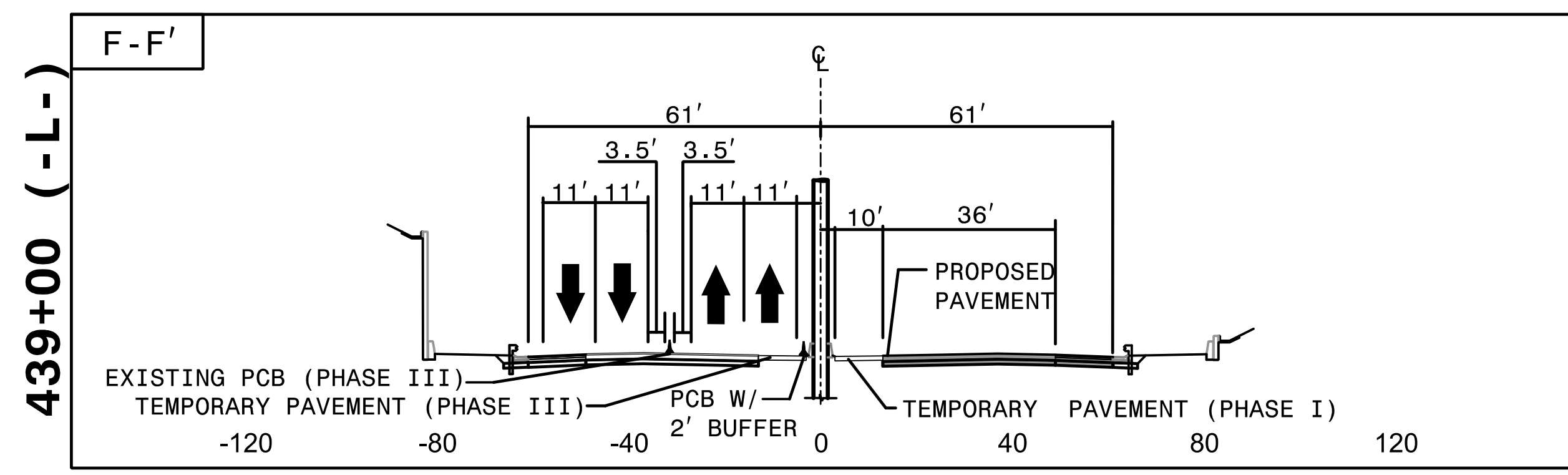
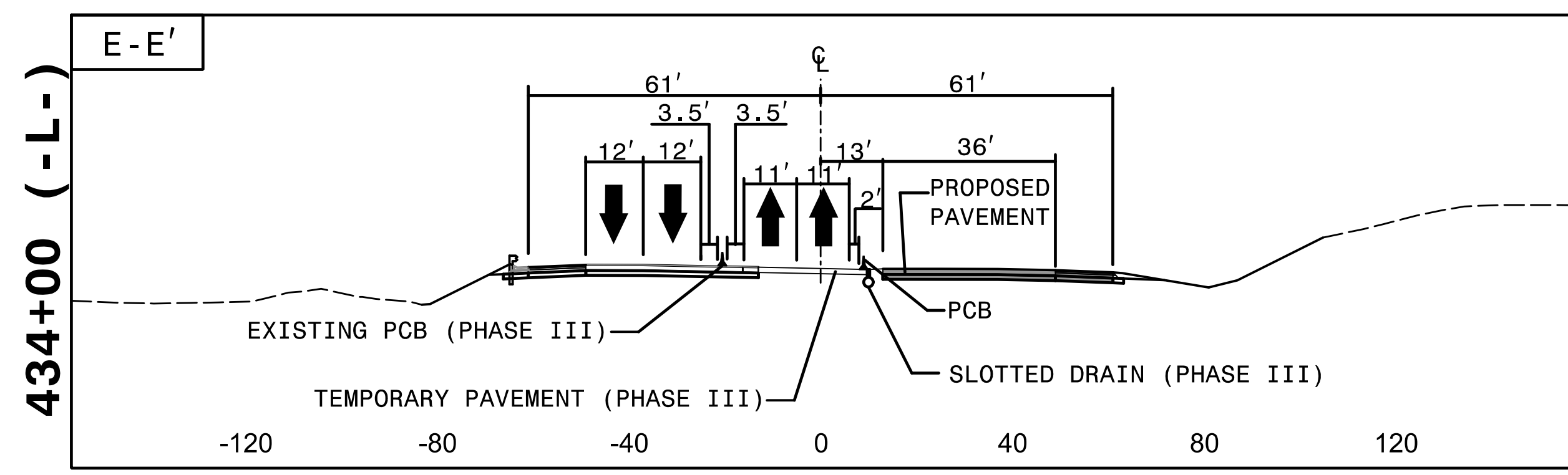
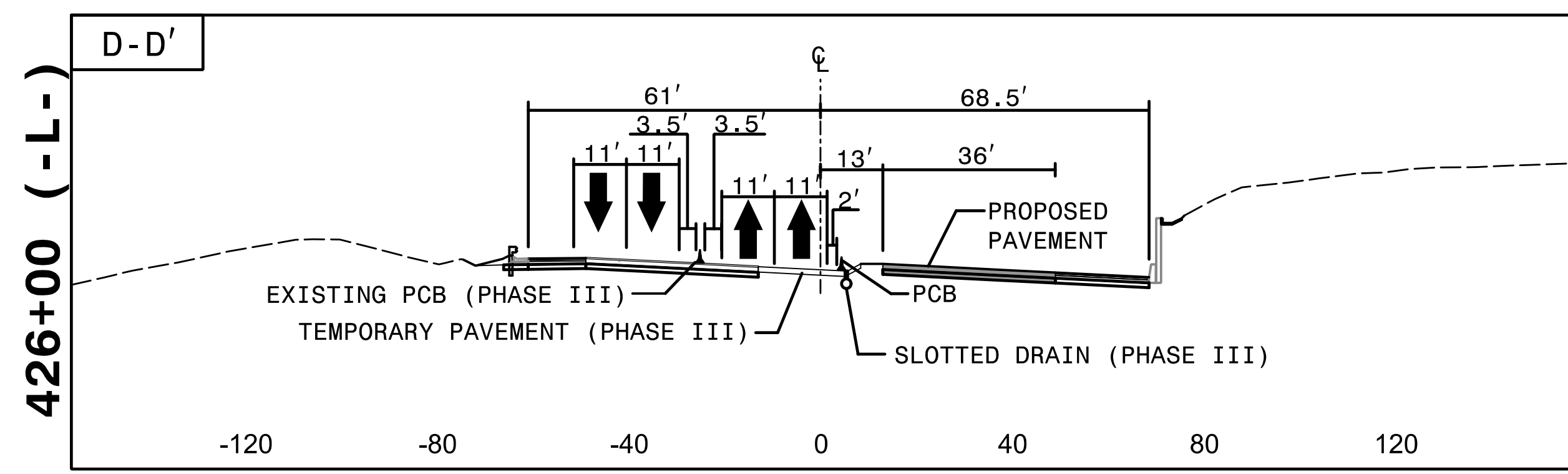
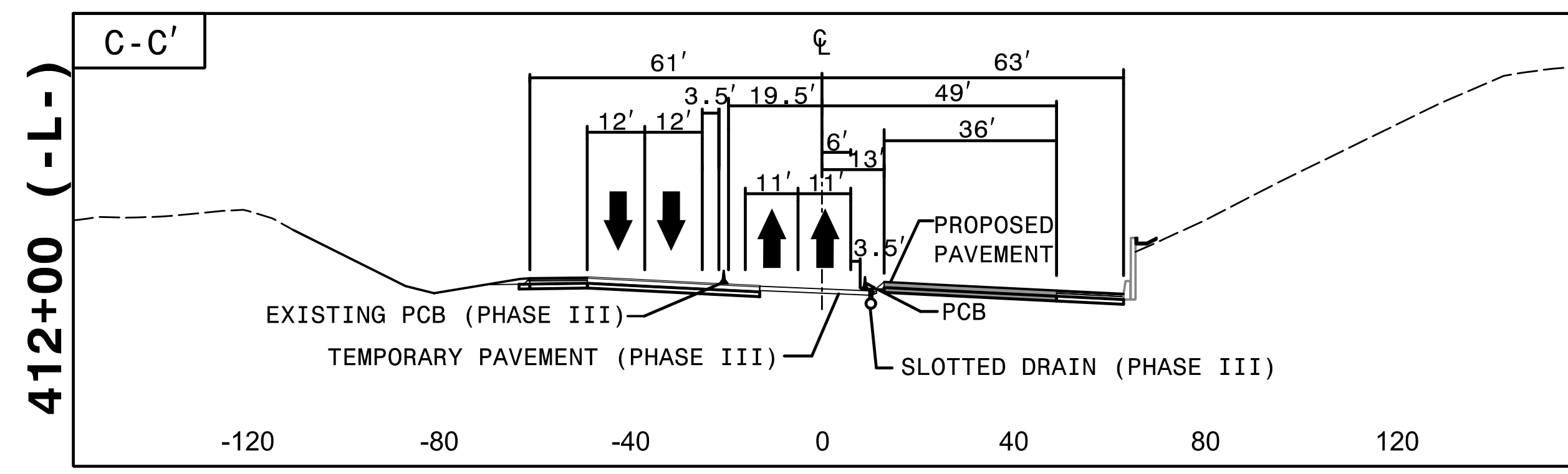
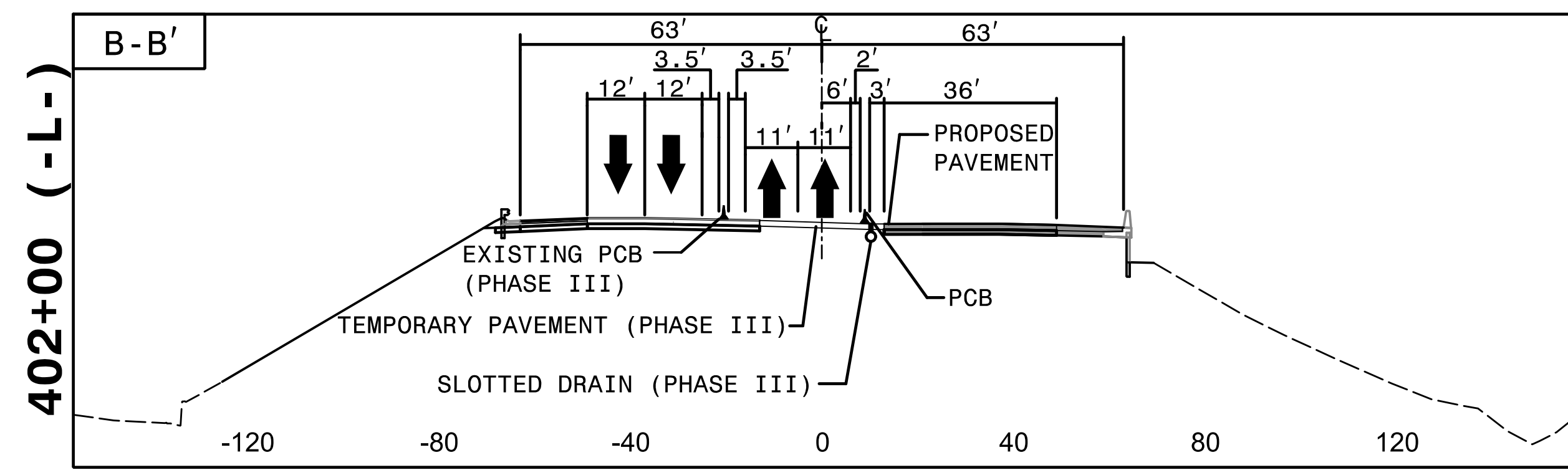
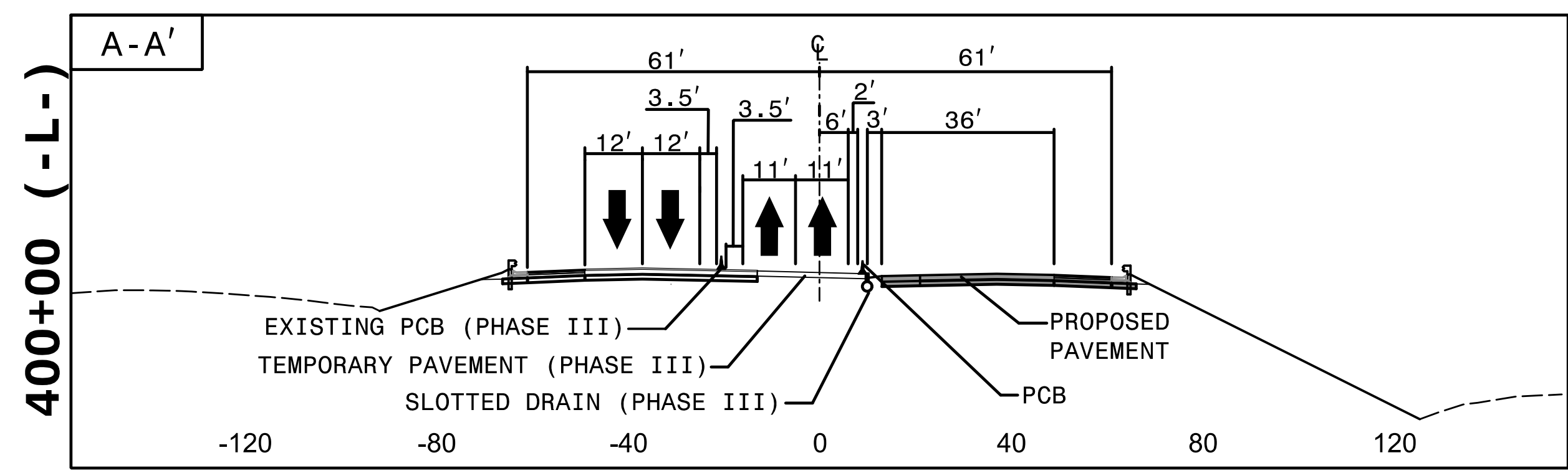

1:06:29 PM
I:\TCN\4400BB_fc_p4 CUTS.dgn
9/3/2019



APPROVED: *Rhonda B. Early*
DATE: 9/3/2019

DocuSigned by:
F34CAFAC8BF48A...

**DOCUMENT NOT CONSIDERED FINAL
UNLESS ALL SIGNATURES COMPLETED**

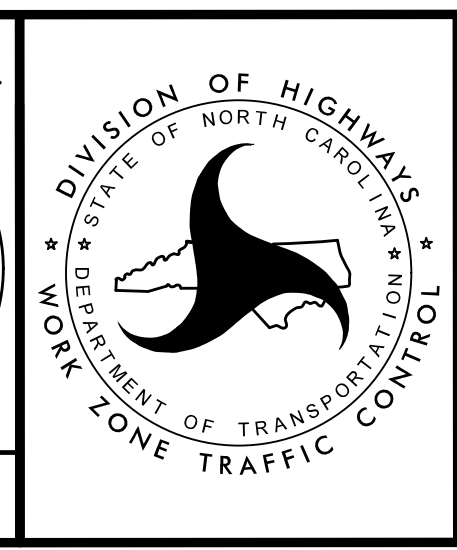

TRANSPORTATION
MANAGEMENT PLAN

PHASE IV
CUT SECTIONS

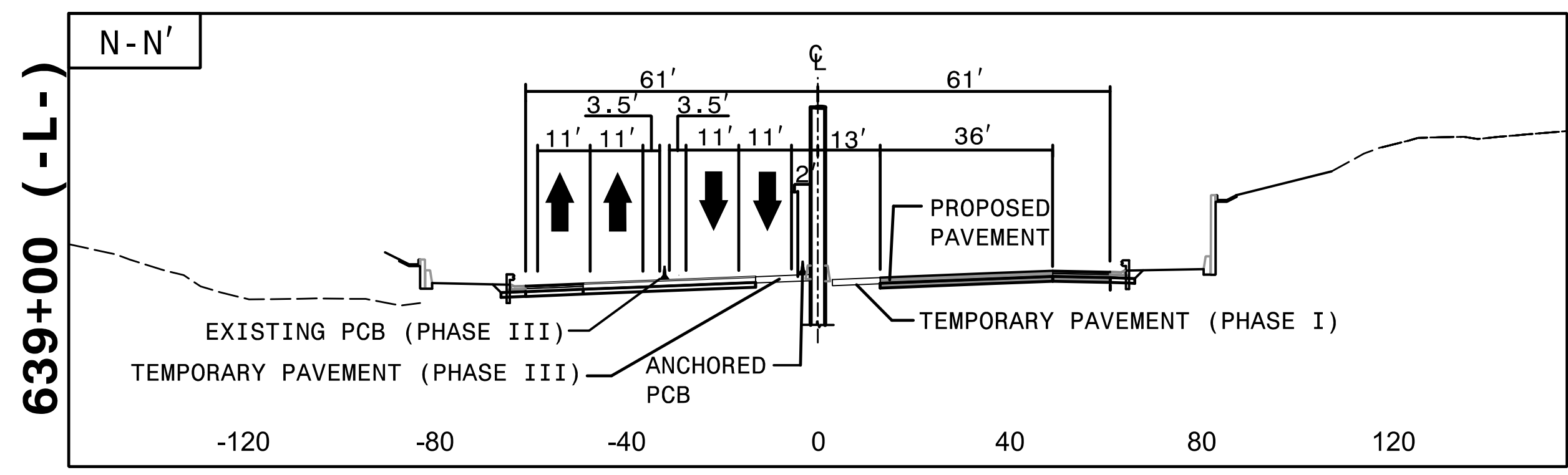
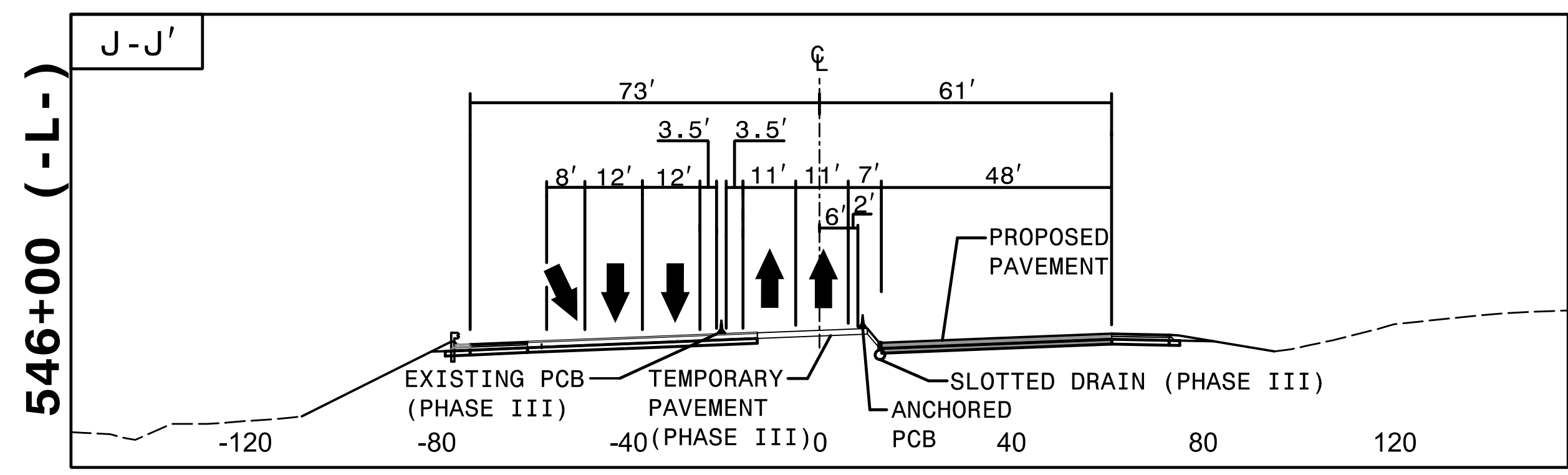
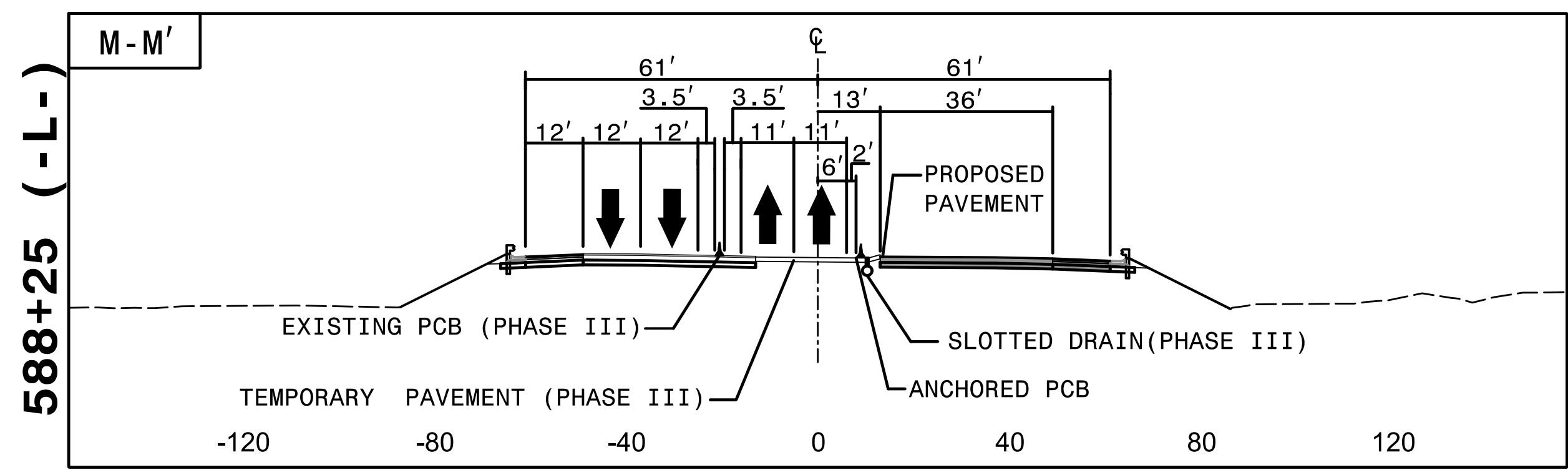
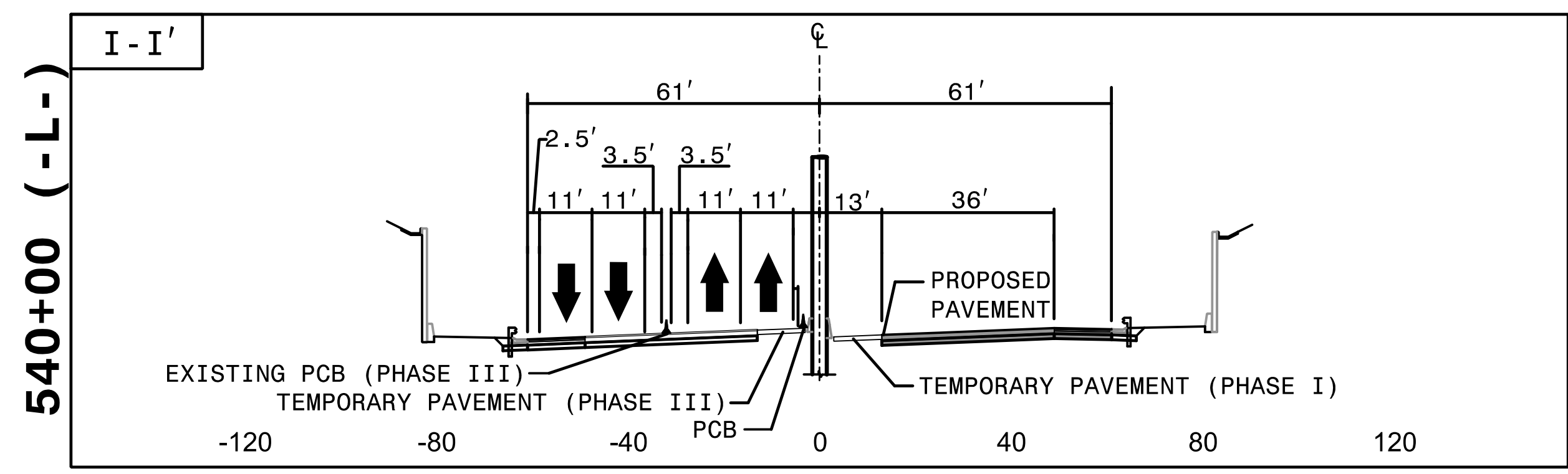
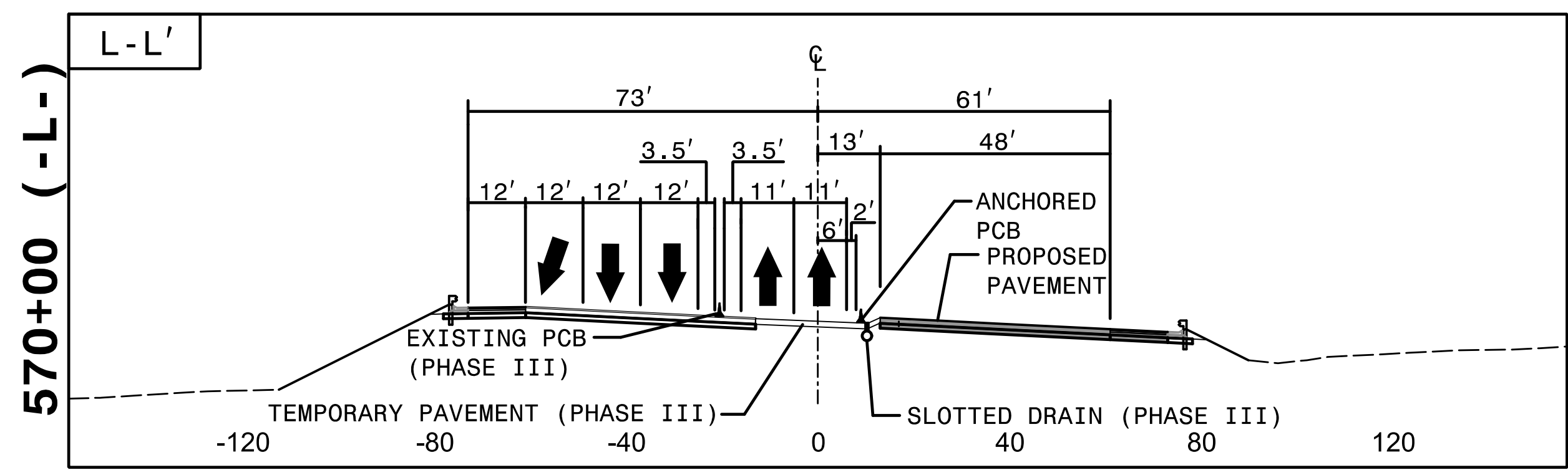
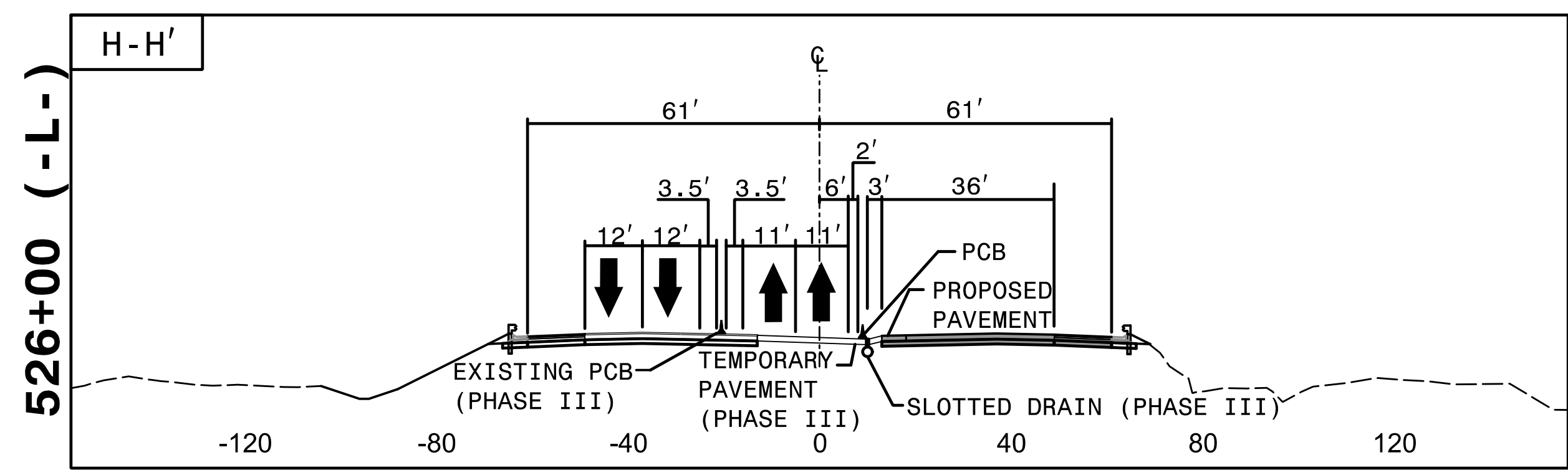
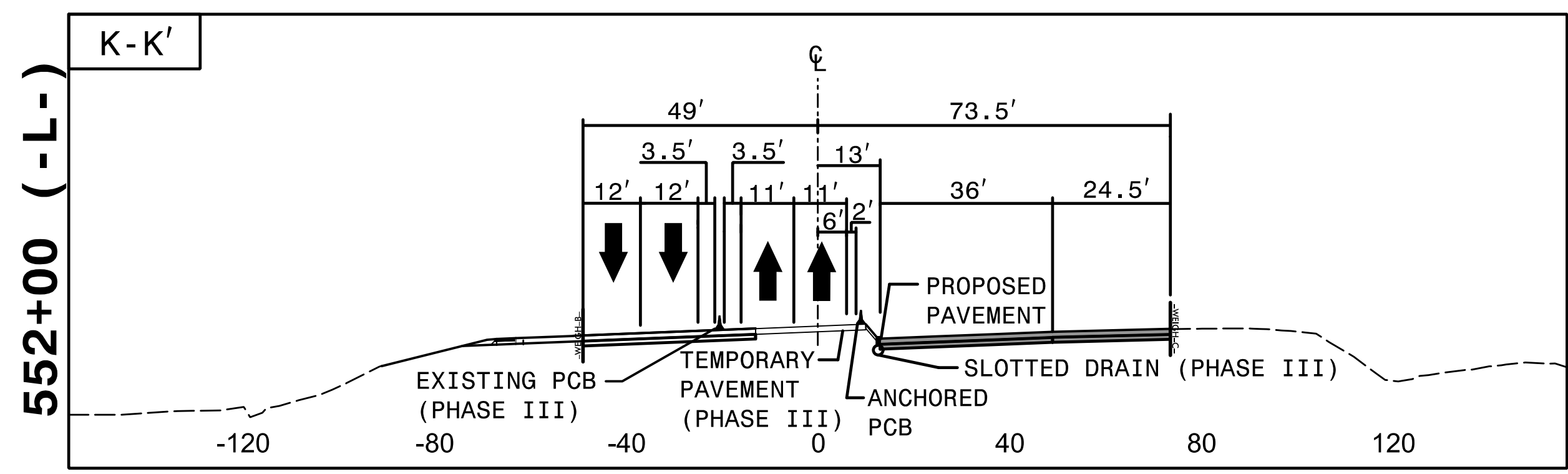
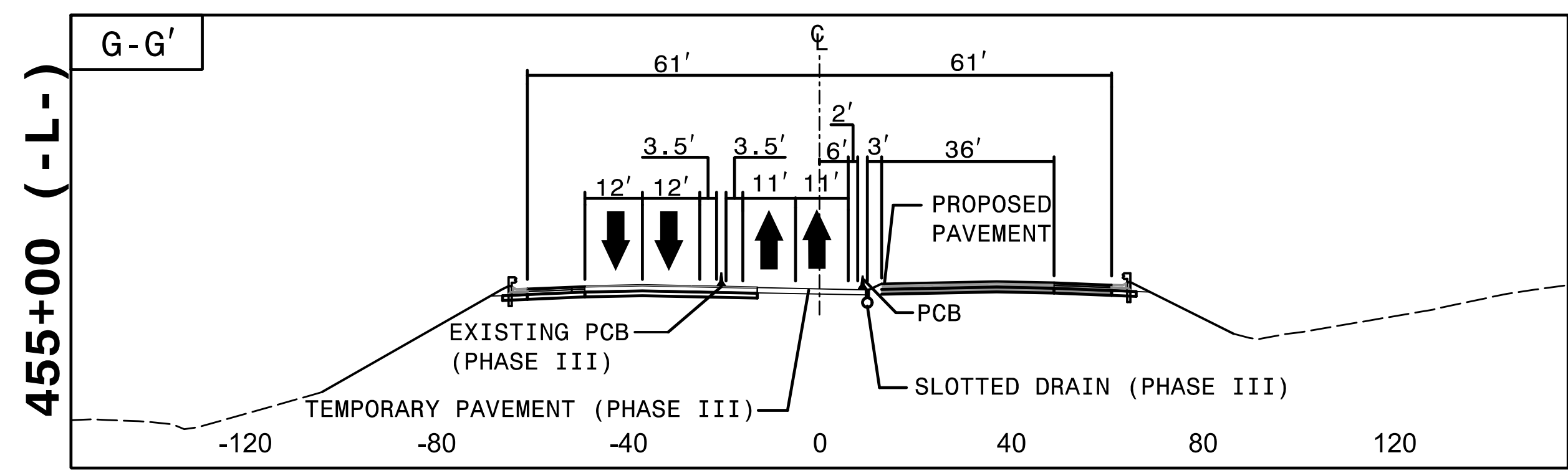

I:\0637 PM
 I:\CP\I4400BB_fc_p4 CUTS.dgn
 9/3/2019



HNTB NORTH CAROLINA, P.C.
 343 E. Six Forks Road, Suite 200
 Raleigh, North Carolina 27609
 NC License No: C-1554

APPROVED: *Rhonda B. Early*
 DATE: 9/3/2019

**DOCUMENT NOT CONSIDERED FINAL
 UNLESS ALL SIGNATURES COMPLETED**

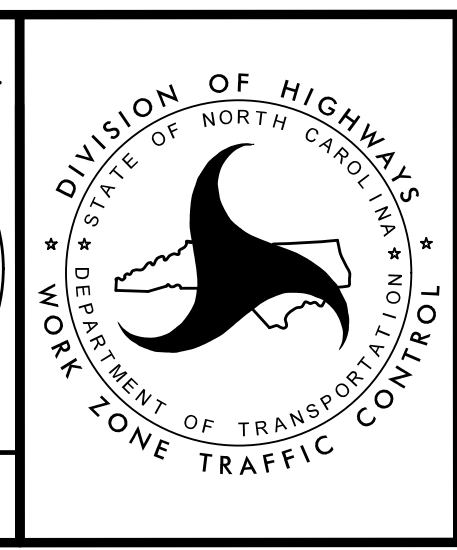

TRANSPORTATION
 MANAGEMENT PLAN

 PHASE IV
 CUT SECTIONS

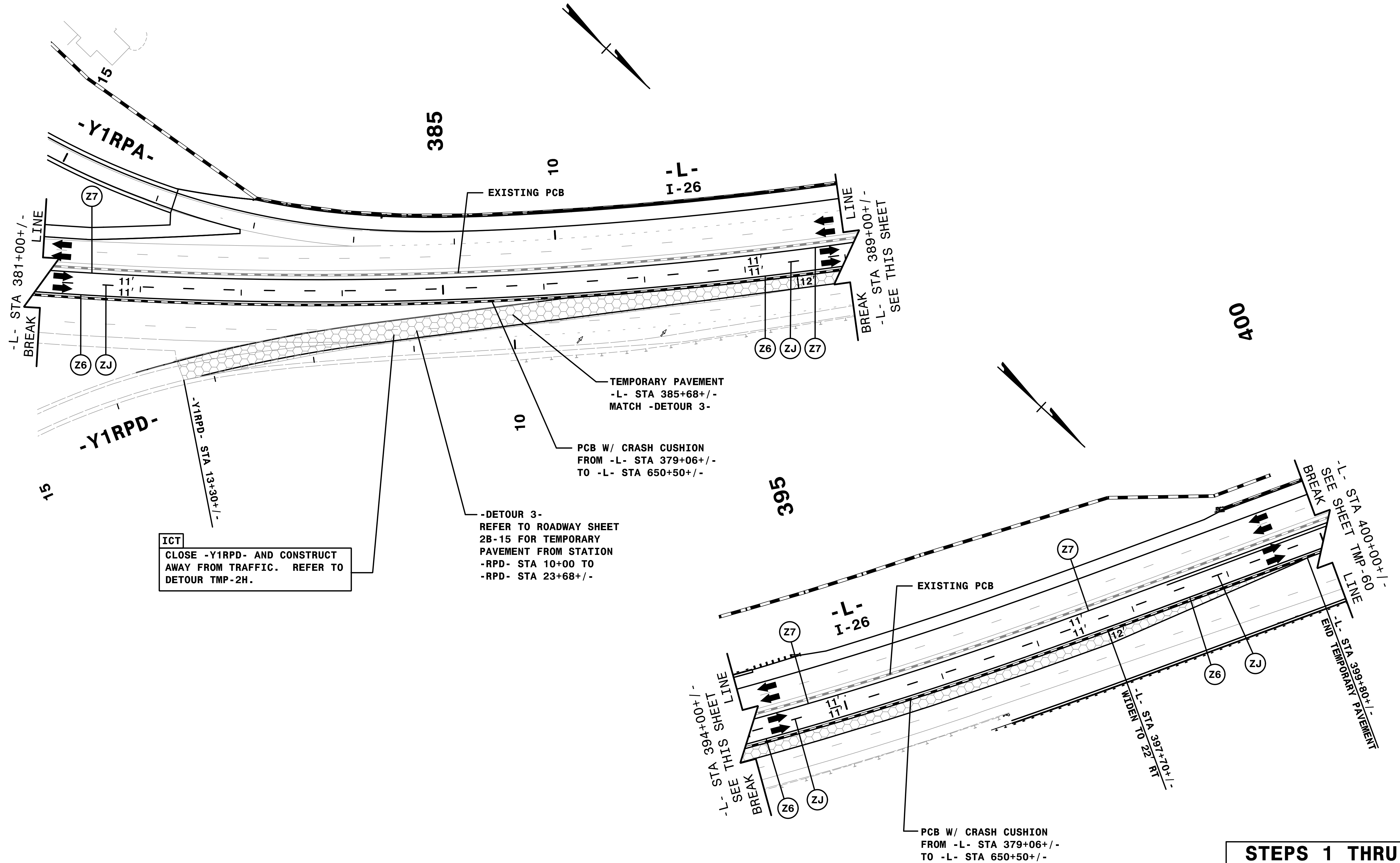

ICT
 CLOSE -Y1RPD- AND CONSTRUCT AWAY FROM TRAFFIC. REFER TO DETOUR TMP-2H.

REFER TO SHEETS TMP-60 THRU TMP-68 FOR PAVEMENT MARKING

HYDRO NOT SHOWN. NO CHANGES TO TEMPORARY DRAINAGE.

REMOVE CONFLICTING PAVEMENT MARKING.

STEPS 1 THRU 3

TRANSPORTATION MANAGEMENT PLAN
 PHASE IV
 DETAIL

APPROVED: *Rhonda B. Early*
 DATE: 9/3/2019

PROFESSIONAL ENGINEER
 NORTH CAROLINA
 SEAL 023521
 RHONDA B. EARLY

DOCUMENT NOT CONSIDERED FINAL UNLESS ALL SIGNATURES COMPLETED



HNTB
 HNTB NORTH CAROLINA, P.C.
 343 E. Six Forks Road, Suite 200
 Raleigh, North Carolina 27609
 NC License No: C-1554

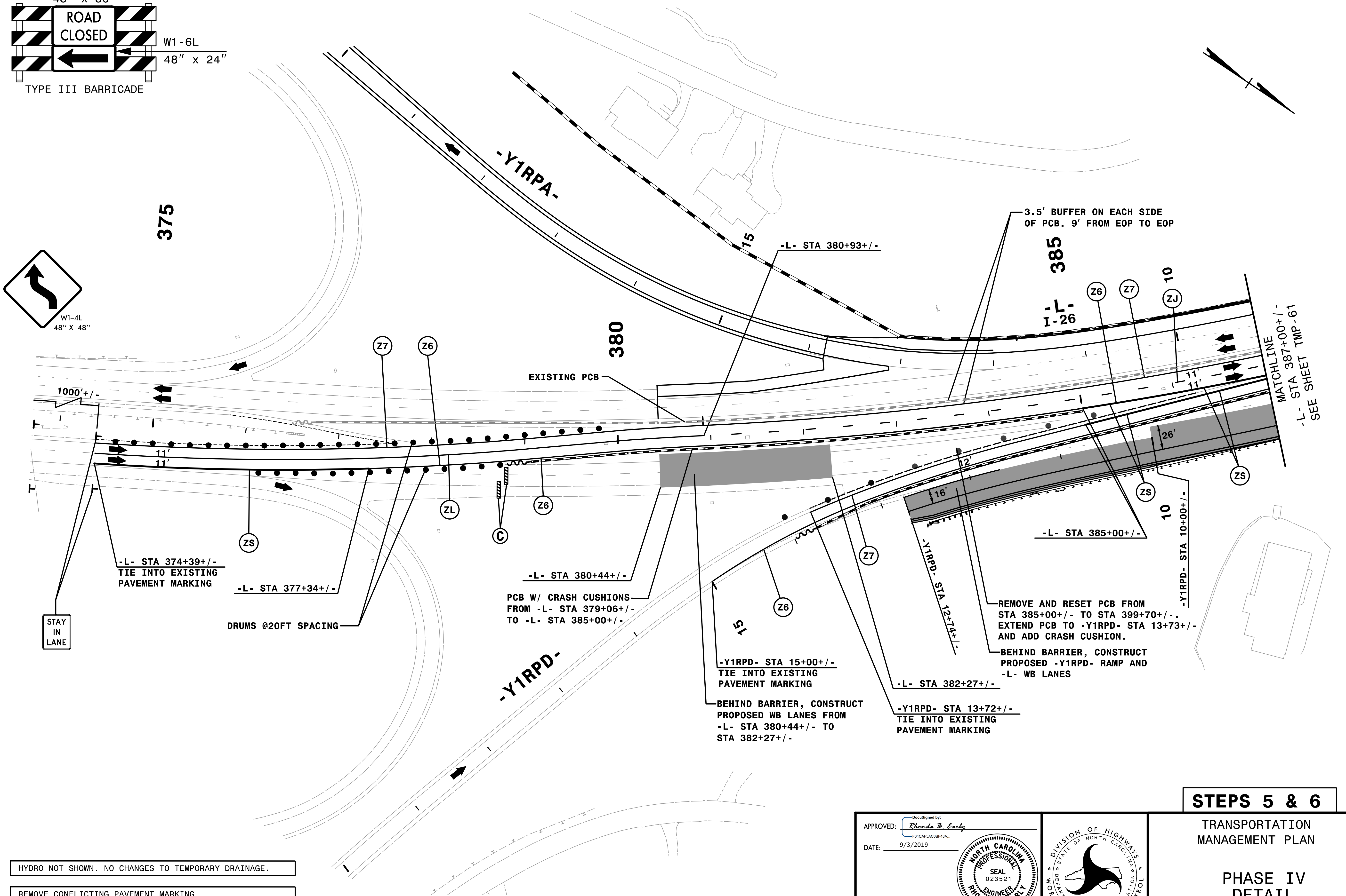
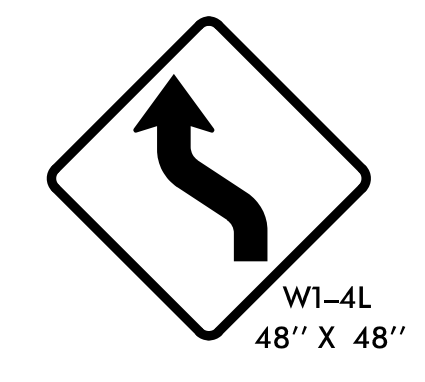
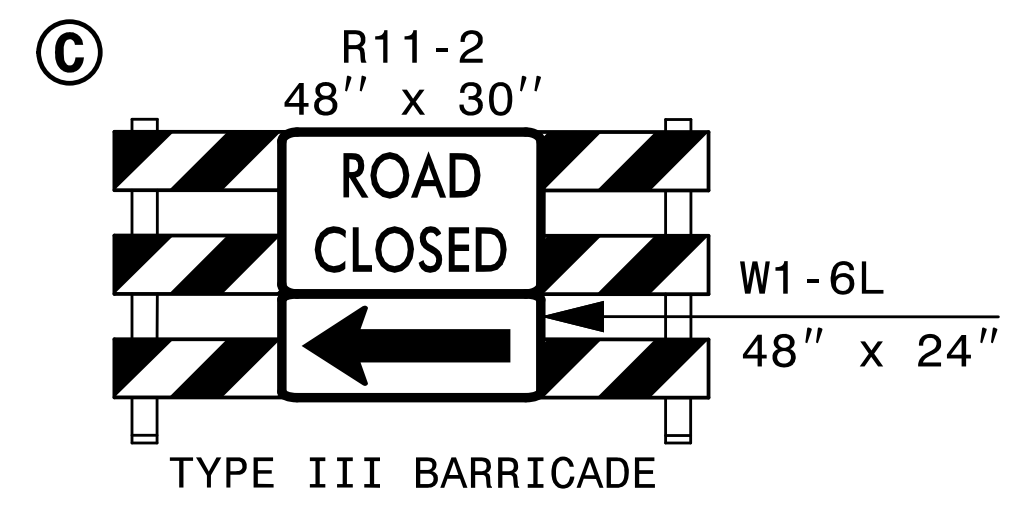

HYDRO NOT SHOWN. NO CHANGES TO TEMPORARY DRAINAGE.

REMOVE CONFLICTING PAVEMENT MARKING.

I:\0655 PM\... I-4400BB.t.c.P4DIA.dgn
9/3/2019

HNTB HNTB NORTH CAROLINA, P.C.
343 E. Six Forks Road, Suite 200
Raleigh, North Carolina 27609
NC License No: C-1554

APPROVED: *Rhonda B. Early*
DATE: 9/3/2019

PROFESSIONAL ENGINEER
NORTH CAROLINA
SEAL
023521
RHONDA B. EARLY

DOCUMENT NOT CONSIDERED FINAL UNLESS ALL SIGNATURES COMPLETED

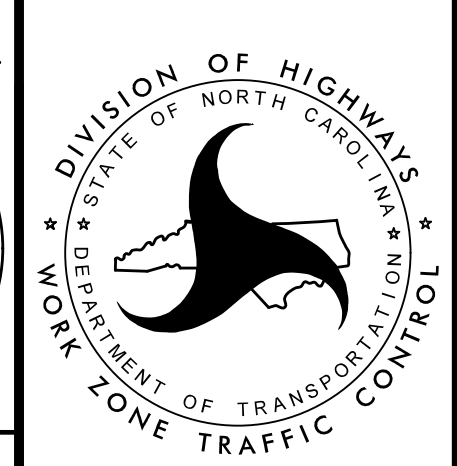

STEPS 5 & 6

TRANSPORTATION
MANAGEMENT PLAN

PHASE IV
DETAIL

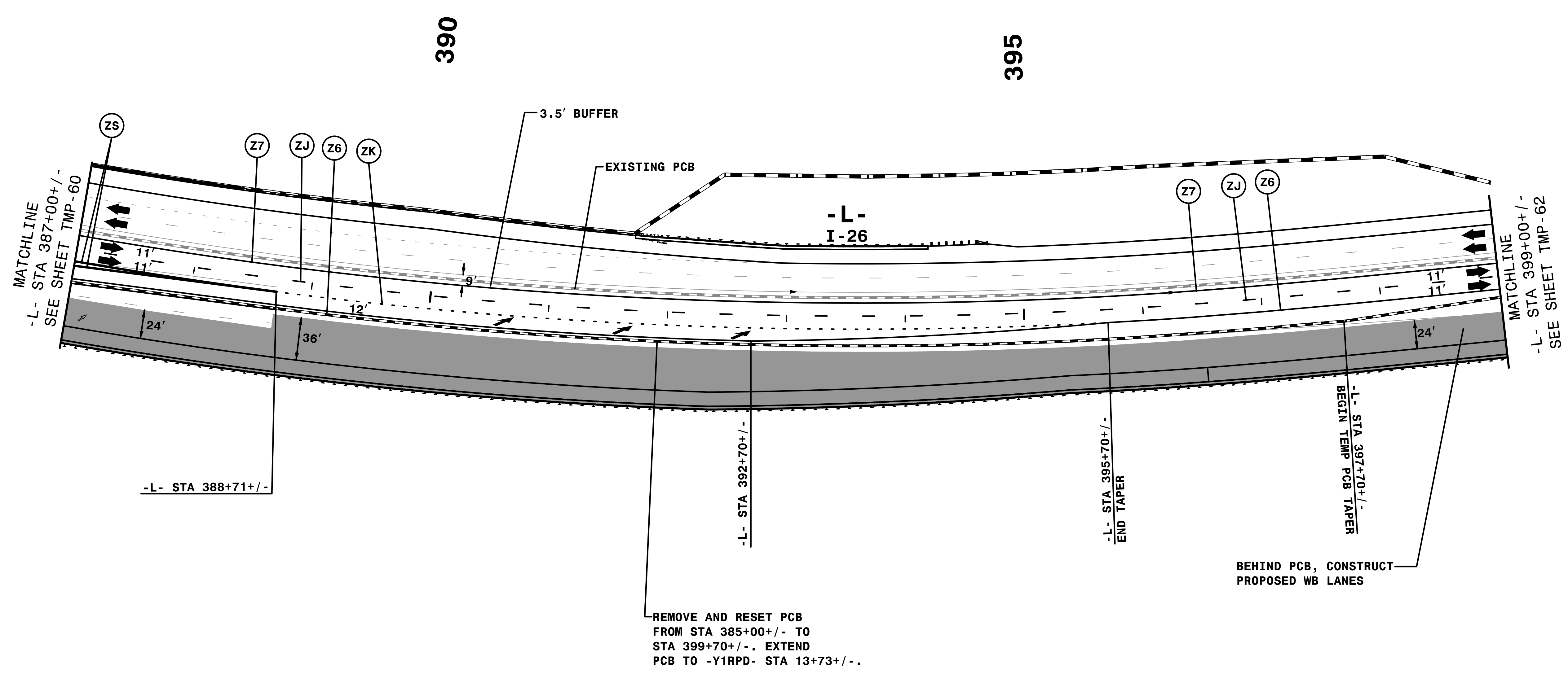
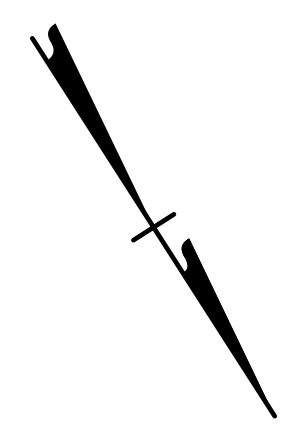

HYDRO NOT SHOWN. NO CHANGES TO TEMPORARY DRAINAGE.

REMOVE CONFLICTING PAVEMENT MARKING.

REMOVE AND RESET PCB FROM STA 385+00 TO STA 399+70. EXTEND PCB TO -Y1RPD- STA 13+73.

BEHIND PCB, CONSTRUCT PROPOSED WB LANES

I:\07\01\PM\I-4400BB-t.c. P4D2.dgn
9/3/2019

HNTB HNTB NORTH CAROLINA, P.C.
343 E. SIX FORKS ROAD, SUITE 200
RALEIGH, NORTH CAROLINA 27609
NC LICENSE NO: C-1554

APPROVED: *Rhonda B. Early*
F34CAFAC8BF48A
DATE: 9/3/2019

PROFESSIONAL ENGINEER
NORTH CAROLINA
SEAL
023521
RHONDA B. EARLY

DOCUMENT NOT CONSIDERED FINAL UNLESS ALL SIGNATURES COMPLETED

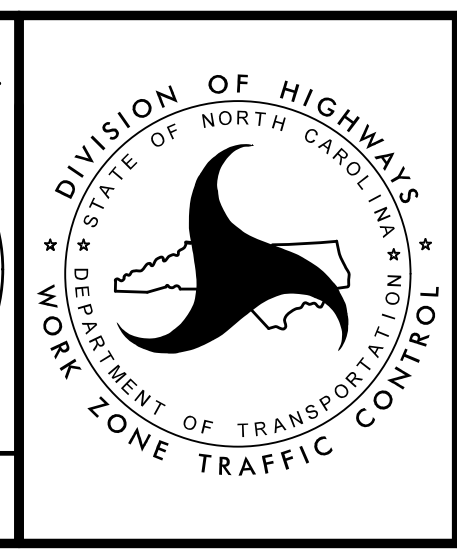

STEPS 5 & 6

TRANSPORTATION MANAGEMENT PLAN

PHASE IV
DETAIL

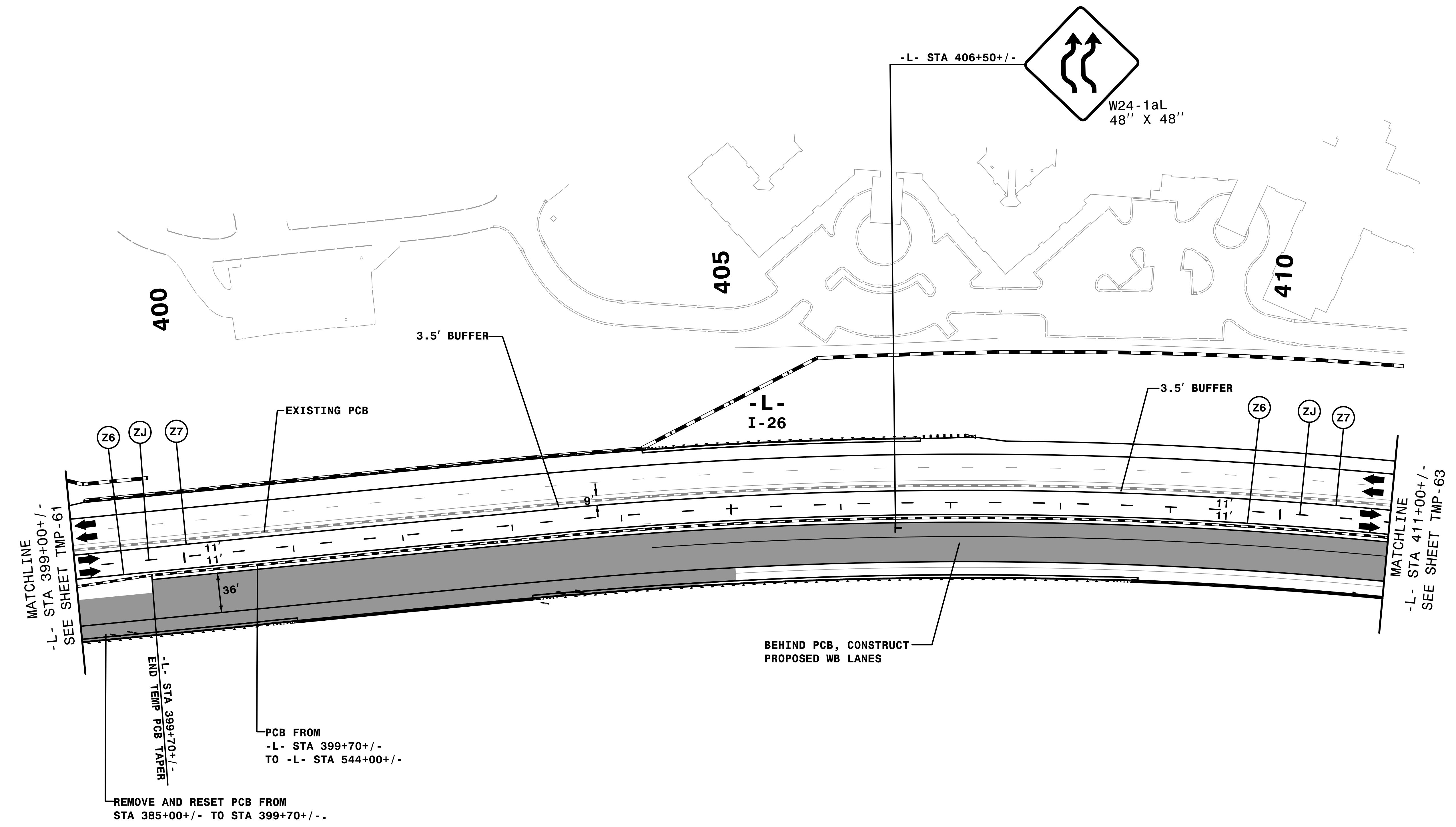

I:\07\07 PM
I:\CP\N\4400BB.t.c.P4D3.dgn
9/3/2019

HYDRO NOT SHOWN. NO CHANGES TO TEMPORARY DRAINAGE.

HNTB
 HNTB NORTH CAROLINA, P.C.
 343 E. Six Forks Road, Suite 200
 Raleigh, North Carolina 27609
 NC License No: C-1554

APPROVED: *Rhonda B. Early*
 F34CAFAC8BF48A
 DATE: 9/3/2019

PROFESSIONAL ENGINEER
 NORTH CAROLINA
 SEAL
 023521
 RHONDA B. EARLY

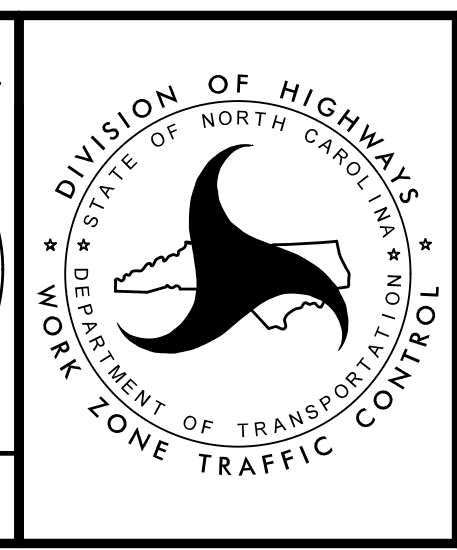

STEPS 5 & 6

TRANSPORTATION
 MANAGEMENT PLAN

PHASE IV
 DETAIL

DOCUMENT NOT CONSIDERED FINAL
UNLESS ALL SIGNATURES COMPLETED

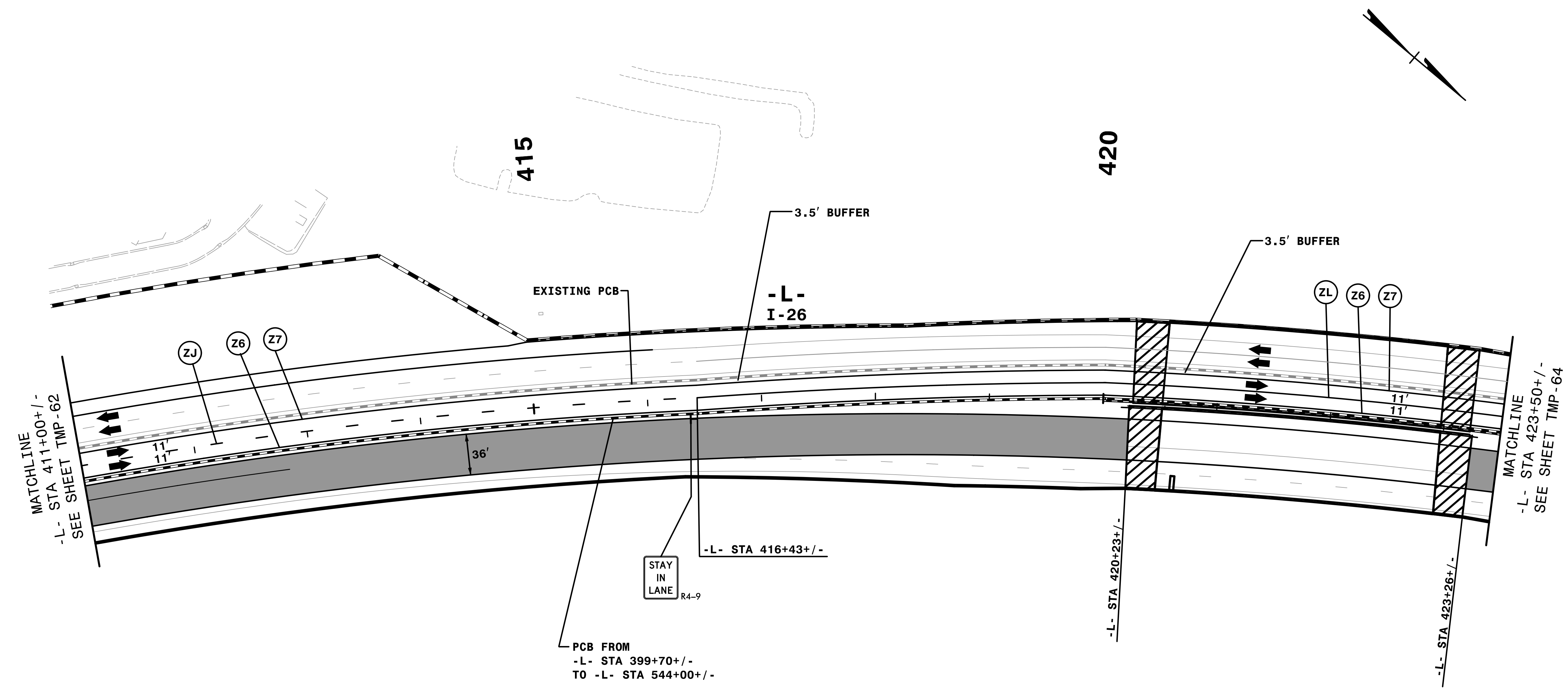

HYDRO NOT SHOWN. NO CHANGES TO TEMPORARY DRAINAGE.

REMOVE CONFLICTING PAVEMENT MARKING.

I:\07143_PM\I-4400BB.tcd.P4D4.dgn
9/3/2019

STEPS 5 & 6

TRANSPORTATION
MANAGEMENT PLAN

PHASE IV
DETAIL

HNTB HNTB NORTH CAROLINA, P.C.
343 E. SIX FORKS ROAD, SUITE 200
RALEIGH, NORTH CAROLINA 27609
NC LICENSE NO: C-1554

APPROVED: *Rhonda B. Early*
F34CAFAC8BF46A

DATE: 9/3/2019

NORTH CAROLINA
PROFESSIONAL
ENGINEERS
RHONDA B. EARLY
SEAL
023521

**DOCUMENT NOT CONSIDERED FINAL
UNLESS ALL SIGNATURES COMPLETED**

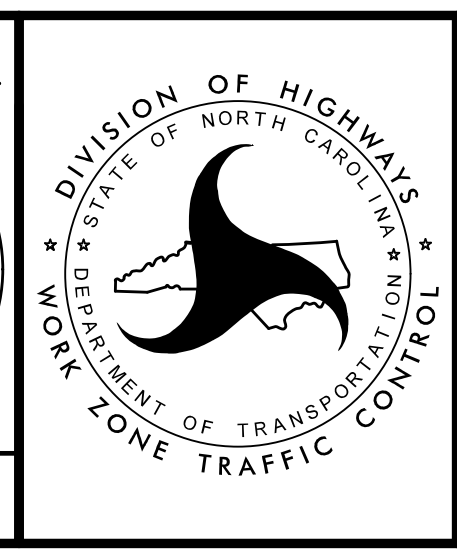

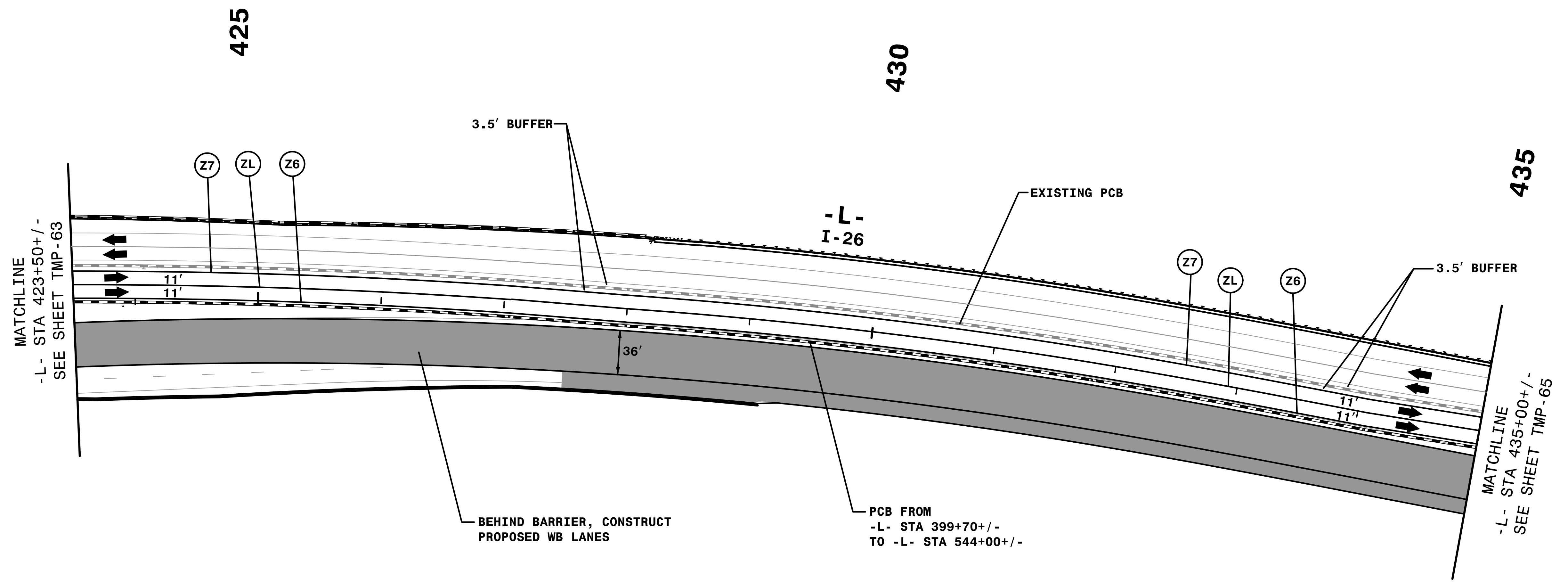

I:\07419_PM\I-4400BB.tcd.P4D5.dgn
9/3/2019

HYDRO NOT SHOWN. NO CHANGES TO TEMPORARY DRAINAGE.

REMOVE CONFLICTING PAVEMENT MARKING.

HNTB HNTB NORTH CAROLINA, P.C.
343 E. SIX FORKS ROAD, SUITE 200
RALEIGH, NORTH CAROLINA 27609
NC LICENSE NO: C-1554

APPROVED: *Rhonda B. Early*
F34CAFAC8BF48A
DATE: 9/3/2019

PROFESSIONAL ENGINEER SEAL
NORTH CAROLINA
023521
RHONDA B. EARLY

DOCUMENT NOT CONSIDERED FINAL UNLESS ALL SIGNATURES COMPLETED

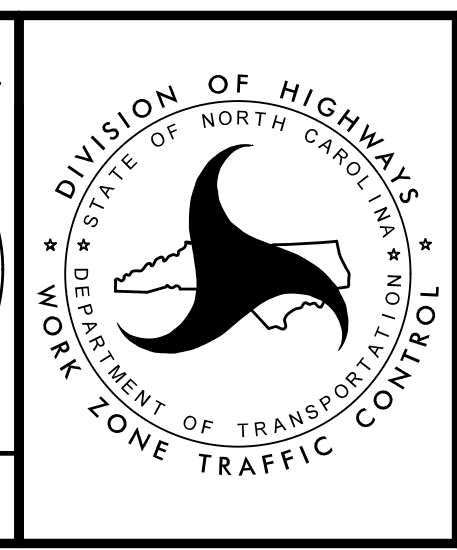

STEPS 5 & 6

TRANSPORTATION MANAGEMENT PLAN

PHASE IV DETAIL

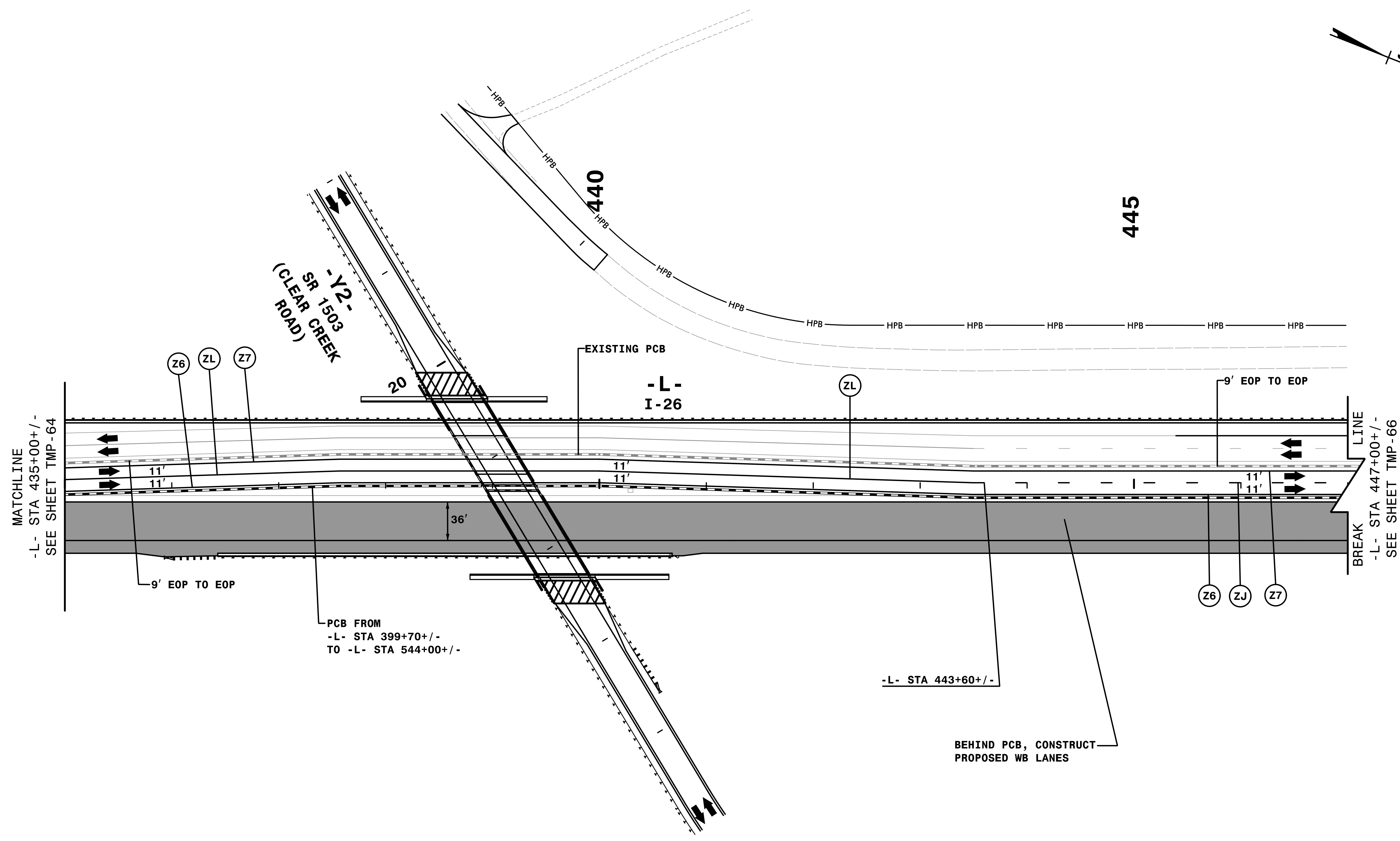
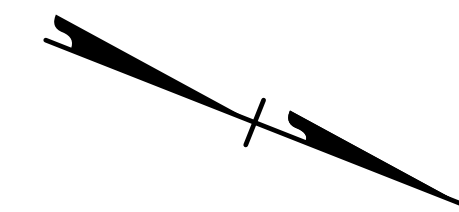

MATCHLINE
-L- STA 435+00+/-
SEE SHEET TMP-64

BREAK
-L- STA 447+00+/-
SEE SHEET TMP-66

- HYDRO NOT SHOWN. NO CHANGES TO TEMPORARY DRAINAGE.
- REMOVE CONFLICTING PAVEMENT MARKING.

STEPS 5 & 6

TRANSPORTATION
MANAGEMENT PLAN

PHASE IV
DETAIL

APPROVED: *Rhonda B. Early*
DATE: 9/3/2019

DocuSigned by:
F34CAFAC8BF48A

PROFESSIONAL ENGINEER
NORTH CAROLINA
SEAL
023521
RHONDA B. EARLY

**DOCUMENT NOT CONSIDERED FINAL
UNLESS ALL SIGNATURES COMPLETED**

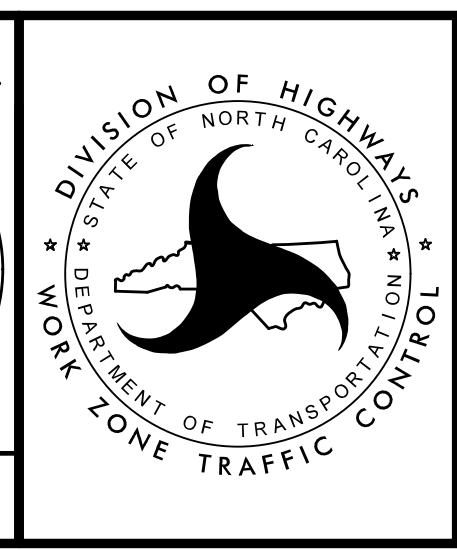

HNTB HNTB NORTH CAROLINA, P.C.
343 E. Six Forks Road, Suite 200
Raleigh, North Carolina 27609
NC License No: C-1554

I:\07126 PM
TCN\I-4400BB-t.c. P4D6.dgn
9/3/2019

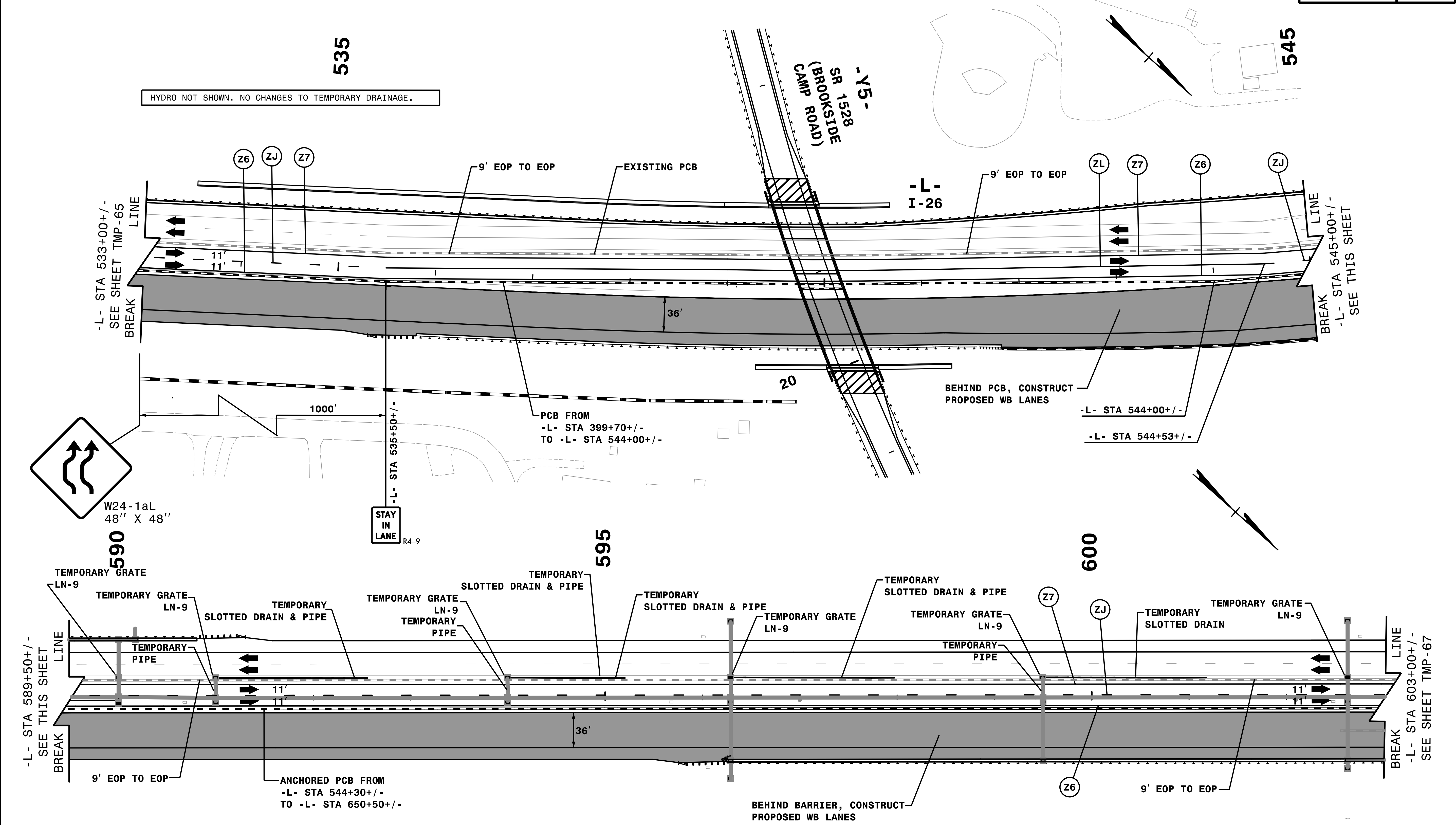

STEPS 5 & 6

TRANSPORTATION MANAGEMENT PLAN

PHASE IV DETAIL

HNTB
HNTB NORTH CAROLINA, P.C.
343 E. SIX FORKS ROAD, SUITE 200
RALEIGH, NORTH CAROLINA 27609
NC LICENSE NO: C-1554

APPROVED: *Rhonda B. Early*
DATE: 9/3/2019

NORTH CAROLINA
PROFESSIONAL
ENGINEER
RHOWDA B. EARLY
023521

DOCUMENT NOT CONSIDERED FINAL
UNLESS ALL SIGNATURES COMPLETED

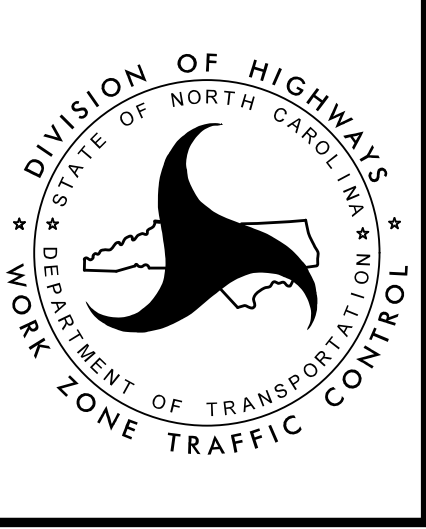

I:07:33 PM
T:\CP\N\I-4400BB.t.c.P4D14.dgn
9/3/2019

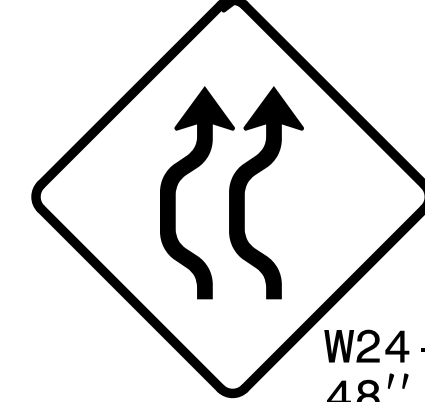
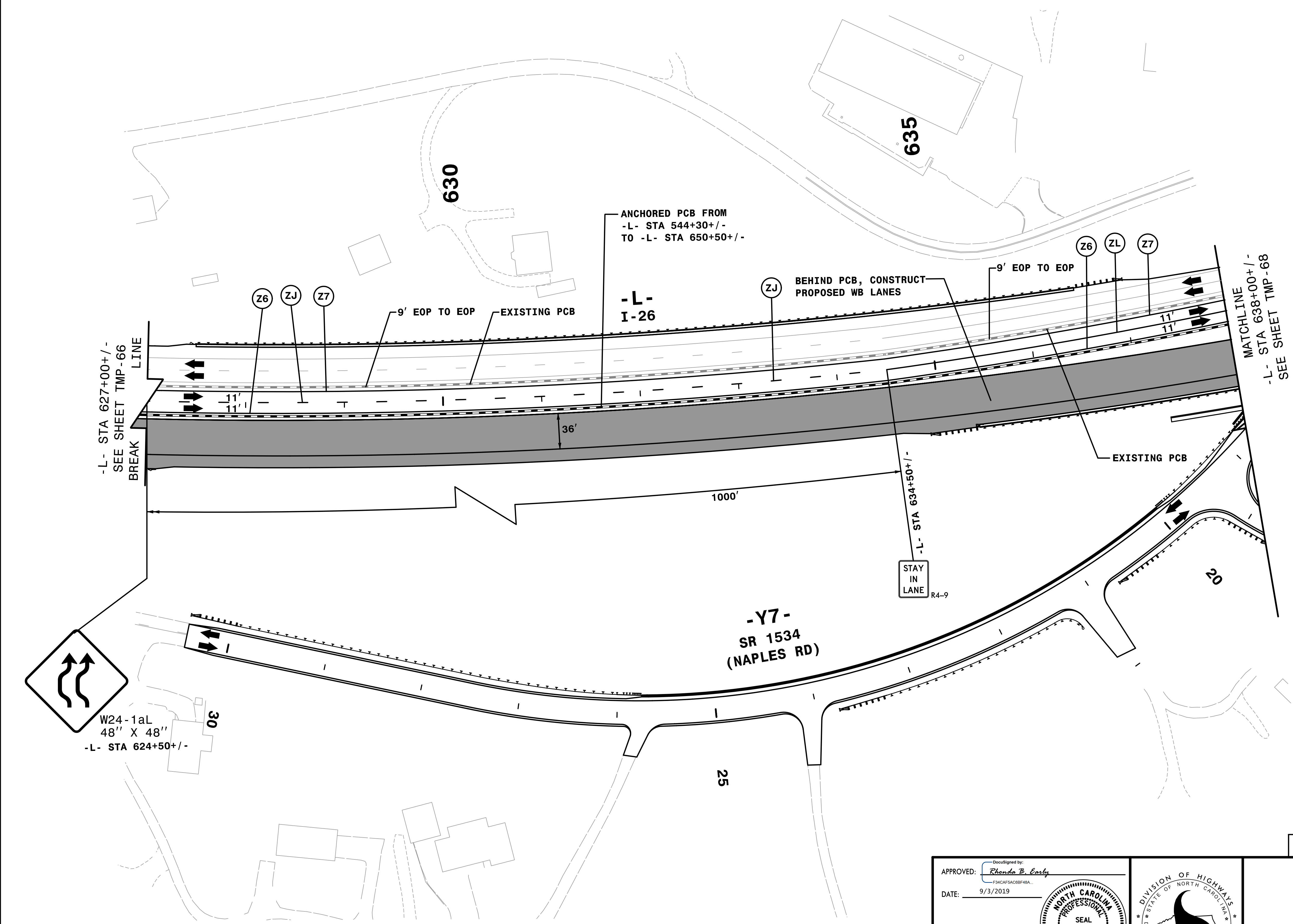
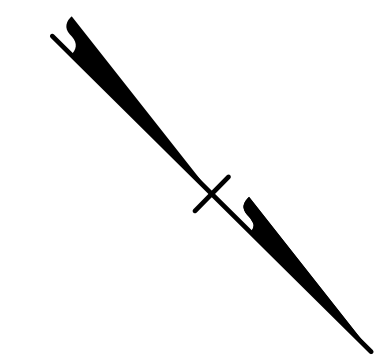

HYRDO NOT SHOWN. NO CHANGES TO TEMPORARY DRAINAGE.

SEE PMP FOR PAVMENT MARKING STATIONS.



APPROVED: *Rhonda B. Early*
F34CAFAC8BF48A

DATE: 9/3/2019

**DOCUMENT NOT CONSIDERED FINAL
UNLESS ALL SIGNATURES COMPLETED**

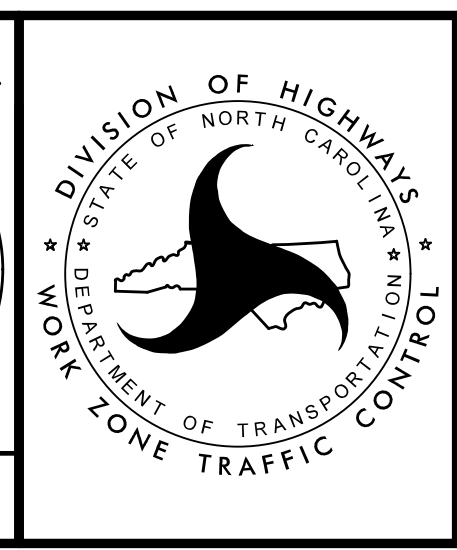

STEPS 5 & 6

TRANSPORTATION
MANAGEMENT PLAN

PHASE IV
DETAIL

I:\07139 PM
 I-4400BB.tcd
 9/3/2019

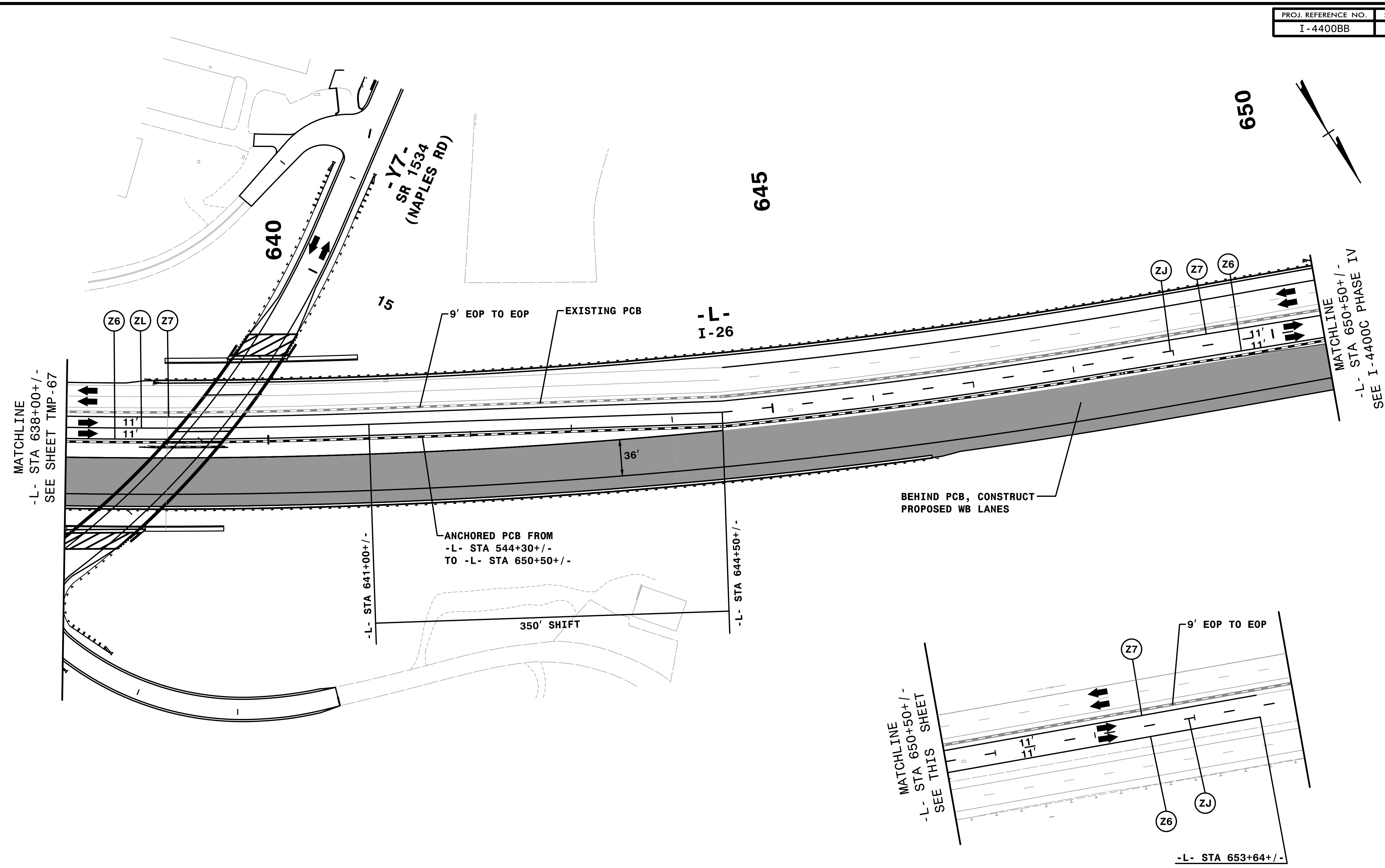

650

645

640

15

-L-
I-26

MATCHLINE
-L- STA 638+00+/-
SEE SHEET TMP-67

MATCHLINE
-L- STA 650+50+/-
SEE I-4400C PHASE IV

BEHIND PCB, CONSTRUCT
PROPOSED WB LANES

ANCHORED PCB FROM
-L- STA 544+30+/-
TO -L- STA 650+50+/-

-L- STA 641+00+/-

-L- STA 644+50+/-

350' SHIFT

36'

MATCHLINE
-L- STA 650+50+/-
SEE THIS SHEET

-L- STA 653+64+/-

HYDRO NOT SHOWN. NO CHANGES TO TEMPORARY DRAINAGE.

REMOVE CONFLICTING PAVEMENT MARKING.

STEPS 5 & 6

TRANSPORTATION
MANAGEMENT PLAN

PHASE IV
DETAIL

APPROVED: *Rhonda B. Early*
F34C2FAC8BF48A

DATE: 9/3/2019

**DOCUMENT NOT CONSIDERED FINAL
UNLESS ALL SIGNATURES COMPLETED**

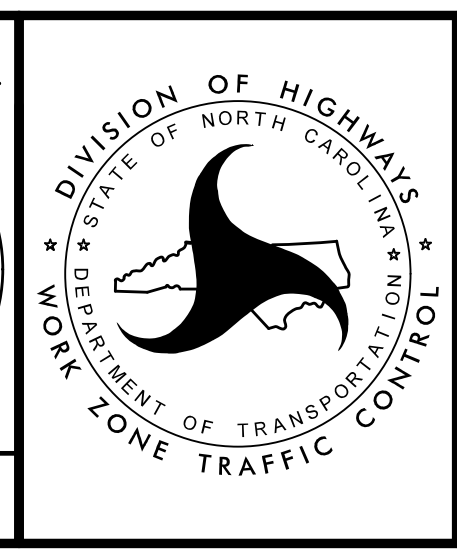

HNTB

HNTB NORTH CAROLINA, P.C.
349 E. Six Forks Road, Suite 200
Raleigh, North Carolina 27609
NC License No: C-1554

I:\07450_PM
I-4400BB.tcd
I-4400BB.tcd
9/3/2019

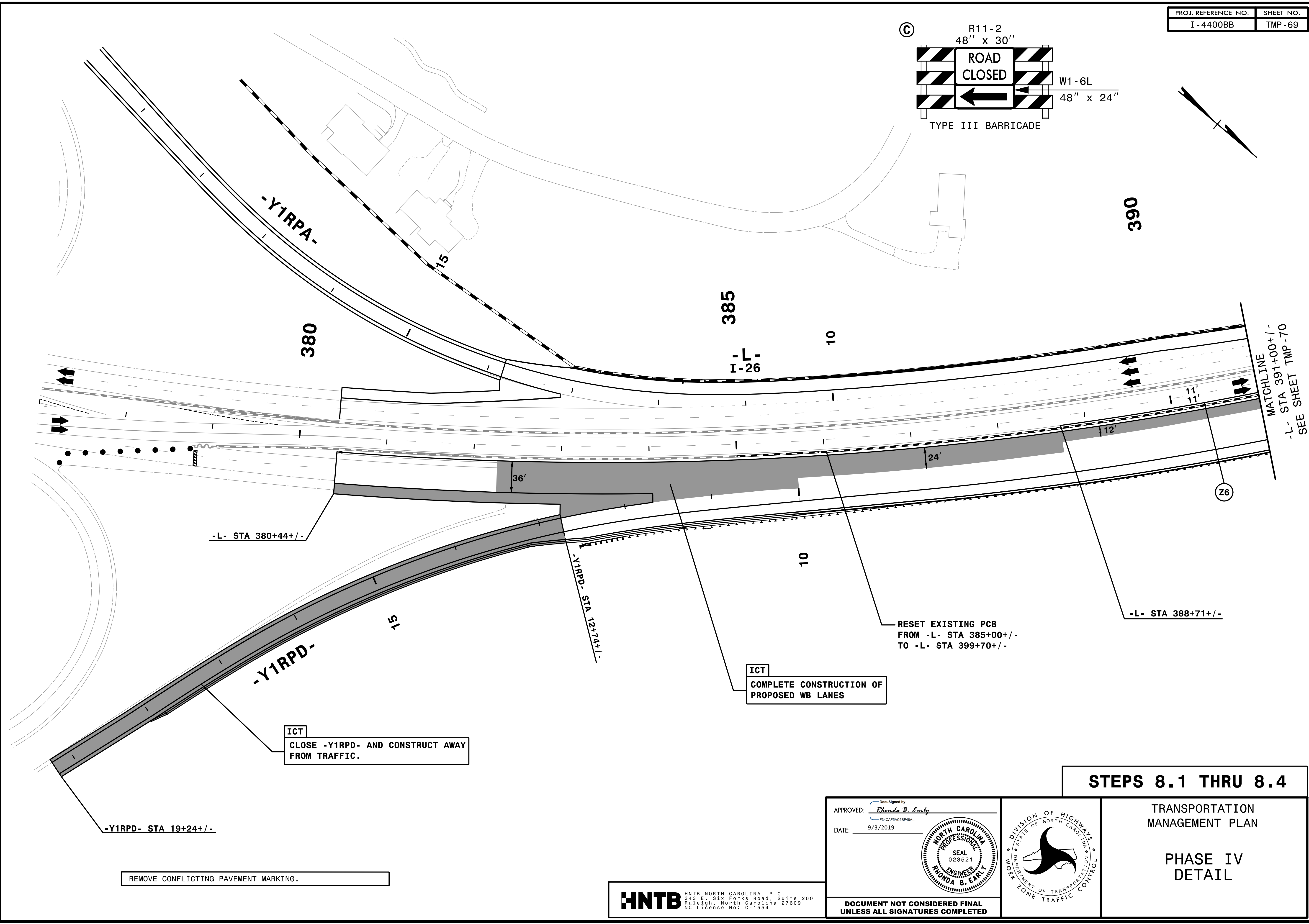
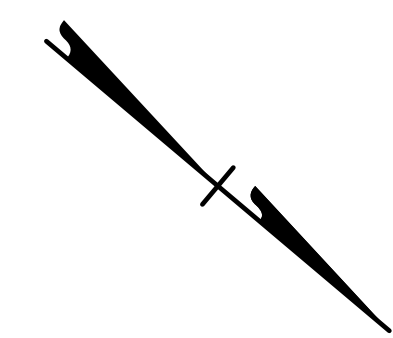
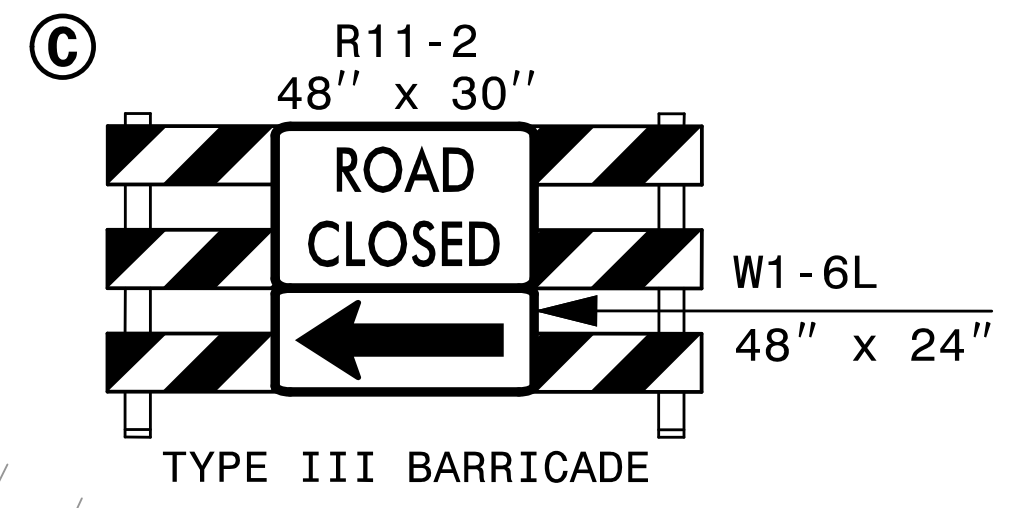

ICT
CLOSE -Y1RPD- AND CONSTRUCT AWAY FROM TRAFFIC.

ICT
COMPLETE CONSTRUCTION OF PROPOSED WB LANES

RESET EXISTING PCB FROM -L- STA 385+00+/- TO -L- STA 399+70+/-

REMOVE CONFLICTING PAVEMENT MARKING.

STEPS 8.1 THRU 8.4

TRANSPORTATION MANAGEMENT PLAN

PHASE IV DETAIL

APPROVED: *Rhonda B. Early*
DocuSigned by: F34CAFSAC8BF48A
 DATE: 9/3/2019

DOCUMENT NOT CONSIDERED FINAL UNLESS ALL SIGNATURES COMPLETED

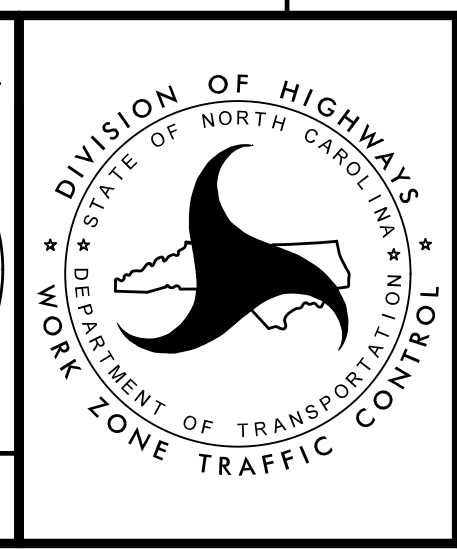

HNTB
HNTB NORTH CAROLINA, P.C.
 343 E. Six Forks Road, Suite 200
 Raleigh, North Carolina 27609
 NC License No: C-1554

I:\07457 PM
 I:\TCP\I-4400BB-t.c.P4adl.dgn
 9/3/2019

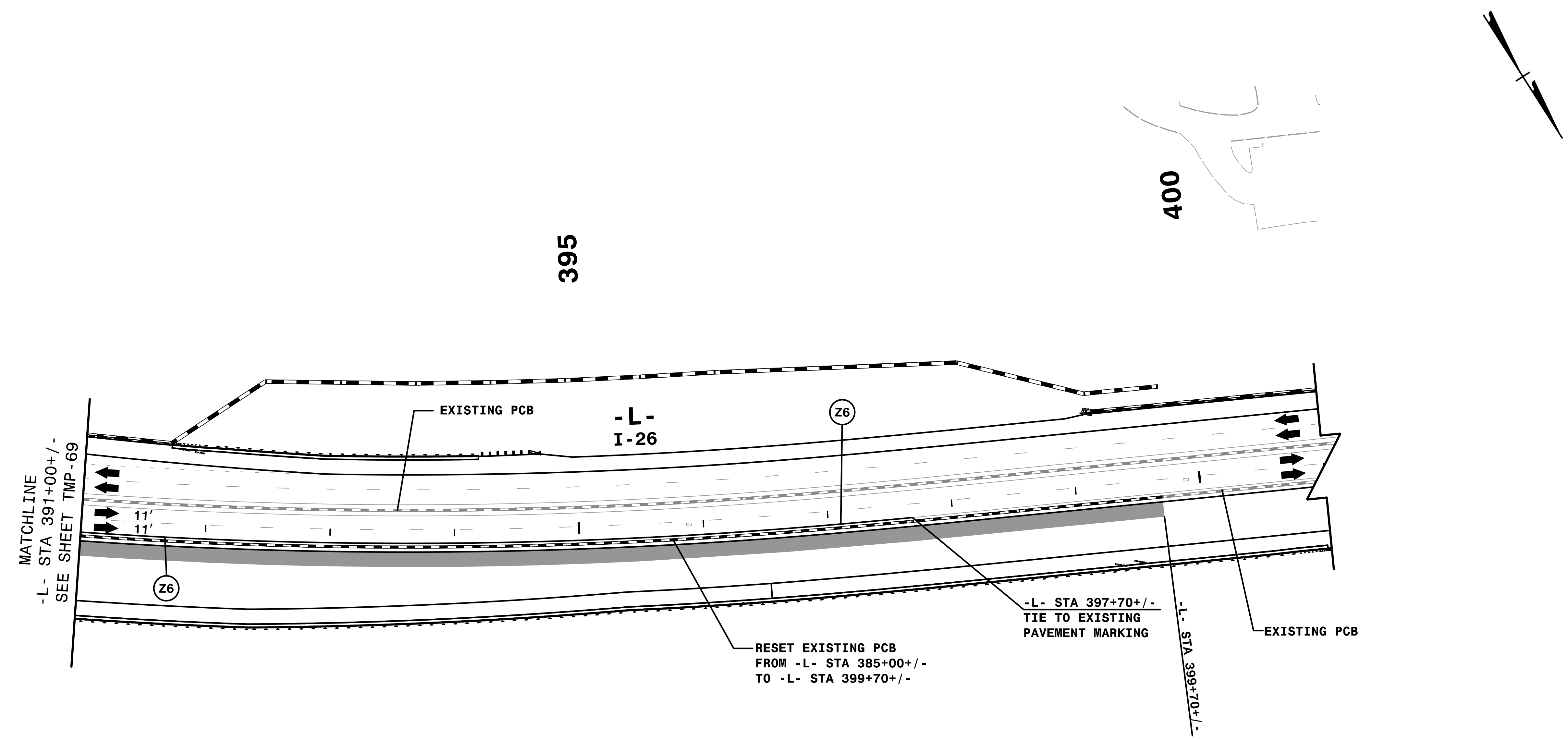

REMOVE CONFLICTING PAVEMENT MARKING.

STEPS 8.1 THRU 8.4

TRANSPORTATION
MANAGEMENT PLAN

PHASE IV
DETAIL

APPROVED: *Rhonda B. Early*
DocuSigned by:
F34CAFAC8BF46A

DATE: 9/3/2019

SEAL
 NORTH CAROLINA
 PROFESSIONAL
 ENGINEERS
 RHONDA B. EARLY
 023521

**DOCUMENT NOT CONSIDERED FINAL
 UNLESS ALL SIGNATURES COMPLETED**

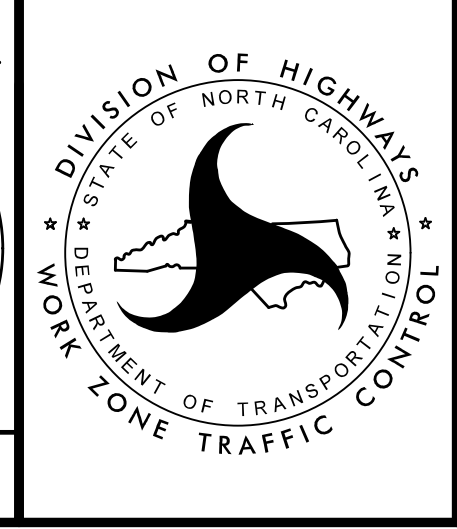

HNTB HNTB NORTH CAROLINA, P.C.
 343 E. Six Forks Road, Suite 200
 Raleigh, North Carolina 27609
 NC License No: C-1554

I:\08\03 PM
 \TC\N\I-4400BB.t.c.P4ad2.dgn
 9/3/2019

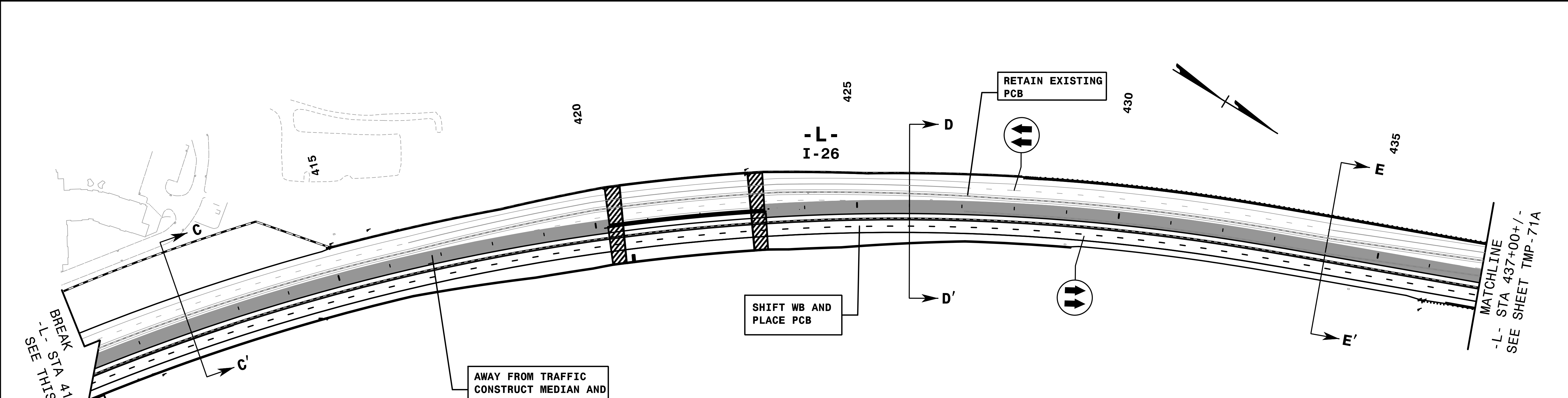
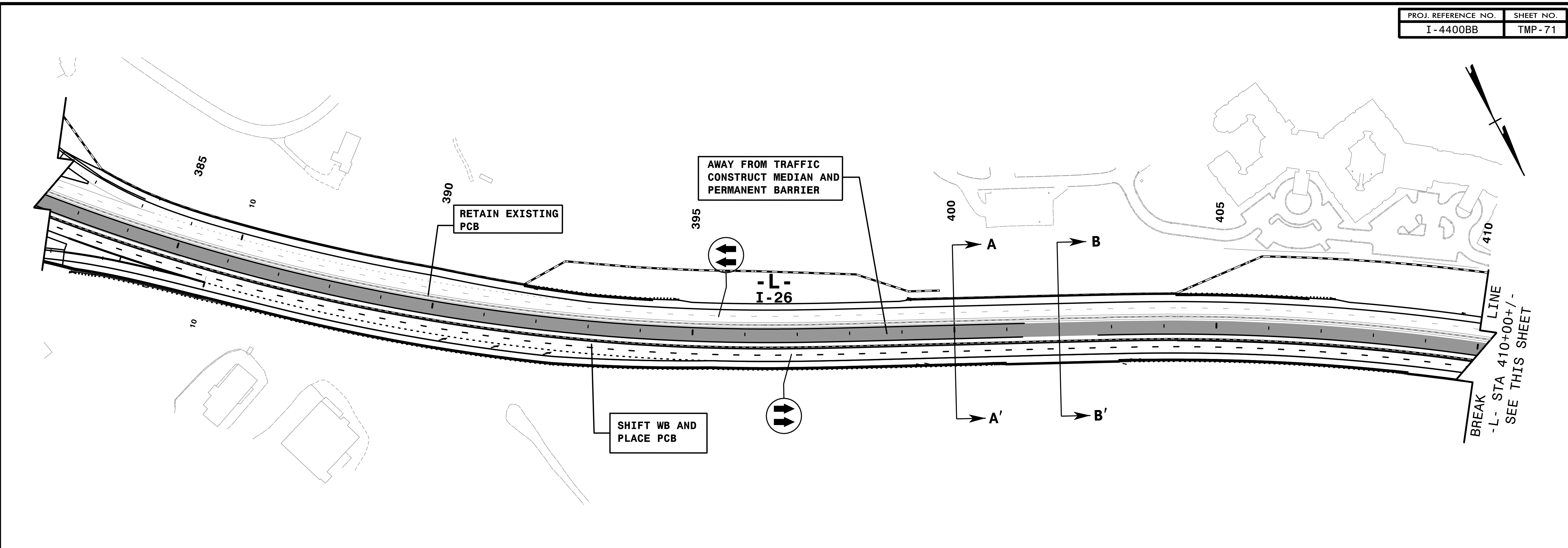

11/14/20 PM
...:\TrafficControl\TCP\0_V\p5_L.dgn
9/3/2019

BREAK
-L- STA 410+00+/-
SEE THIS SHEET

MATCHLINE
-L- STA 437+00+/-
SEE SHEET TMP-71A

HNTB HNTB NORTH CAROLINA, P.C.
343 E. SIX FORKS ROAD, SUITE 200
RALEIGH, NORTH CAROLINA 27609
NC LICENSE NO: C-1554

APPROVED: *Rhonda B. Early*
DATE: 9/3/2019

DocuSigned by:
Rhonda B. Early
F34CAF5AC8BF48A

NORTH CAROLINA
PROFESSIONAL
SEAL
023521
ENGINEER
RHONDA B. EARLY

**DOCUMENT NOT CONSIDERED FINAL
UNLESS ALL SIGNATURES COMPLETED**

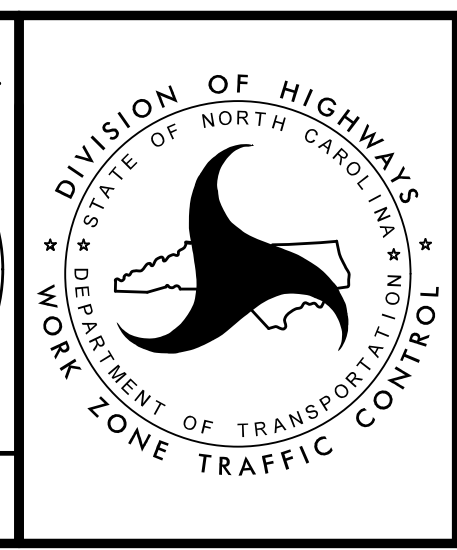

TRANSPORTATION
MANAGEMENT PLAN

PHASE V
OVERVIEW

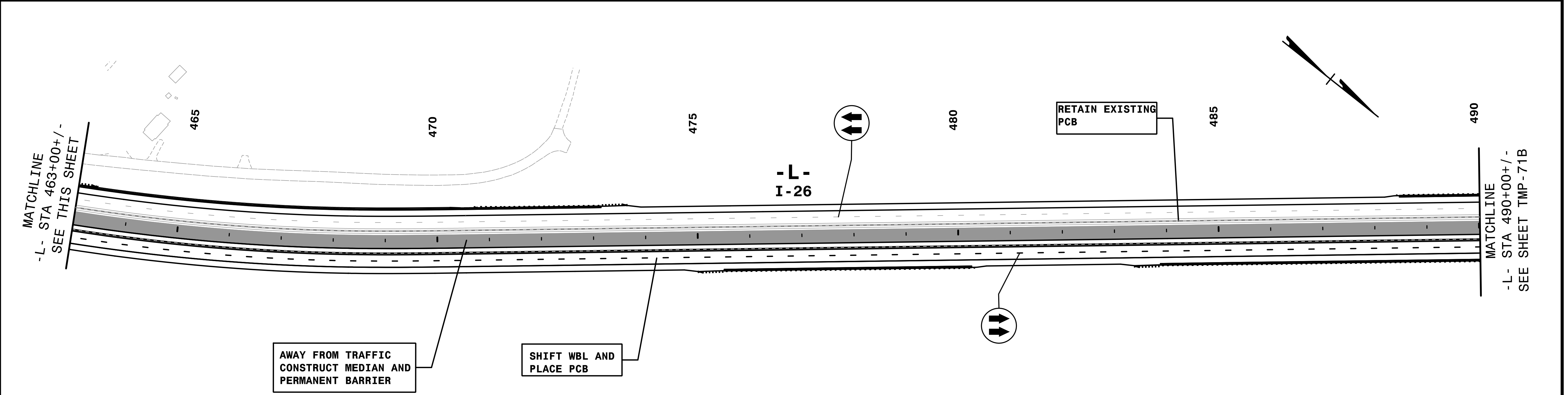
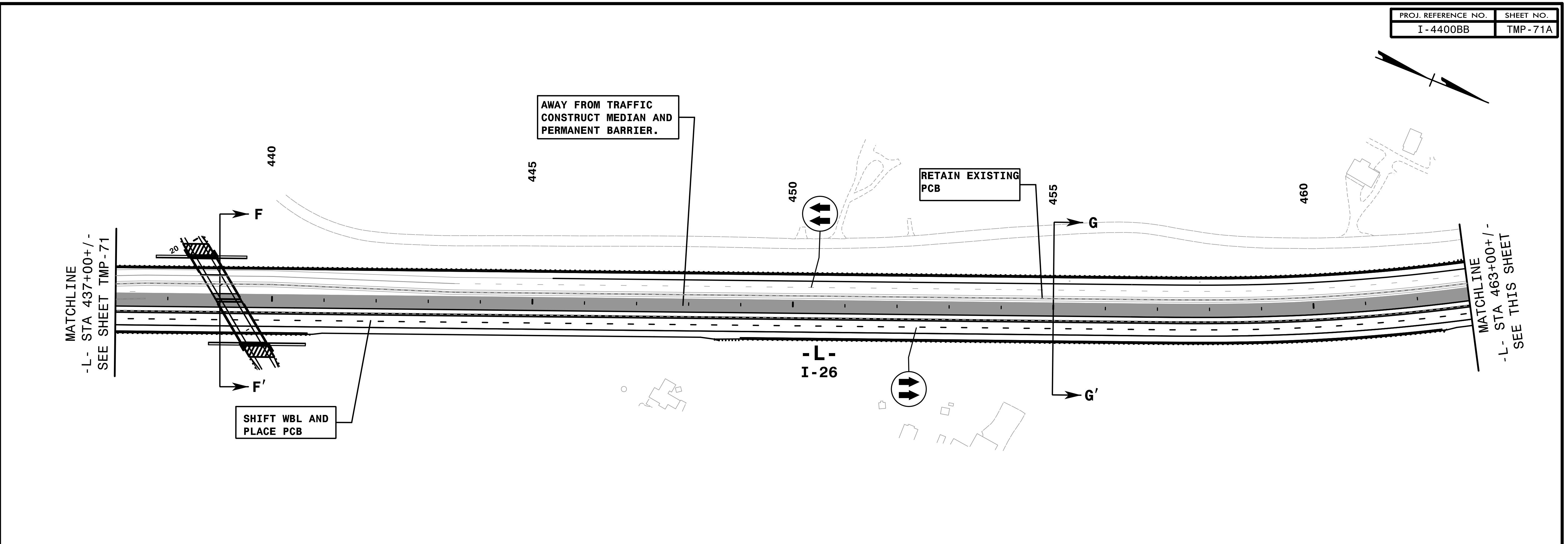

11:46 PM
\\tratt\office\control\TCP\OV_P5_2.dgn
9/3/2019

HNTB
 HNTB NORTH CAROLINA, P.C.
 343 E. Six Forks Road, Suite 200
 Raleigh, North Carolina 27609
 NC License No: C-1554

APPROVED: *Rhonda B. Early*
FS34CAF5AC8BF48A
 DATE: 9/3/2019

SEAL
 NORTH CAROLINA
 PROFESSIONAL ENGINEER
 RHONDA B. EARLY
 023521

**DOCUMENT NOT CONSIDERED FINAL
 UNLESS ALL SIGNATURES COMPLETED**



TRANSPORTATION
 MANAGEMENT PLAN

PHASE V
 OVERVIEW

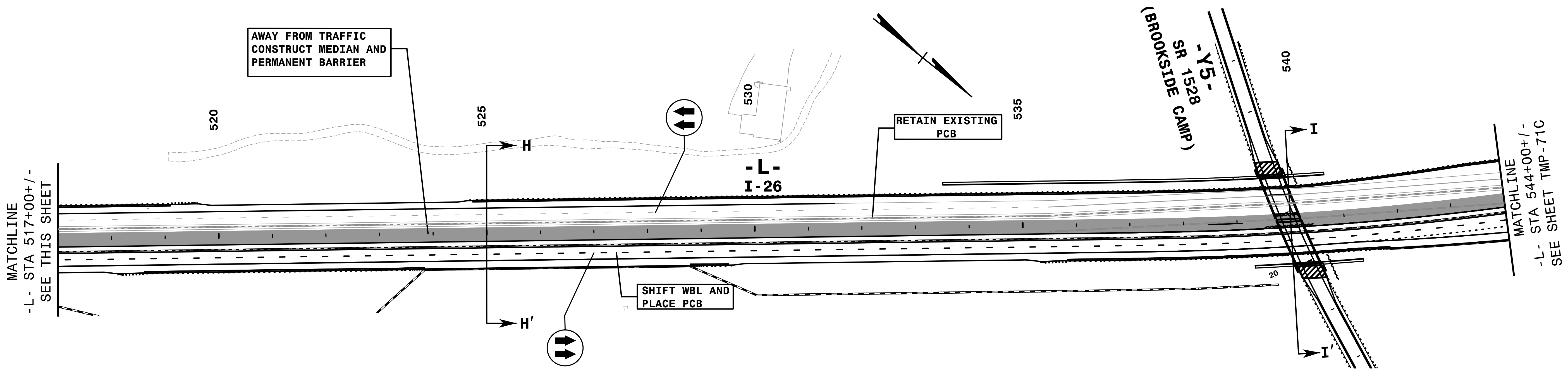
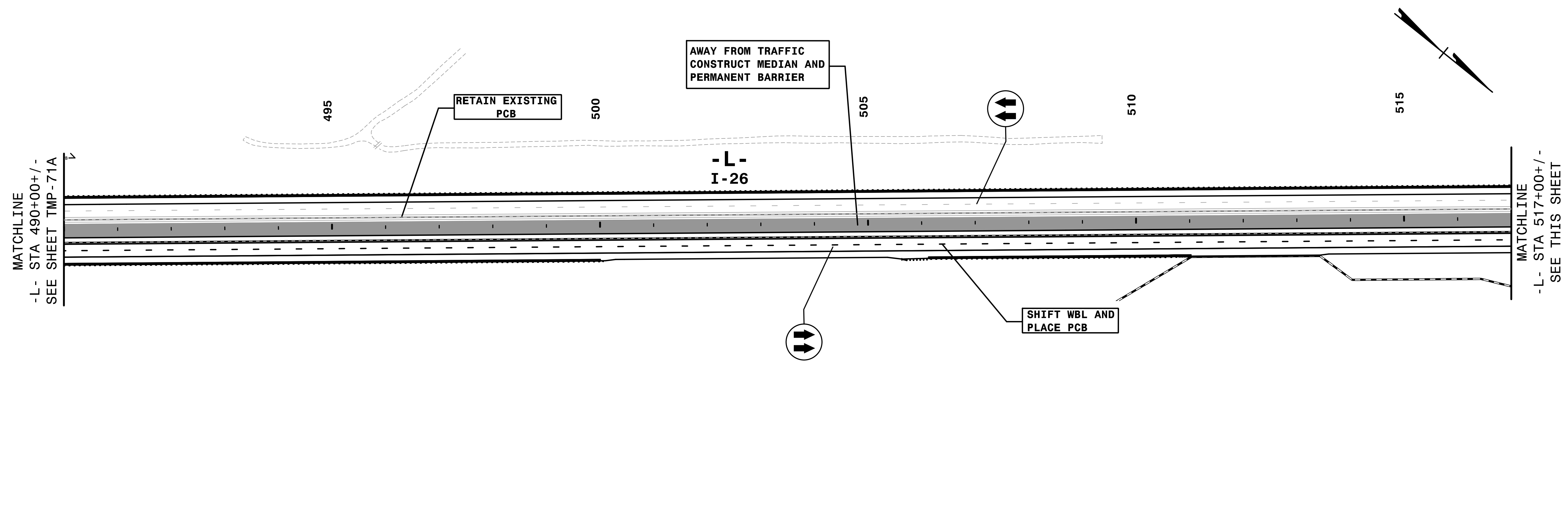

I:\2-03_PM\...I:\office\Control\TCP\OV_p5_3.dgn
9/3/2019

HNTB
 HNTB NORTH CAROLINA, P.C.
 343 E. Six Forks Road, Suite 200
 Raleigh, North Carolina 27609
 NC License No: C-1554

APPROVED: *Rhonda B. Early*
 DATE: 9/3/2019
 NORTH CAROLINA PROFESSIONAL ENGINEER
 SEAL 023521
 RHONDA B. EARLY

**DOCUMENT NOT CONSIDERED FINAL
 UNLESS ALL SIGNATURES COMPLETED**

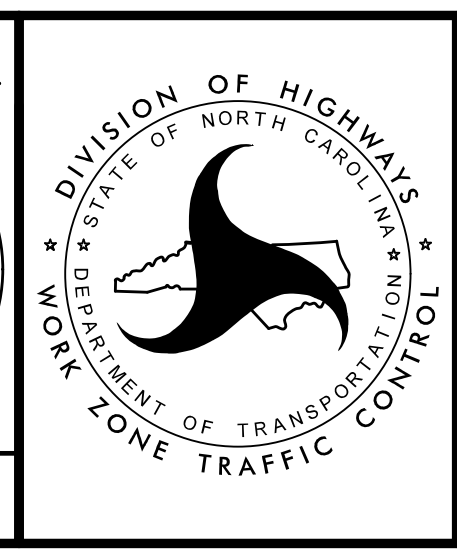

TRANSPORTATION
 MANAGEMENT PLAN

PHASE V
 OVERVIEW

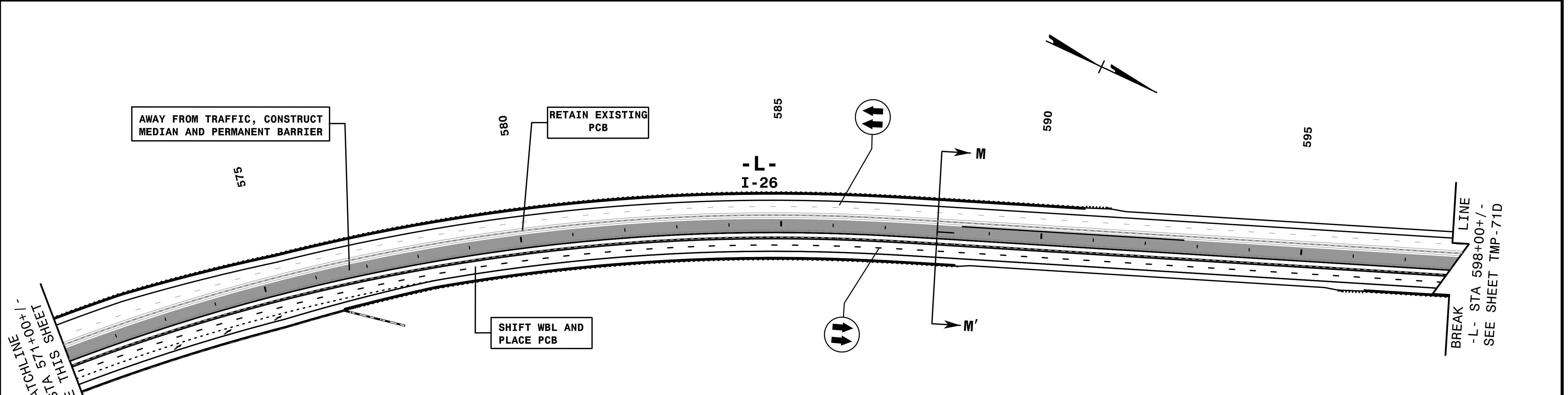
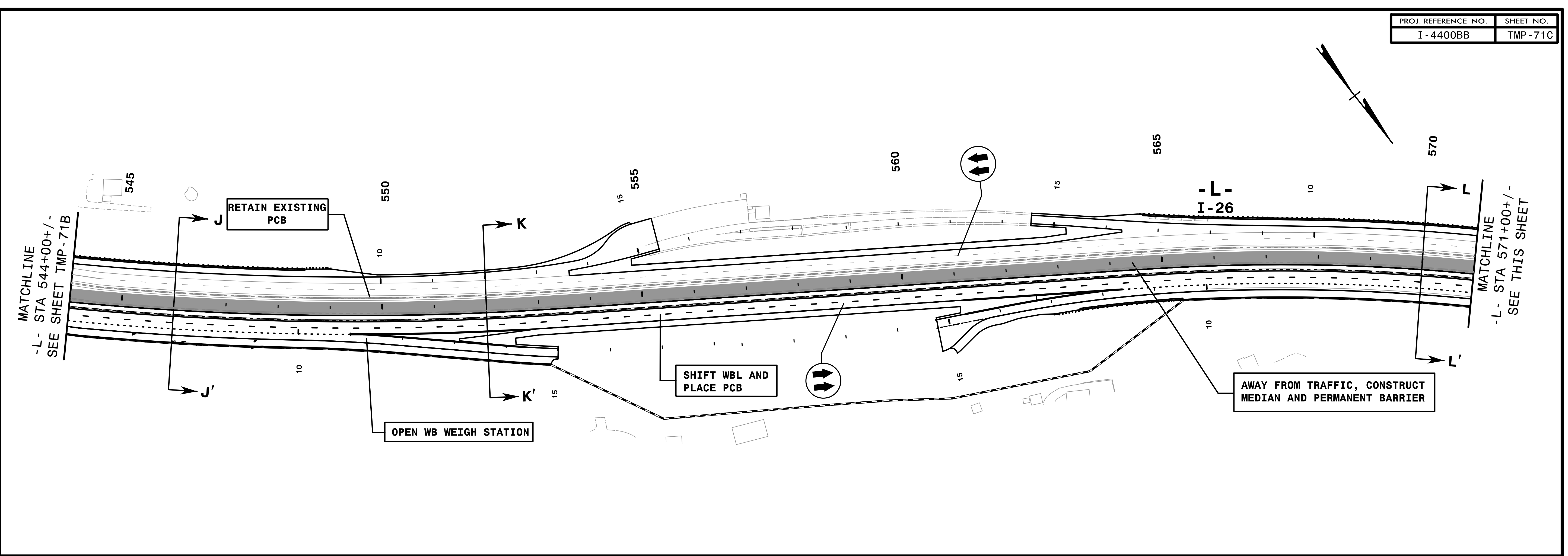

11:22 PM
\\T:\aff\Control\TCP\OV_P5_4.dgn
9/3/2019

HNTB
 HNTB NORTH CAROLINA, P.C.
 343 E. SIX FORKS ROAD, SUITE 200
 RALEIGH, NORTH CAROLINA 27609
 NC LICENSE NO: C-1554

APPROVED: *Rhonda B. Early*
 DATE: 9/3/2019
 NORTH CAROLINA PROFESSIONAL ENGINEERS
 SEAL
 023521
 RHONDA B. EARLY

**DOCUMENT NOT CONSIDERED FINAL
 UNLESS ALL SIGNATURES COMPLETED**

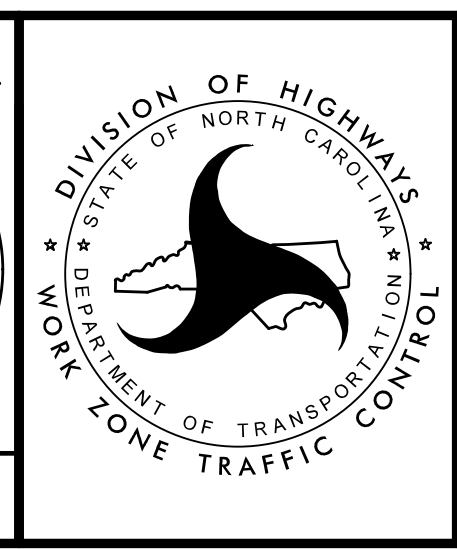

TRANSPORTATION
 MANAGEMENT PLAN

PHASE V
 OVERVIEW

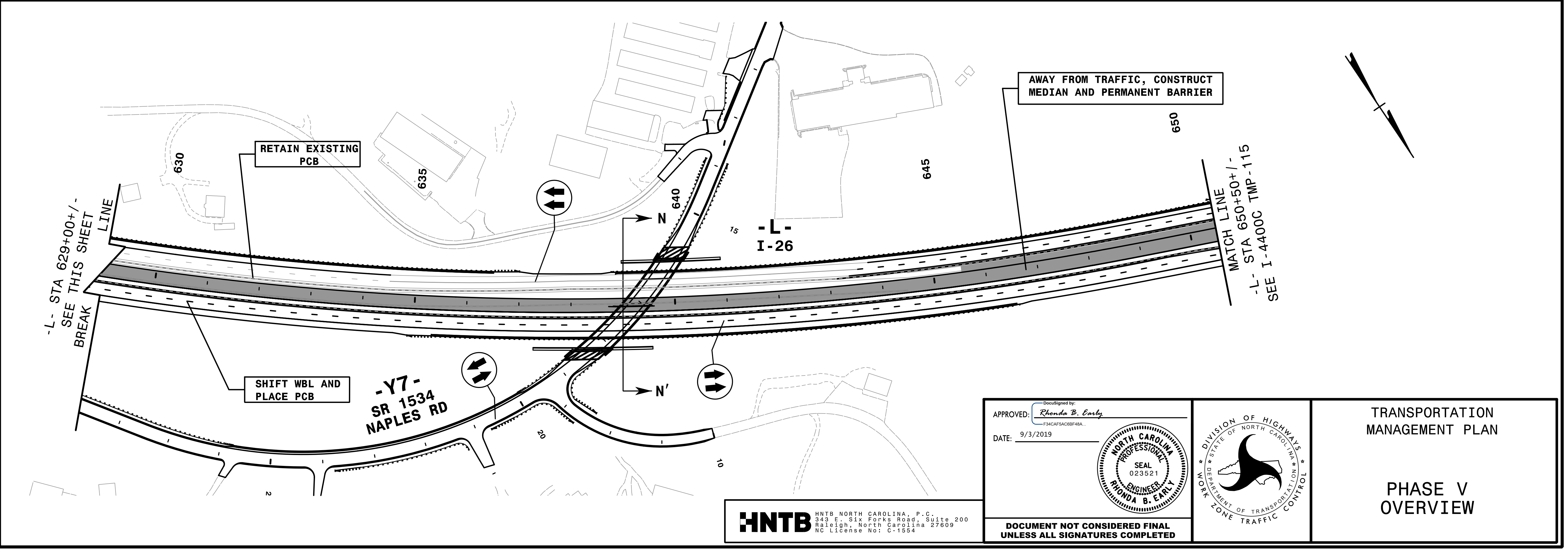
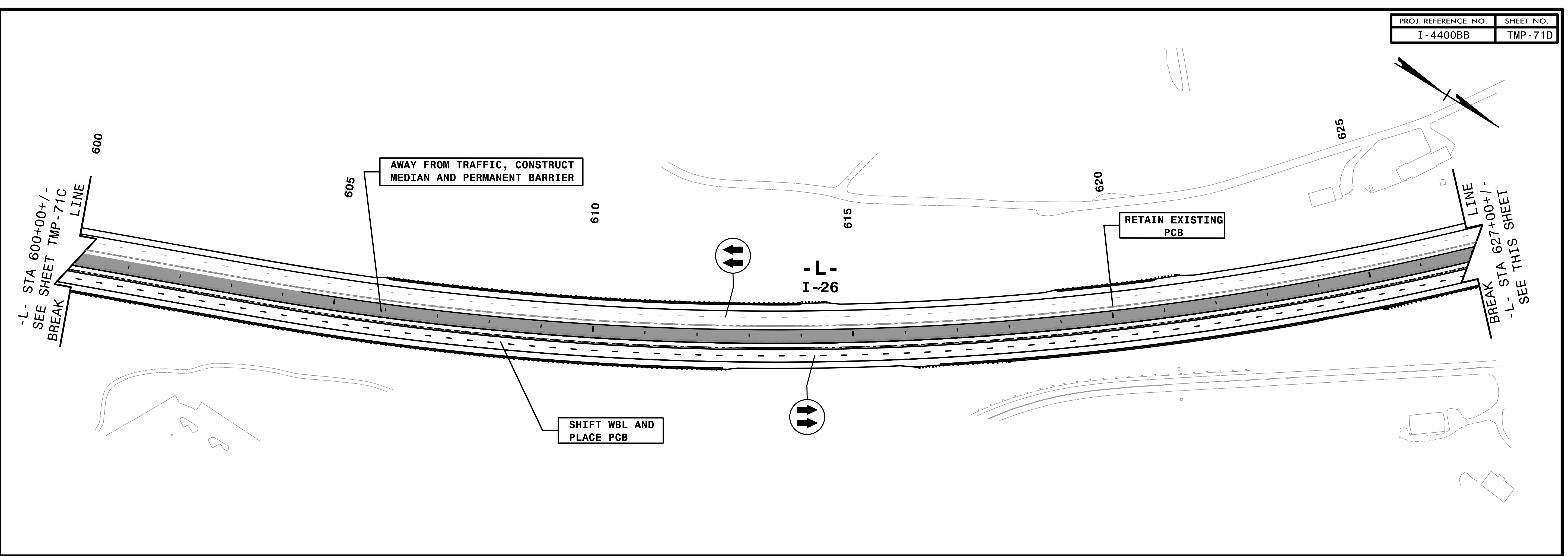

I:\246 PM
...TrafficControl\TCP\OV_P5_5.dgn
9/3/2019

HNTB
 HNTB NORTH CAROLINA, P.C.
 343 E. Six Forks Road, Suite 200
 Raleigh, North Carolina 27609
 NC License No: C-1554

APPROVED: *Rhonda B. Early*
 DATE: 9/3/2019
 DOCUMENT NOT CONSIDERED FINAL
 UNLESS ALL SIGNATURES COMPLETED

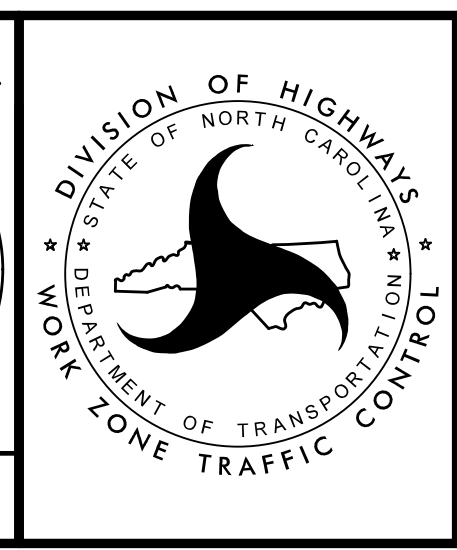
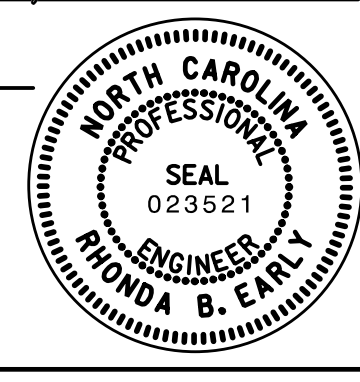

TRANSPORTATION
 MANAGEMENT PLAN
 PHASE V
 OVERVIEW

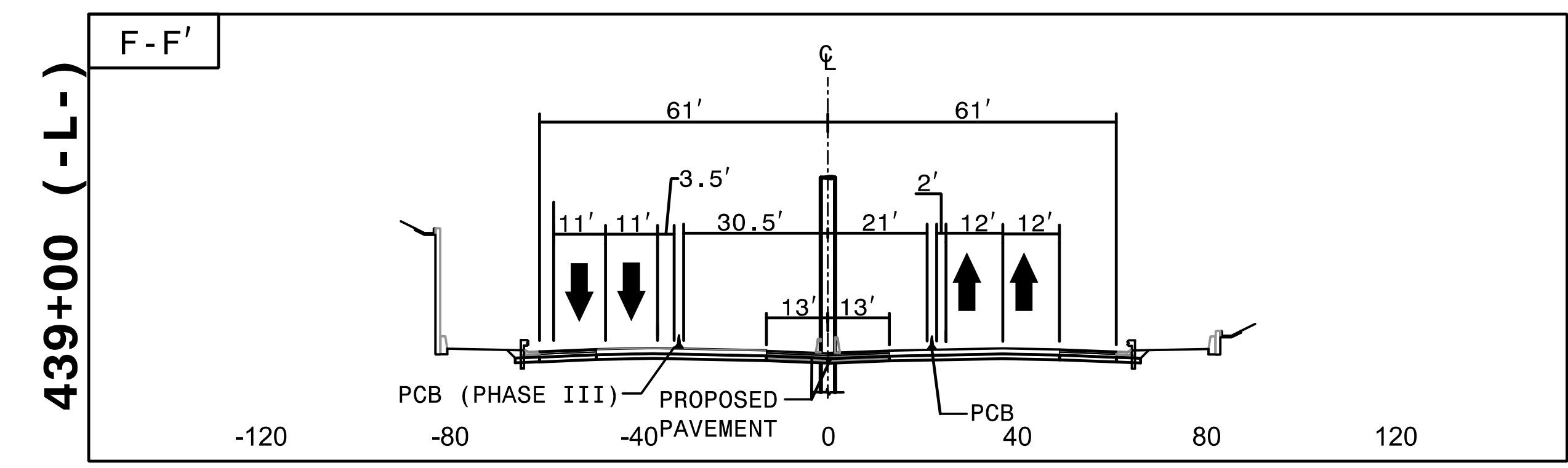
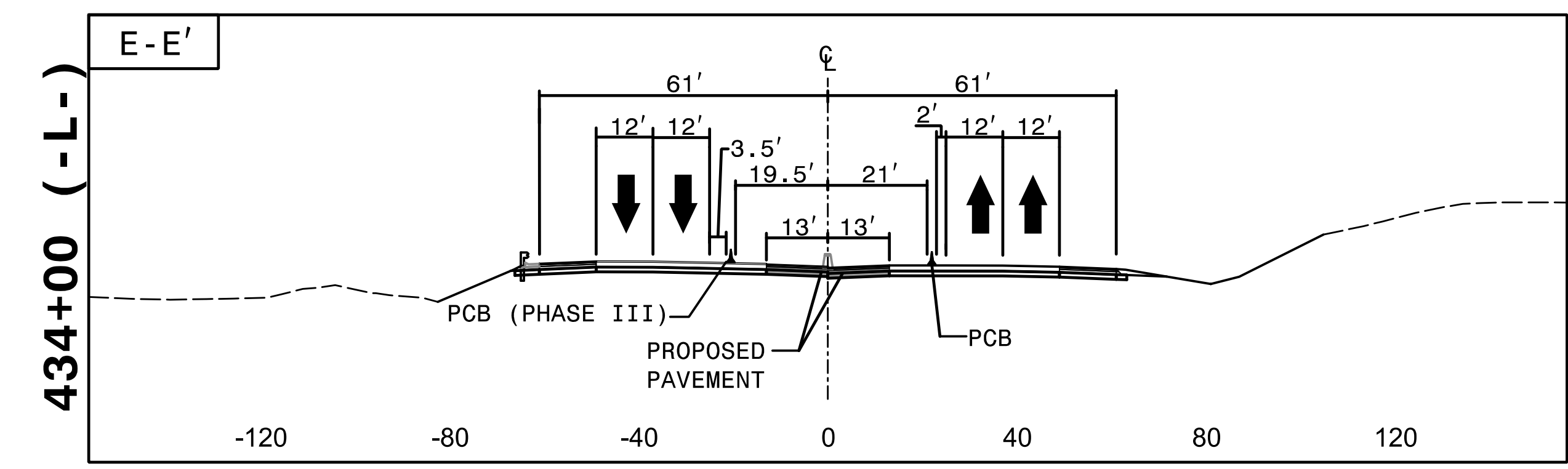
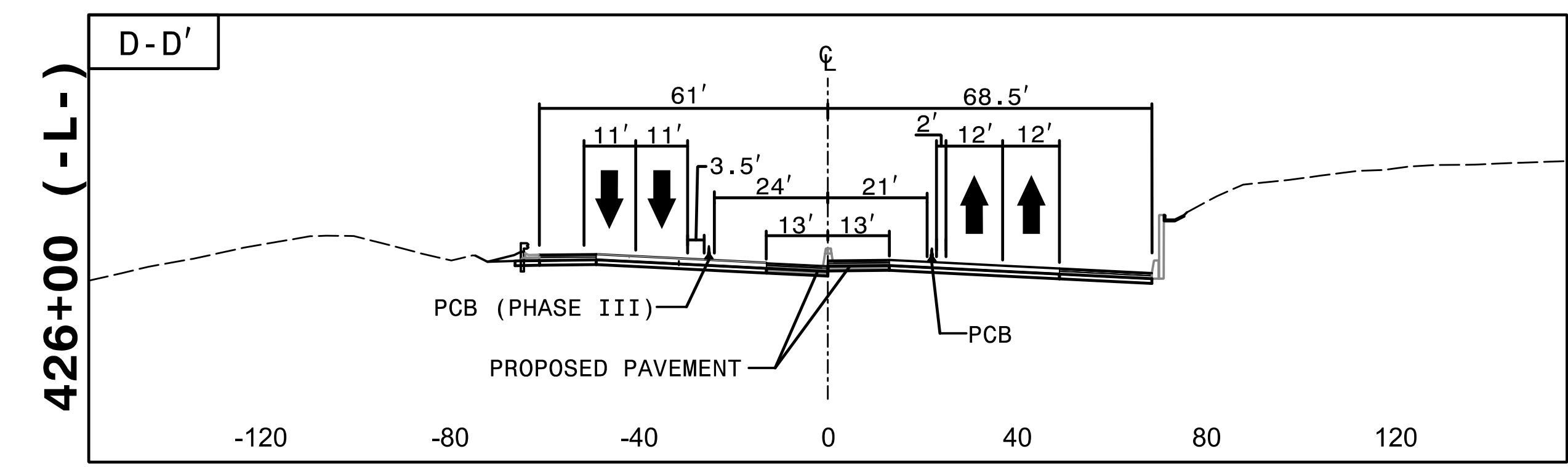
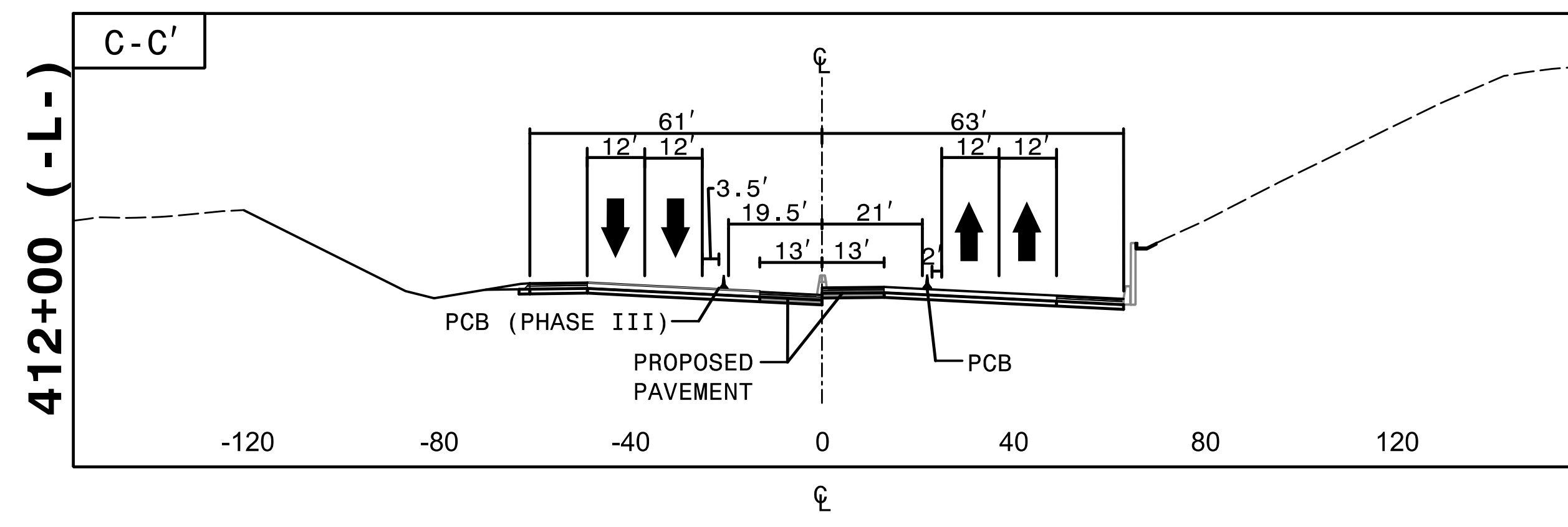
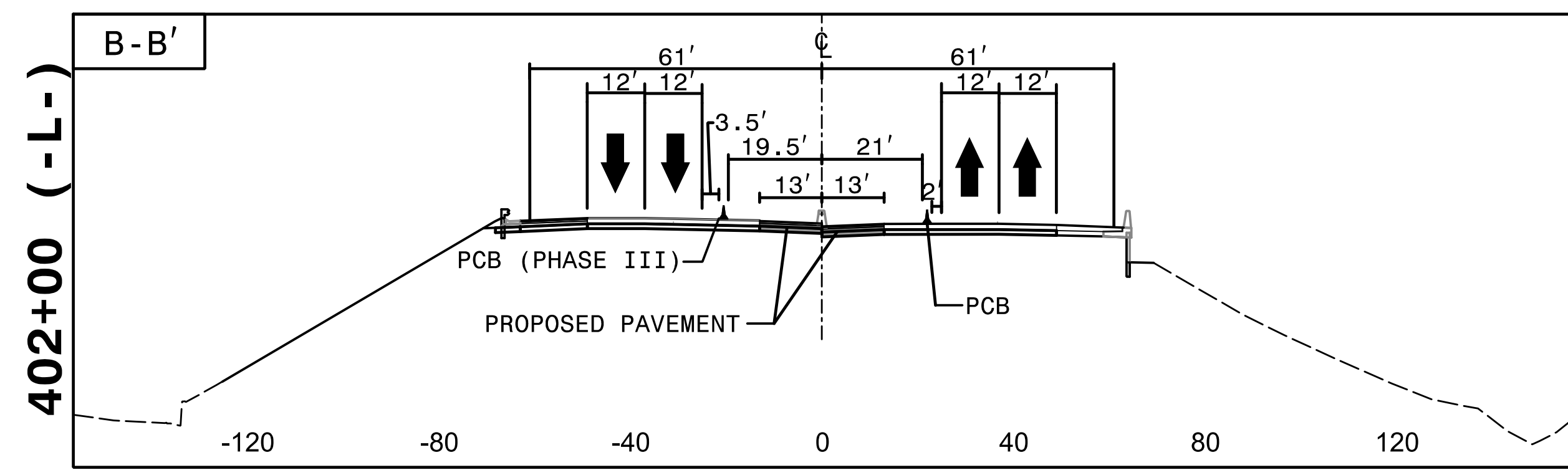
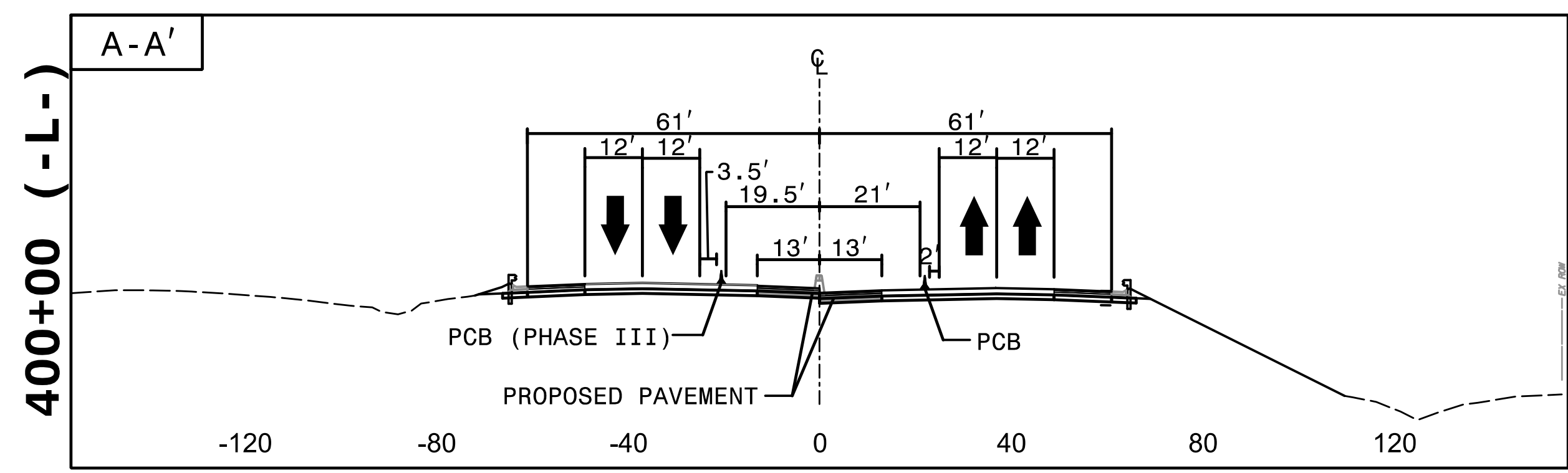

I:\317_PM\1\CP\4400BB_fc_p5 CUTS.dgn
9/3/2019

HNTB
HNTB NORTH CAROLINA, P.C.
343 E. Six Forks Road, Suite 200
Raleigh, North Carolina 27609
NC License No: C-1554

APPROVED: *Rhonda B. Early*
DATE: 9/3/2019

NORTH CAROLINA
PROFESSIONAL
SEAL
023521
ENGINEER
RHONDA B. EARLY

**DOCUMENT NOT CONSIDERED FINAL
UNLESS ALL SIGNATURES COMPLETED**

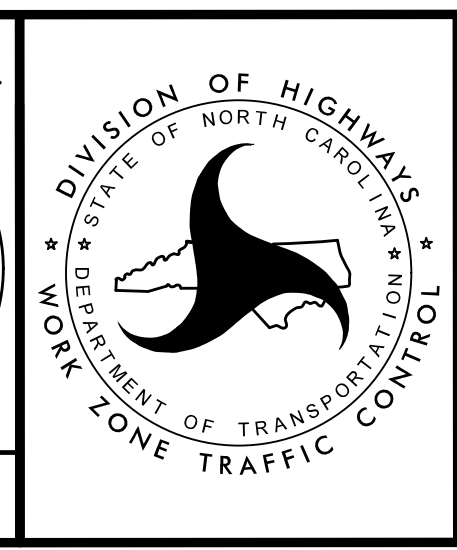

TRANSPORTATION
MANAGEMENT PLAN

**PHASE V
CUT SECTIONS**

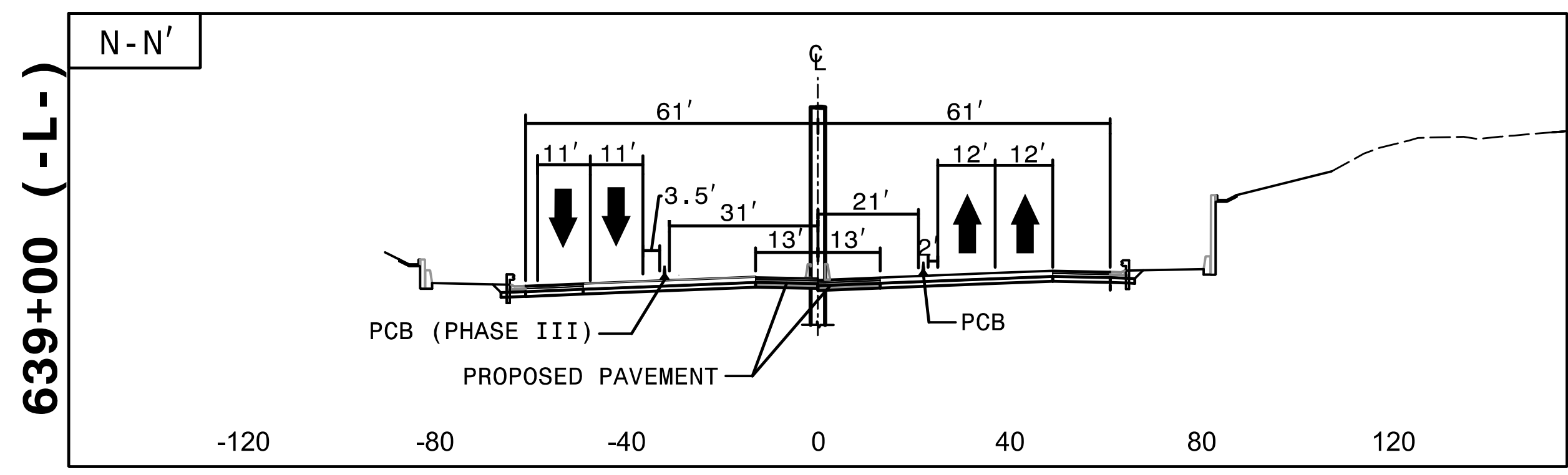
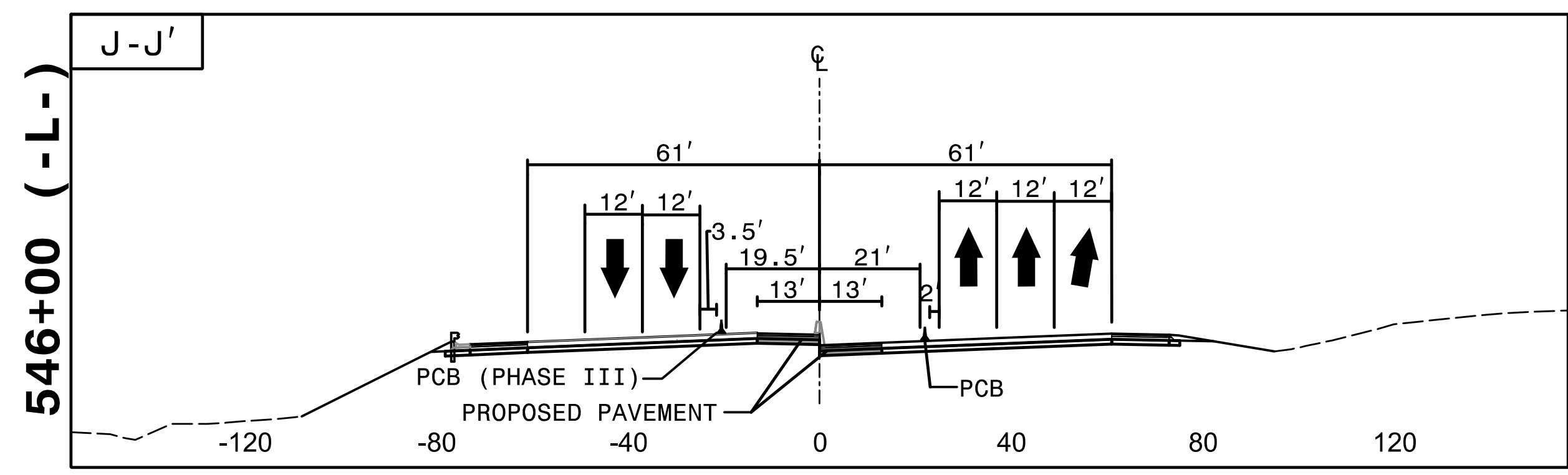
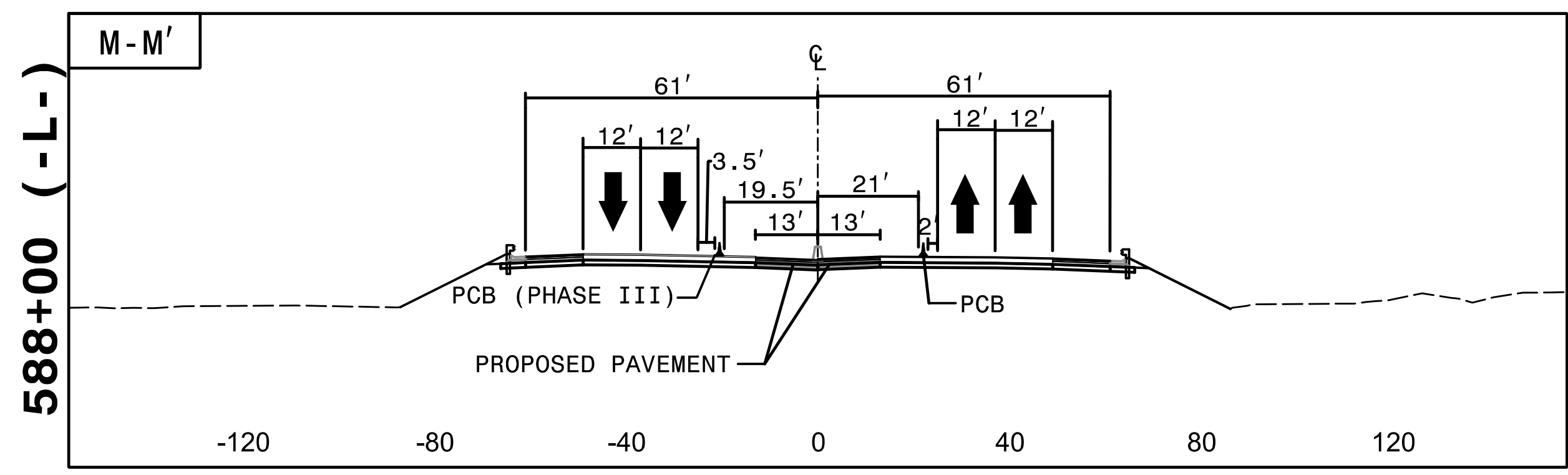
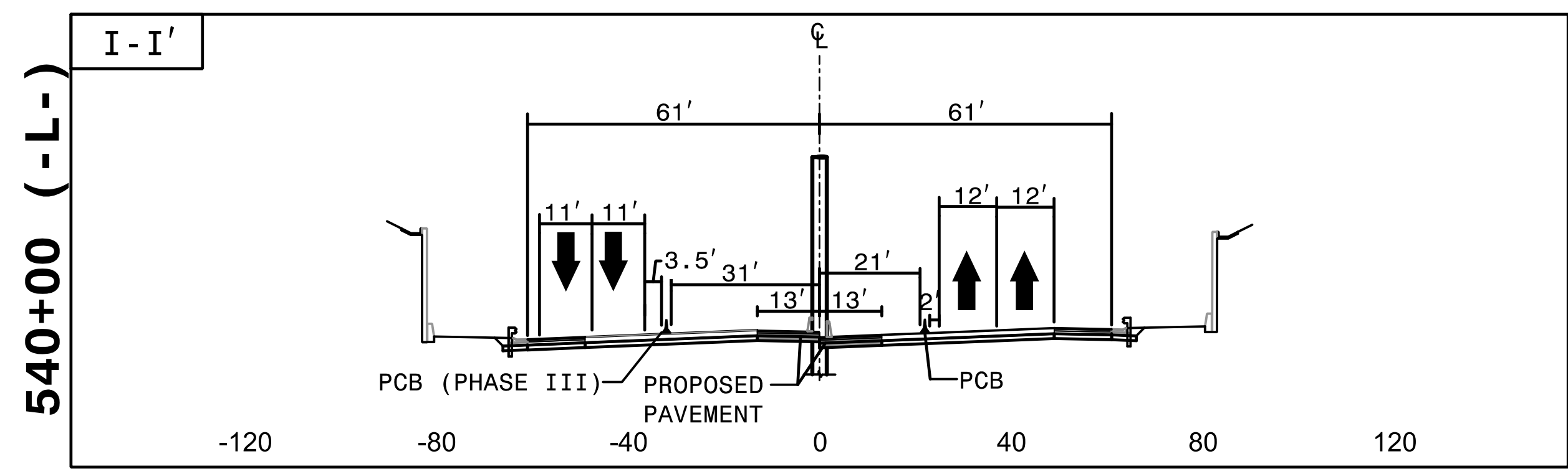
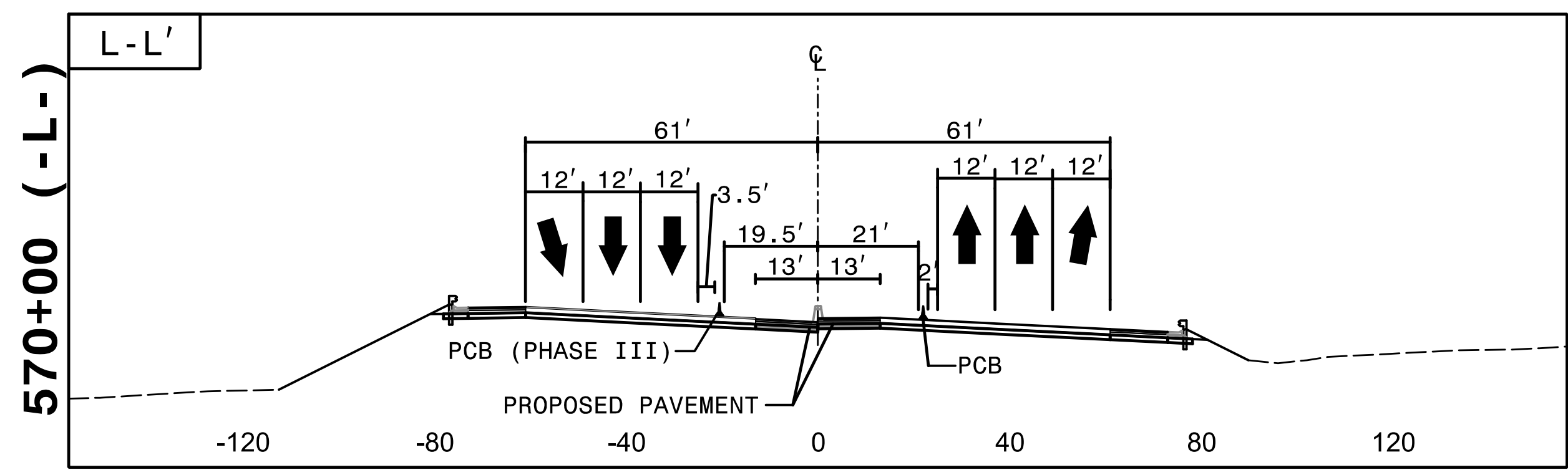
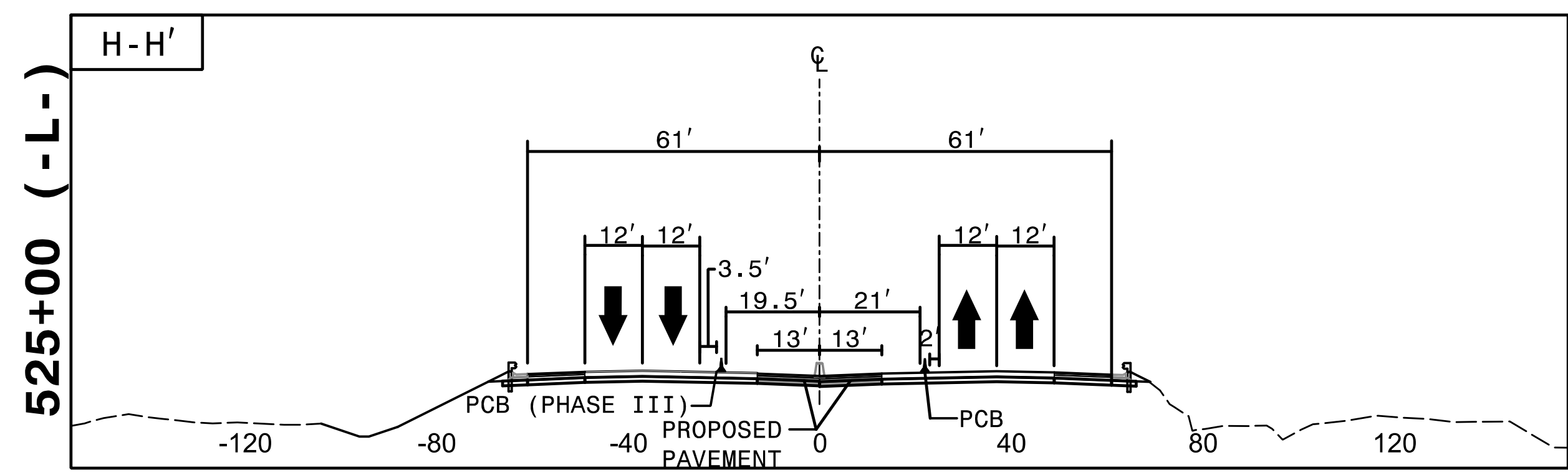
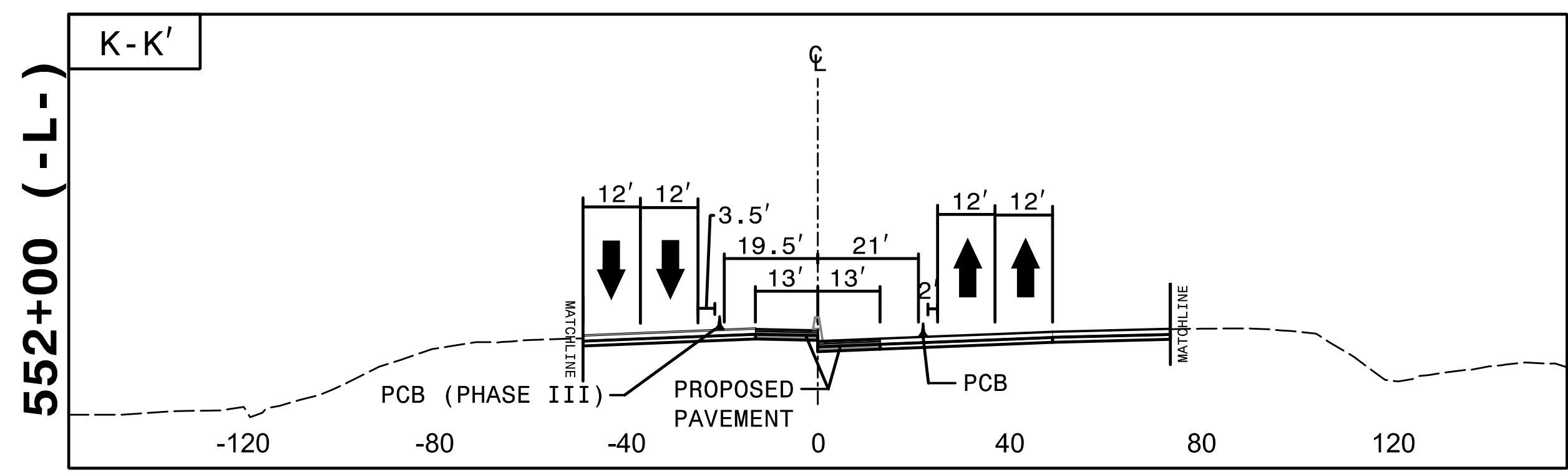
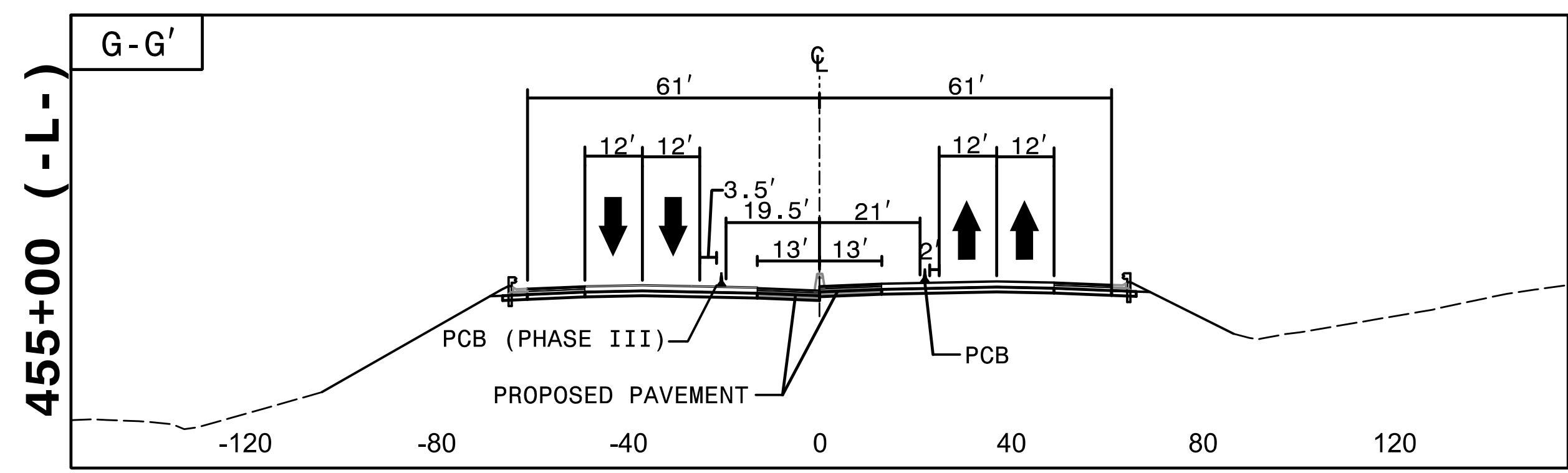

I:\3:25 PM\14400BB_fc_p5 CUTS.dgn
9/3/2019

HNTB
 HNTB NORTH CAROLINA, P.C.
 343 E. Six Forks Road, Suite 200
 Raleigh, North Carolina 27609
 NC License No: C-1554

APPROVED: *Rhonda B. Early*
 DATE: 9/3/2019
 NORTH CAROLINA PROFESSIONAL ENGINEER
 SEAL 023521
 RHONDA B. EARLY

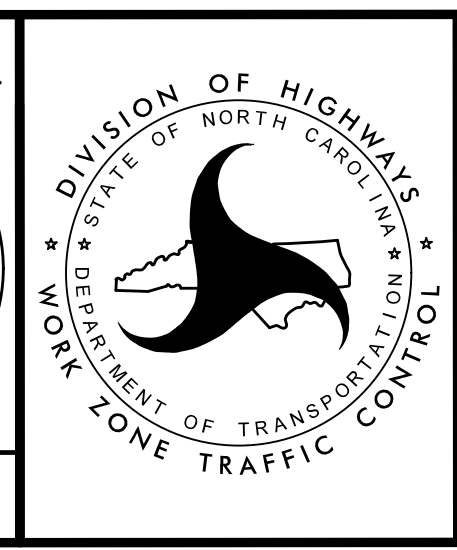

TRANSPORTATION
 MANAGEMENT PLAN
 PHASE V
 CUT SECTIONS

DOCUMENT NOT CONSIDERED FINAL
UNLESS ALL SIGNATURES COMPLETED

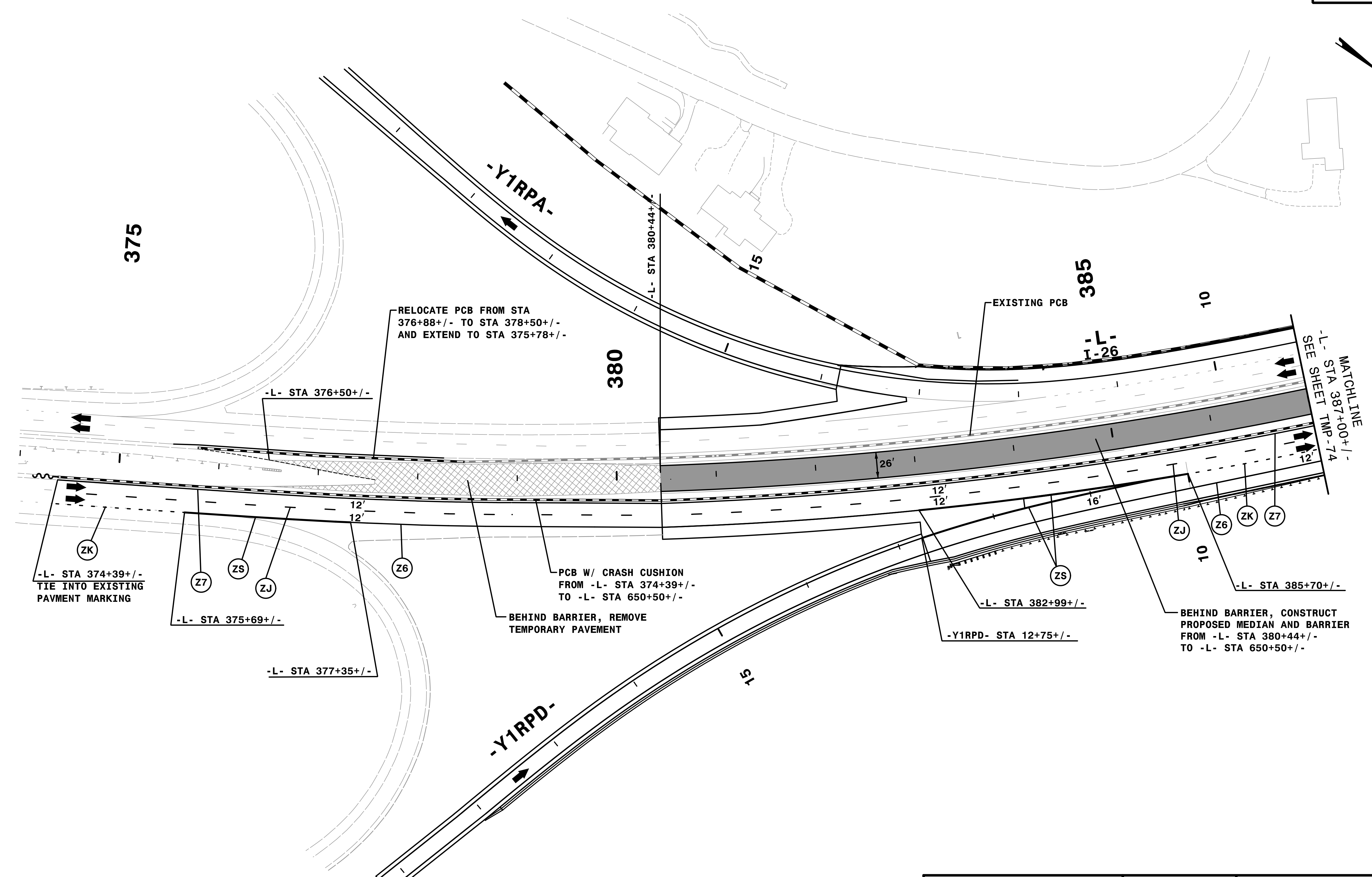

REMOVE CONFLICTING PAVEMENT MARKING.

14:33:39_PM
I:\CPN\I-4400BB.t.c.P5D\dgn
9/3/2019

HNTB
 HNTB NORTH CAROLINA, P.C.
 343 E. Six Forks Road, Suite 200
 Raleigh, North Carolina 27609
 NC License No: C-1554

APPROVED: *Rhonda B. Early*
DocuSigned by:
Rhonda B. Early
F34CAF5AC0BF48A

DATE: 9/3/2019

SEAL
 NORTH CAROLINA
 PROFESSIONAL ENGINEER
 023521
 RHONDA B. EARLY

**DOCUMENT NOT CONSIDERED FINAL
 UNLESS ALL SIGNATURES COMPLETED**

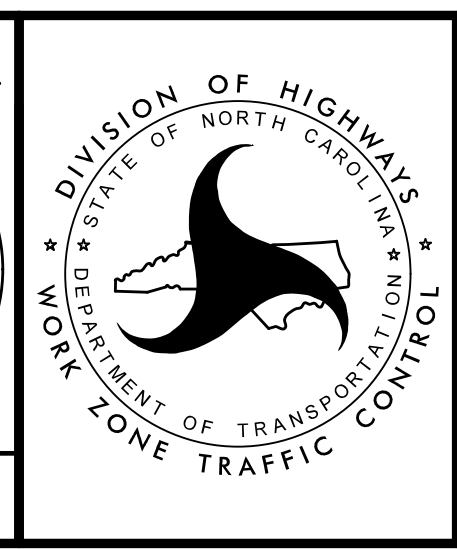

TRANSPORTATION
 MANAGEMENT PLAN

PHASE V
 DETAIL

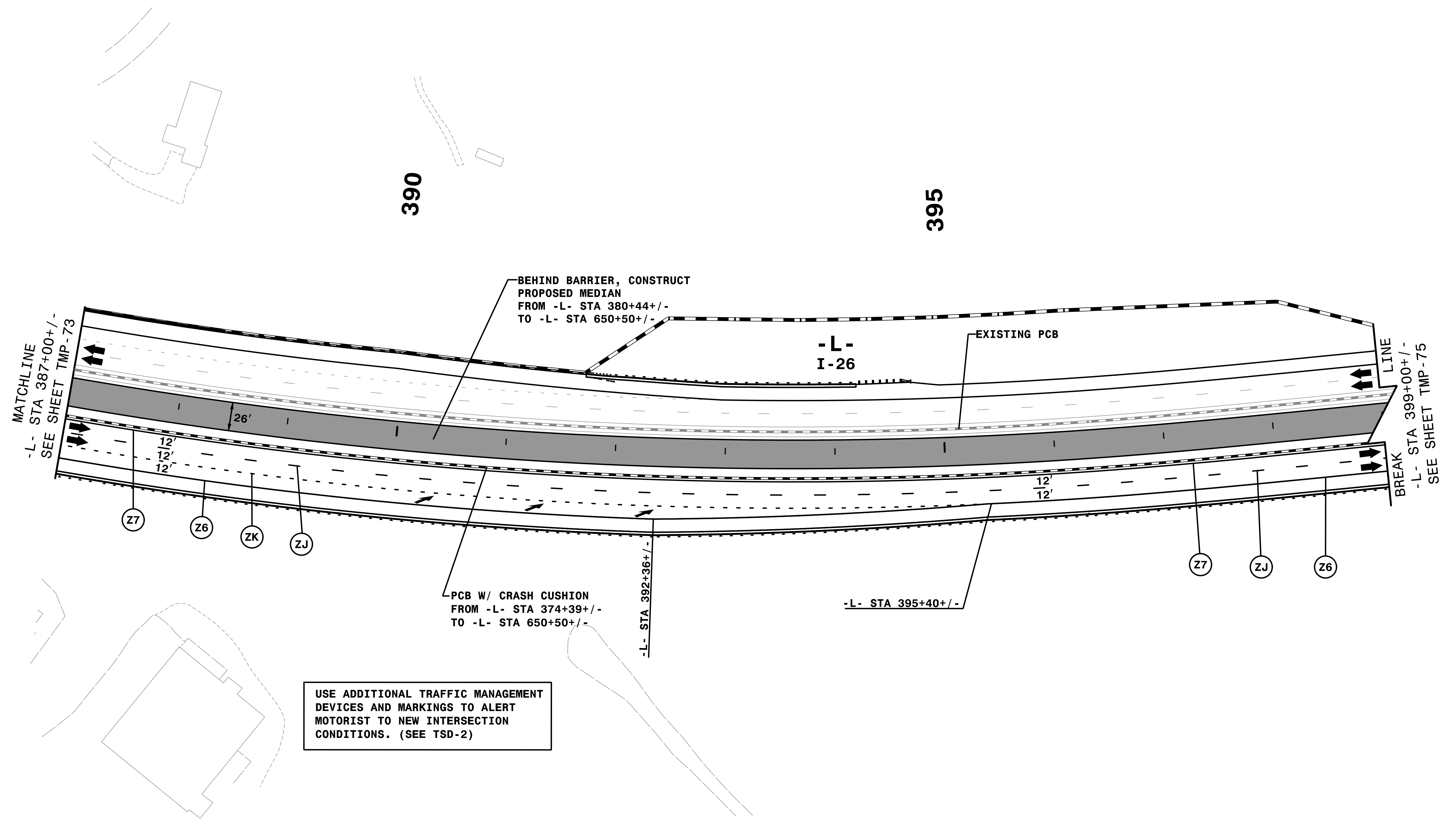
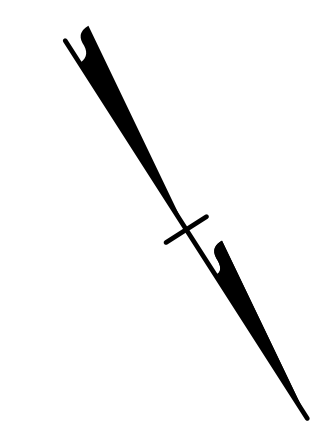

REMOVE CONFLICTING PAVEMENT MARKING.

1:5:47 PM
 I:\CP\I-4400BB.t.c. P5D2.dgn
 9/3/2019

HNTB
 HNTB NORTH CAROLINA, P.C.
 343 E. Six Forks Road, Suite 200
 Raleigh, North Carolina 27609
 NC License No: C-1554

APPROVED: *Rhonda B. Early*
 DATE: 9/3/2019

DocuSigned by:
 Rhonda B. Early
 F34CAF5AC8BF48A

PROFESSIONAL ENGINEER SEAL
 NORTH CAROLINA
 023521
 RHONDA B. EARLY

DOCUMENT NOT CONSIDERED FINAL UNLESS ALL SIGNATURES COMPLETED

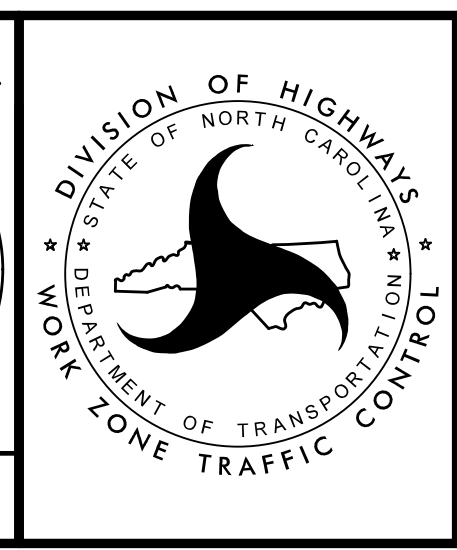

TRANSPORTATION
 MANAGEMENT PLAN

PHASE V
 DETAIL

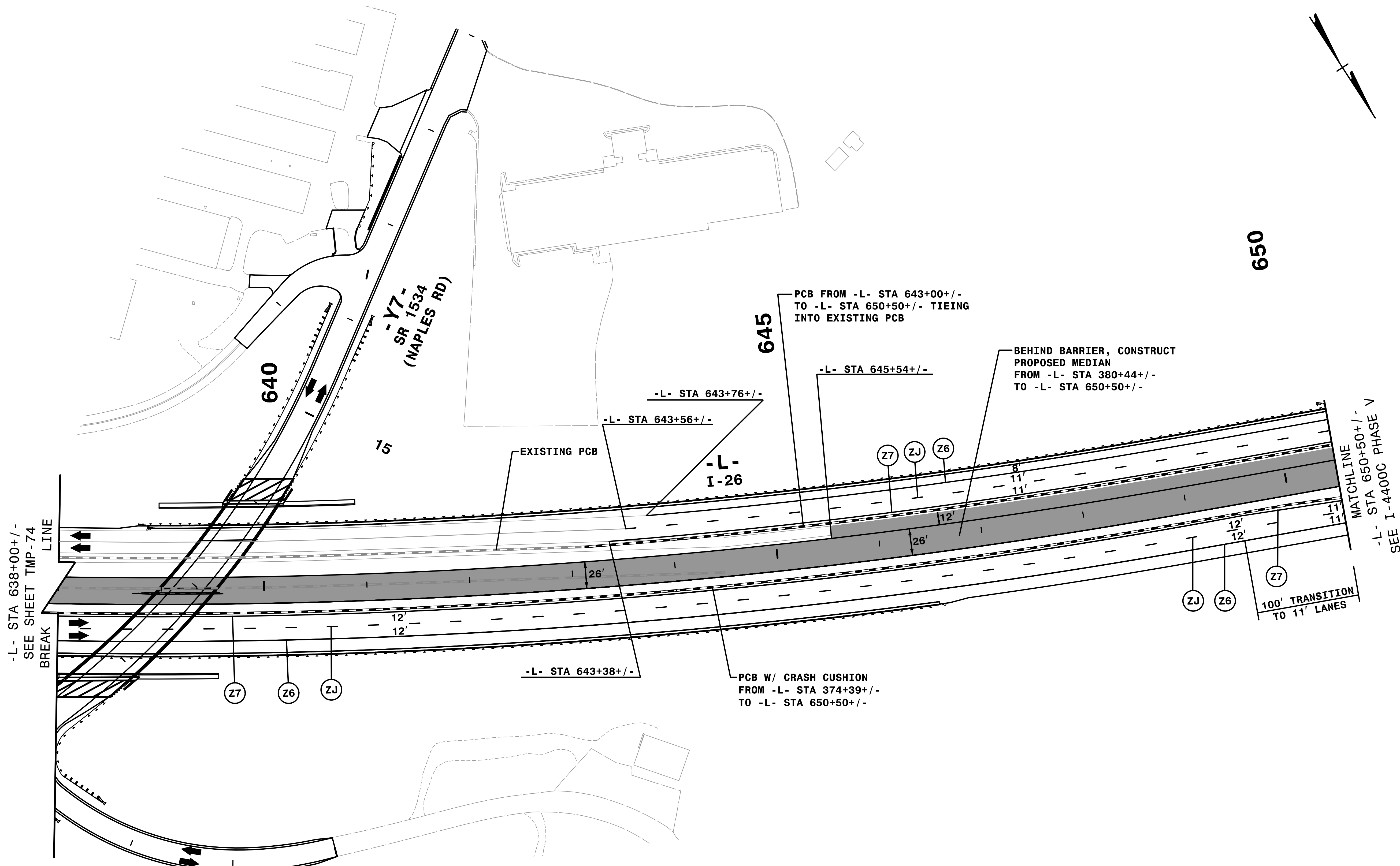

650

-L- STA 638+00+/-
SEE SHEET TMP-74
BREAK

LINE

REMOVE CONFLICTING PAVEMENT MARKING.

I:\3555_PM
I-4400BB.tcd
9/3/2019

HNTB
 HNTB NORTH CAROLINA, P.C.
 343 E. Six Forks Road, Suite 200
 Raleigh, North Carolina 27609
 NC License No: C-1554

APPROVED: *Rhonda B. Early*
 DATE: 9/3/2019
 NORTH CAROLINA PROFESSIONAL ENGINEERS
 SEAL
 023521
 RHONDA B. EARLY

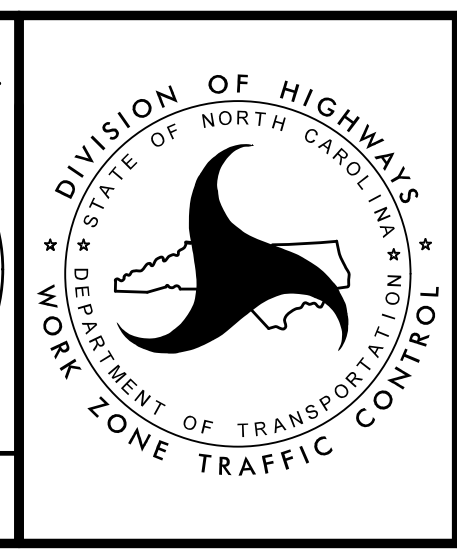

TRANSPORTATION
 MANAGEMENT PLAN

PHASE V
 DETAIL

DOCUMENT NOT CONSIDERED FINAL
UNLESS ALL SIGNATURES COMPLETED