

**This electronic collection of documents is provided  
for the convenience of the user  
and is Not a Certified Document –**

**The documents contained herein were originally issued  
and sealed by the individuals whose names and license  
numbers appear on each page, on the dates appearing  
with their signature on that page.**

**This file or an individual page  
shall not be considered a certified document.**

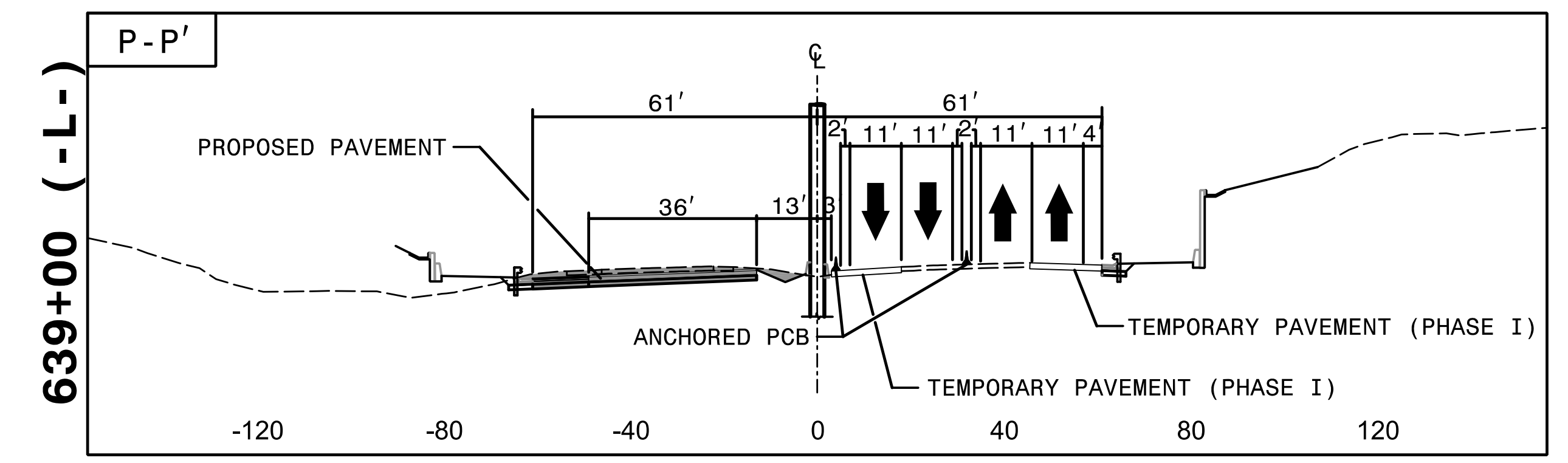
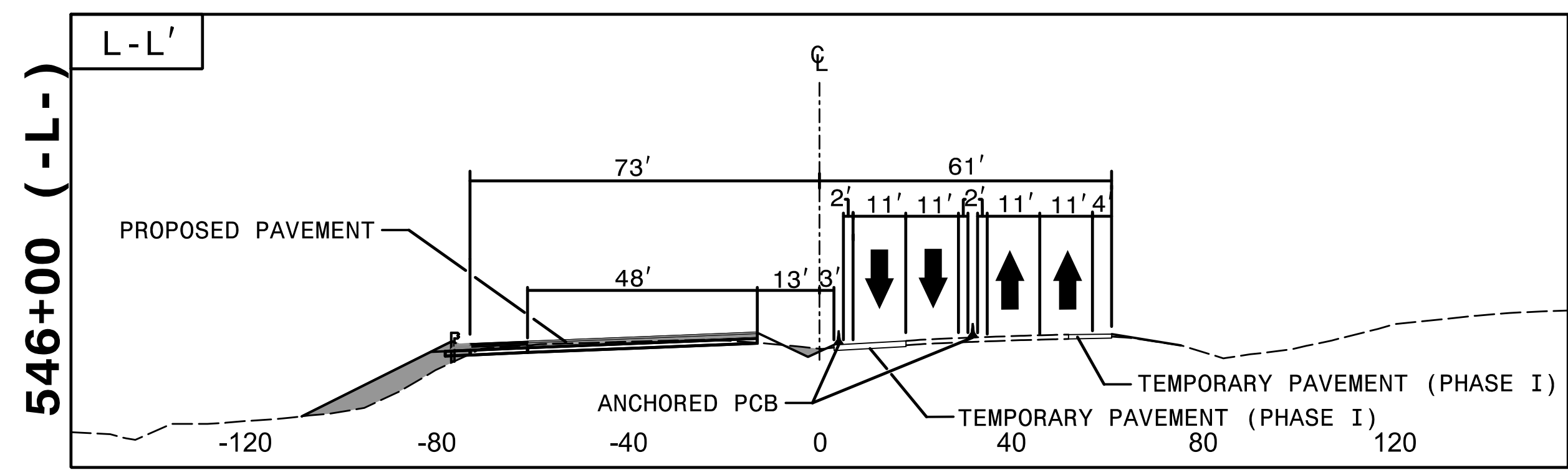
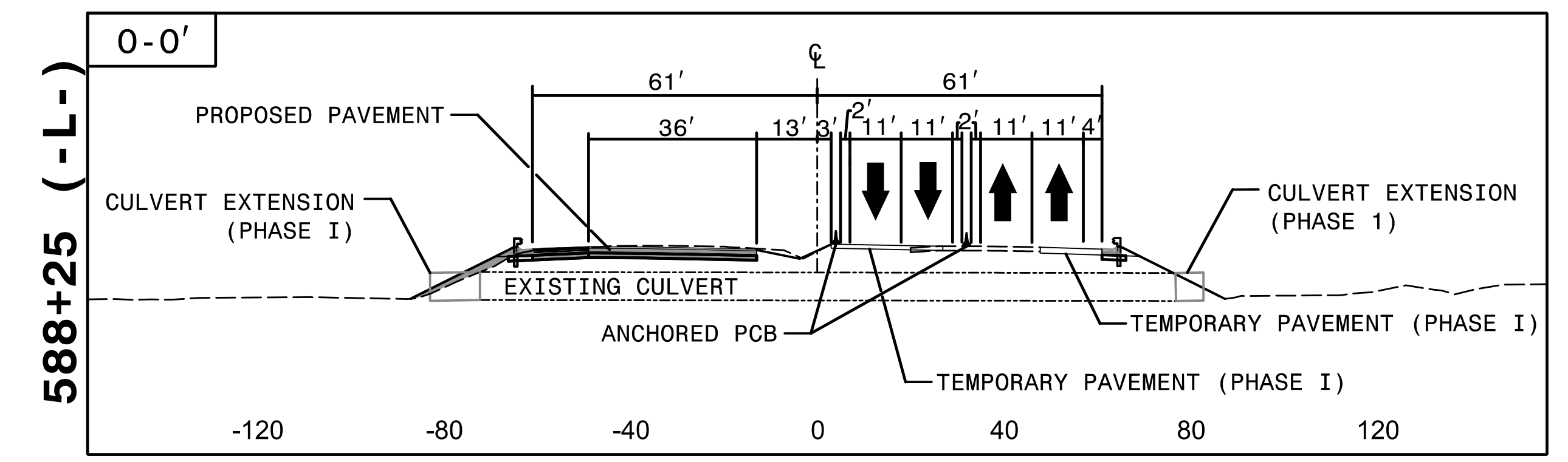
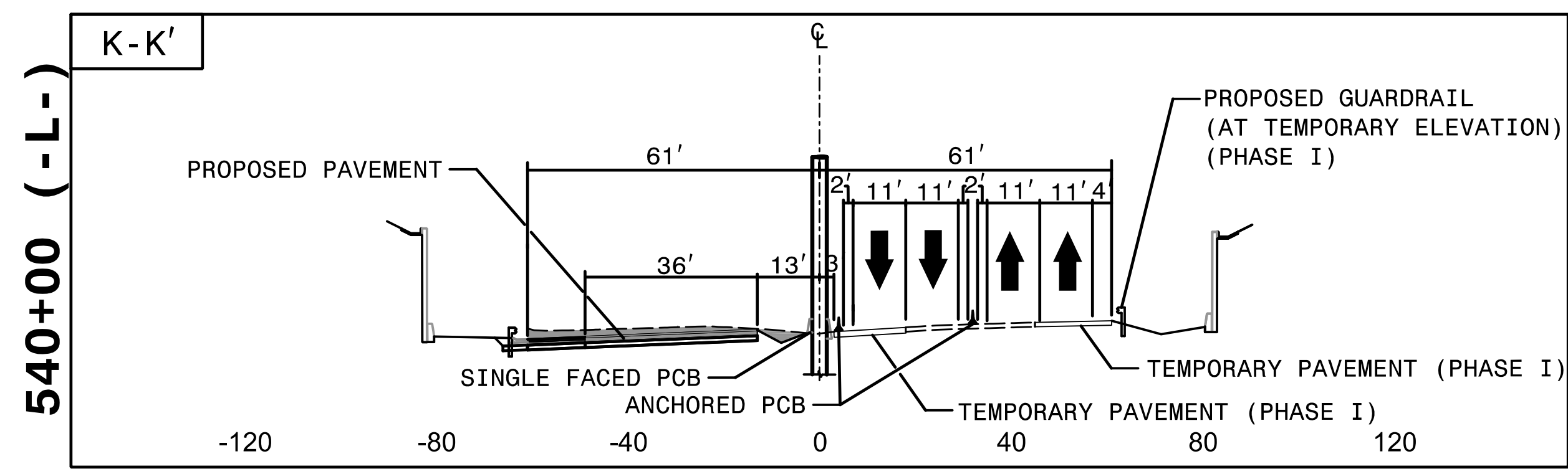
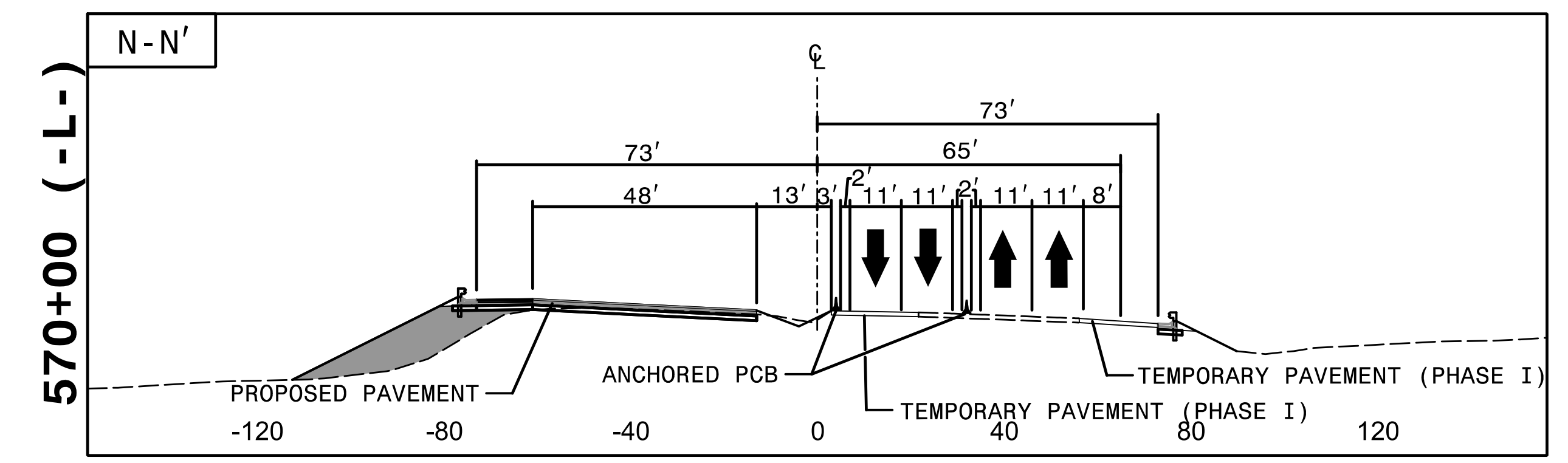
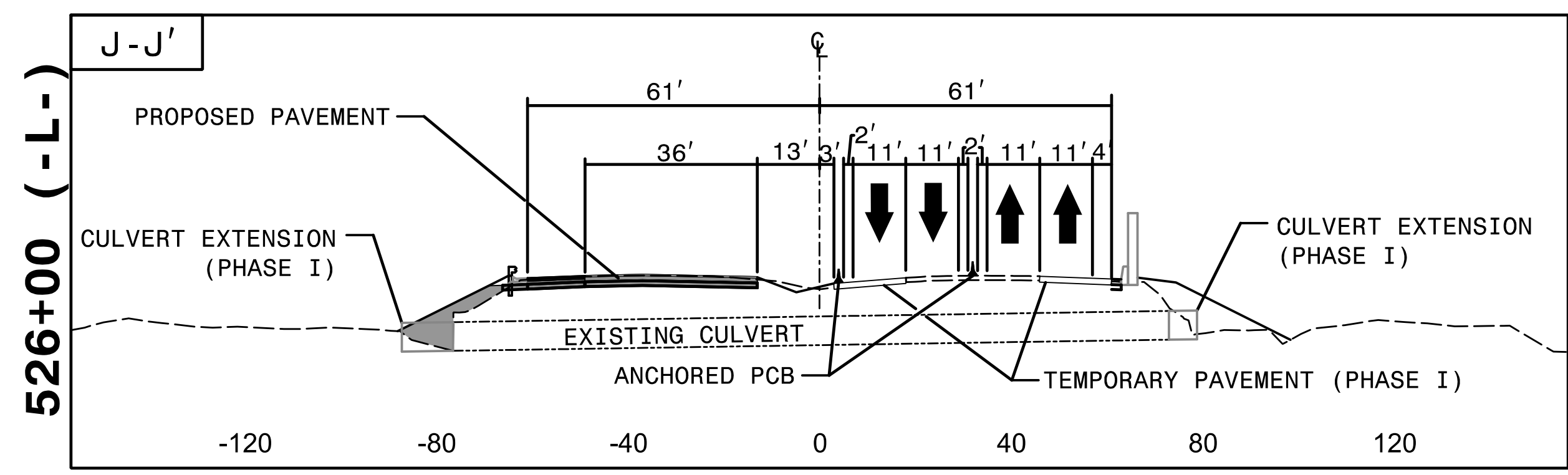
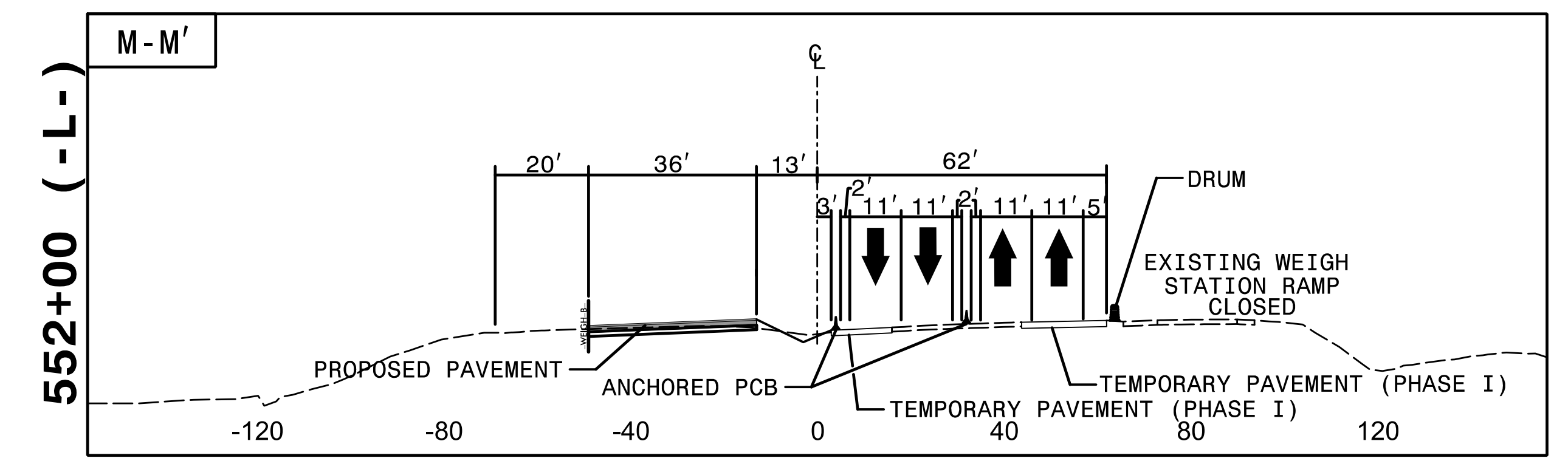
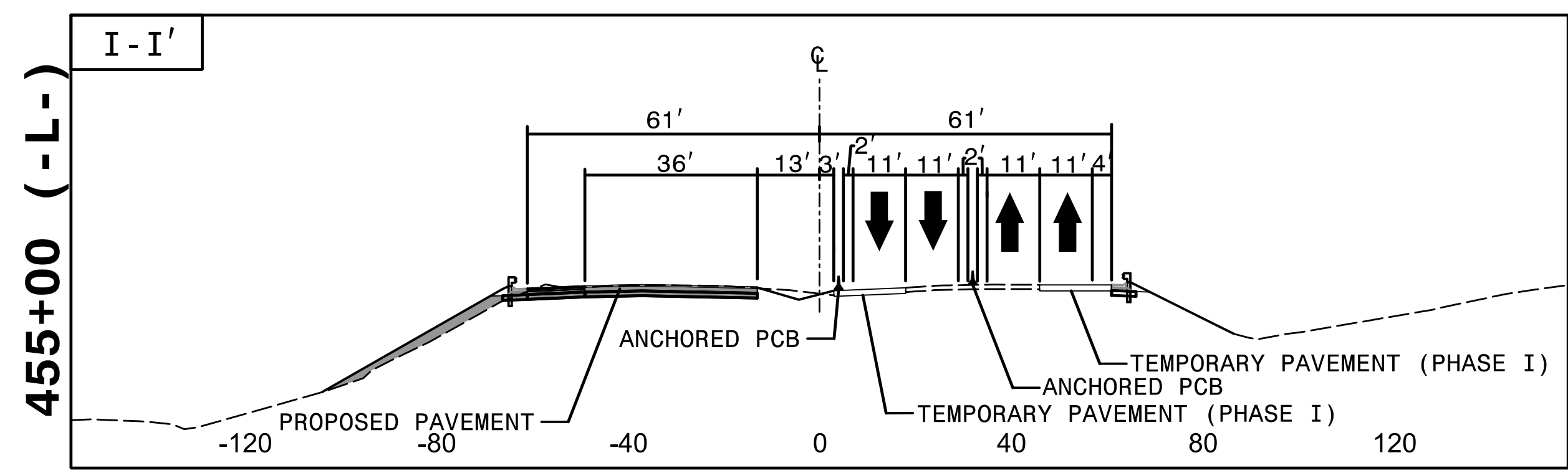

12:51:54 PM  
I:\CP\4400BB\_fc.p2 CUTS.dgn  
9/3/2019

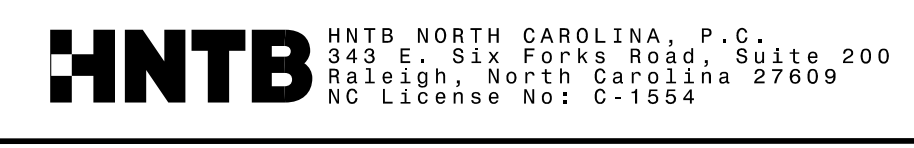

HNTB NORTH CAROLINA, P.C.  
343 E. Six Forks Road, Suite 200  
Raleigh, North Carolina 27609  
NC License No: C-1554

APPROVED: *Rhonda B. Early*  
F34CAFACBBF48A  
DATE: 9/3/2019

**DOCUMENT NOT CONSIDERED FINAL  
UNLESS ALL SIGNATURES COMPLETED**

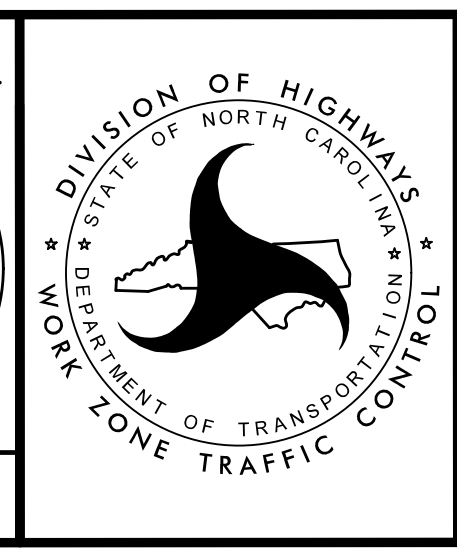

TRANSPORTATION  
MANAGEMENT PLAN  
  
PHASE II  
CUT SECTIONS

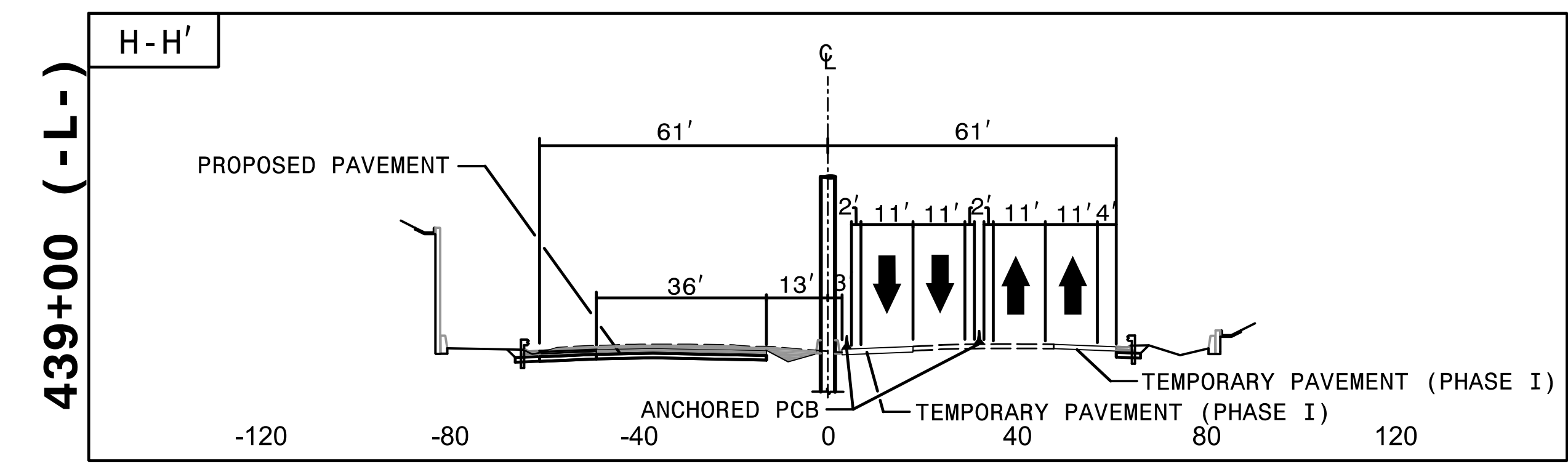
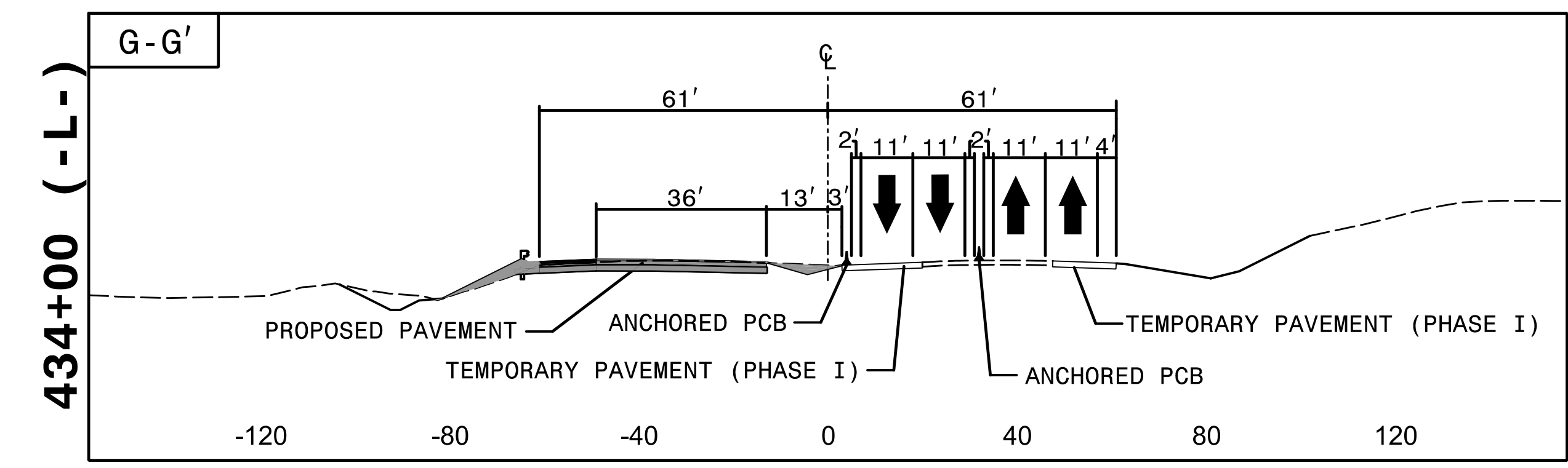
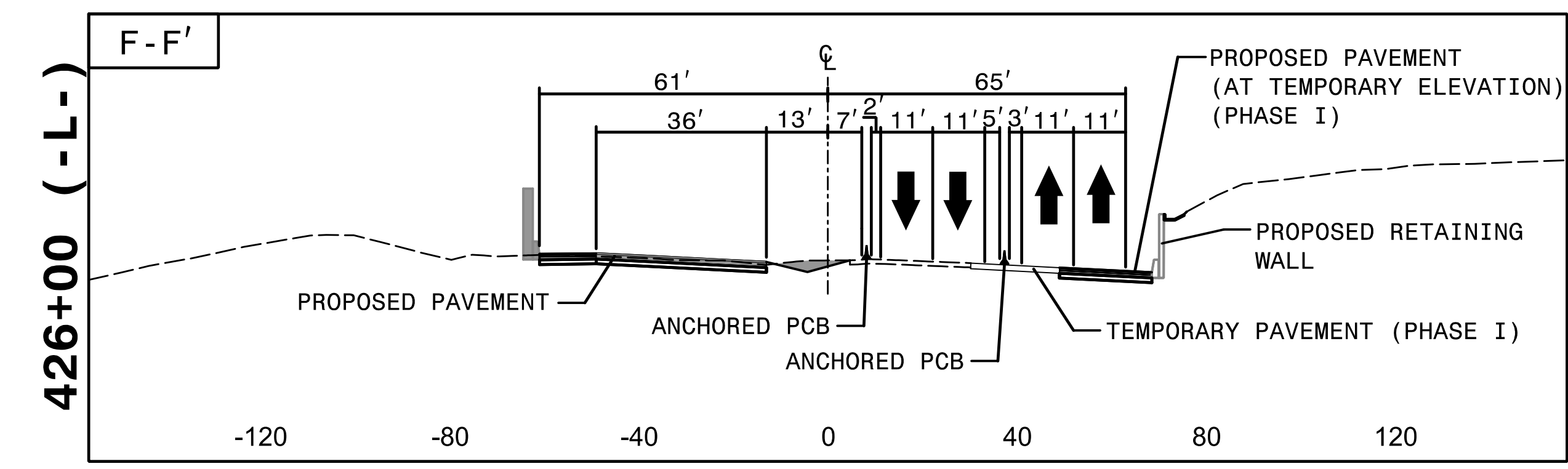
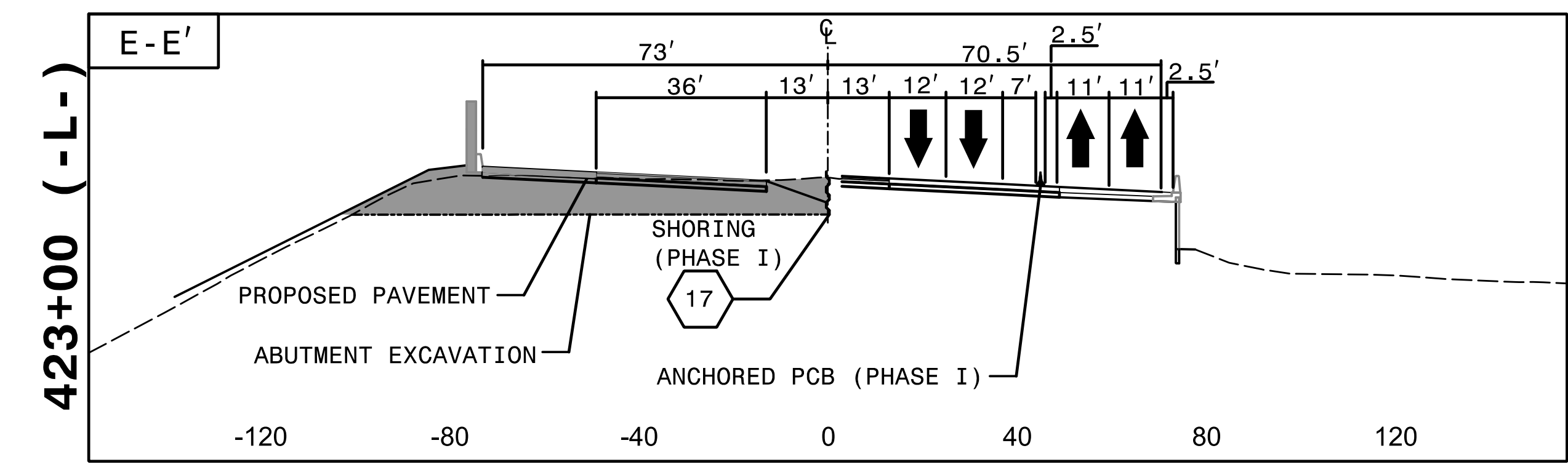
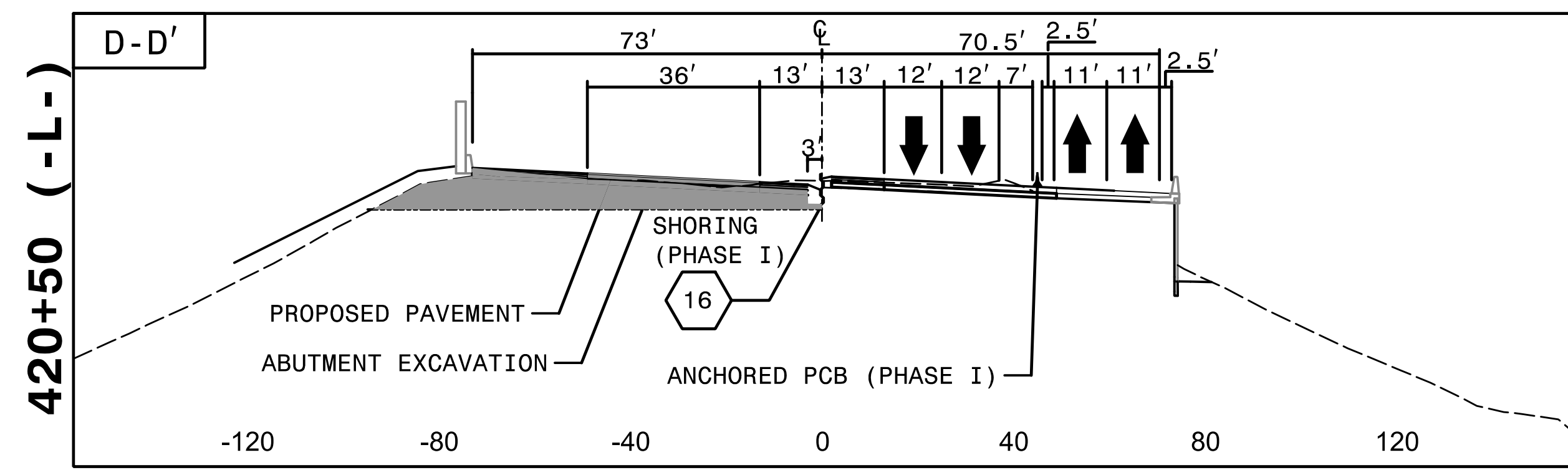
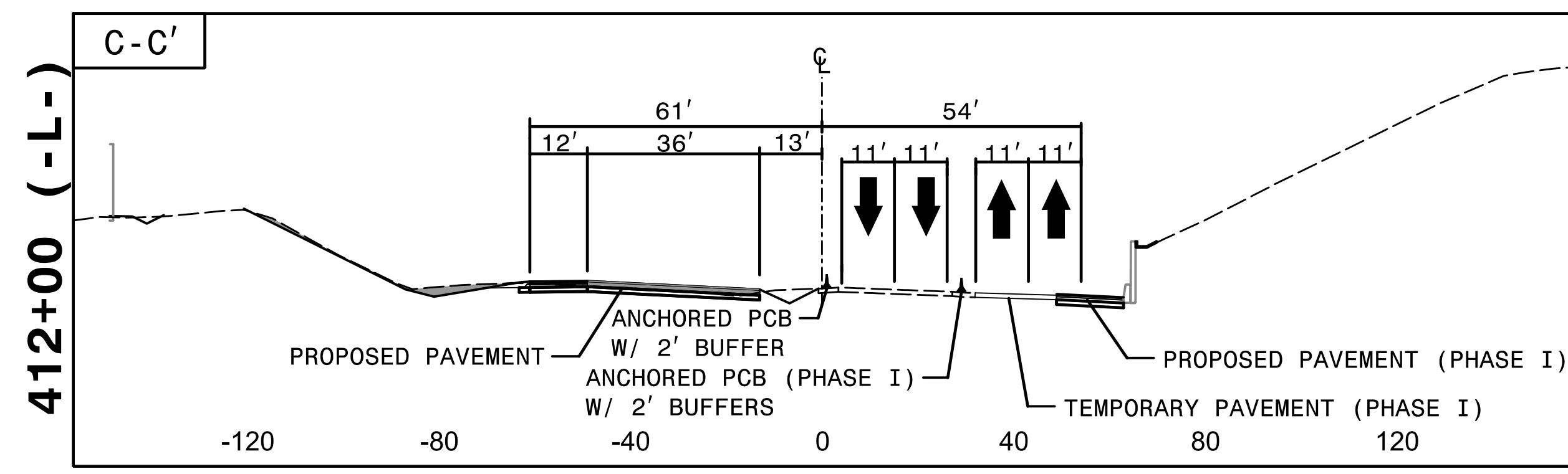
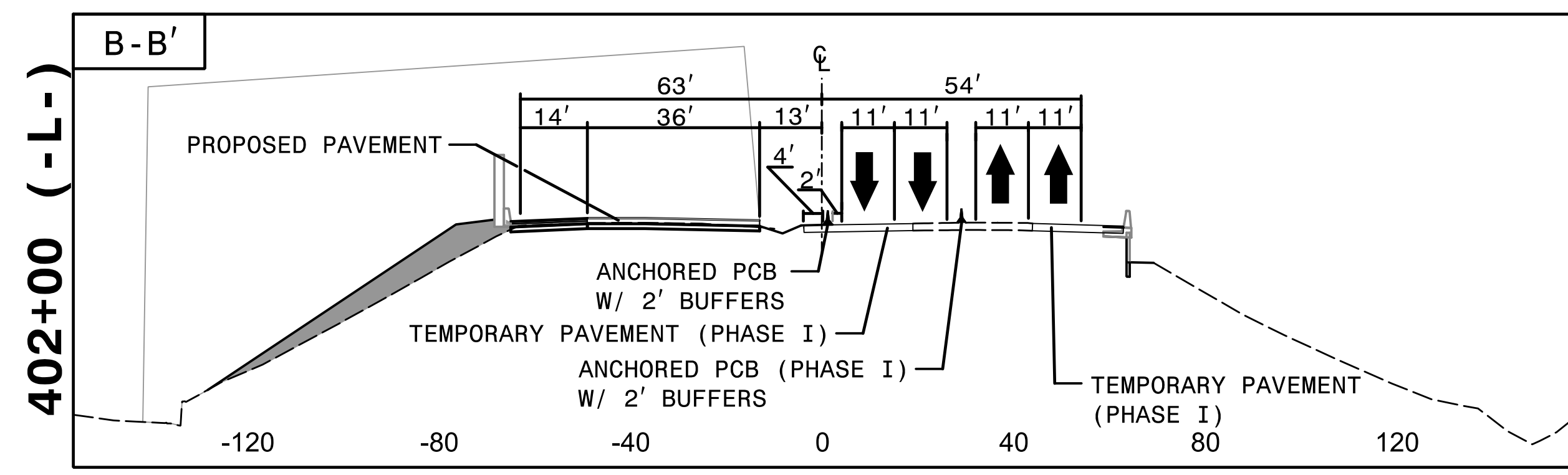
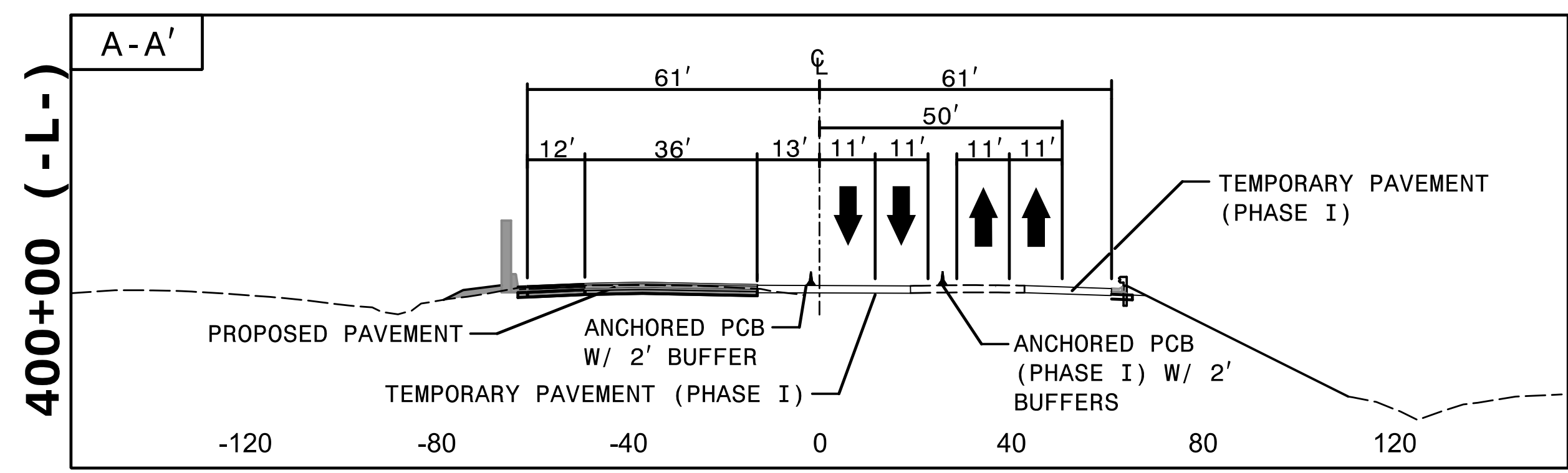

1:45:06 PM  
I:\TCN\4400BB\_fc.p2 CUTS.dgn  
9/3/2019

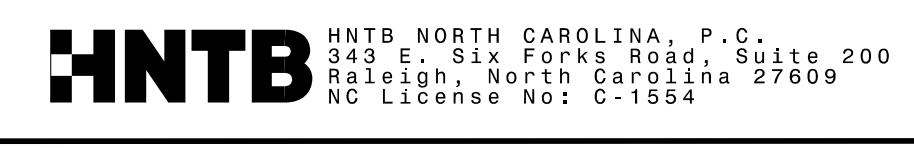

HNTB NORTH CAROLINA, P.C.  
343 E. Six Forks Road, Suite 200  
Raleigh, North Carolina 27609  
NC License No: C-1554

APPROVED: *Rhonda B. Early*  
F34CAFACBFB4A  
DATE: 9/3/2019

**NORTH CAROLINA**  
PROFESSIONAL  
SEAL  
023521  
RHONDA B. EARLY  
ENGINEER

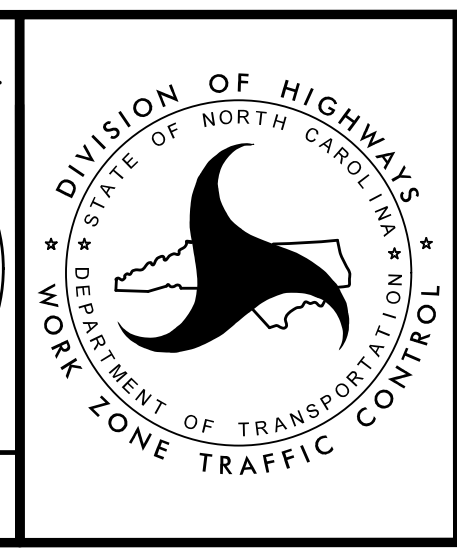

TRANSPORTATION  
MANAGEMENT PLAN  
  
PHASE II  
CUT SECTIONS

DOCUMENT NOT CONSIDERED FINAL  
UNLESS ALL SIGNATURES COMPLETED

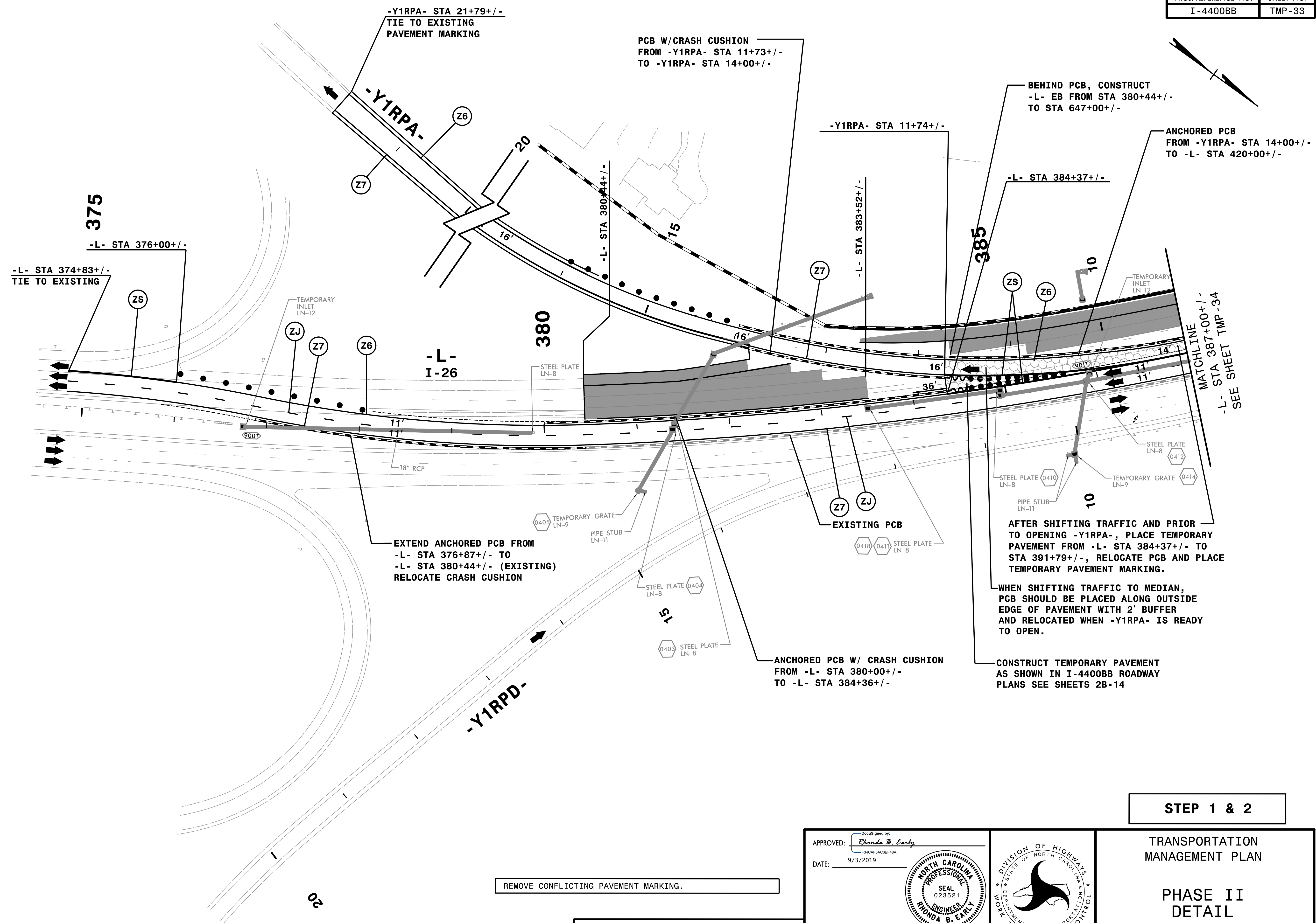

12:52:05 PM  
I:\CP\I-4400BB-t.c.p2d\dgn  
9/3/2019

REMOVE CONFLICTING PAVEMENT MARKING.

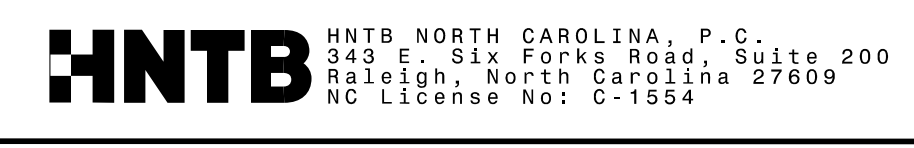

APPROVED: *Rhonda B. Early*  
 DATE: 9/3/2019

DocuSigned by:  
 F34CAF5AC8BF48A...

**NORTH CAROLINA**  
 PROFESSIONAL  
 SEAL  
 023521  
 ENGINEER  
 RHONDA B. EARLY

**DOCUMENT NOT CONSIDERED FINAL  
 UNLESS ALL SIGNATURES COMPLETED**

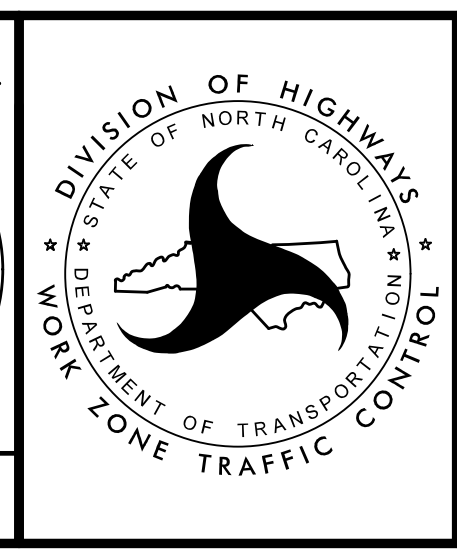

**STEP 1 & 2**

TRANSPORTATION  
 MANAGEMENT PLAN

PHASE II  
 DETAIL

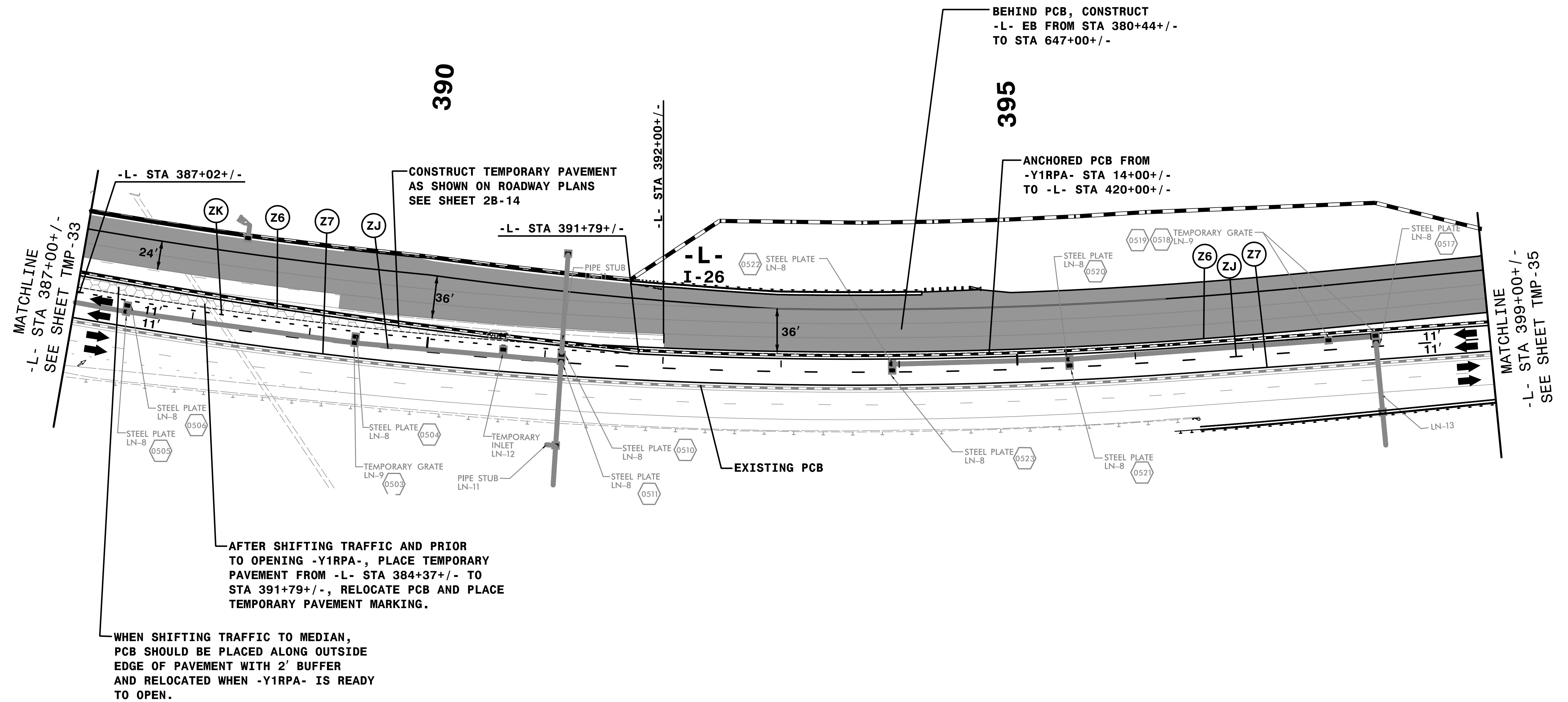

REMOVE CONFLICTING PAVEMENT MARKING.

**STEP 1**

TRANSPORTATION  
MANAGEMENT PLAN

PHASE II  
DETAIL

APPROVED: *Rhonda B. Early*  
 DATE: 9/3/2019

DocuSigned by:  
F34C4F5AC8BF48A...

**PROFESSIONAL ENGINEER**  
 NORTH CAROLINA  
 SEAL  
 023521  
 RHONDA B. EARLY

**DOCUMENT NOT CONSIDERED FINAL  
UNLESS ALL SIGNATURES COMPLETED**

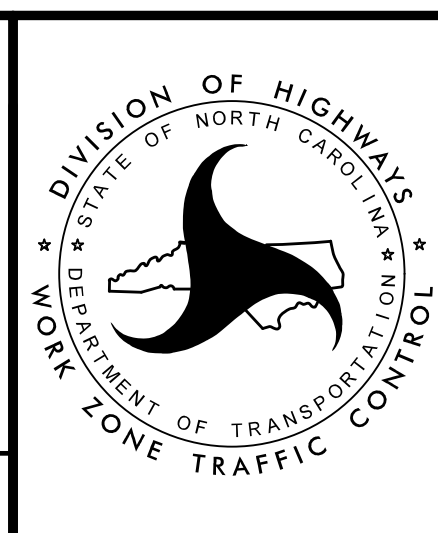

**HNTB**  
 HNTB NORTH CAROLINA, P.C.  
 343 E. Six Forks Road, Suite 200  
 Raleigh, North Carolina 27609  
 NC License No: C-1554

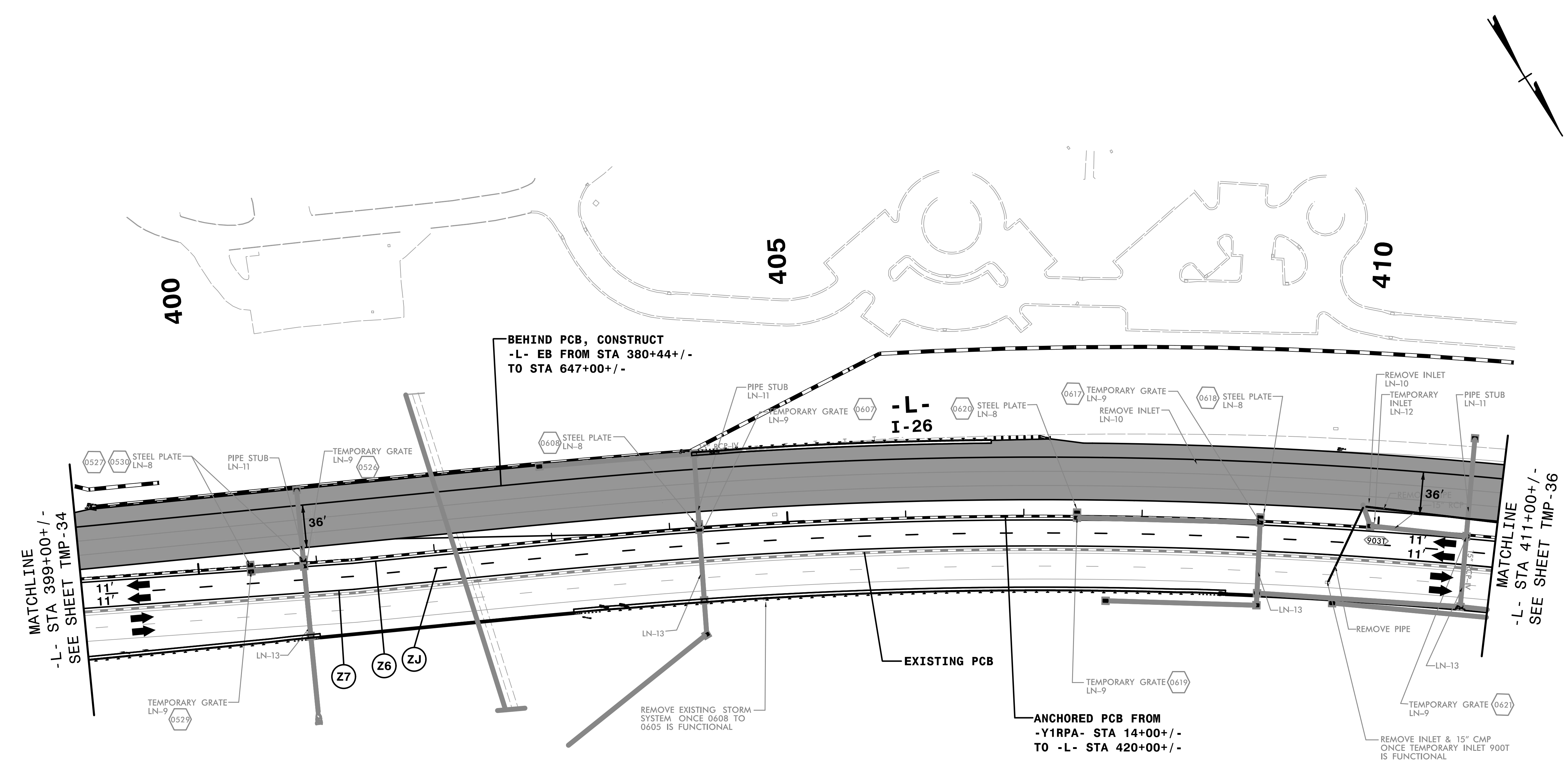

MATCHLINE  
-L- STA 399+00+/-  
SEE SHEET TMP-34

MATCHLINE  
-L- STA 411+00+/-  
SEE SHEET TMP-36

REFER TO SHEET TMP-32 FOR CUT SECTIONS.  
REMOVE CONFLICTING PAVEMENT MARKING.

**STEP 1**

12:52:17 PM  
I:\CP\I-4400BB.t.c.P2D3.dgn  
9/3/2019

**HNTB**  
HNTB NORTH CAROLINA, P.C.  
343 E. Six Forks Road, Suite 200  
Raleigh, North Carolina 27609  
NC License No: C-1554

APPROVED: *Rhonda B. Early*  
DATE: 9/3/2019  
NORTH CAROLINA PROFESSIONAL ENGINEERS  
SEAL  
023521  
RHONDA B. EARLY

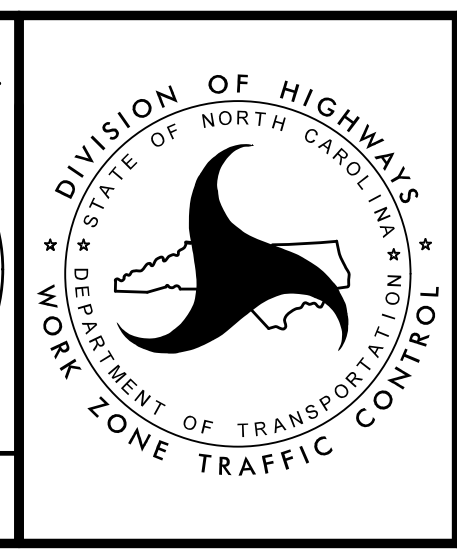

TRANSPORTATION  
MANAGEMENT PLAN  
  
PHASE II  
DETAIL

DOCUMENT NOT CONSIDERED FINAL  
UNLESS ALL SIGNATURES COMPLETED

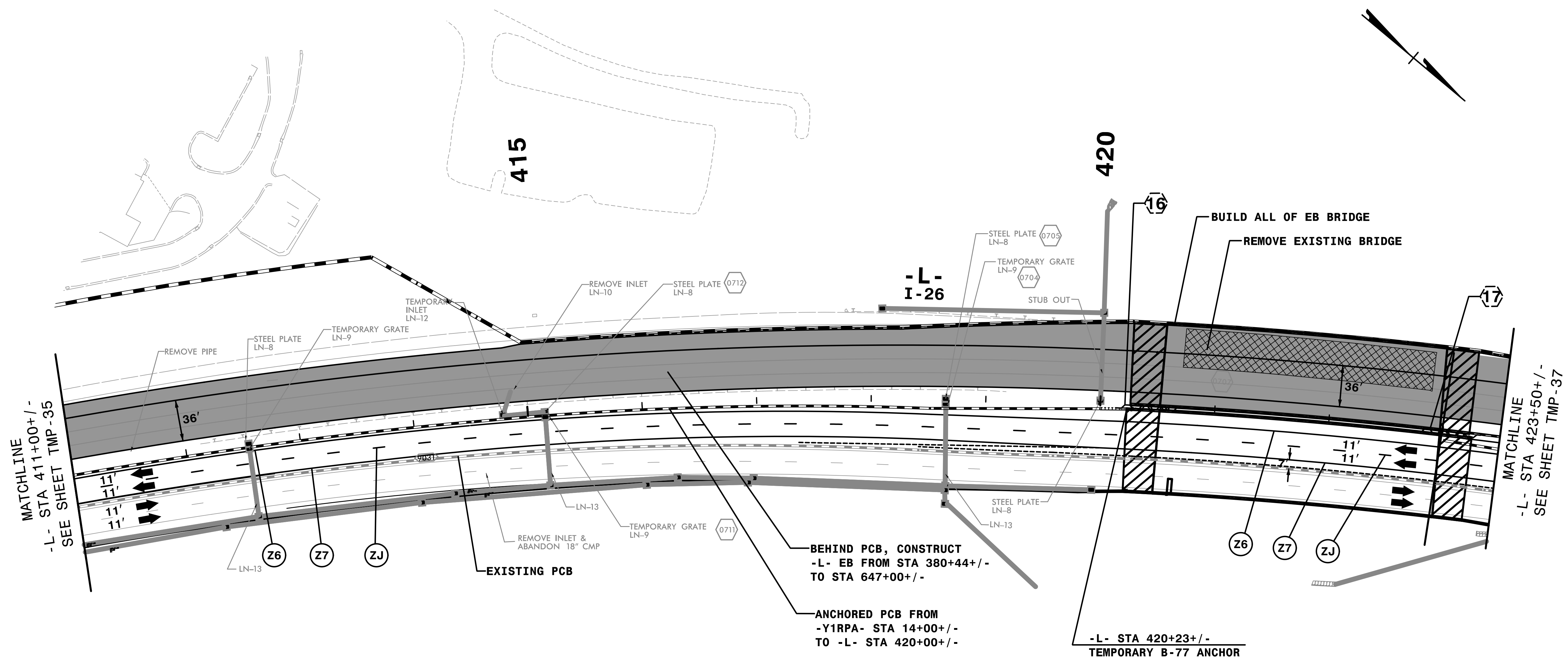

MATCHLINE  
-L- STA 411+00+/-  
SEE SHEET TMP-35

MATCHLINE  
-L- STA 423+50+/-  
SEE SHEET TMP-37

REFER TO SHEET TMP-32 FOR CUT SECTIONS.  
REMOVE CONFLICTING PAVEMENT MARKING.

**STEP 1**

TRANSPORTATION  
MANAGEMENT PLAN

PHASE II  
DETAIL

APPROVED: *Rhonda B. Early*  
DATE: 9/3/2019

DocuSigned by:  
F34CAF5AC8BF48A...

**PROFESSIONAL ENGINEER**  
NORTH CAROLINA  
SEAL  
023521  
RHONDA B. EARLY

**DOCUMENT NOT CONSIDERED FINAL  
UNLESS ALL SIGNATURES COMPLETED**

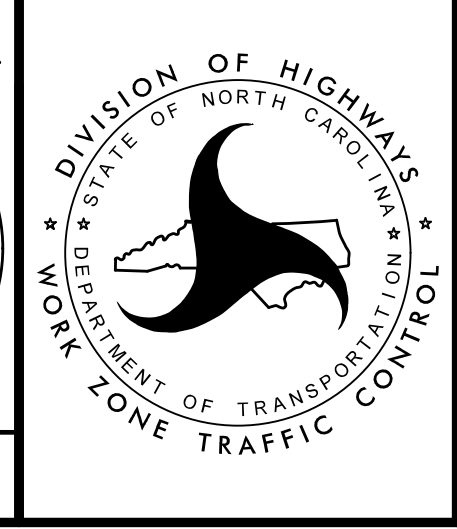

**HNTB** HNTB NORTH CAROLINA, P.C.  
343 E. Six Forks Road, Suite 200  
Raleigh, North Carolina 27609  
NC License No: C-1554

12:52:24 PM  
I:\CP\I-4400BB.t.c.P2D4.dgn  
9/3/2019

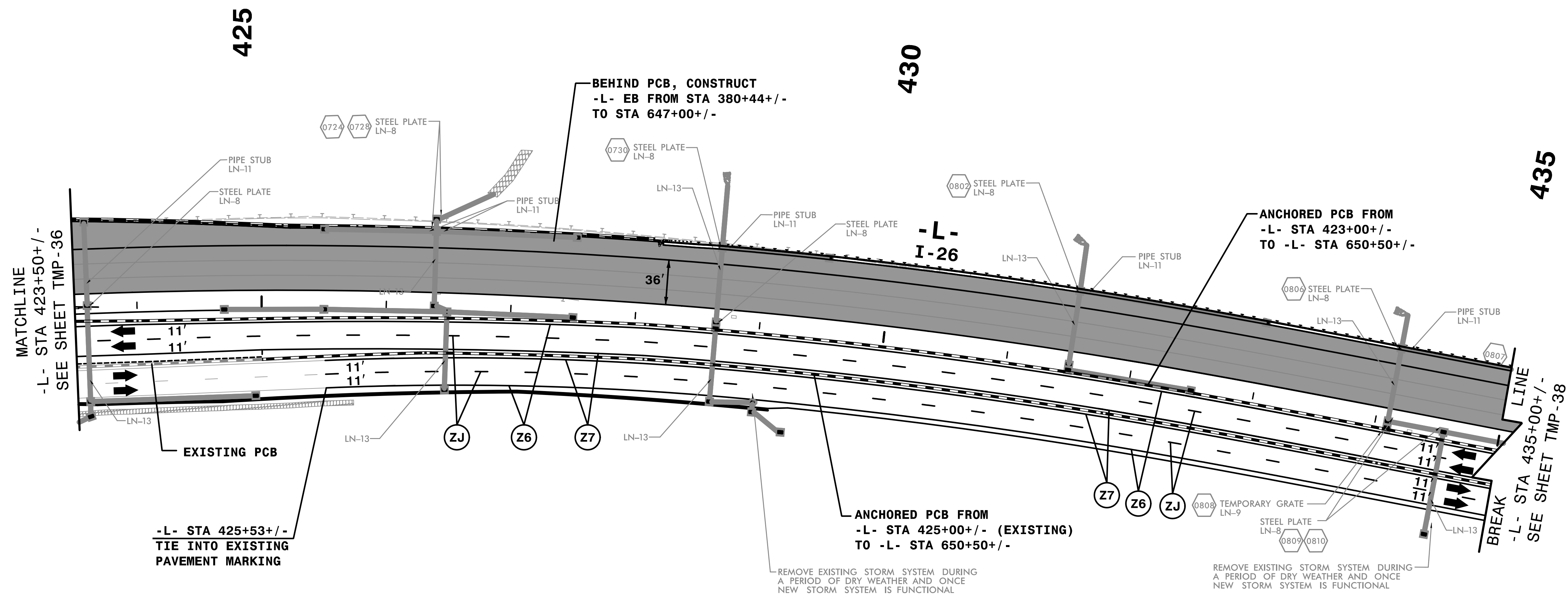
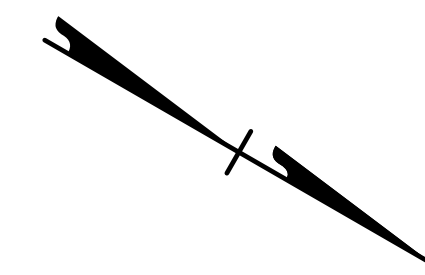

REFER TO SHEET TMP-32 FOR CUT SECTIONS.

REMOVE CONFLICTING PAVEMENT MARKING.

**STEP 1**

I2:52:29 PM  
\\FPC\1-4400BB-1.cad\2019.dgn  
9/3/2019

**HNTB** HNTB NORTH CAROLINA, P.C.  
343 E. SIX FORKS ROAD, SUITE 200  
RALEIGH, NORTH CAROLINA 27609  
NC License No: C-1554

APPROVED: *Rhonda B. Early*  
DATE: 9/3/2019

**NORTH CAROLINA**  
PROFESSIONAL  
ENGINEERS  
RHONDA B. EARLY  
SEAL 023521

**DOCUMENT NOT CONSIDERED FINAL  
UNLESS ALL SIGNATURES COMPLETED**

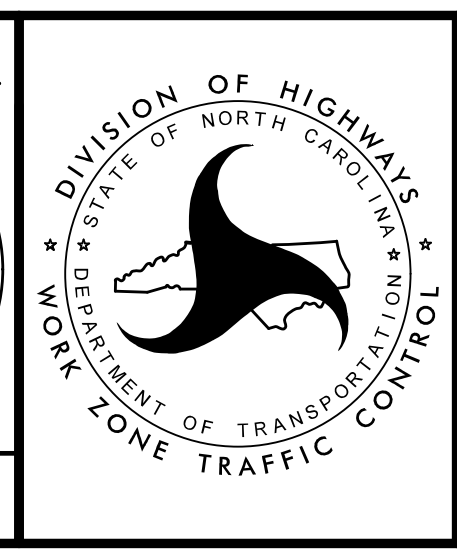

TRANSPORTATION  
MANAGEMENT PLAN

**PHASE II  
DETAIL**



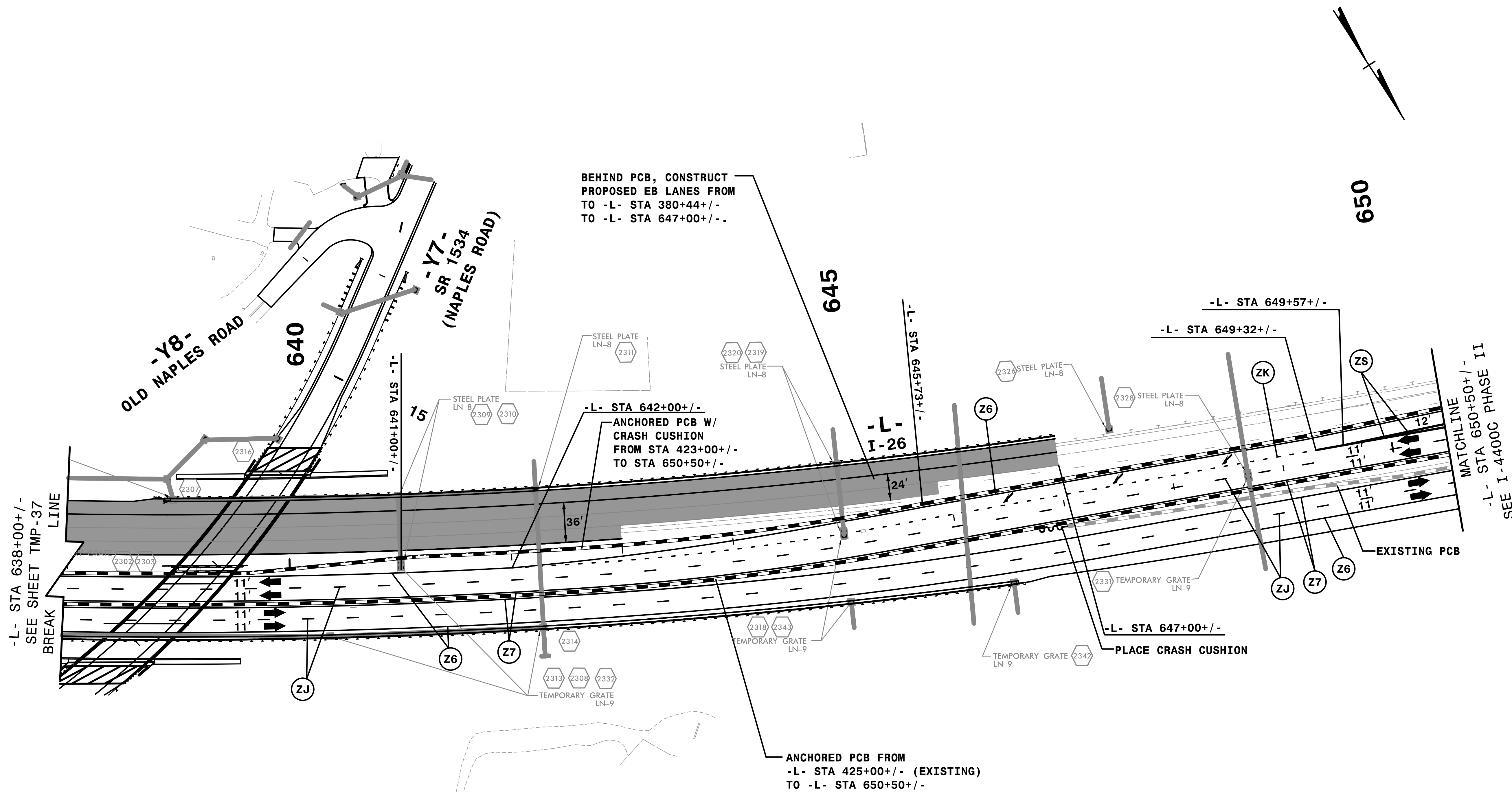

REFER TO SHEET TMP-32A FOR CUT SECTIONS.

REMOVE CONFLICTING PAVEMENT MARKING.

**STEP 1**

TRANSPORTATION MANAGEMENT PLAN

PHASE II DETAIL

APPROVED: *Rhonda B. Early*

DATE: 9/3/2019

DocuSigned by: Rhonda B. Early  
F34CAFAC8BF48A...

**PROFESSIONAL ENGINEER**  
NORTH CAROLINA  
SEAL 023521  
RHONDA B. EARLY

**DOCUMENT NOT CONSIDERED FINAL UNLESS ALL SIGNATURES COMPLETED**



**HNTB**

HNTB NORTH CAROLINA, P.C.  
343 E. Six Forks Road, Suite 200  
Raleigh, North Carolina 27609  
NC License No: C-1554

9/3/2019  
I:\CPN\I-4400BB.t.c.P2D23.dgn  
\$\$\$\$\$DATE\$\$\$\$\$

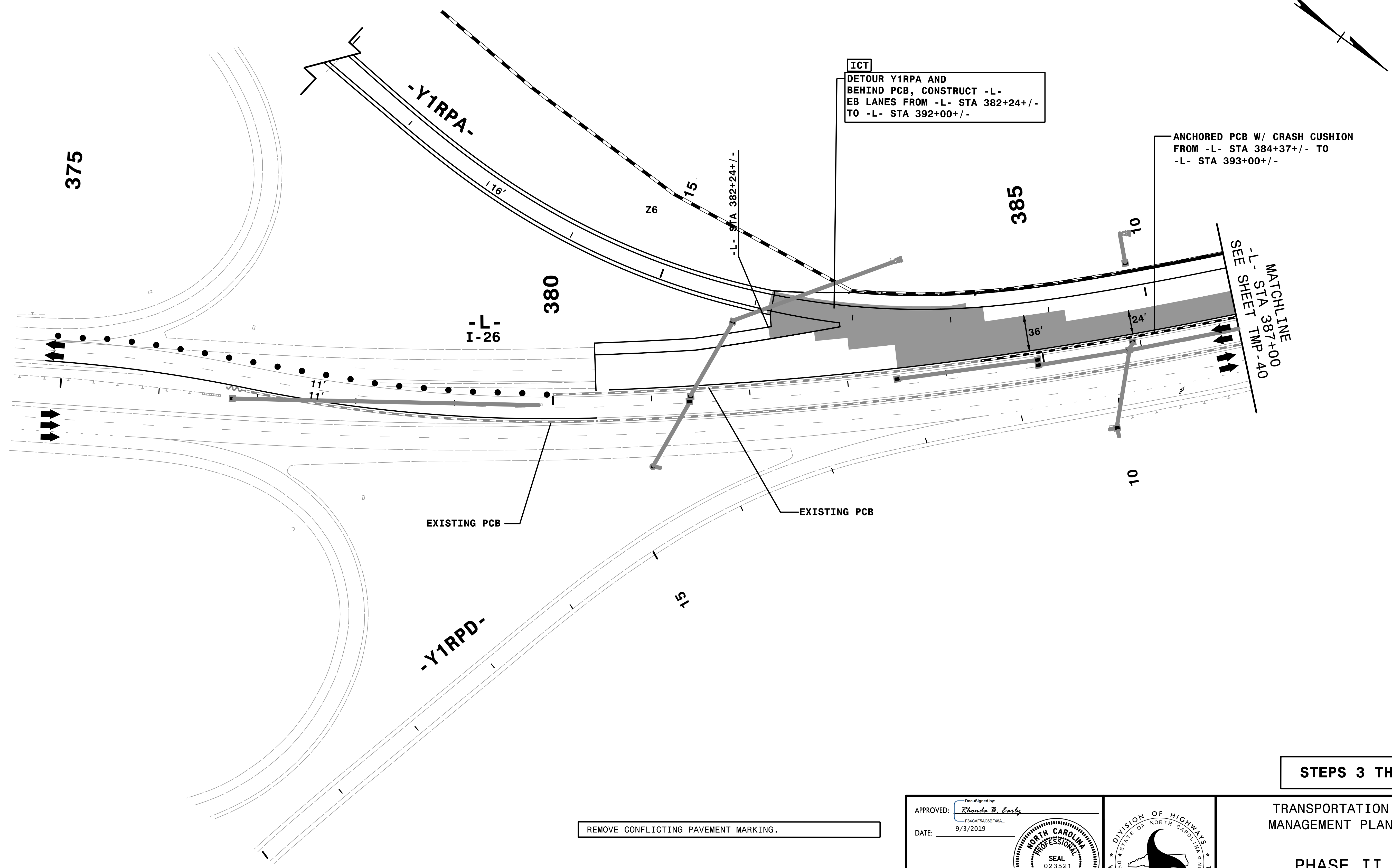

STEPS 3 THRU 5

REMOVE CONFLICTING PAVEMENT MARKING.

APPROVED: *Rhonda B. Early*  
F34CASFAC68F48A  
 DATE: 9/3/2019

**NORTH CAROLINA PROFESSIONAL ENGINEER**  
 SEAL  
 023521  
 RHONDA B. EARLY

**DOCUMENT NOT CONSIDERED FINAL UNLESS ALL SIGNATURES COMPLETED**



TRANSPORTATION MANAGEMENT PLAN

PHASE II DETAIL

**HNTB** HNTB NORTH CAROLINA, P.C.  
 343 E. SIX FORKS ROAD, SUITE 200  
 RALEIGH, NORTH CAROLINA 27609  
 NC LICENSE NO: C-1554

4:32:19 PM  
 I:\CP\N\I-4400BB.t.c.P2a.dwg  
 9/3/2019

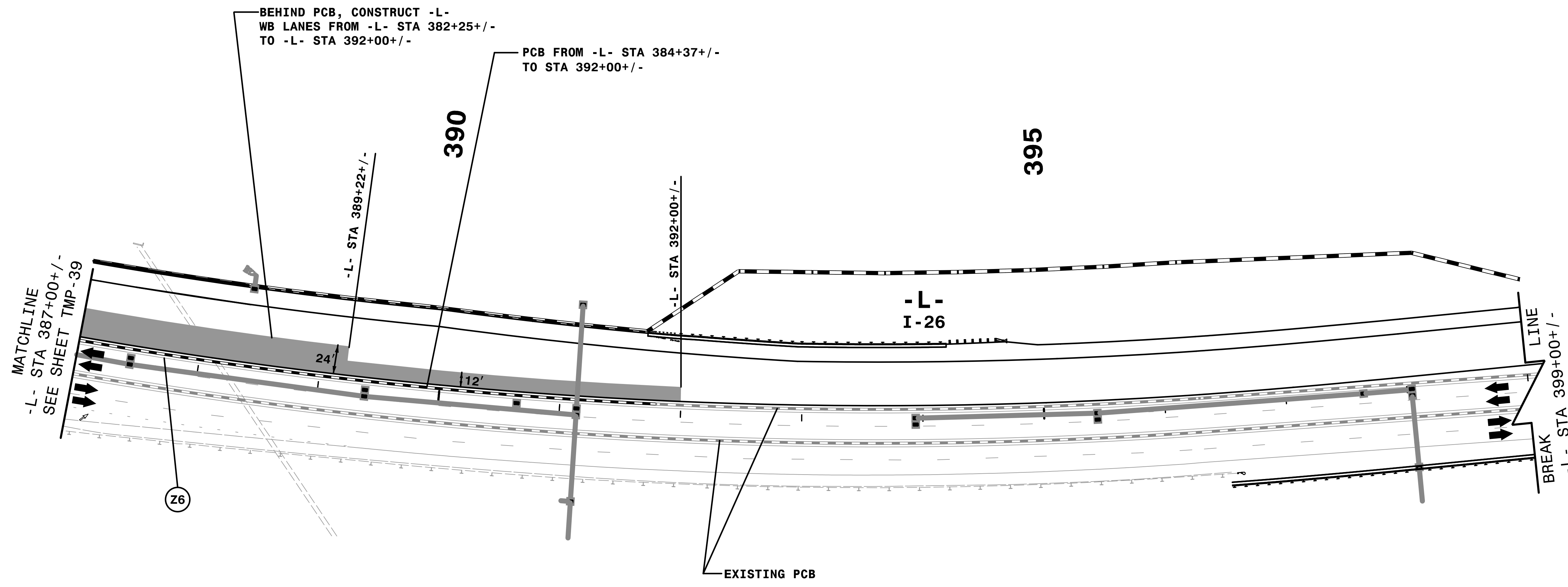

**STEPS 3 THRU 5**

TRANSPORTATION MANAGEMENT PLAN

PHASE II DETAIL

APPROVED: *Rhonda B. Early*  
F34CAF5ACBF4BA  
 DATE: 9/3/2019

**DOCUMENT NOT CONSIDERED FINAL UNLESS ALL SIGNATURES COMPLETED**

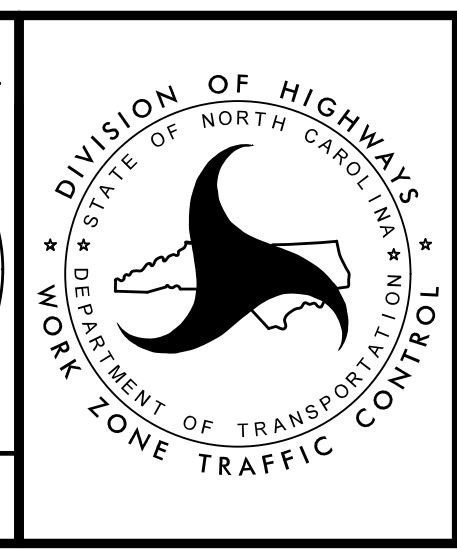

**HNTB** HNTB NORTH CAROLINA, P.C.  
 349 E. Six Forks Road, Suite 200  
 Raleigh, North Carolina 27609  
 NC License No: C-1554

4:32:26 PM  
 \\TCN\1-4400BB-t.c.p2ad2.dgn  
 9/3/2019

**SHEET OMITTED**

4:32:52 PM  
\\TCF\I-4400BB-1.c. P2ad3.dgn  
9/3/2019

**HNTB** HNTB NORTH CAROLINA, P.C.  
343 E. SIX FORKS ROAD, SUITE 200  
RALEIGH, NORTH CAROLINA 27609  
NC License No: C-1554

APPROVED: \_\_\_\_\_  
DATE: \_\_\_\_\_

**DOCUMENT NOT CONSIDERED FINAL  
UNLESS ALL SIGNATURES COMPLETED**



TRANSPORTATION  
MANAGEMENT PLAN

**PHASE II  
DETAIL**

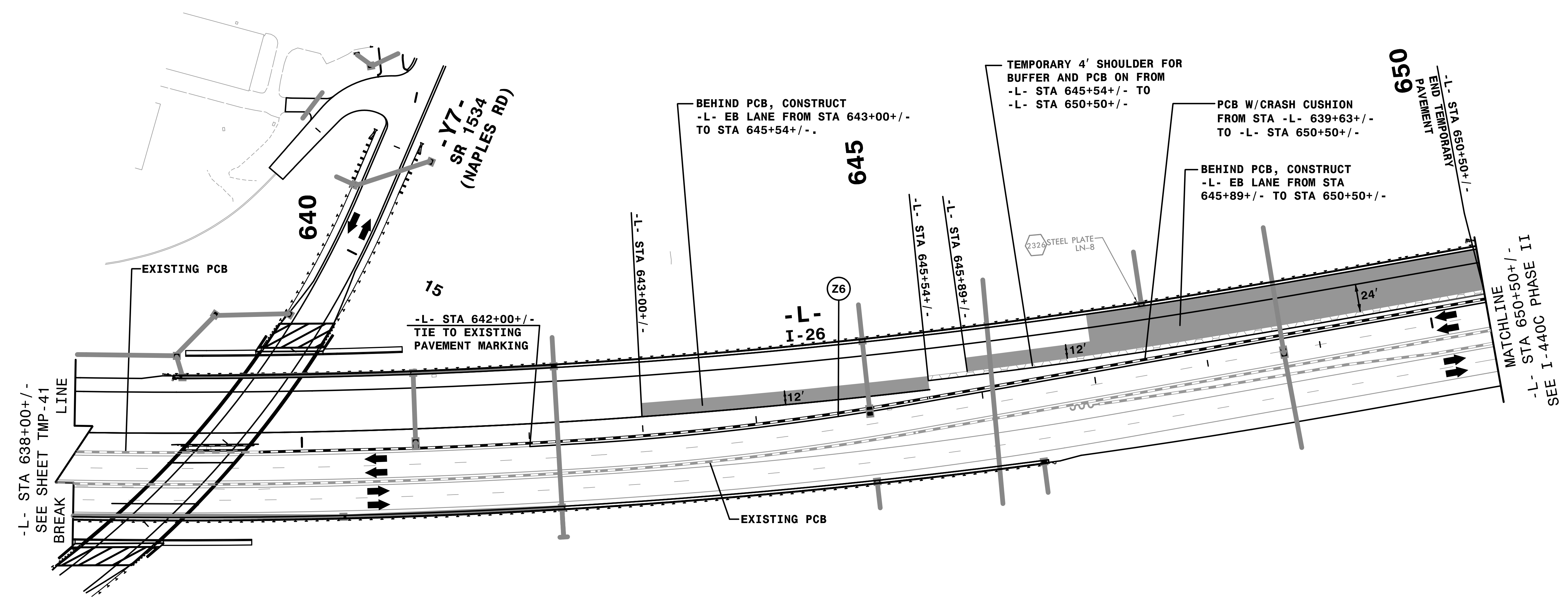
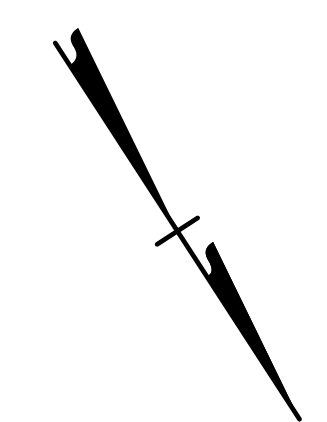

12:53:36 PM  
 I:\CPN\I-4400BB.tcd\p2ad23.dgn  
 9/3/2019

**STEPS 3 THRU 6**

TRANSPORTATION  
 MANAGEMENT PLAN

PHASE II  
 DETAIL

**HNTB** HNTB NORTH CAROLINA, P.C.  
 349 E. Six Forks Road, Suite 200  
 Raleigh, North Carolina 27609  
 NC License No: C-1554

APPROVED: *Rhonda B. Early*  
 DATE: 9/3/2019

DocuSigned by:  
 F34CAFAC8BF48A...

**SEAL**  
 NORTH CAROLINA  
 PROFESSIONAL  
 ENGINEERS  
 RHONDA B. EARLY  
 023521

**DOCUMENT NOT CONSIDERED FINAL  
 UNLESS ALL SIGNATURES COMPLETED**

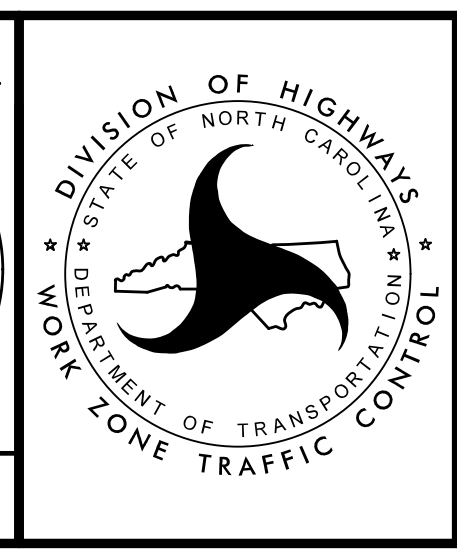

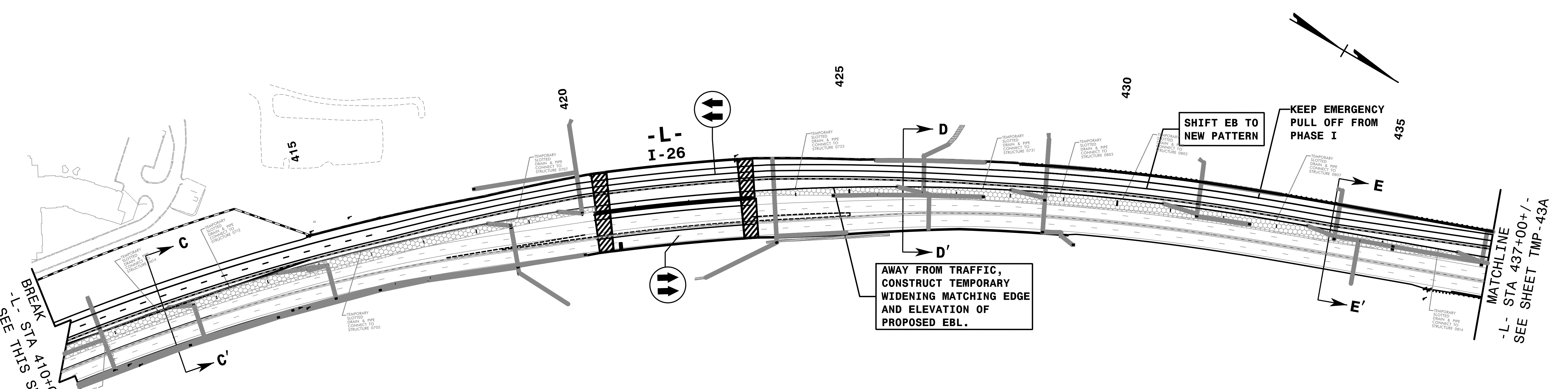
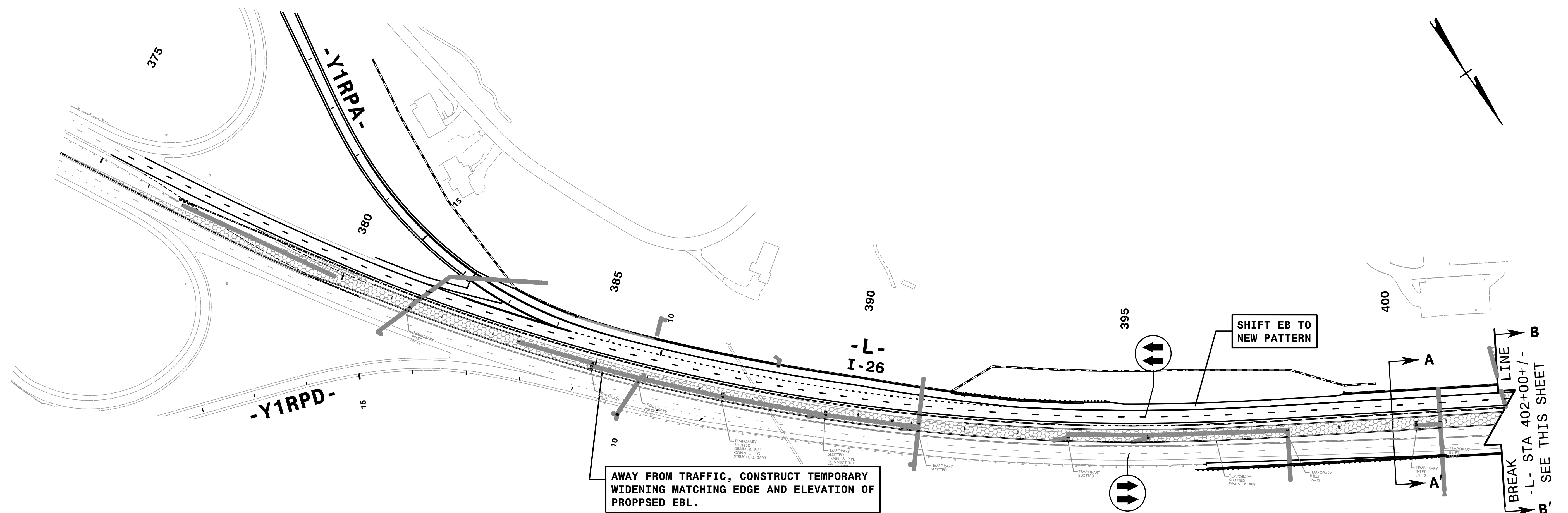

4:48:13 PM  
T:\at\fileControl\TCP\OV\p3-1.dgn  
9/3/2019

**HNTB** HNTB NORTH CAROLINA, P.C.  
343 E. SIX FORKS ROAD, SUITE 200  
RALEIGH, NORTH CAROLINA 27609  
NC LICENSE NO: C-1554

APPROVED: *Rhonda B. Early*  
DATE: 9/3/2019

**PROFESSIONAL SEAL**  
023521  
RHONDA B. EARLY  
ENGINEER

**DOCUMENT NOT CONSIDERED FINAL  
UNLESS ALL SIGNATURES COMPLETED**



TRANSPORTATION  
MANAGEMENT PLAN

PHASE III  
OVERVIEW

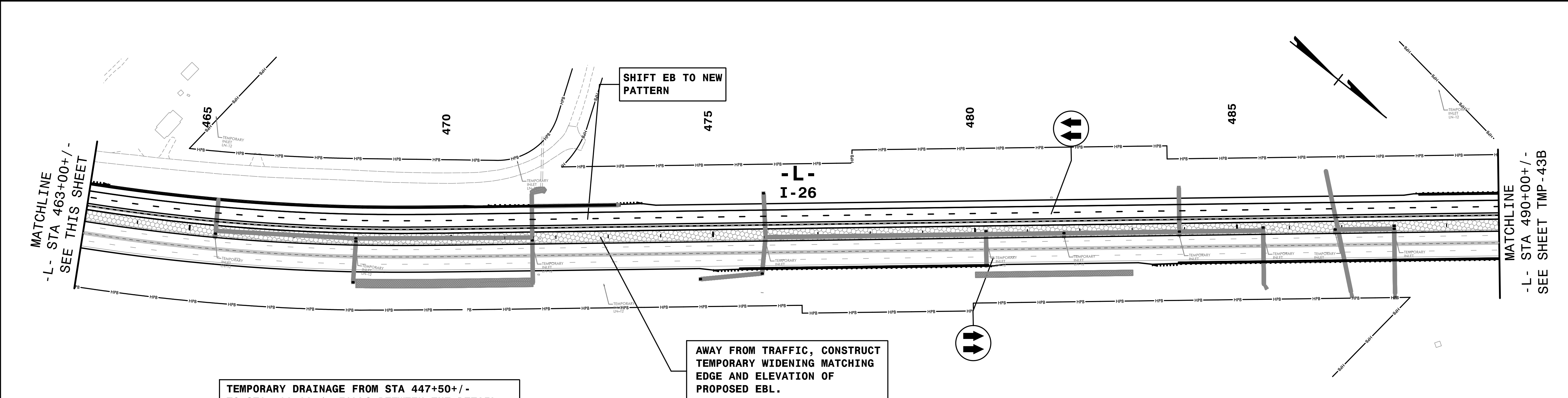
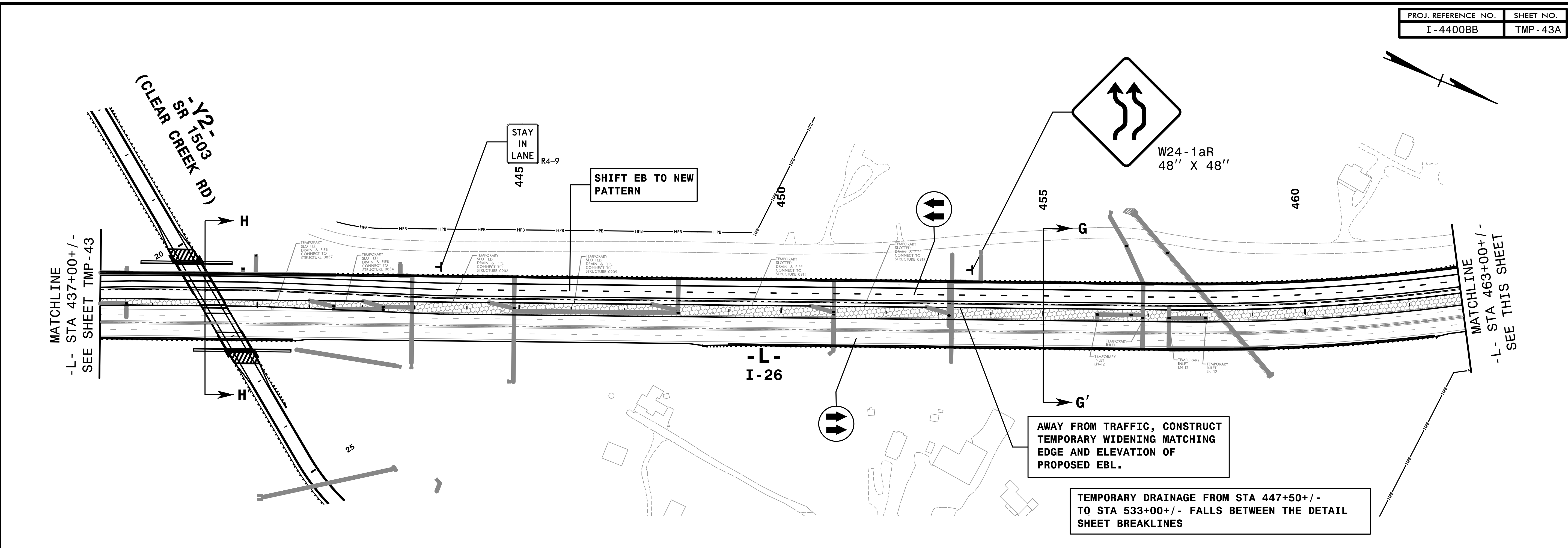

12:57:07 PM  
N:\TrafficControl\TCP\OV\_P3\_2.dgn  
9/3/2019

**HNTB**  
HNTB NORTH CAROLINA, P.C.  
343 E. SIX FORKS ROAD, SUITE 200  
RALEIGH, NORTH CAROLINA 27609  
NC LICENSE NO: C-1554

APPROVED: *Rhonda B. Early*  
F3MCAFSACBFA8A  
DATE: 9/3/2019

**SEAL**  
NORTH CAROLINA  
PROFESSIONAL  
ENGINEERS  
RHONDA B. EARLY  
023521

**DOCUMENT NOT CONSIDERED FINAL  
UNLESS ALL SIGNATURES COMPLETED**



TRANSPORTATION  
MANAGEMENT PLAN

PHASE III  
OVERVIEW

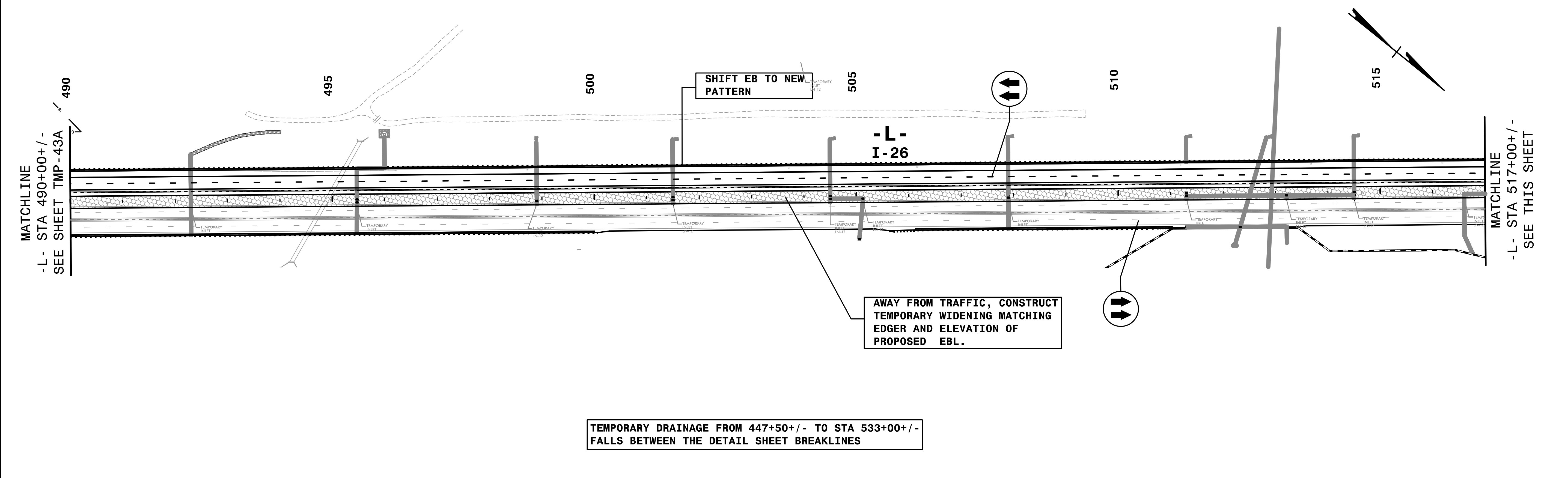

TEMPORARY DRAINAGE FROM 447+50+/- TO STA 533+00+/- FALLS BETWEEN THE DETAIL SHEET BREAKLINES

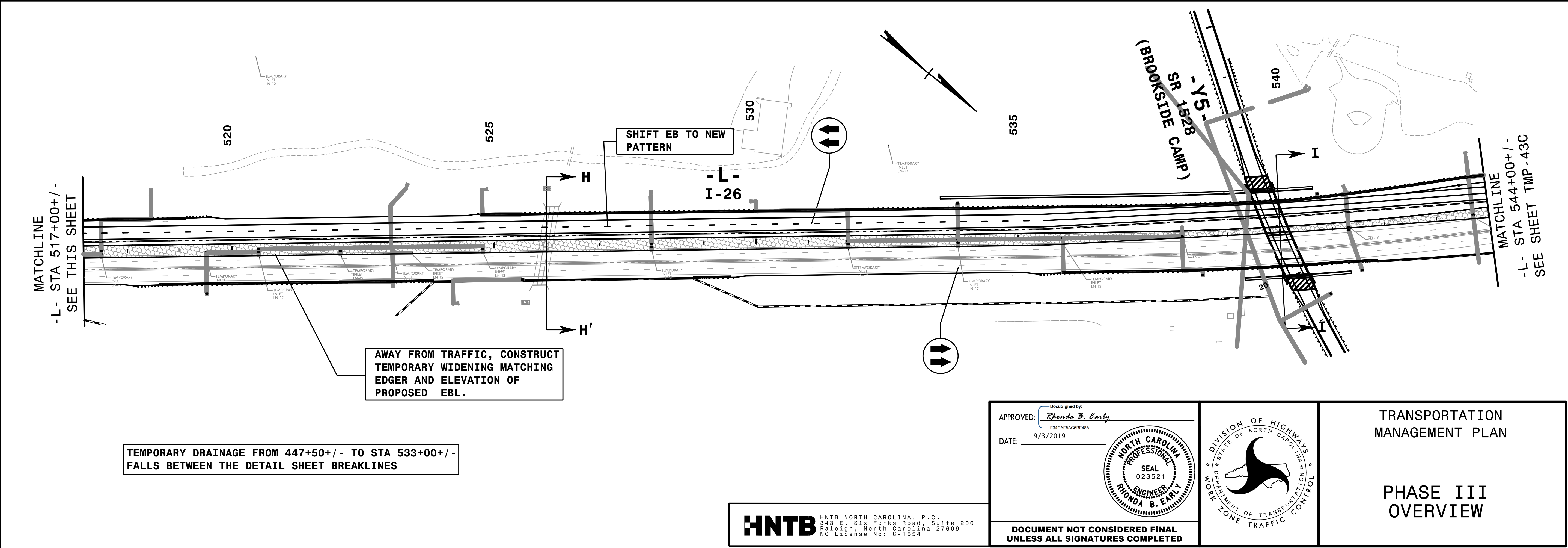

TEMPORARY DRAINAGE FROM 447+50+/- TO STA 533+00+/- FALLS BETWEEN THE DETAIL SHEET BREAKLINES

12:57:27 PM  
 \\T:\aff\Control\TCP\0V\p3\_3.dgn  
 9/3/2019

**HNTB**  
 HNTB NORTH CAROLINA, P.C.  
 343 E. Six Forks Road, Suite 200  
 Raleigh, North Carolina 27609  
 NC License No: C-1554

APPROVED: *Rhonda B. Early*  
 Rhonda B. Early  
 F3MCAFSACBF48A  
 DATE: 9/3/2019

SEAL  
 NORTH CAROLINA  
 PROFESSIONAL ENGINEER  
 RHONDA B. EARLY  
 023521

DOCUMENT NOT CONSIDERED FINAL  
 UNLESS ALL SIGNATURES COMPLETED

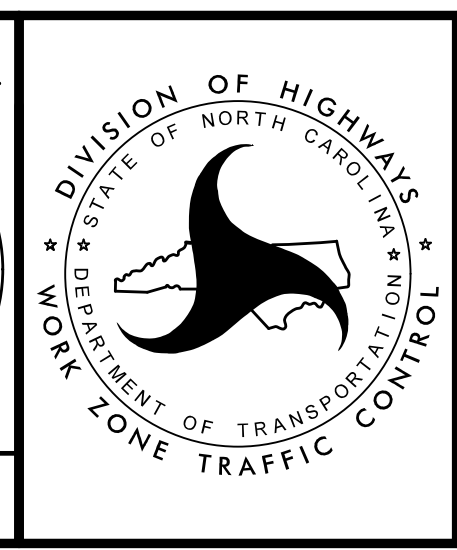

TRANSPORTATION  
 MANAGEMENT PLAN

PHASE III  
 OVERVIEW



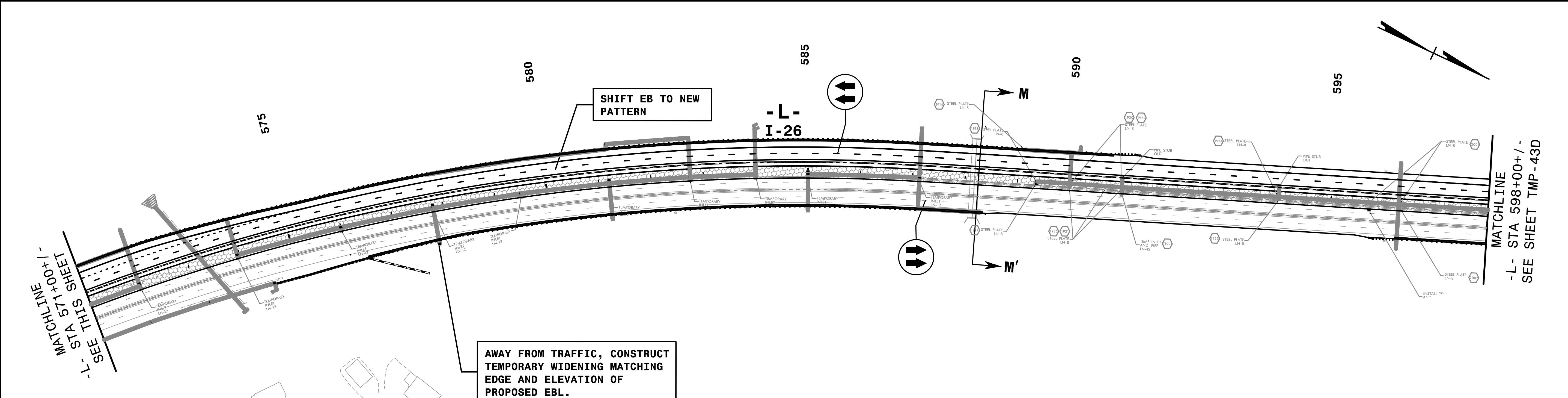
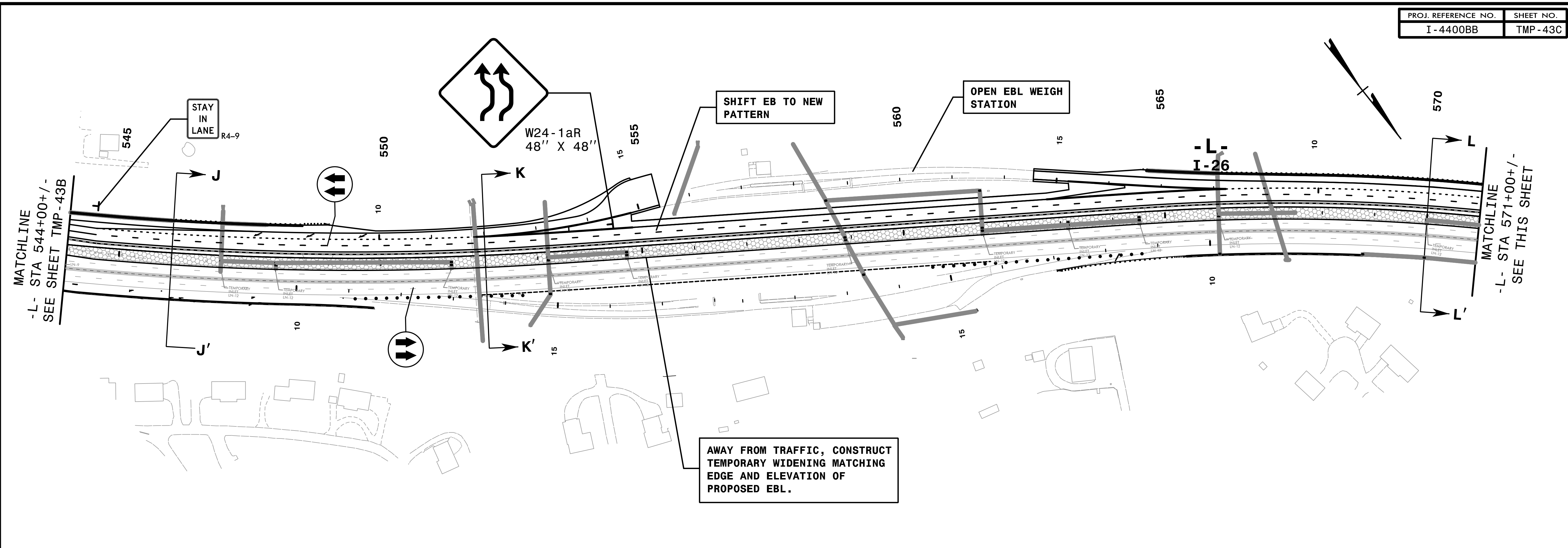

TEMPORARY DRAINAGE FROM STA 580+00+/- TO STA 627+00+/- FALLS BETWEEN THE DETAIL SHEET AND BREAKLINES

12:57:46 PM  
 \\tr\office\control\TCP\OV\_P3\_4.dgn  
 9/3/2019

**HNTB**  
 HNTB NORTH CAROLINA, P.C.  
 343 E. Six Forks Road, Suite 200  
 Raleigh, North Carolina 27609  
 NC License No: C-1554

APPROVED: *Rhonda B. Early*  
 DATE: 9/3/2019  
 NORTH CAROLINA PROFESSIONAL ENGINEER  
 SEAL 023521  
 RHONDA B. EARLY

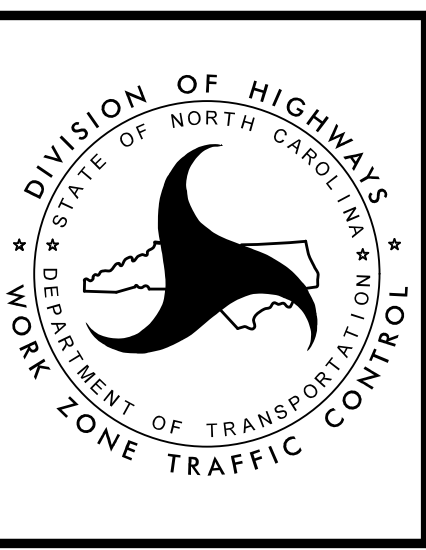

TRANSPORTATION MANAGEMENT PLAN  
 PHASE III OVERVIEW  
 DOCUMENT NOT CONSIDERED FINAL UNLESS ALL SIGNATURES COMPLETED

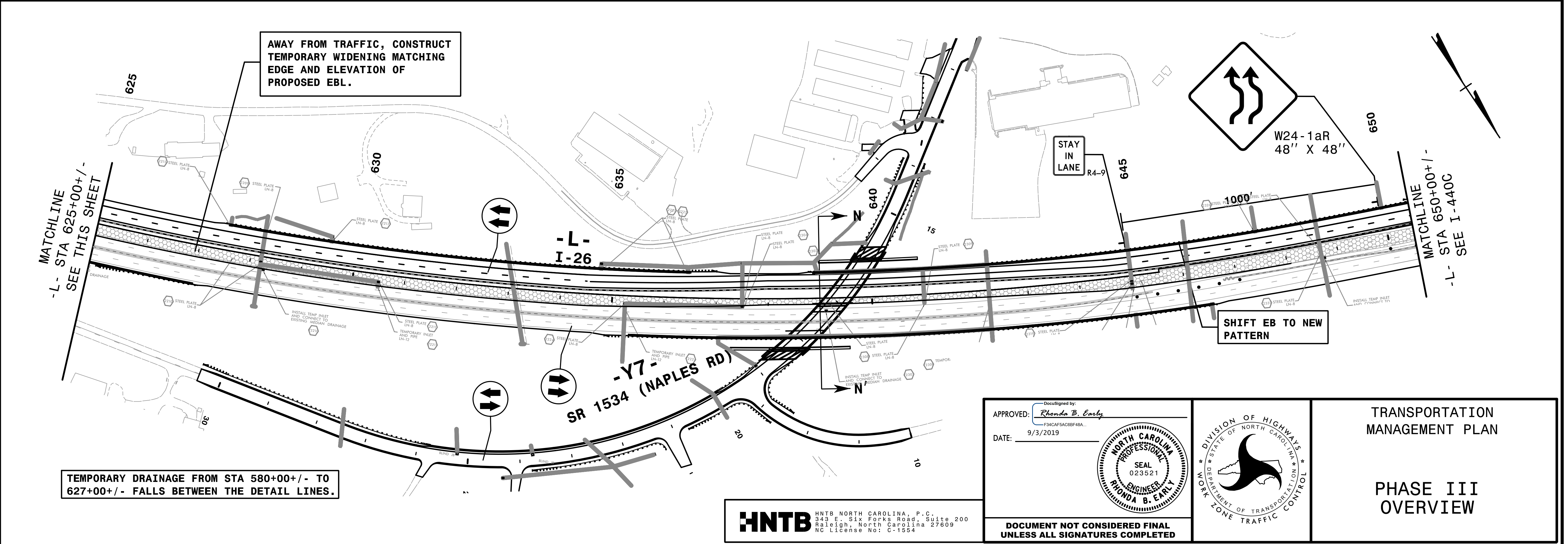
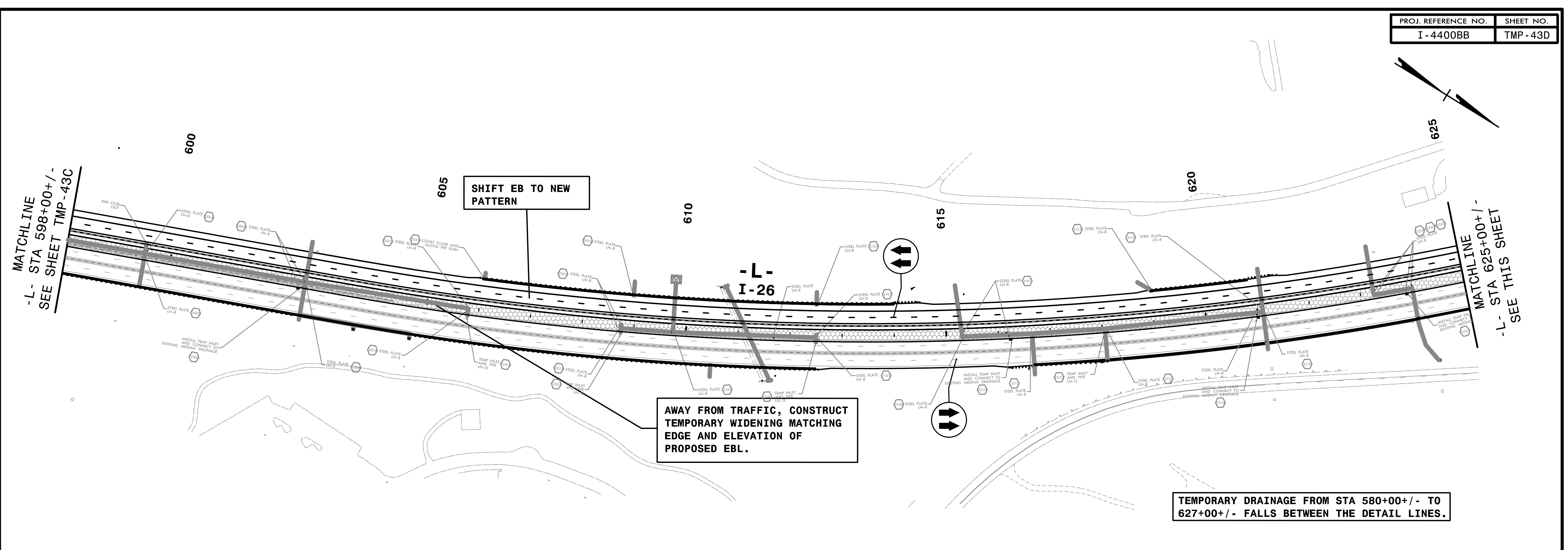

12:58:05 PM  
\\nc\at\off\control\TCP\01\_V\_P3\_5.dgn  
9/3/2019

TEMPORARY DRAINAGE FROM STA 580+00 +/- TO 627+00 +/- FALLS BETWEEN THE DETAIL LINES.

**HNTB**  
HNTB NORTH CAROLINA, P.C.  
343 E. Six Forks Road, Suite 200  
Raleigh, North Carolina 27609  
NC License No: C-1554

APPROVED: *Rhonda B. Early*  
F534CFA5ACBF48A...  
DATE: 9/3/2019

DocuSigned by:  
*Rhonda B. Early*  
F534CFA5ACBF48A...

9/3/2019

**NORTH CAROLINA PROFESSIONAL ENGINEERS & ARCHITECTS**  
SEAL  
023521  
**RHONDA B. EARLY**

**DOCUMENT NOT CONSIDERED FINAL UNLESS ALL SIGNATURES COMPLETED**

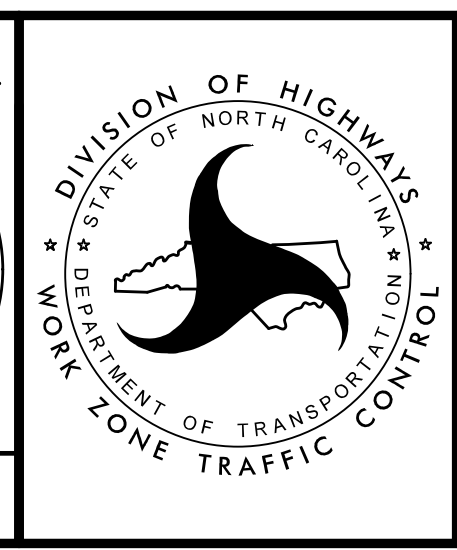

TRANSPORTATION MANAGEMENT PLAN

PHASE III OVERVIEW

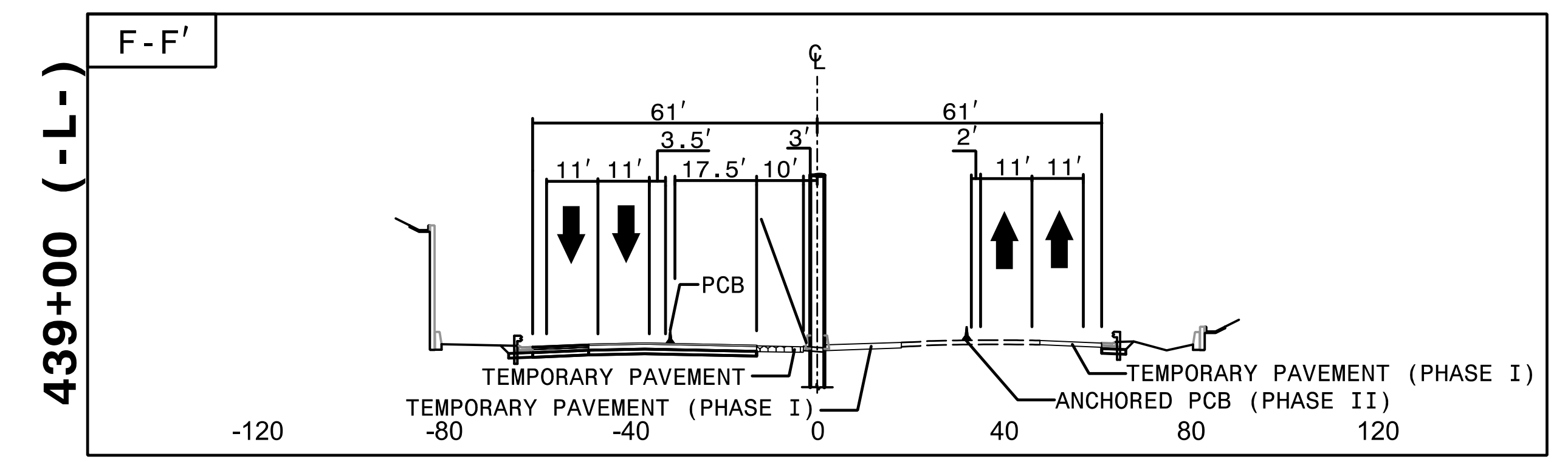
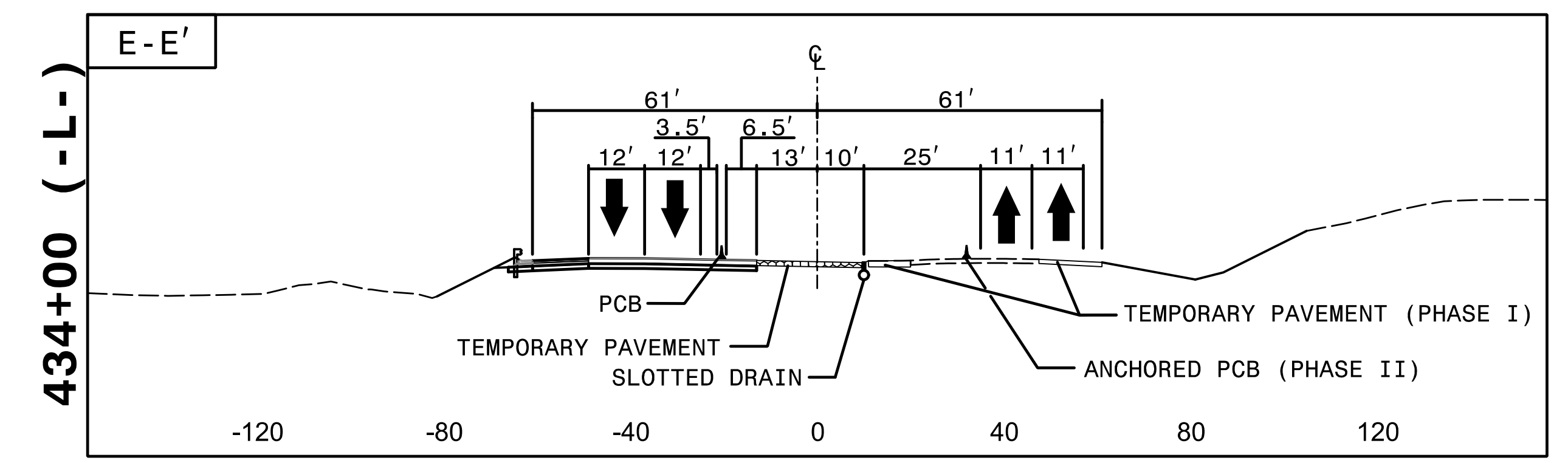
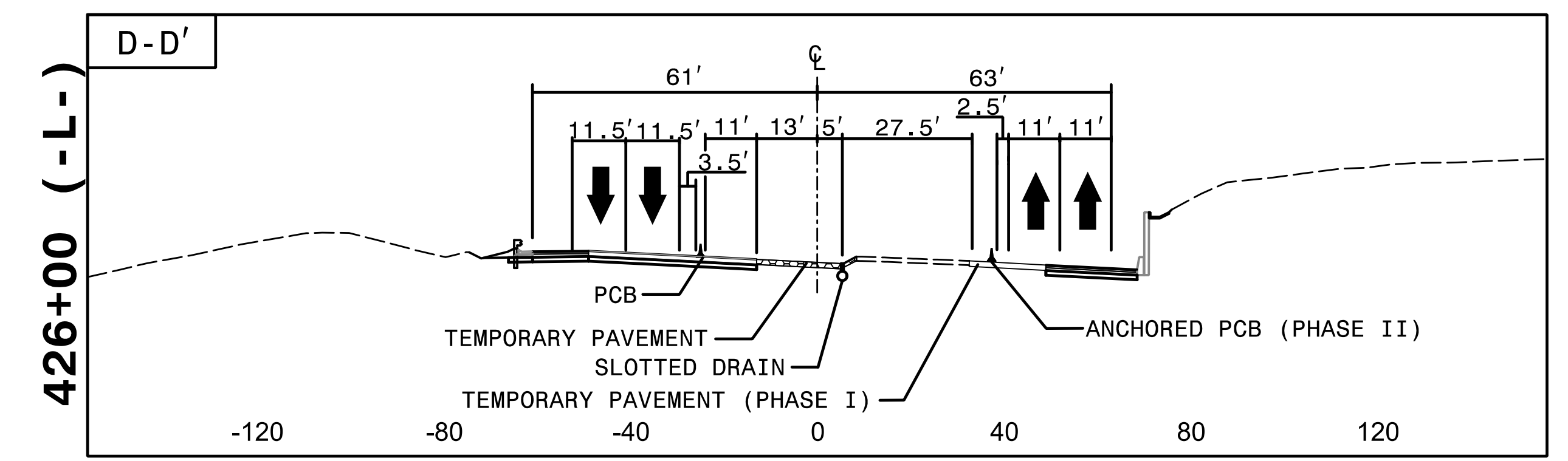
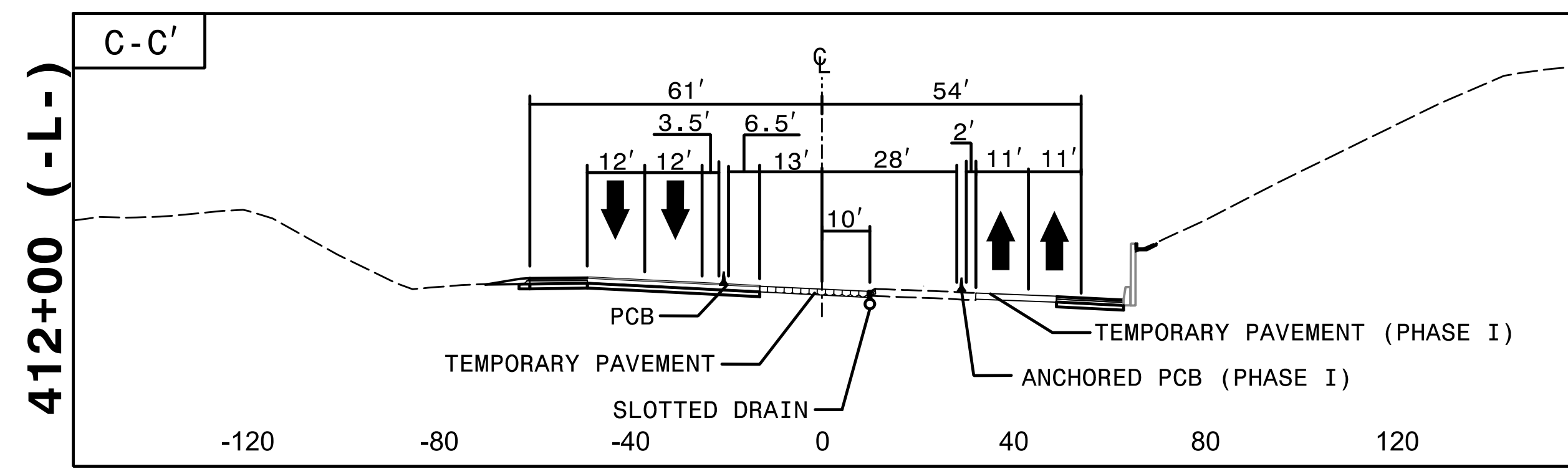
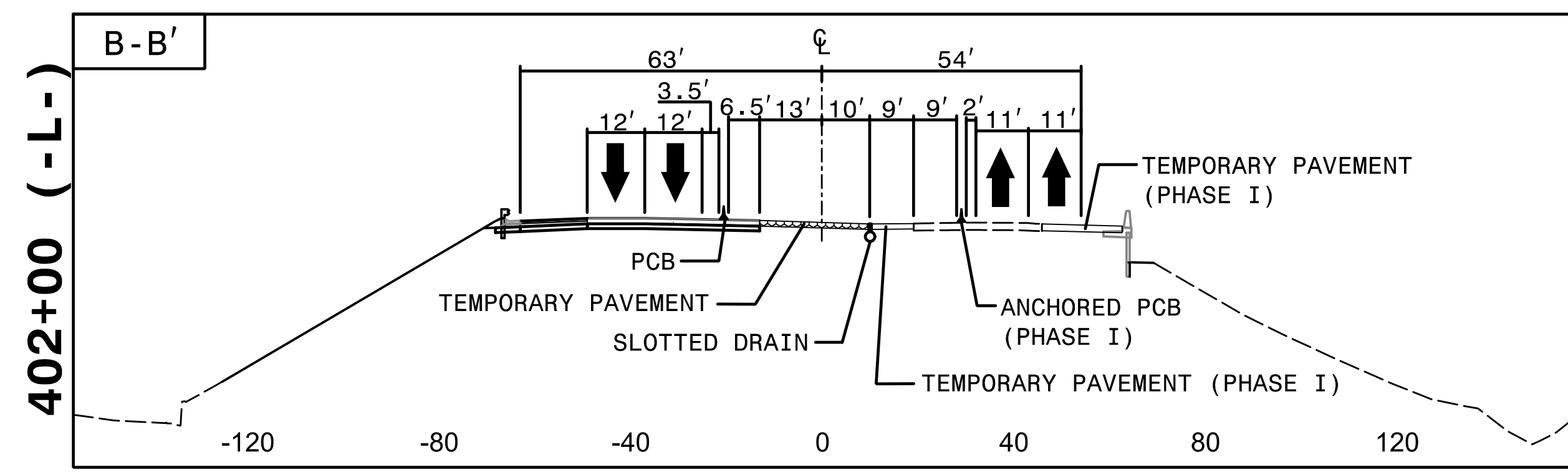
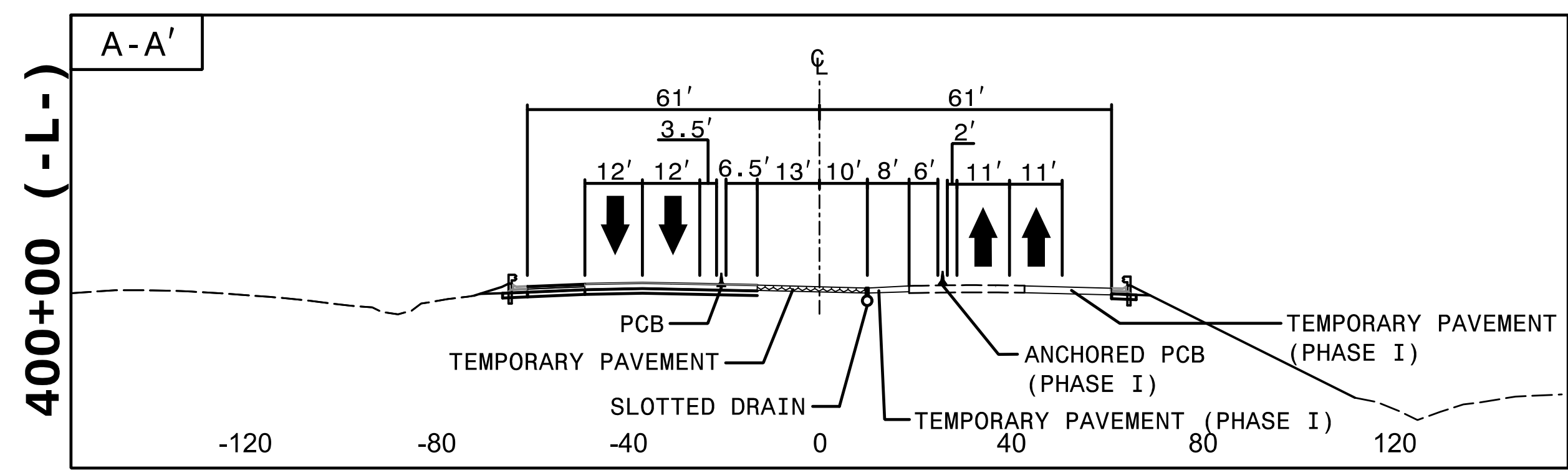

12:58:15 PM  
I:\CP\4400BB\_fc\_p3 CUTS.dgn  
9/3/2019

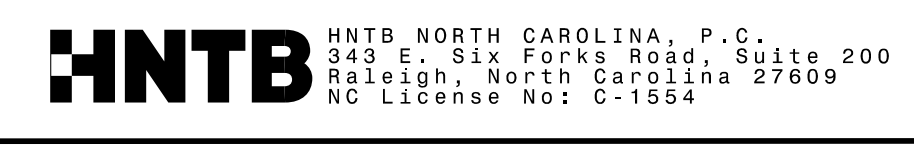

APPROVED: *Rhonda B. Early*  
 DATE: 9/3/2019

PROFESSIONAL ENGINEER  
 SEAL  
 023521  
 RHONDA B. EARLY

DOCUMENT NOT CONSIDERED FINAL  
 UNLESS ALL SIGNATURES COMPLETED

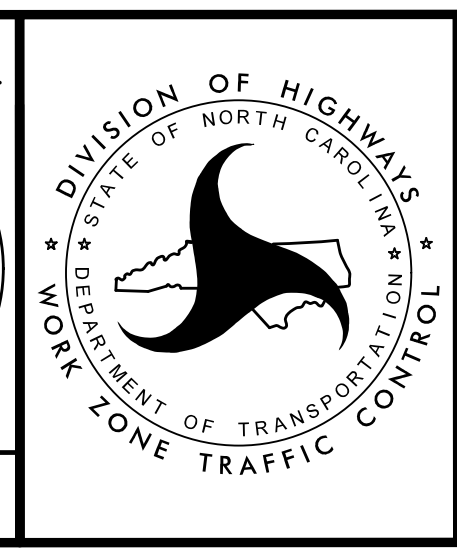

TRANSPORTATION  
 MANAGEMENT PLAN

PHASE III  
 CUT SECTIONS

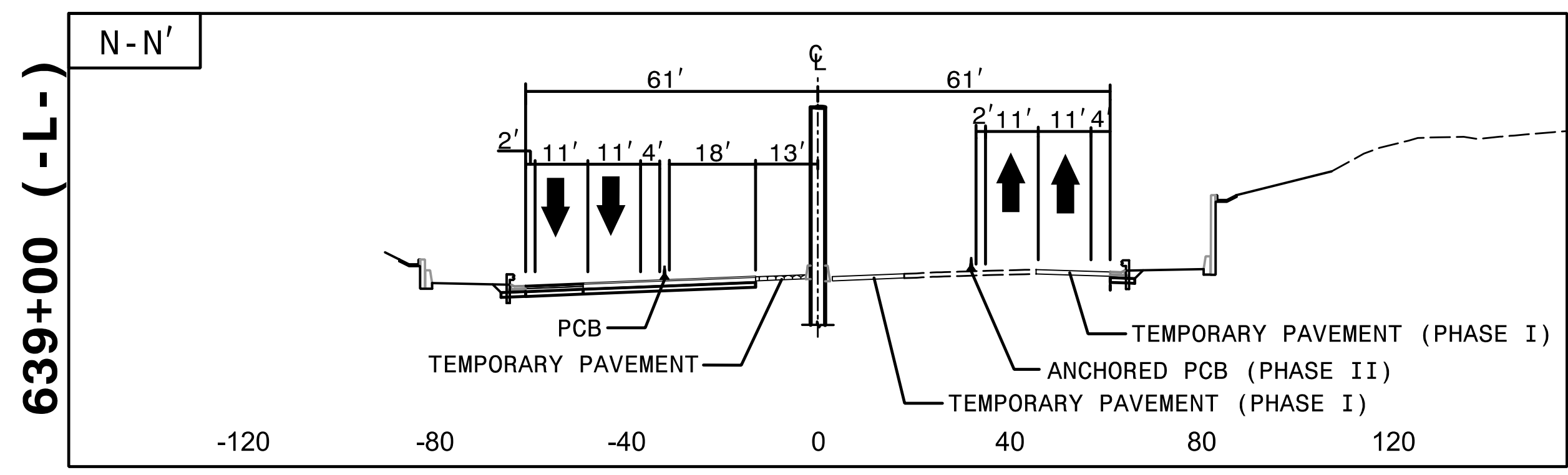
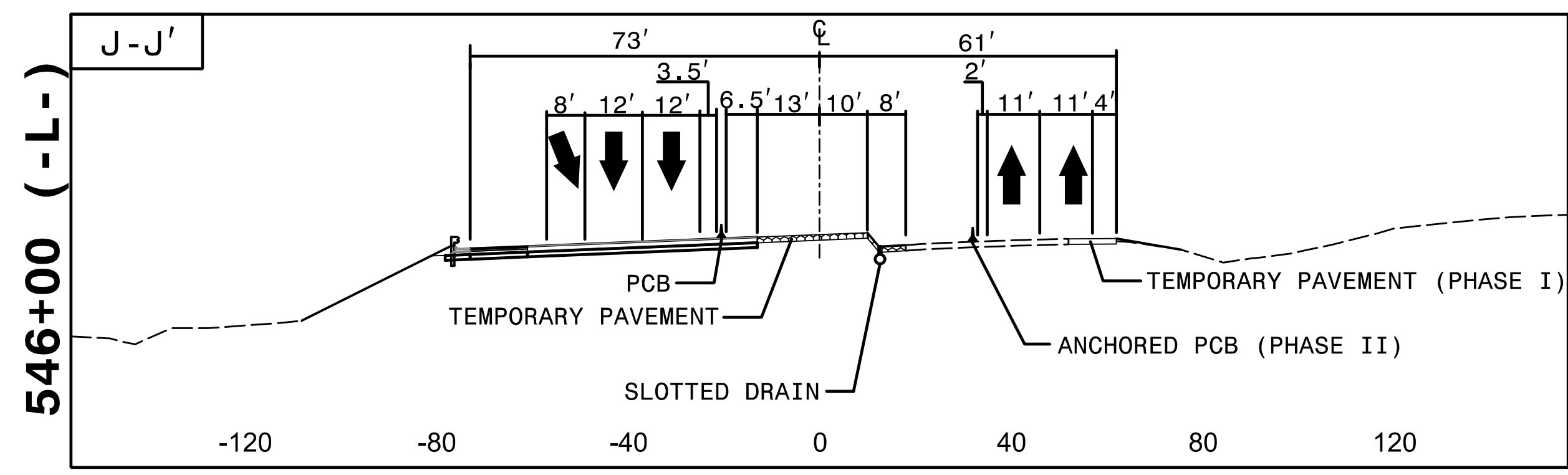
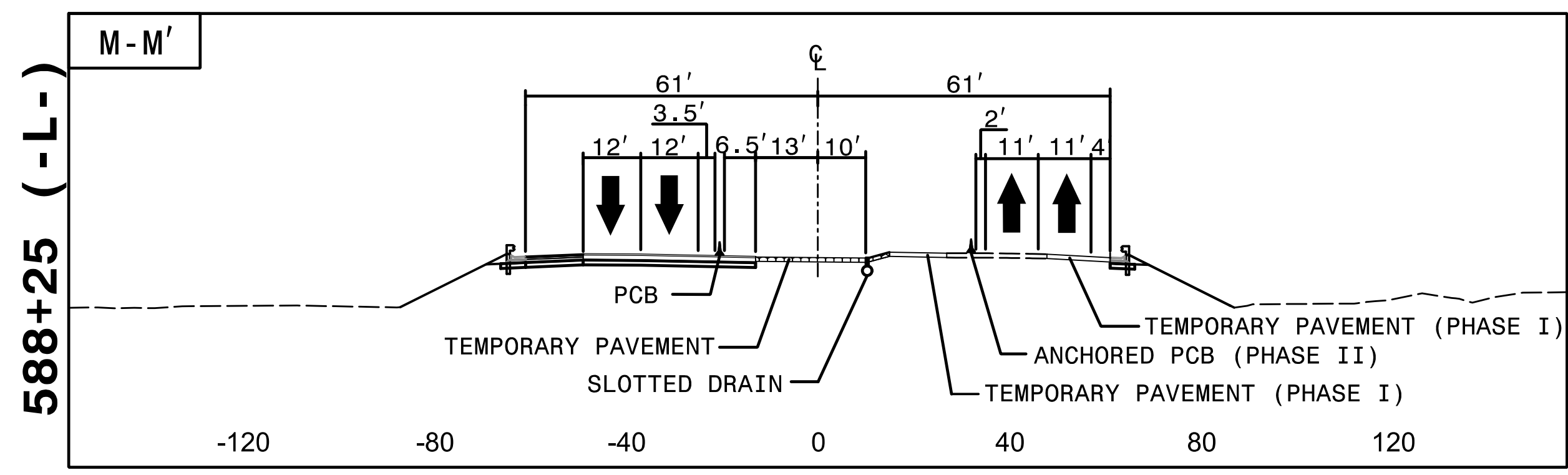
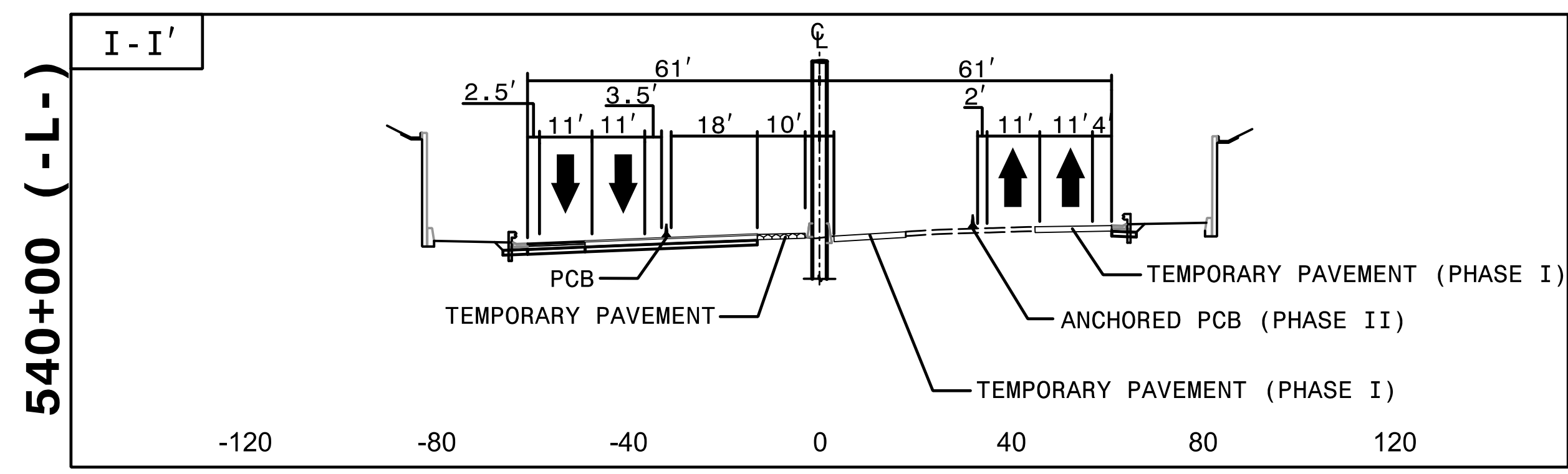
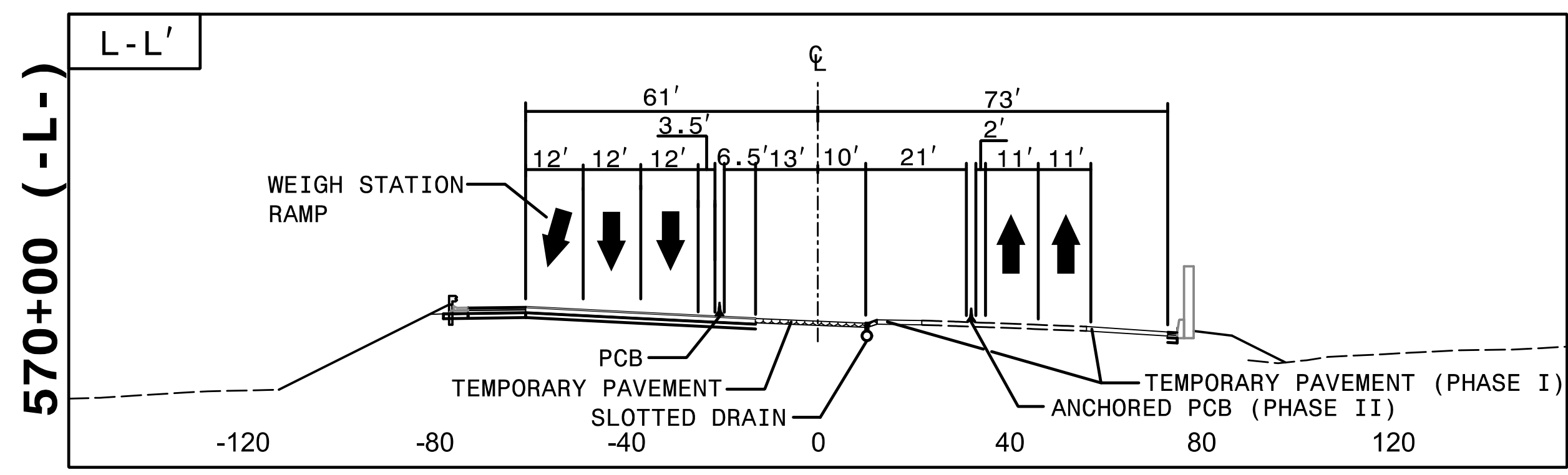
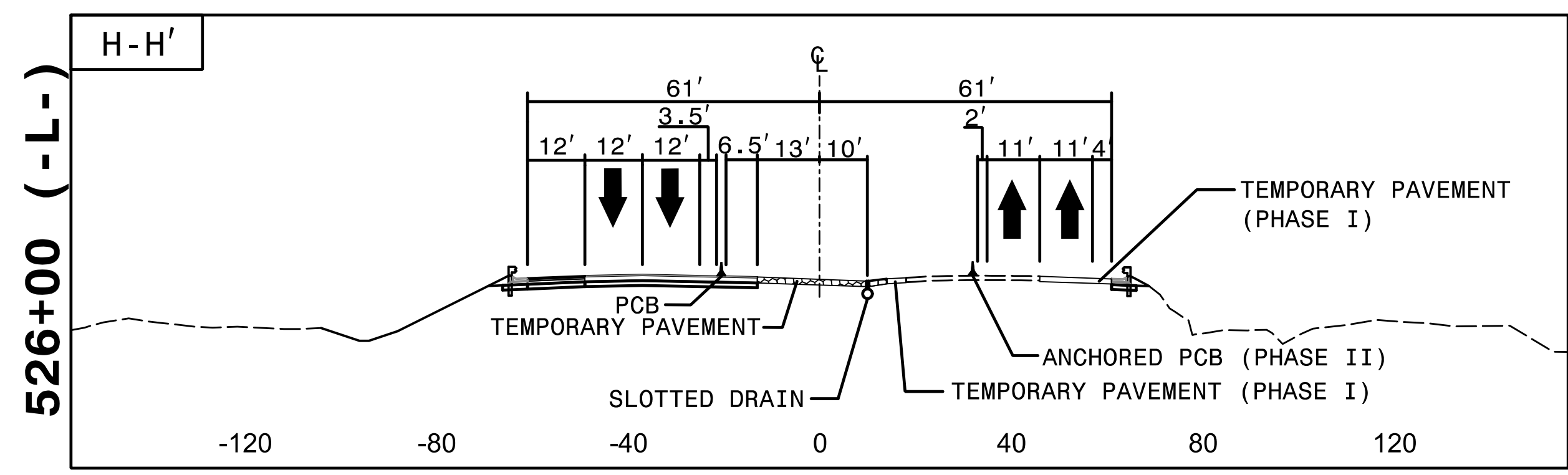
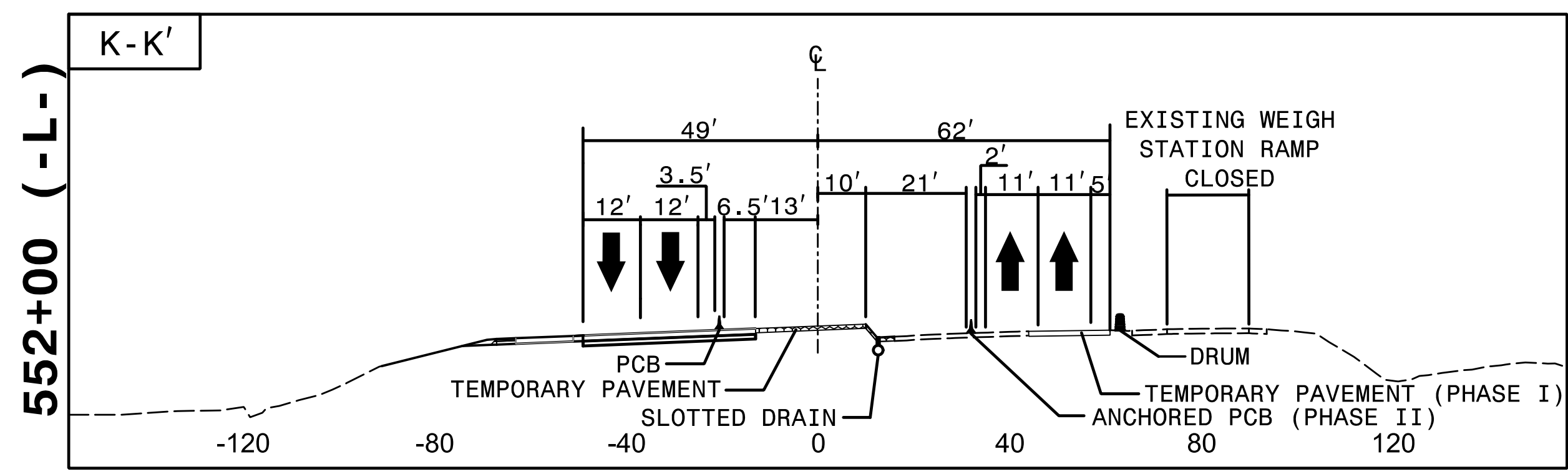
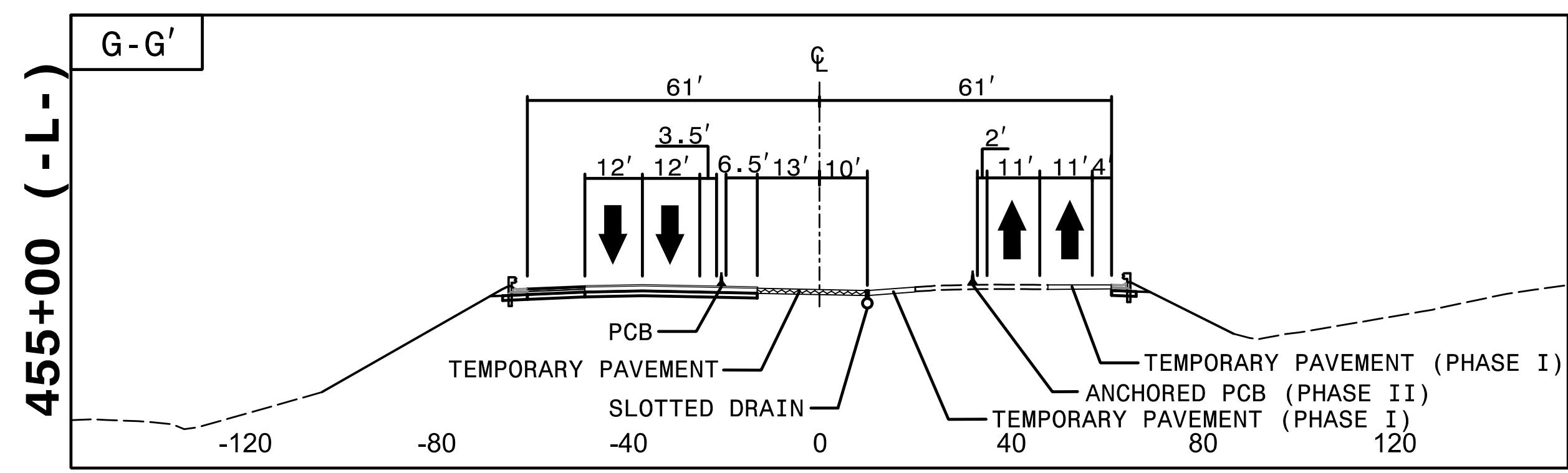

12:58:18 PM  
I:\CP\4400BB\_fc\_p3 CUTS.dgn  
9/3/2019

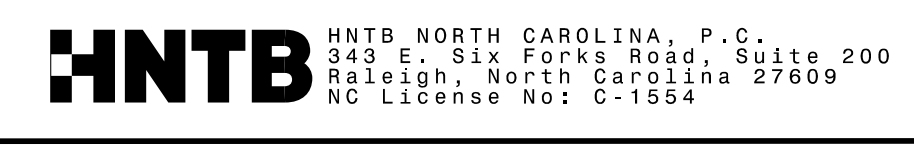

APPROVED: *Rhonda B. Early*  
DATE: 9/3/2019

DocuSigned by:  
Rhonda B. Early  
F34CAF5AC8BF48A

**NORTH CAROLINA**  
PROFESSIONAL  
SEAL  
023521  
ENGINEER  
RHONDA B. EARLY

**DOCUMENT NOT CONSIDERED FINAL  
UNLESS ALL SIGNATURES COMPLETED**



TRANSPORTATION  
MANAGEMENT PLAN

**PHASE III  
CUT SECTIONS**

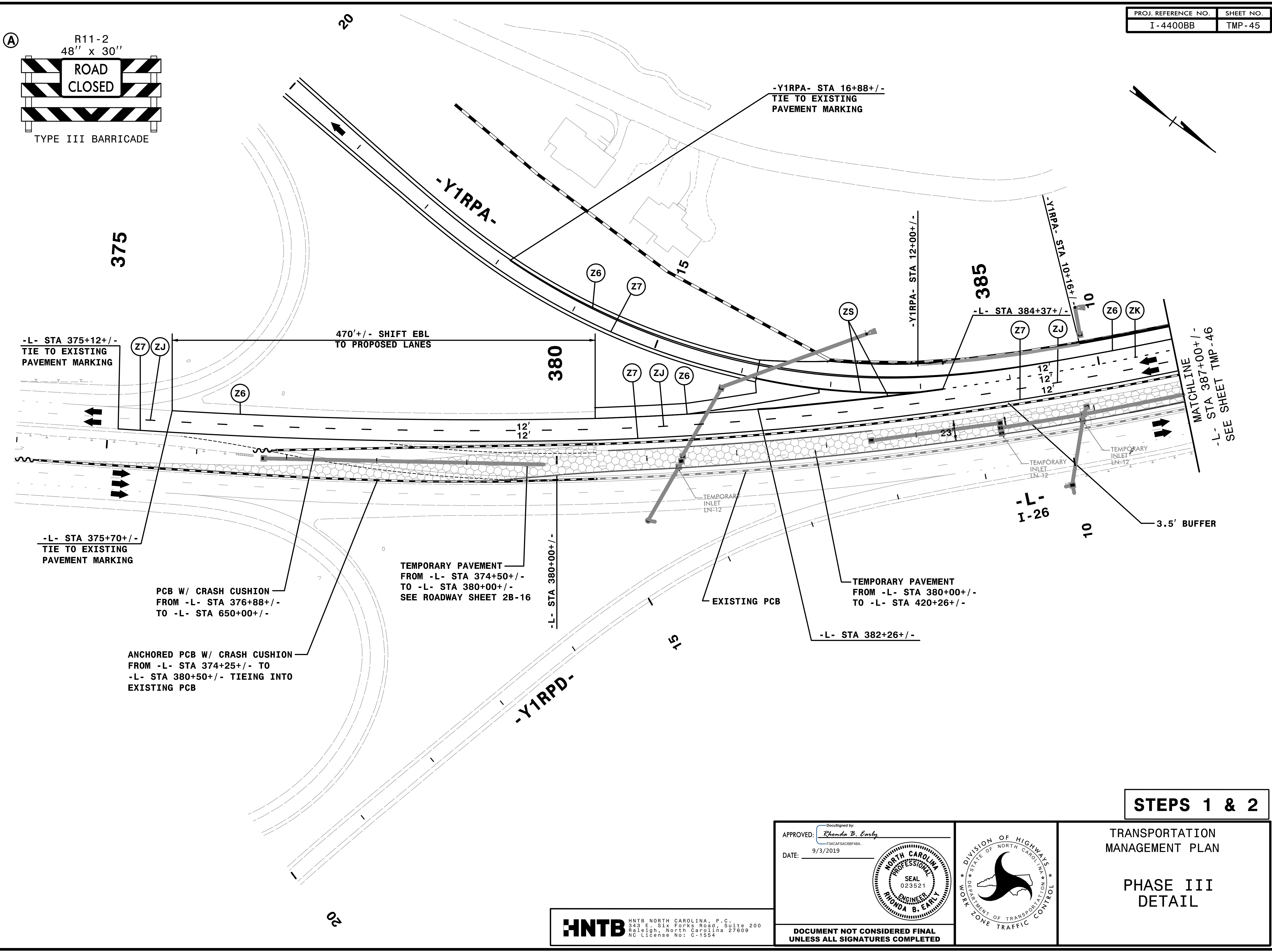
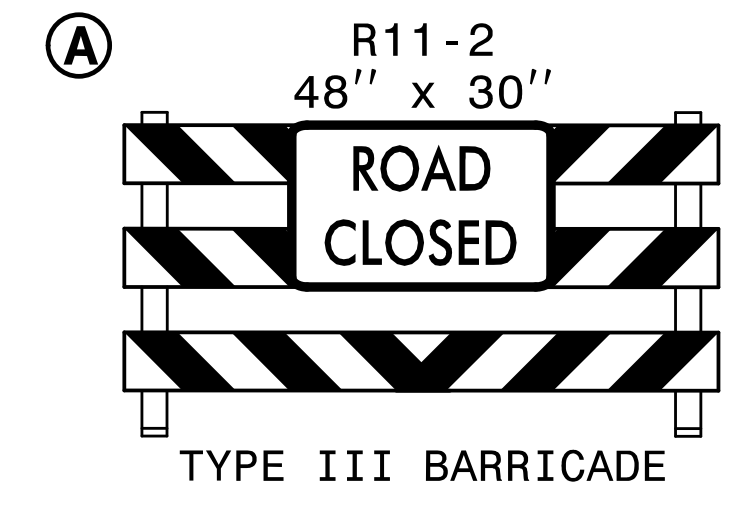

**STEPS 1 & 2**

TRANSPORTATION  
MANAGEMENT PLAN

PHASE III  
DETAIL

APPROVED: *Rhonda B. Early*  
DATE: 9/3/2019

DocuSigned by:  
Rhonda B. Early  
F3MCAF5ACBF48A...

**DOCUMENT NOT CONSIDERED FINAL  
UNLESS ALL SIGNATURES COMPLETED**

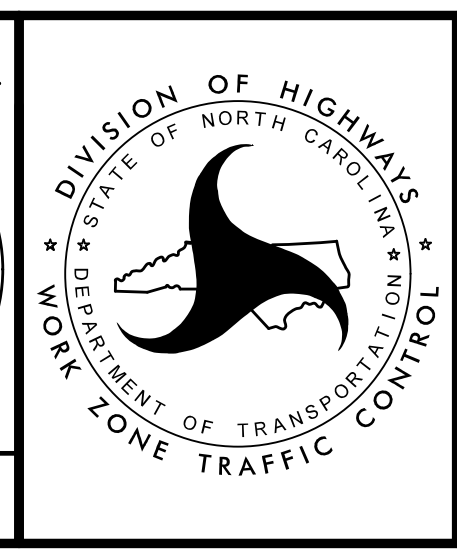

**HNTB** HNTB NORTH CAROLINA, P.C.  
349 E. Six Forks Road, Suite 200  
Raleigh, North Carolina 27609  
NC License No: C-1554

12:58:27 PM  
\\TCN\1-4400BB-1.c. P3D1.dgn  
9/3/2019

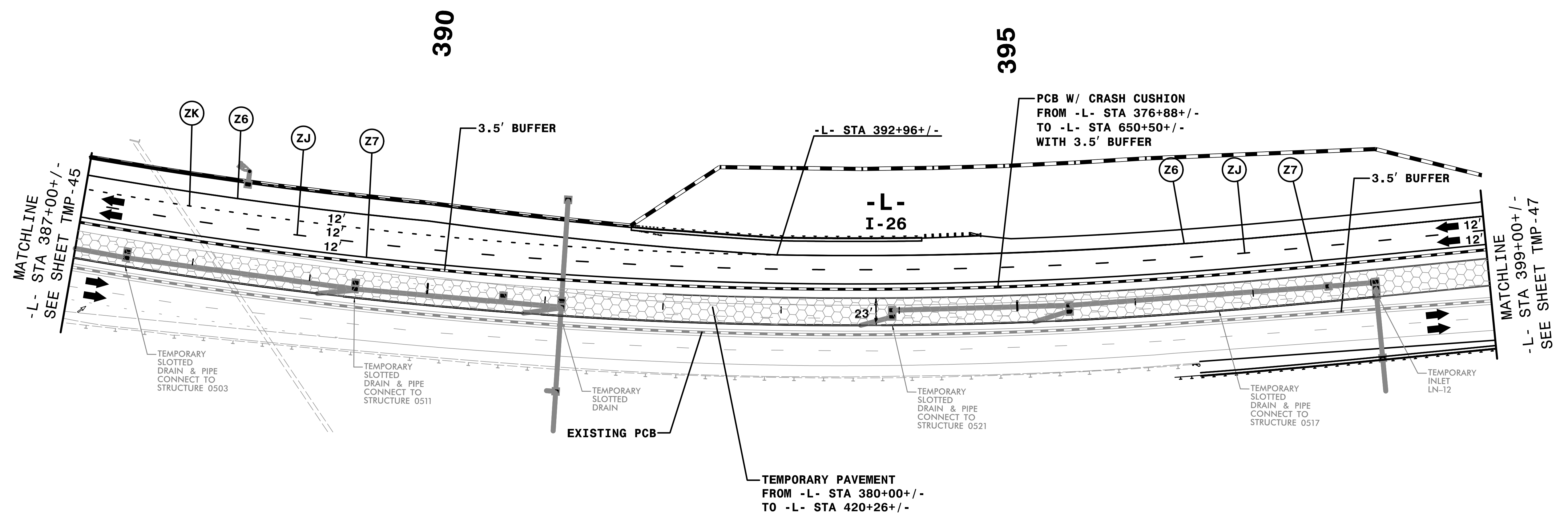
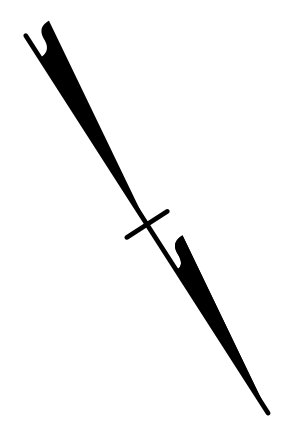

REMOVE CONFLICTING PAVEMENT MARKING.

**STEPS 1 & 2**

TRANSPORTATION  
MANAGEMENT PLAN

PHASE III  
DETAIL

APPROVED: *Rhonda B. Early*  
DocuSigned by:  
Rhonda B. Early  
F34CAF5AC8BF48A...  
 DATE: 9/3/2019

**DOCUMENT NOT CONSIDERED FINAL  
UNLESS ALL SIGNATURES COMPLETED**

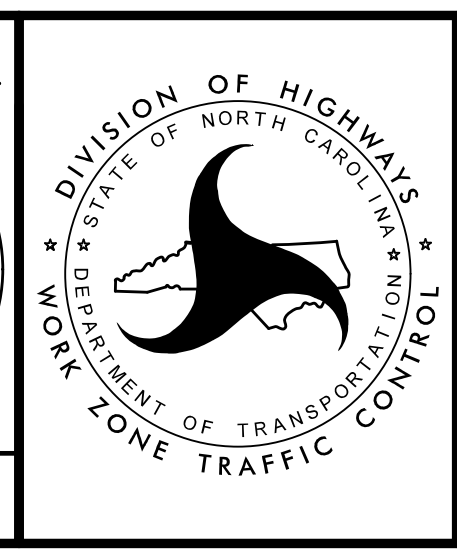

**HNTB** HNTB NORTH CAROLINA, P.C.  
 343 E. Six Forks Road, Suite 200  
 Raleigh, North Carolina 27609  
 NC License No: C-1554

12:58:34 PM  
 I:\CPN\I-4400BB.t.c.P3D2.dgn  
 9/3/2019

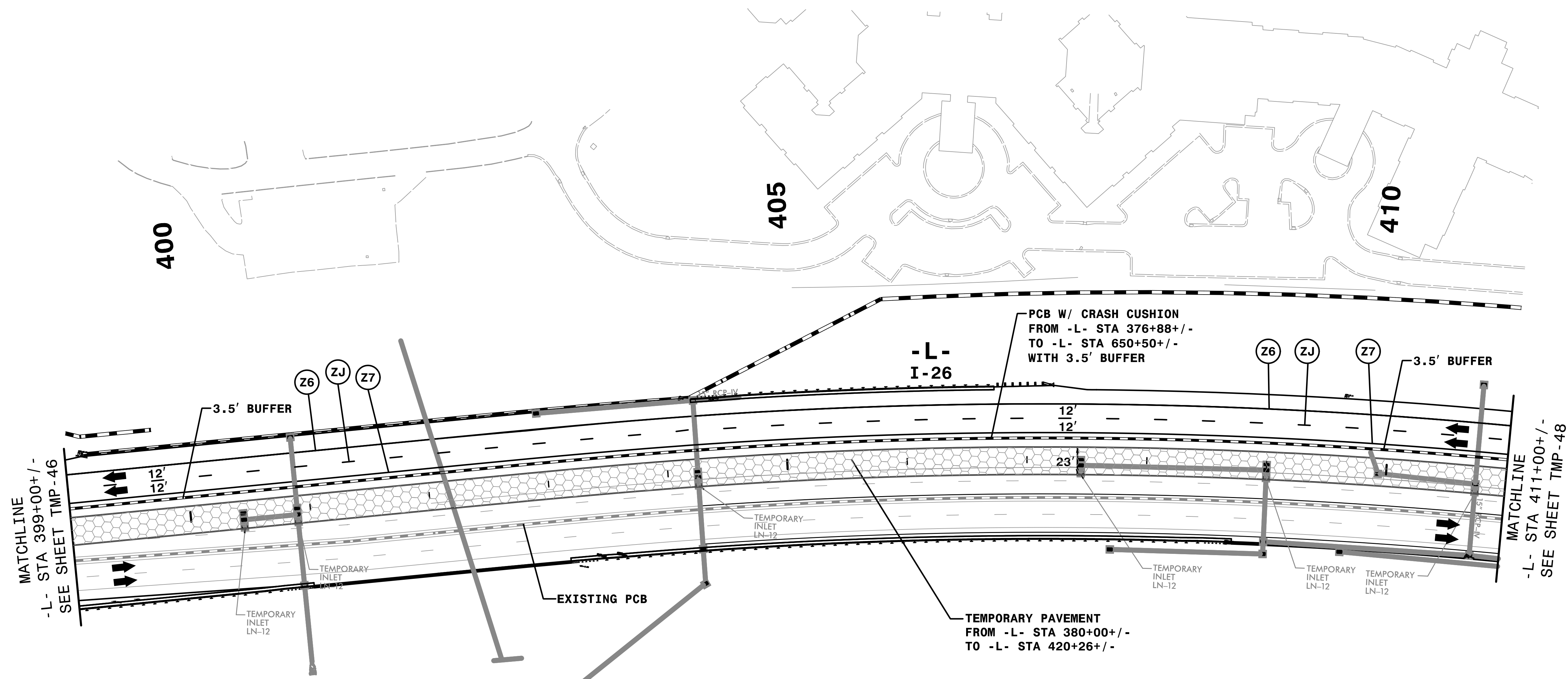

REMOVE CONFLICTING PAVEMENT MARKING.

**STEPS 1 & 2**

TRANSPORTATION  
MANAGEMENT PLAN

PHASE III  
DETAIL

APPROVED: *Rhonda B. Early*  
DocuSigned by:  
Rhonda B. Early  
F3MCAF5ACBF48A...  
 DATE: 9/3/2019

**PROFESSIONAL ENGINEER**  
 NORTH CAROLINA  
 SEAL  
 023521  
 RHONDA B. EARLY

**DOCUMENT NOT CONSIDERED FINAL  
UNLESS ALL SIGNATURES COMPLETED**

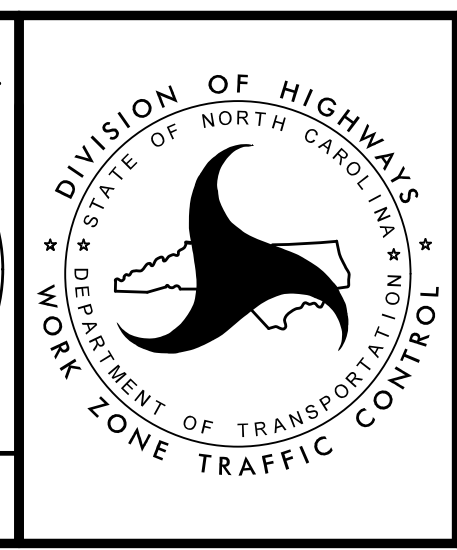

**HNTB** HNTB NORTH CAROLINA, P.C.  
 343 E. Six Forks Road, Suite 200  
 Raleigh, North Carolina 27609  
 NC License No: C-1554

12:58:40 PM  
 I:\CP\I-4400BB.t.c.P3D3.dgn  
 9/3/2019

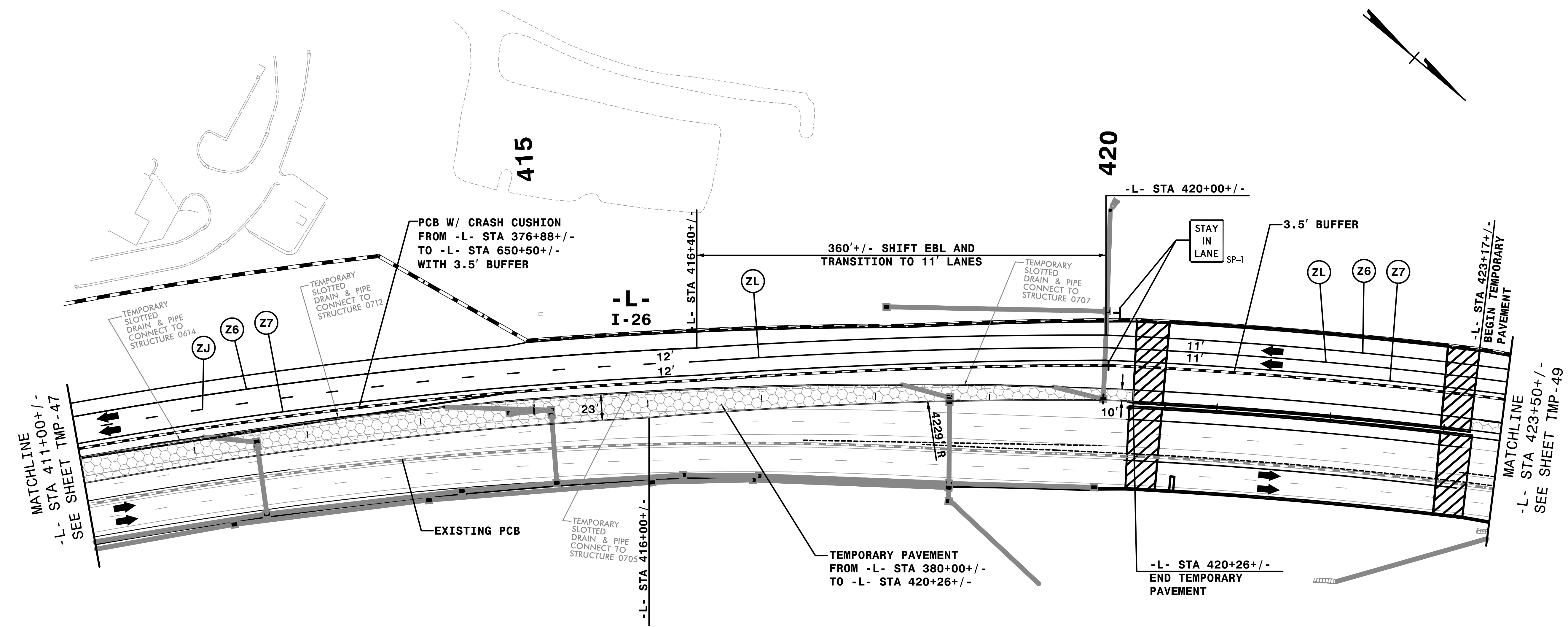

REMOVE CONFLICTING PAVEMENT MARKING.

**STEPS 1 & 2**

TRANSPORTATION  
MANAGEMENT PLAN

PHASE III  
DETAIL

APPROVED: *Rhonda B. Early*  
FSMCAFSACBF48A  
 DATE: 9/3/2019

DocuSigned by:  
*Rhonda B. Early*  
FSMCAFSACBF48A

**NORTH CAROLINA**  
 PROFESSIONAL  
 SEAL  
 023521  
 ENGINEER  
**RHONDA B. EARLY**

**DOCUMENT NOT CONSIDERED FINAL  
UNLESS ALL SIGNATURES COMPLETED**

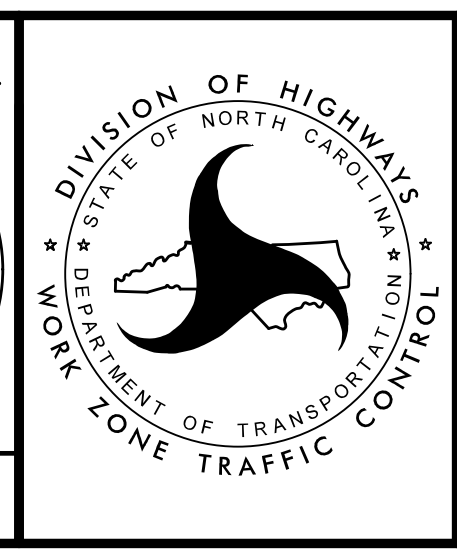

**HNTB** HNTB NORTH CAROLINA, P.C.  
 343 E. Six Forks Road, Suite 200  
 Raleigh, North Carolina 27609  
 NC License No: C-1554

12:58:46 PM  
 \\TCPL-4400BB-t.c.F3D4.dgn  
 9/3/2019



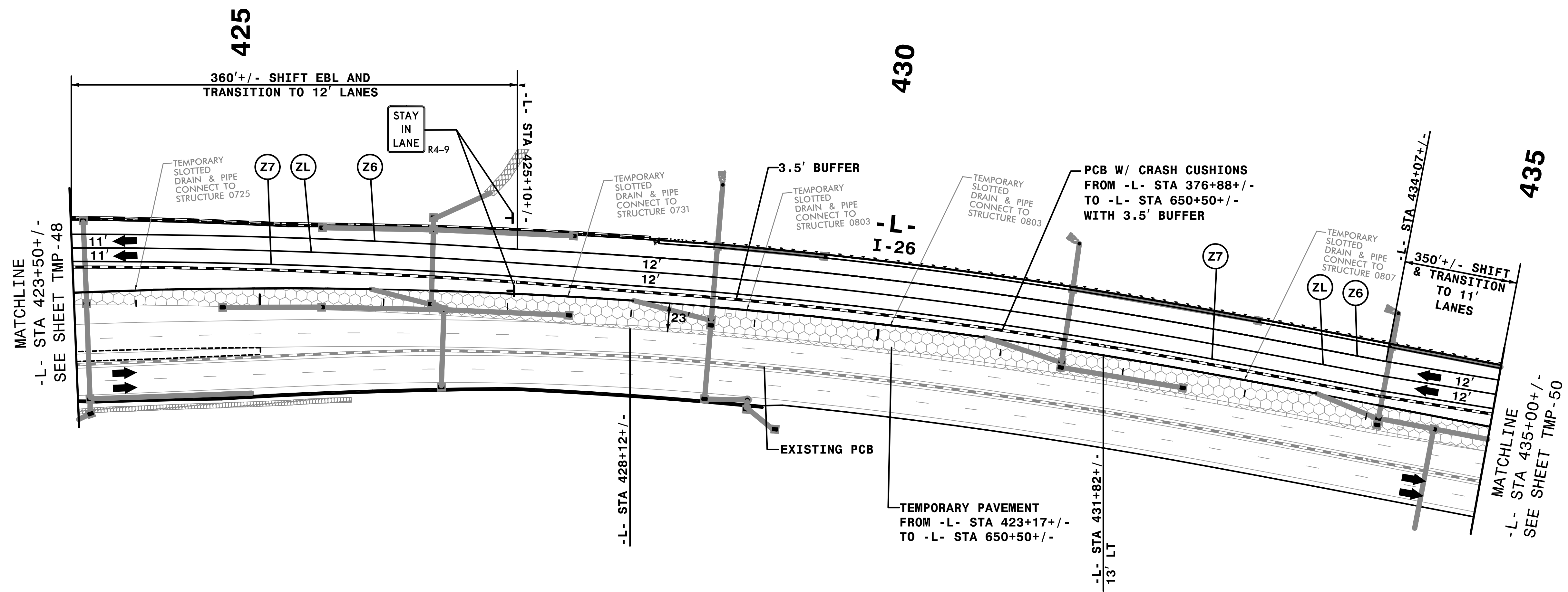
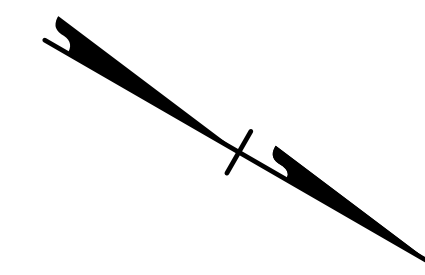

REMOVE CONFLICTING PAVEMENT MARKING.

**STEPS 1 & 2**

TRANSPORTATION MANAGEMENT PLAN

PHASE III  
DETAIL

APPROVED: *Rhonda B. Early*  
FSMCAFSACBF48A  
 DATE: 9/3/2019

**PROFESSIONAL ENGINEER**  
 NORTH CAROLINA  
 SEAL  
 023521  
 RHONDA B. EARLY

**DOCUMENT NOT CONSIDERED FINAL  
UNLESS ALL SIGNATURES COMPLETED**

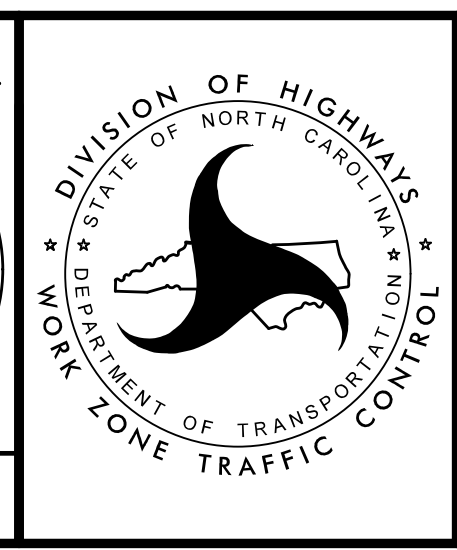

**HNTB** HNTB NORTH CAROLINA, P.C.  
 343 E. Six Forks Road, Suite 200  
 Raleigh, North Carolina 27609  
 NC License No: C-1554

12:58:53 PM  
 \\TCPL-4400BB-1.c. P3D5.dgn  
 9/3/2019

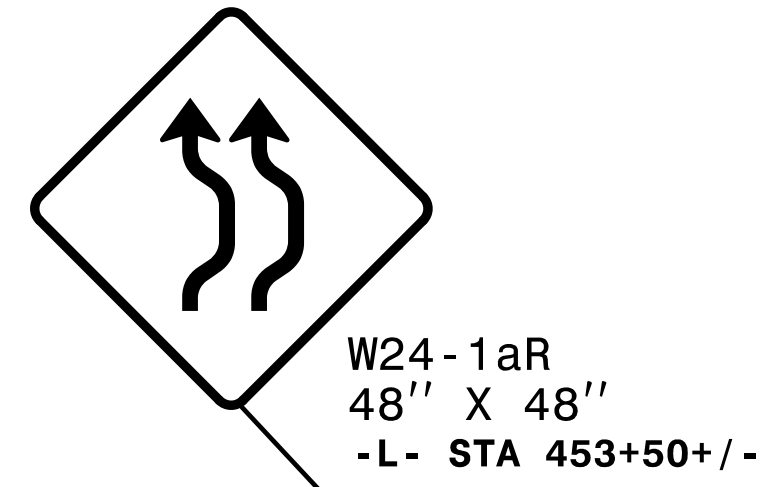
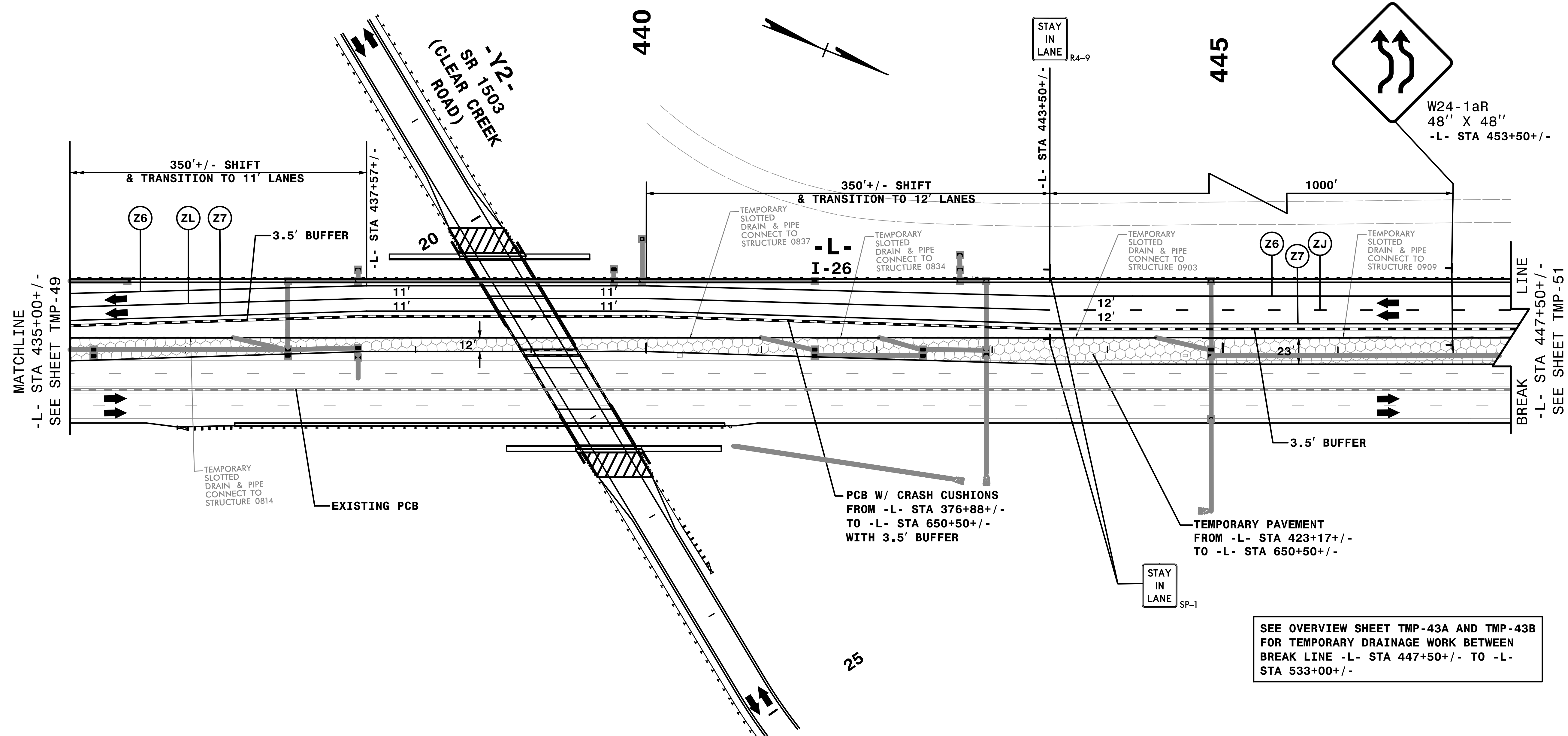

SEE OVERVIEW SHEET TMP-43A AND TMP-43B FOR TEMPORARY DRAINAGE WORK BETWEEN BREAK LINE -L- STA 447+50+/- TO -L- STA 533+00+/-

REMOVE CONFLICTING PAVEMENT MARKING.

**STEPS 1 & 2**

TRANSPORTATION MANAGEMENT PLAN

PHASE III  
DETAIL

9/3/2019  
I:\CPN\4400BB.t.c.P3D6.dgn  
DATE\$\$\$\$\$

**HNTB**  
HNTB NORTH CAROLINA, P.C.  
343 E. SIX FORKS ROAD, SUITE 200  
RALEIGH, NORTH CAROLINA 27609  
NC LICENSE NO: C-1554

APPROVED: *Rhonda B. Early*  
DATE: 9/3/2019

DocuSigned by:  
Rhonda B. Early  
F3MCAF5AC8BF48A...

**NORTH CAROLINA**  
PROFESSIONAL  
SEAL  
023521  
ENGINEER  
RHONDA B. EARLY

**DOCUMENT NOT CONSIDERED FINAL  
UNLESS ALL SIGNATURES COMPLETED**

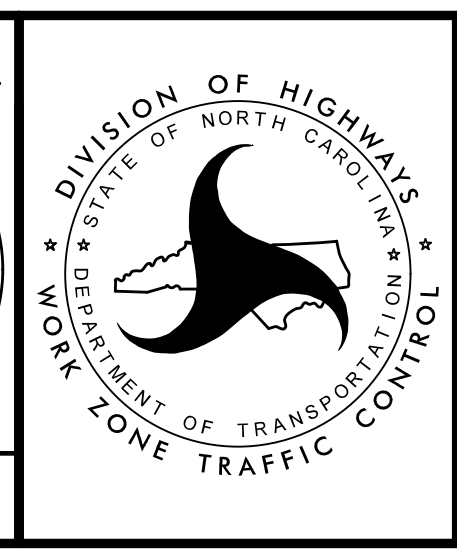

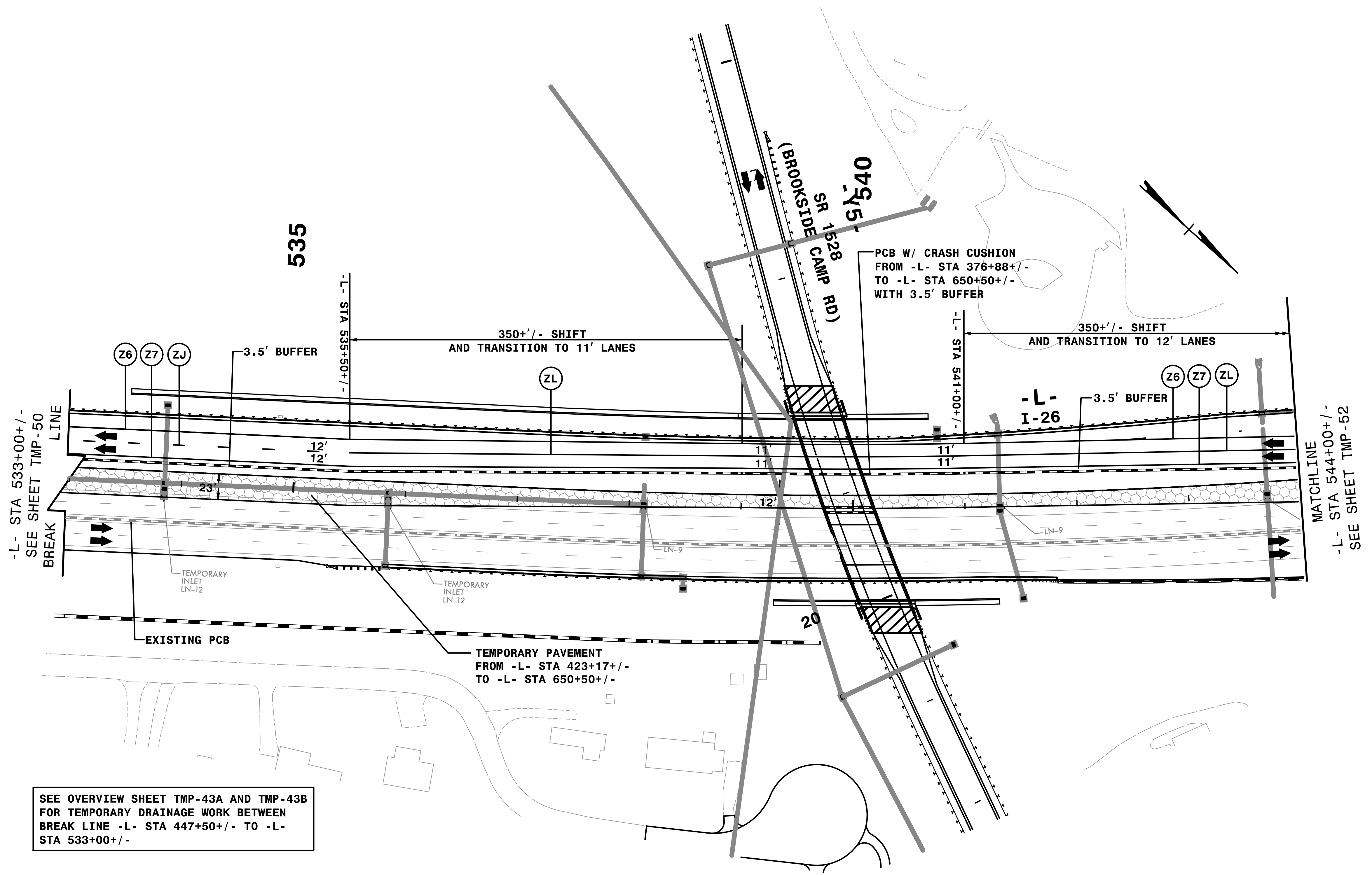

SEE OVERVIEW SHEET TMP-43A AND TMP-43B FOR TEMPORARY DRAINAGE WORK BETWEEN BREAK LINE -L- STA 447+50+/- TO -L- STA 533+00+/-

9/3/2019  
 \*\*\*ICPN-4400BB.t.c.P3D14.dgn  
 \$\$\$DATE\$\$\$

**HNTB** HNTB NORTH CAROLINA, P.C.  
 343 E. Six Forks Road, Suite 200  
 Raleigh, North Carolina 27609  
 NC License No: C-1554

APPROVED: *Rhonda B. Early*  
 F3MCAFACBF48A  
 DATE: 9/3/2019

SEAL  
 NORTH CAROLINA  
 PROFESSIONAL ENGINEER  
 023521  
 RHONDA B. EARLY

DOCUMENT NOT CONSIDERED FINAL UNLESS ALL SIGNATURES COMPLETED



**STEPS 1 & 2**

TRANSPORTATION MANAGEMENT PLAN

PHASE III DETAIL

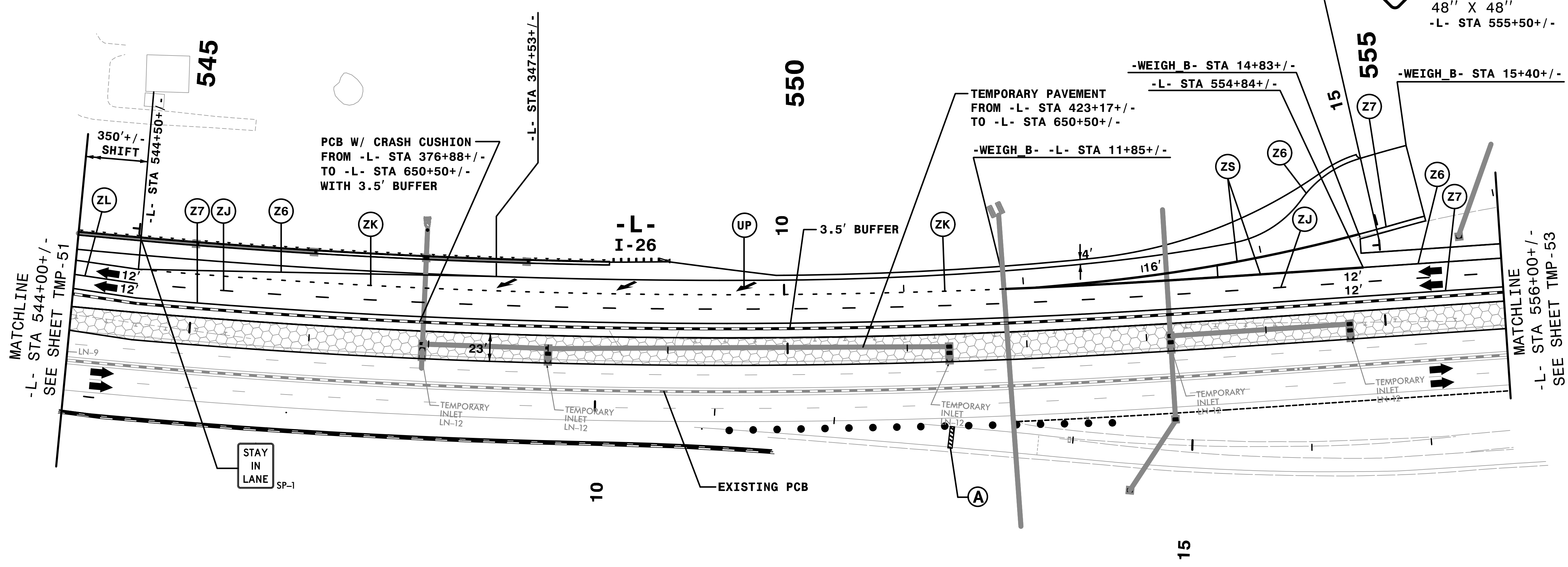
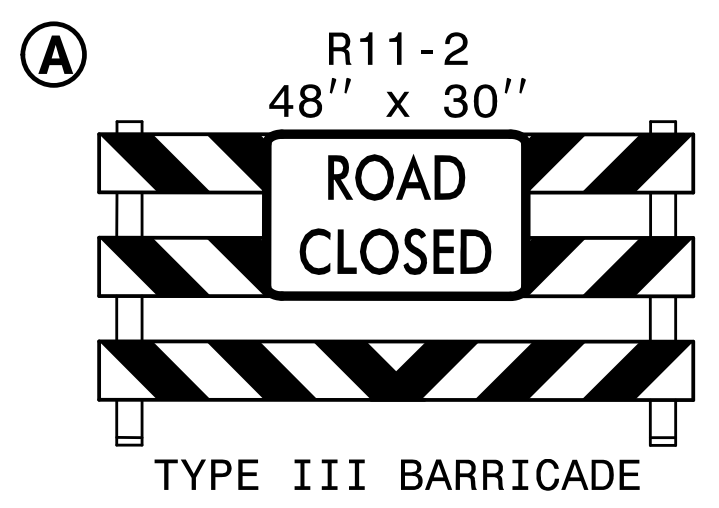

MATCHLINE  
-L- STA 544+00+/-  
SEE SHEET TMP-51

MATCHLINE  
-L- STA 556+00+/-  
SEE SHEET TMP-53

REMOVE CONFLICTING PAVEMENT MARKING.

**STEPS 1 & 2**

TRANSPORTATION  
MANAGEMENT PLAN

PHASE III  
DETAIL

I:\00402 PM  
 \TC\N-4400BB-1.c. P3D15.dgn  
 9/3/2019

**HNTB**  
 HNTB NORTH CAROLINA, P.C.  
 343 E. Six Forks Road, Suite 200  
 Raleigh, North Carolina 27609  
 NC License No: C-1554

APPROVED: *Rhonda B. Early*  
 DATE: 9/3/2019

DocuSigned by:  
 Rhonda B. Early  
 F3MCAF5ACBF48A

**NORTH CAROLINA**  
 PROFESSIONAL  
 SEAL  
 023521  
**RHONDA B. EARLY**  
 ENGINEER

**DOCUMENT NOT CONSIDERED FINAL  
 UNLESS ALL SIGNATURES COMPLETED**

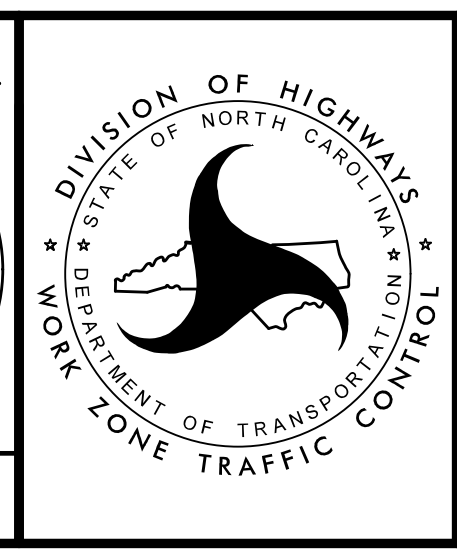

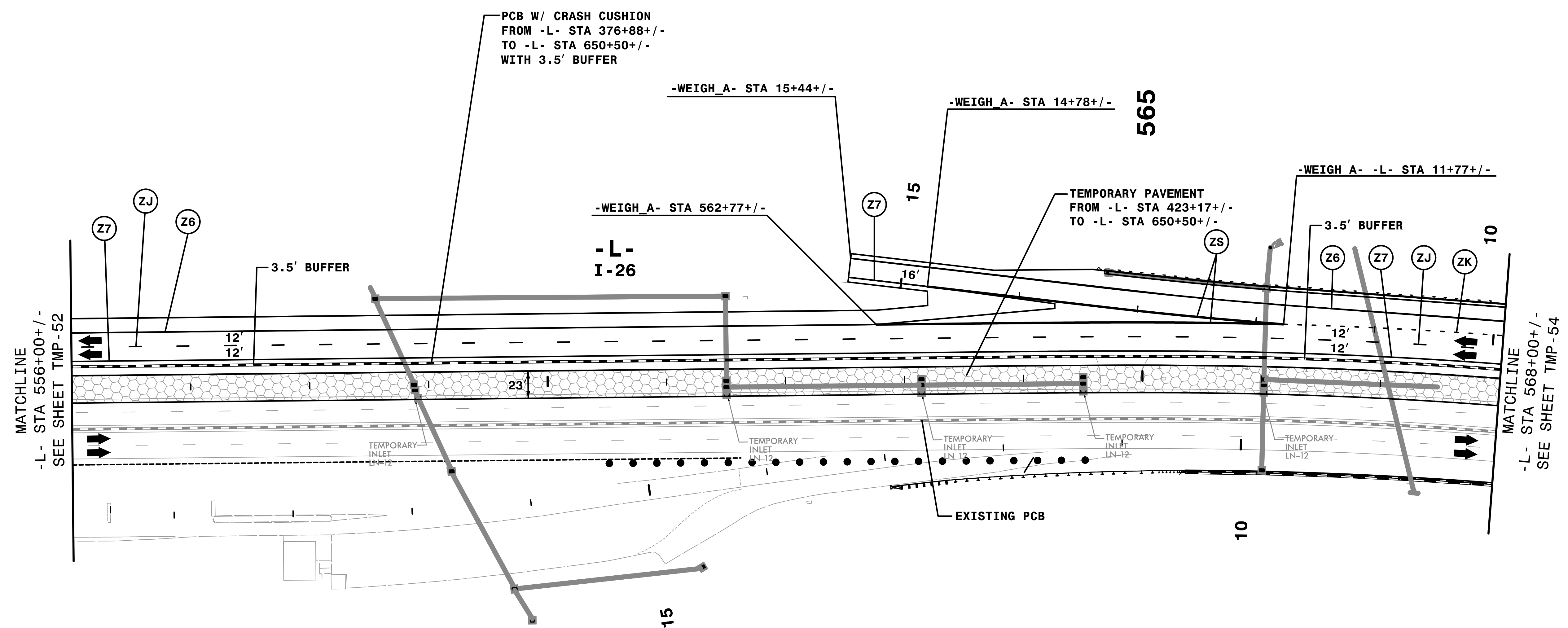
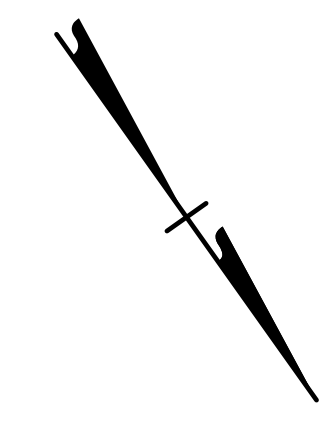

MATCHLINE  
-L- STA 556+00+/-  
SEE SHEET TMP-52

MATCHLINE  
-L- STA 568+00+/-  
SEE SHEET TMP-54

REMOVE CONFLICTING PAVEMENT MARKING.

**STEPS 1 & 2**

TRANSPORTATION  
MANAGEMENT PLAN

PHASE III  
DETAIL

APPROVED: *Rhonda B. Early*  
DATE: 9/3/2019

DocuSigned by:  
Rhonda B. Early  
F3MCAF5AC8BF48A

SEAL  
023521  
NORTH CAROLINA  
PROFESSIONAL  
ENGINEERS  
RHONDA B. EARLY

**DOCUMENT NOT CONSIDERED FINAL  
UNLESS ALL SIGNATURES COMPLETED**

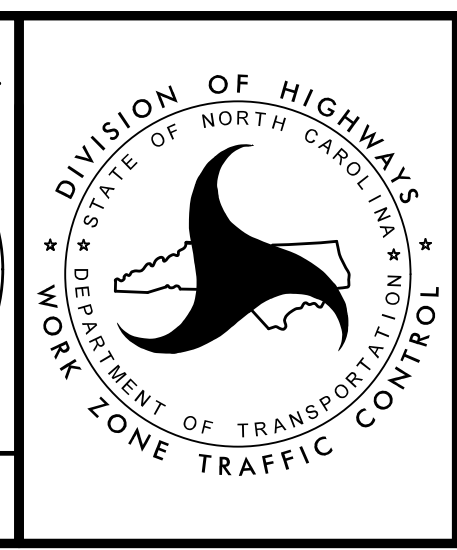

**HNTB** HNTB NORTH CAROLINA, P.C.  
343 E. Six Forks Road, Suite 200  
Raleigh, North Carolina 27609  
NC License No: C-1554

I:\00408 PM  
 I-4400BB-1.c  
 P3D16.dgn  
 9/3/2019

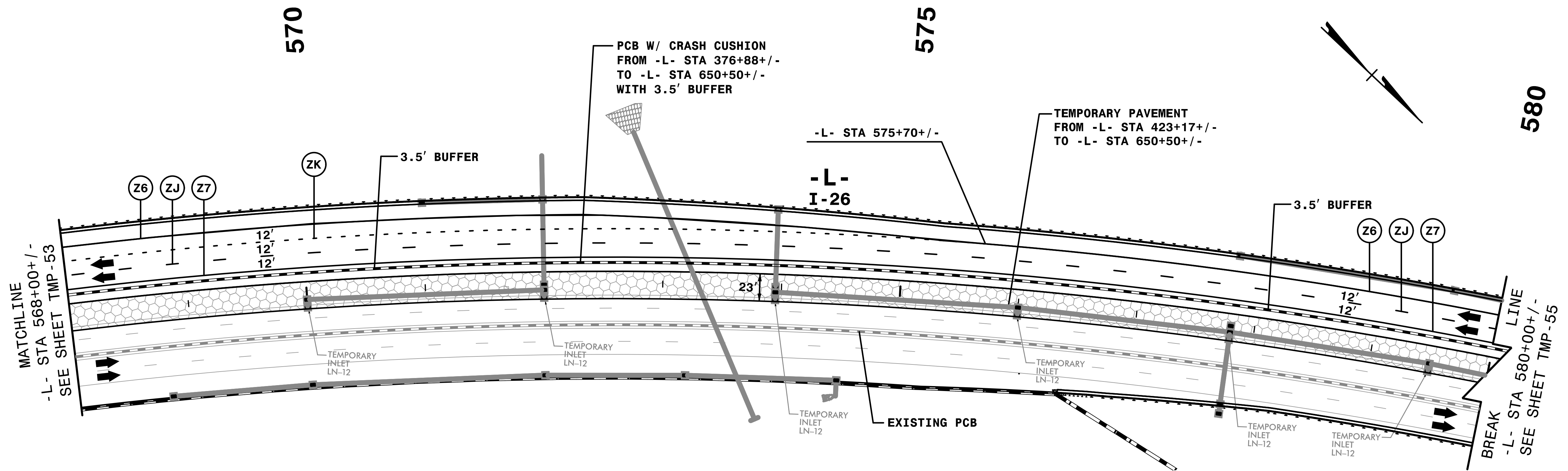

SEE OVERVIEW SHEET TMP-43C AND TMP-43D FOR TEMPORARY DRAINAGE WORK BETWEEN BREAK LINE -L- STA 580+00+/- TO -L- STA 627+00+/-

**STEPS 1 & 2**

TRANSPORTATION MANAGEMENT PLAN

PHASE III DETAIL

9/3/2019  
 \*\*\*ICPN-4400BB.t.c.P3D17.dgn  
 \$\$\$DATE\$\$\$

**HNTB** HNTB NORTH CAROLINA, P.C.  
 343 E. Six Forks Road, Suite 200  
 Raleigh, North Carolina 27609  
 NC License No: C-1554

APPROVED: *Rhonda B. Early*  
 DATE: 9/3/2019

DocuSigned by:  
 Rhonda B. Early  
 F3MCAF5ACBF48A...

9/3/2019

**NORTH CAROLINA**  
 PROFESSIONAL  
 SEAL  
 023521  
 ENGINEER  
 RHONDA B. EARLY

**DOCUMENT NOT CONSIDERED FINAL UNLESS ALL SIGNATURES COMPLETED**



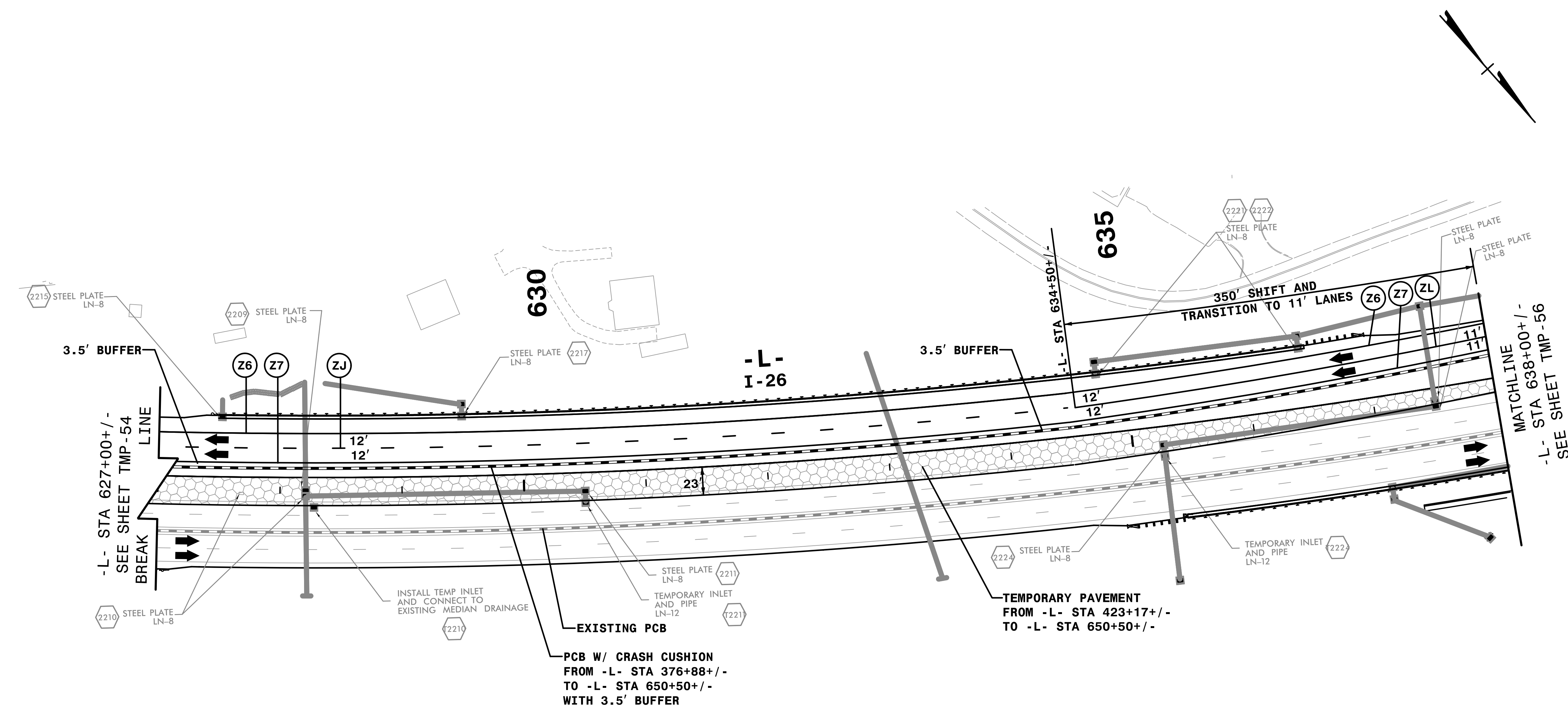

SEE OVERVIEW SHEET TMP-43C AND TMP-43D FOR TEMPORARY DRAINAGE WORK BETWEEN BREAK LINE -L- STA 580+00+/- TO -L- STA 627+00+/-.

- REMOVE CONFLICTING PAVEMENT MARKING.
- SEE PMP FOR PAVMENT MARKING STATIONS.

**STEPS 1 & 2**

TRANSPORTATION MANAGEMENT PLAN

PHASE III DETAIL

APPROVED: *Rhonda B. Early*  
 DATE: 9/3/2019

DocuSigned by:  
 Rhonda B. Early  
 F3MCAFSACBF48A

2019 SEP 03 10:52 AM

**PROFESSIONAL ENGINEER**  
 NORTH CAROLINA  
 SEAL  
 023521  
 RHONDA B. EARLY

**DOCUMENT NOT CONSIDERED FINAL UNLESS ALL SIGNATURES COMPLETED**

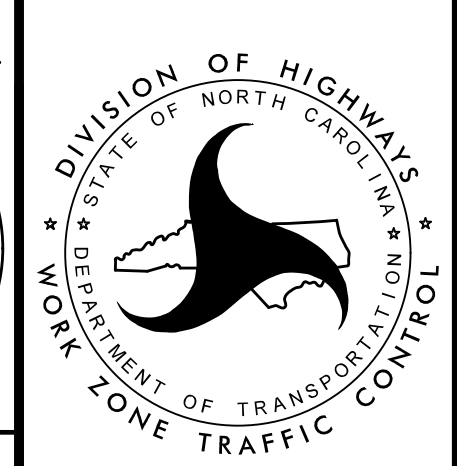

**HNTB** HNTB NORTH CAROLINA, P.C.  
 343 E. Six Forks Road, Suite 200  
 Raleigh, North Carolina 27609  
 NC License No: C-1554

9/3/2019  
 ICPN-4400BB.t.c.P3D22.dgn  
 \$\$\$DATE\$\$\$

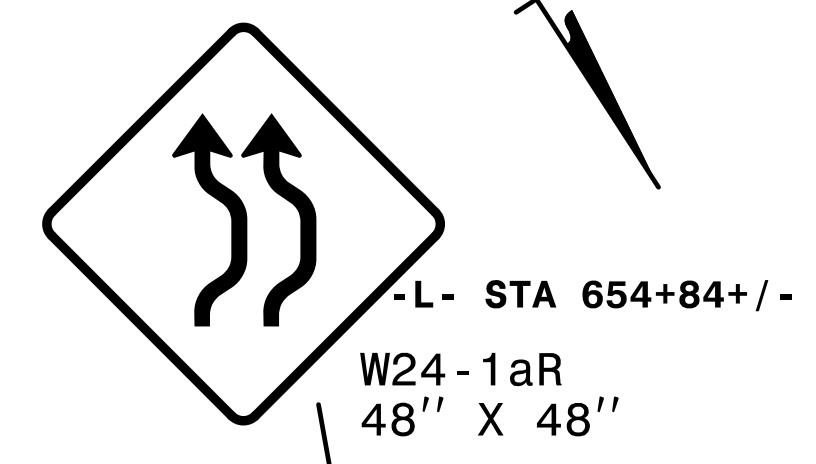
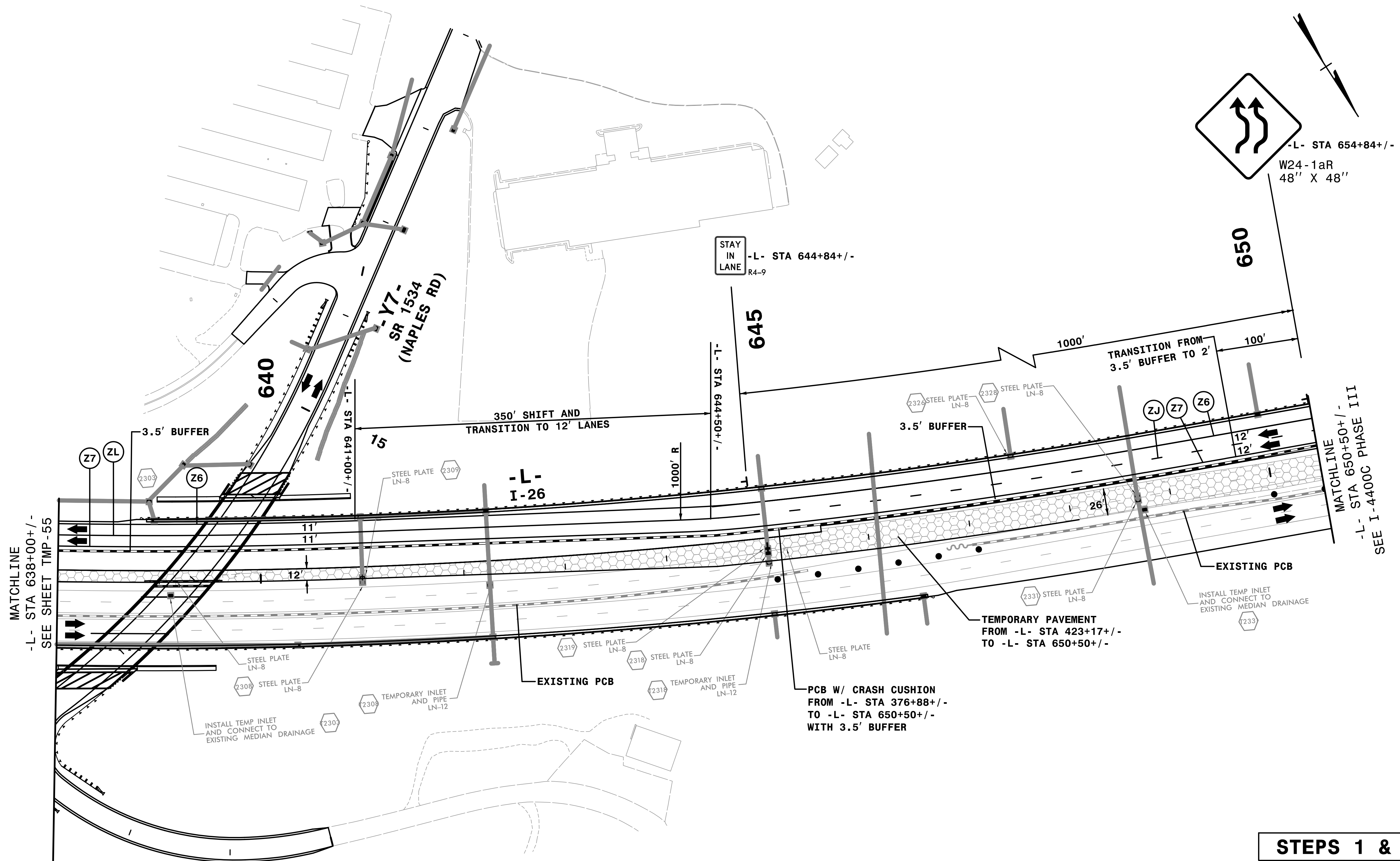

MATCHLINE  
-L- STA 638+00+/-  
SEE SHEET TMP-55

MATCHLINE  
-L- STA 650+50+/-  
SEE I-4400C PHASE III

**STEPS 1 & 2**

TRANSPORTATION  
MANAGEMENT PLAN

PHASE III  
DETAIL

APPROVED: *Rhonda B. Early*  
DATE: 9/3/2019

DocuSigned by:  
Rhonda B. Early  
F3MCAFSACBF48A

SEAL  
023521  
PHONDA B. EARLY  
ENGINEER

**DOCUMENT NOT CONSIDERED FINAL  
UNLESS ALL SIGNATURES COMPLETED**

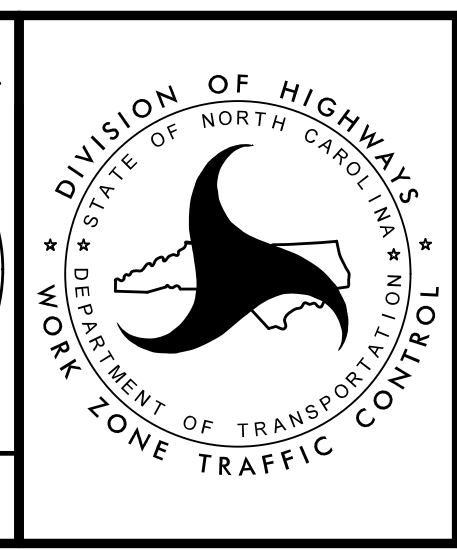

**HNTB** HNTB NORTH CAROLINA, P.C.  
343 E. Six Forks Road, Suite 200  
Raleigh, North Carolina 27609  
NC License No: C-1554

I:\0147\_PM  
I-4400BB-1.c. P3D23.dgn  
9/3/2019



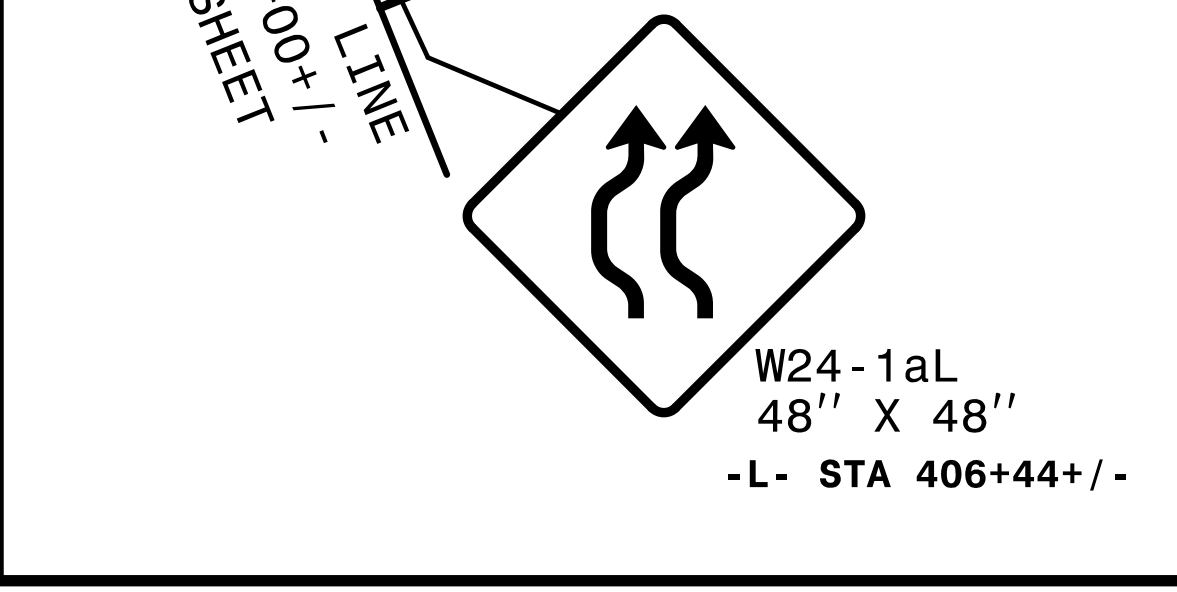
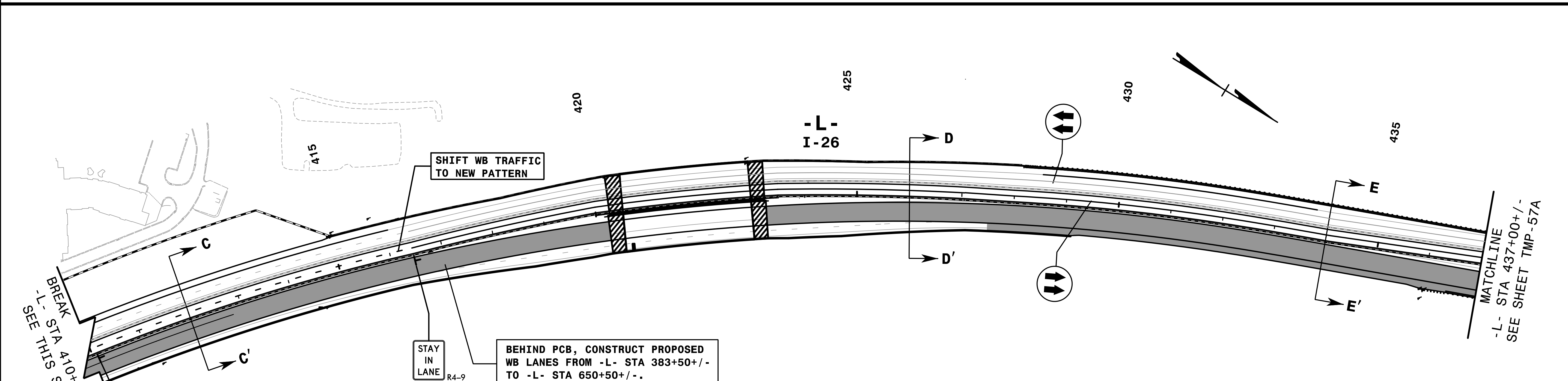
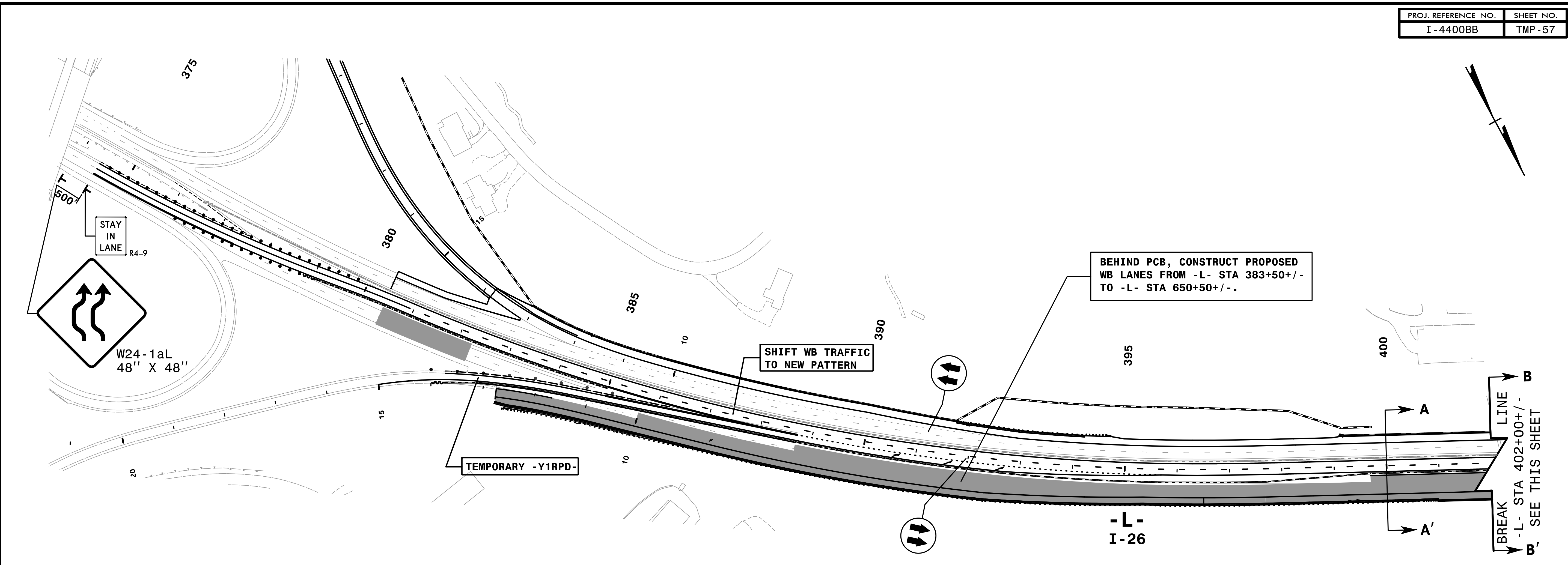

REFER TO SHEET TMP-58 FOR CUT SECTIONS.



APPROVED: *Rhonda B. Early*  
F34CAFAC8BF48A

DATE: 9/3/2019

DocuSigned by:  
Rhonda B. Early

PROFESSIONAL ENGINEER  
SEAL  
023521  
RHONDA B. EARLY

**DOCUMENT NOT CONSIDERED FINAL  
UNLESS ALL SIGNATURES COMPLETED**

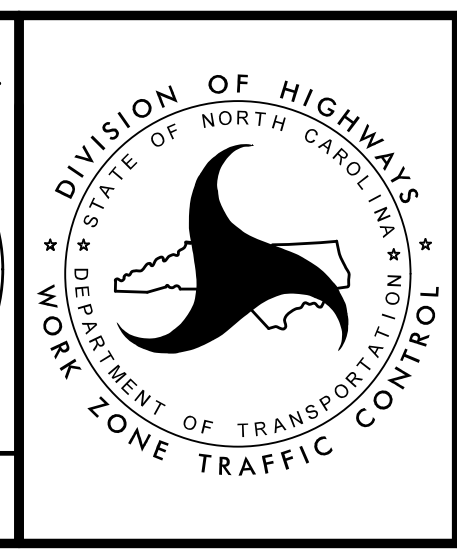

TRANSPORTATION  
MANAGEMENT PLAN

PHASE IV  
OVERVIEW

10:51:26 PM  
 ...:\TrafficControl\TCP\OV.p4.L.dgn  
 9/3/2019

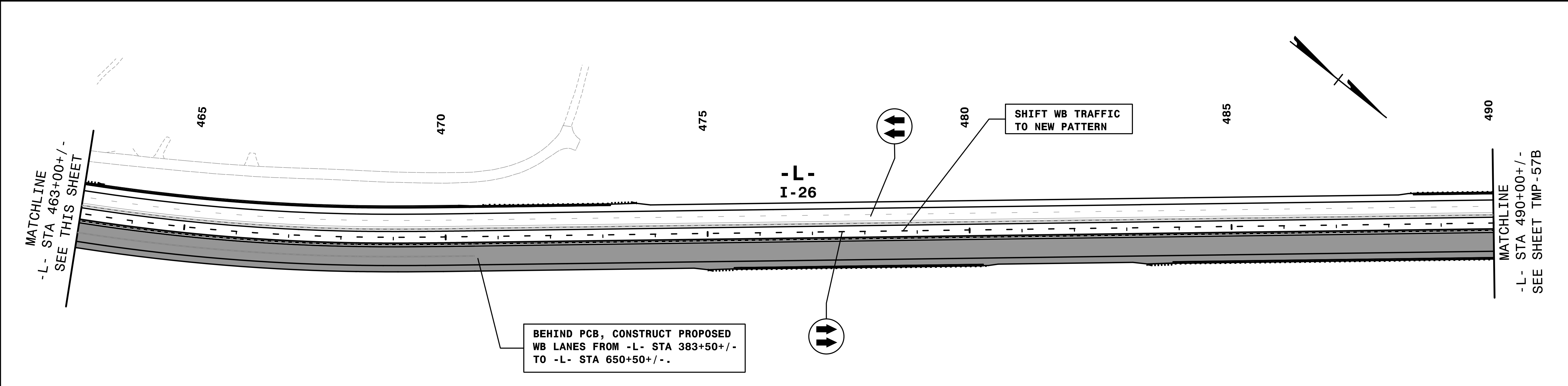
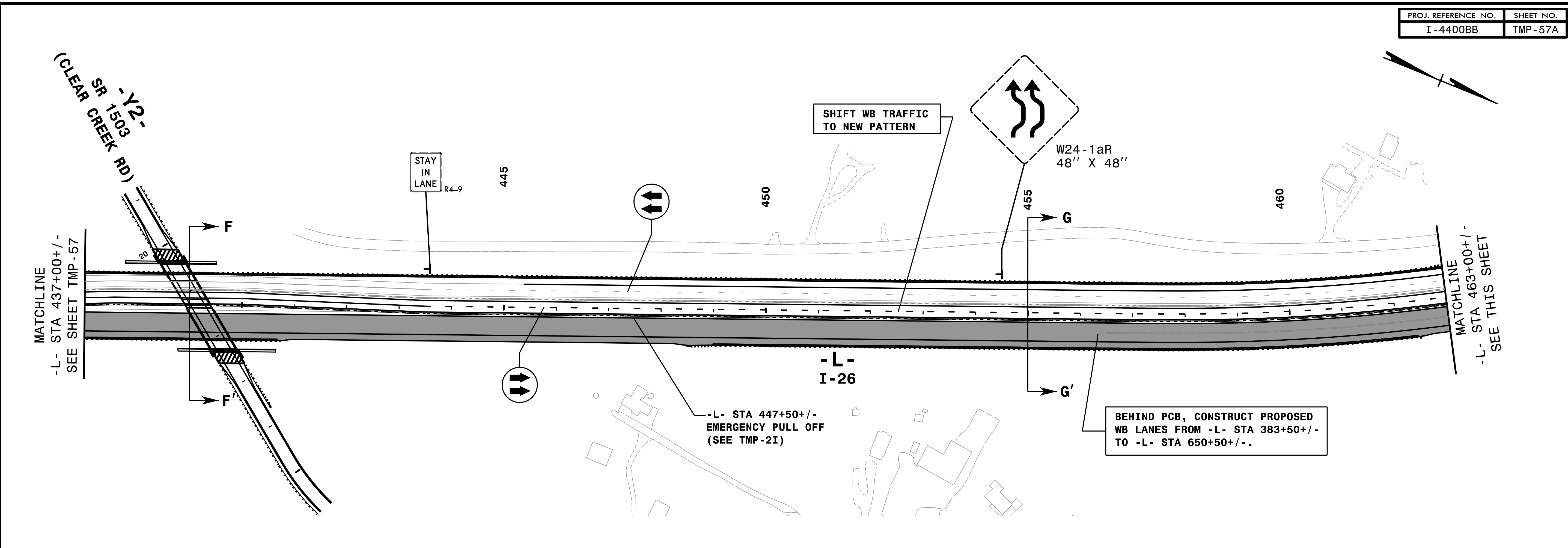

REFER TO SHEET TMP-58 FOR CUT SECTIONS.

1:05:39 PM  
\\T:\aff\Control\TCP\OV\_P4\_2.dgn  
9/3/2019

**HNTB**  
 HNTB NORTH CAROLINA, P.C.  
 343 E. Six Forks Road, Suite 200  
 Raleigh, North Carolina 27609  
 NC License No: C-1554

APPROVED: *Rhonda B. Early*  
 DATE: 9/3/2019

DocuSigned by:  
 F34CAFAC8BF48A

**PROFESSIONAL ENGINEER**  
 NORTH CAROLINA  
 SEAL  
 023521  
 RHONDA B. EARLY

**DOCUMENT NOT CONSIDERED FINAL  
 UNLESS ALL SIGNATURES COMPLETED**

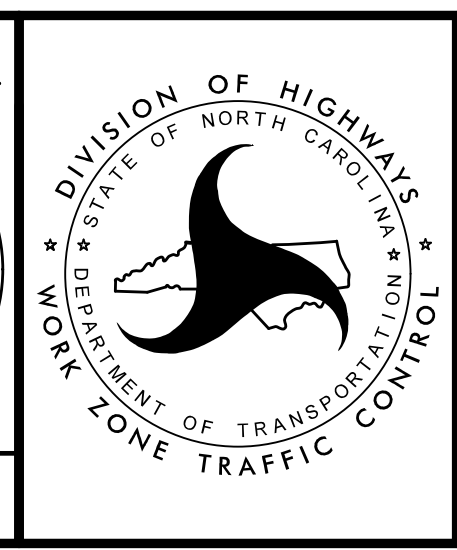

TRANSPORTATION  
 MANAGEMENT PLAN

PHASE IV  
 OVERVIEW

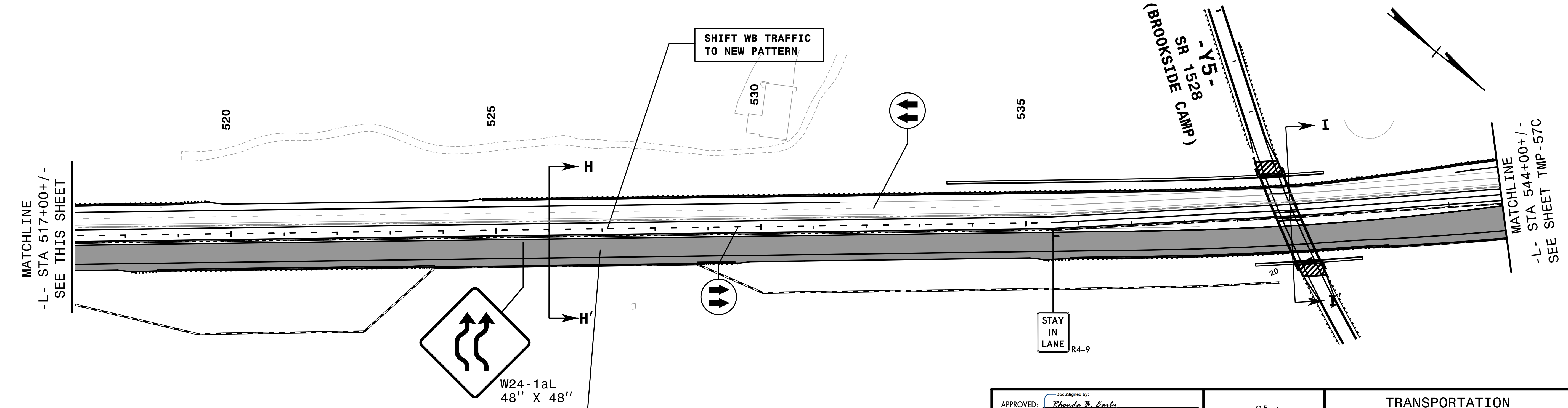
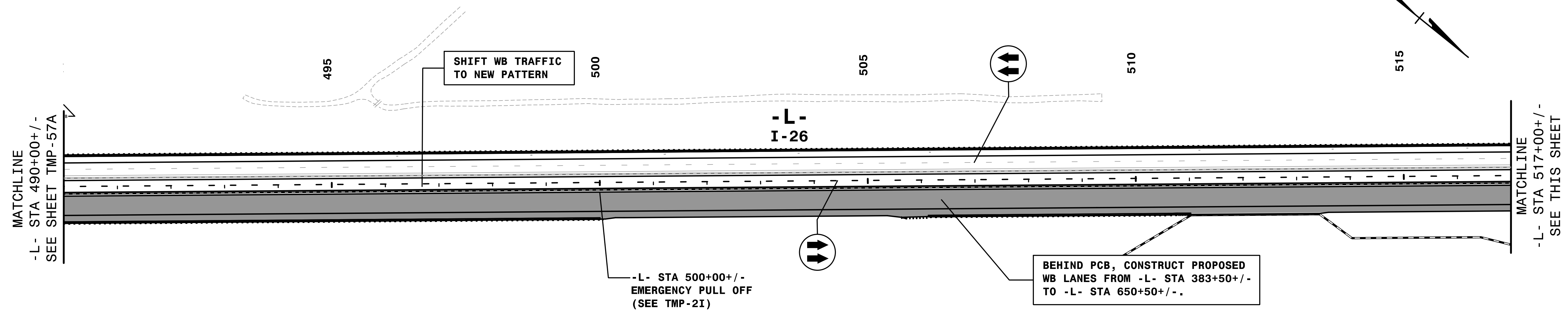

REFER TO SHEETS TMP-58A FOR CUT SECTIONS.

BEHIND PCB, CONSTRUCT PROPOSED WB LANES FROM -L- STA 383+50+/- TO -L- STA 650+50+/-.

W24-1aL  
48" X 48"

**HNTB**  
 HNTB NORTH CAROLINA, P.C.  
 343 E. SIX FORKS ROAD, SUITE 200  
 RALEIGH, NORTH CAROLINA 27609  
 NC LICENSE NO: C-1554

APPROVED: *Rhonda B. Early*  
 DATE: 9/3/2019

DocuSigned by:  
 Rhonda B. Early  
 F34CAFAC8BF48A

**PROFESSIONAL ENGINEER**  
 NORTH CAROLINA  
 SEAL  
 023521  
 RHONDA B. EARLY

**DOCUMENT NOT CONSIDERED FINAL UNLESS ALL SIGNATURES COMPLETED**



TRANSPORTATION MANAGEMENT PLAN

PHASE IV OVERVIEW

I:\05450 PM  
...TrafficControl\TCP\OV\_p4\_3.dgn  
9/3/2019

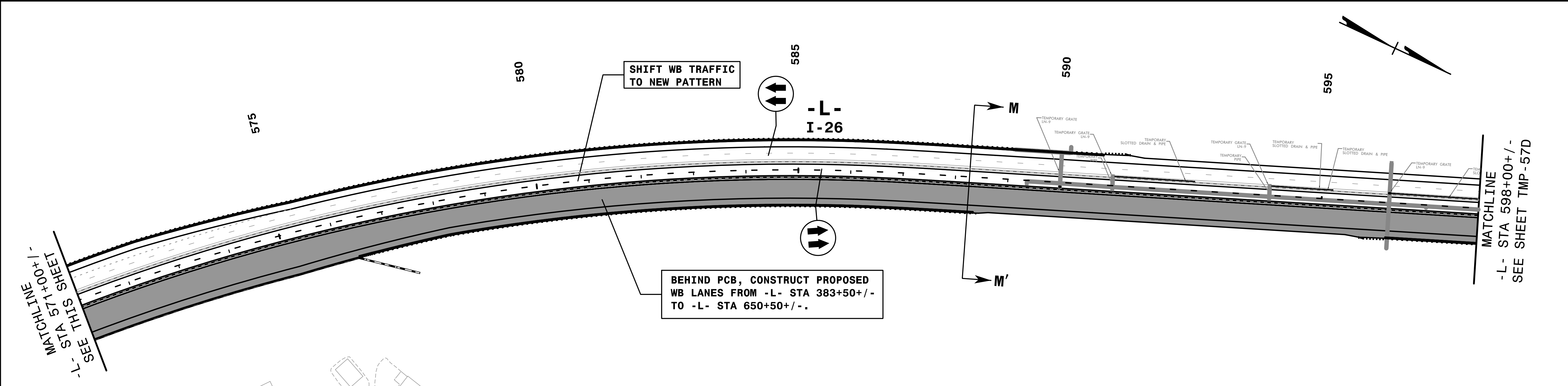
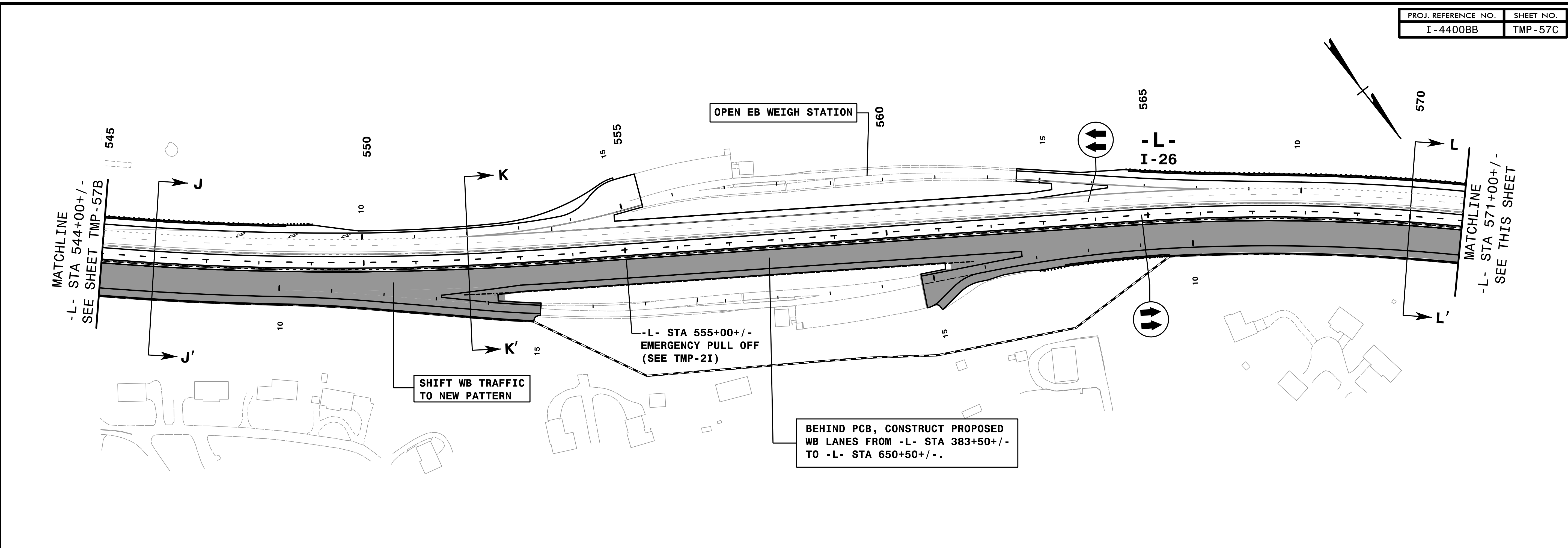

REFER TO SHEET TMP-58A FOR CUT SECTIONS.

I:\06402 PM TrafficControl\TCP\0V\_P4\_4.dgn 9/3/2019

**HNTB** HNTB NORTH CAROLINA, P.C.  
343 E. Six Forks Road, Suite 200  
Raleigh, North Carolina 27609  
NC License No: C-1554

APPROVED: *Rhonda B. Early*  
DATE: 9/3/2019

DocuSigned by:  
F34C2F5AC8BF48A

**NORTH CAROLINA**  
PROFESSIONAL  
SEAL  
023521  
**ENGINEER**  
**RHONDA B. EARLY**

**DOCUMENT NOT CONSIDERED FINAL  
UNLESS ALL SIGNATURES COMPLETED**

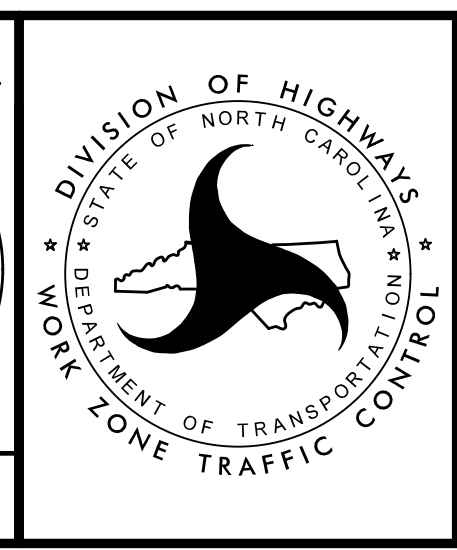

TRANSPORTATION  
MANAGEMENT PLAN

PHASE IV  
OVERVIEW

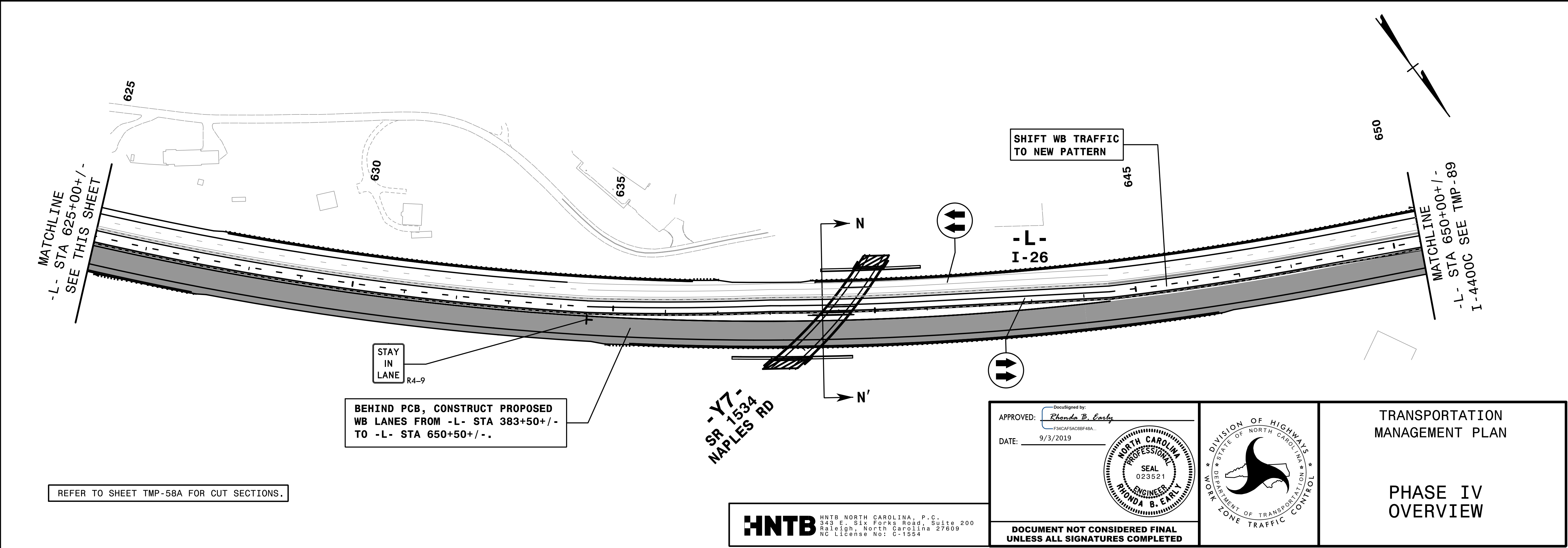
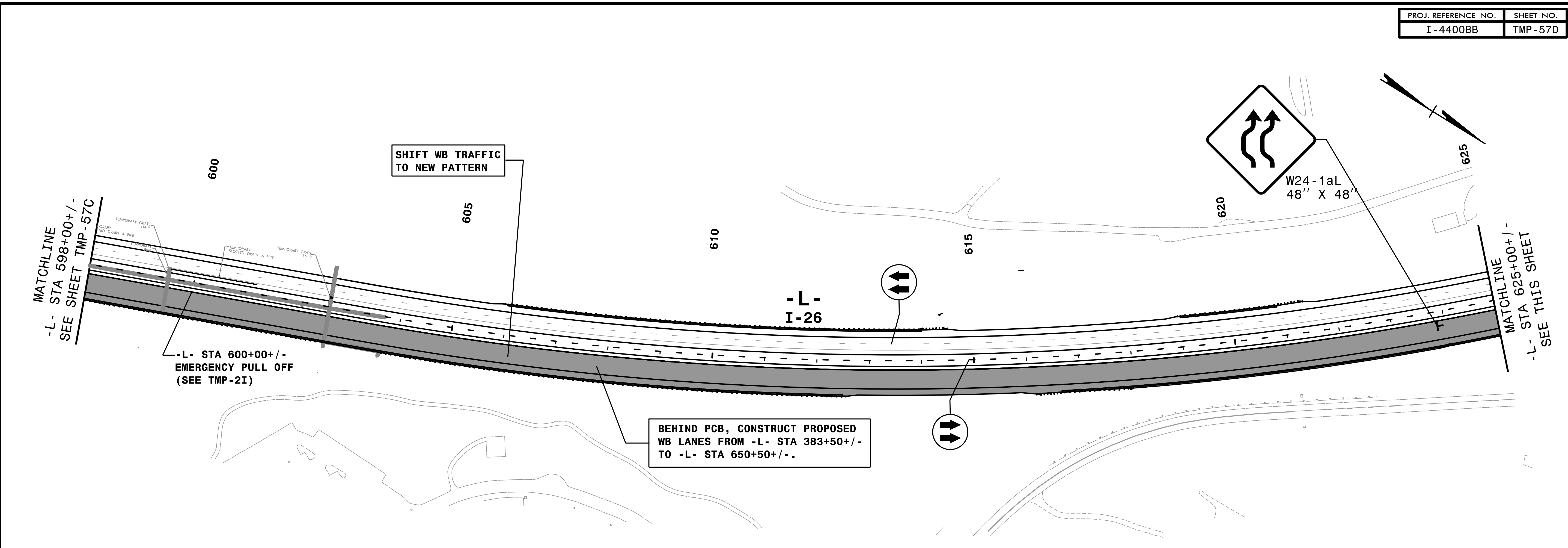

REFER TO SHEET TMP-58A FOR CUT SECTIONS.

I:\0614 PM  
...T\off\Control\TCP\OV\_P4\_5.dgn  
9/3/2019

**HNTB**  
 HNTB NORTH CAROLINA, P.C.  
 343 E. SIX FORKS ROAD, SUITE 200  
 RALEIGH, NORTH CAROLINA 27609  
 NC LICENSE NO: C-1554

APPROVED: *Rhonda B. Early*  
 DATE: 9/3/2019

DocuSigned by:  
 F34CAFAC8BF48A...

**PROFESSIONAL ENGINEER**  
 NORTH CAROLINA  
 SEAL  
 023521  
 RHONDA B. EARLY



TRANSPORTATION  
 MANAGEMENT PLAN

PHASE IV  
 OVERVIEW

DOCUMENT NOT CONSIDERED FINAL  
UNLESS ALL SIGNATURES COMPLETED