

**This electronic collection of documents is provided
for the convenience of the user
and is Not a Certified Document –**

**The documents contained herein were originally issued
and sealed by the individuals whose names and license
numbers appear on each page, on the dates appearing
with their signature on that page.**

**This file or an individual page
shall not be considered a certified document.**

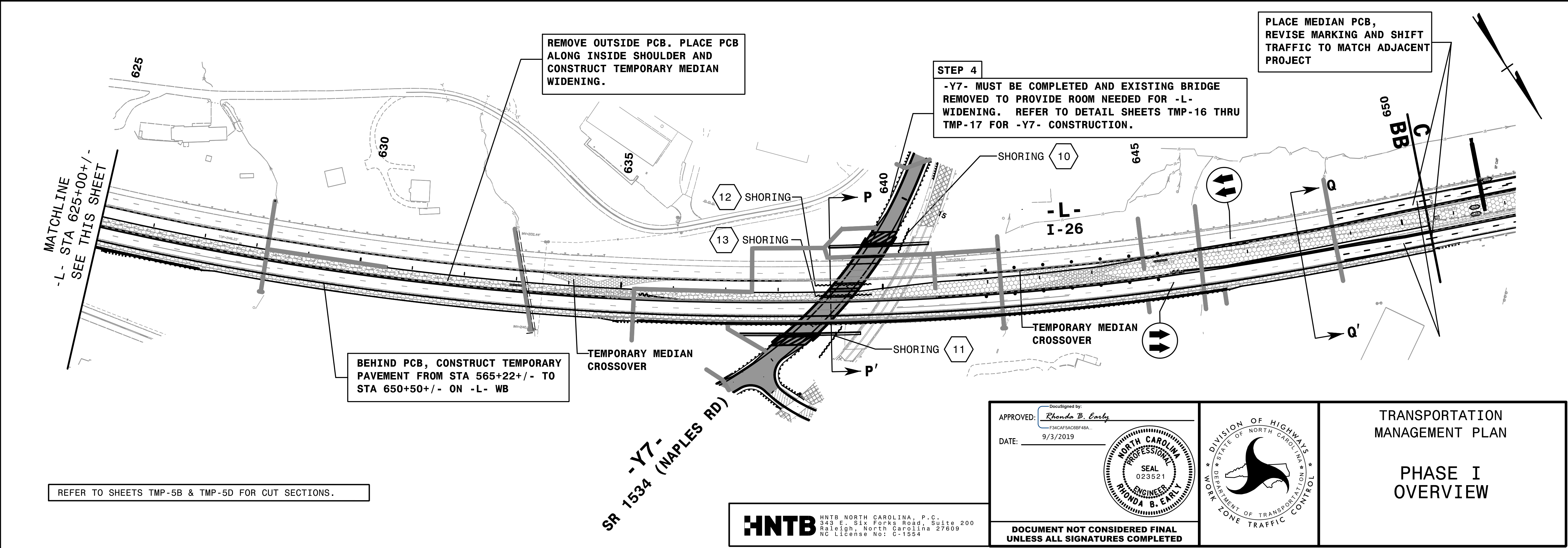
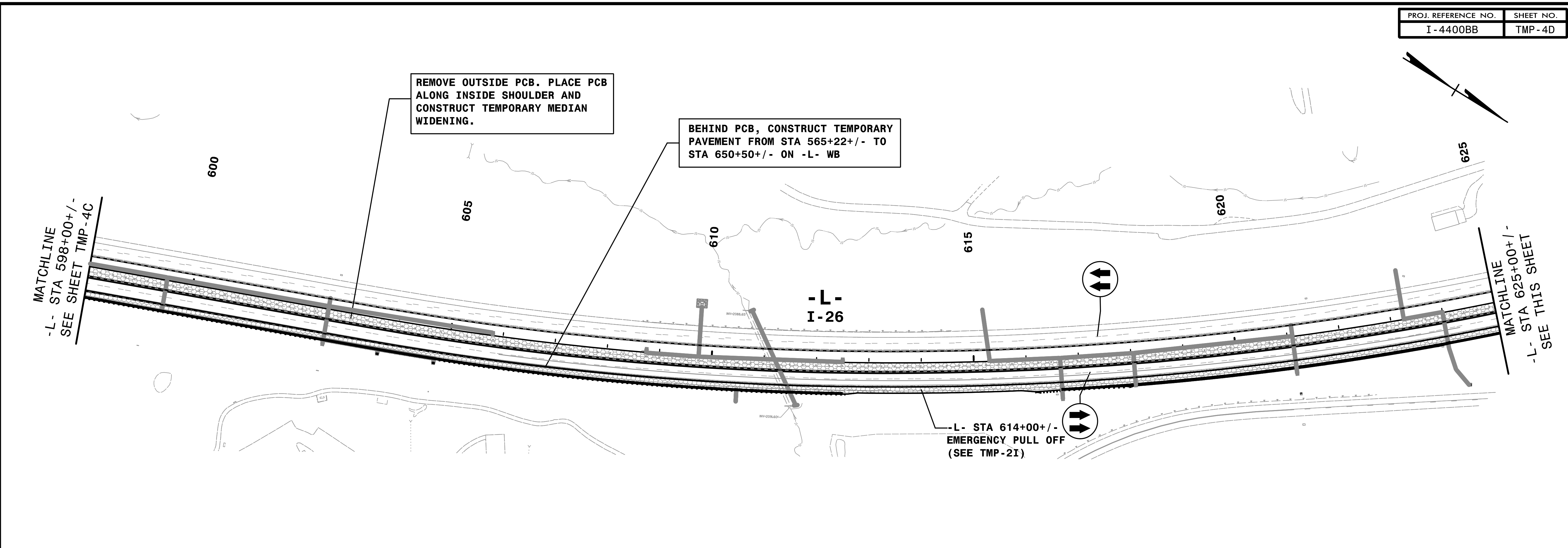

12:36:59 PM
\\p1at-ficcontrol\tcp\ov_pl5.dgn
9/3/2019

REFER TO SHEETS TMP-5B & TMP-5D FOR CUT SECTIONS.

SR 1534 (-Y7- (NAPLES RD))

HNTB
HNTB NORTH CAROLINA, P.C.
343 E. Six Forks Road, Suite 200
Raleigh, North Carolina 27609
NC License No: C-1554

APPROVED: *Rhonda B. Early*
DATE: 9/3/2019

DocuSigned by:
Rhonda B. Early
F34CAF5AC8BF48A...

NORTH CAROLINA
PROFESSIONAL
ENGINEERS
SEAL
023521
RHONDA B. EARLY

**DOCUMENT NOT CONSIDERED FINAL
UNLESS ALL SIGNATURES COMPLETED**

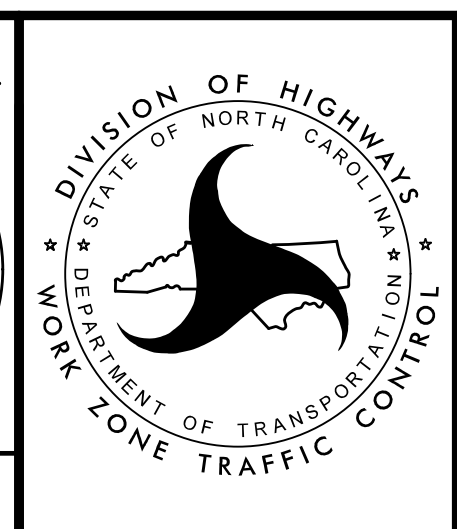

TRANSPORTATION
MANAGEMENT PLAN

PHASE I
OVERVIEW

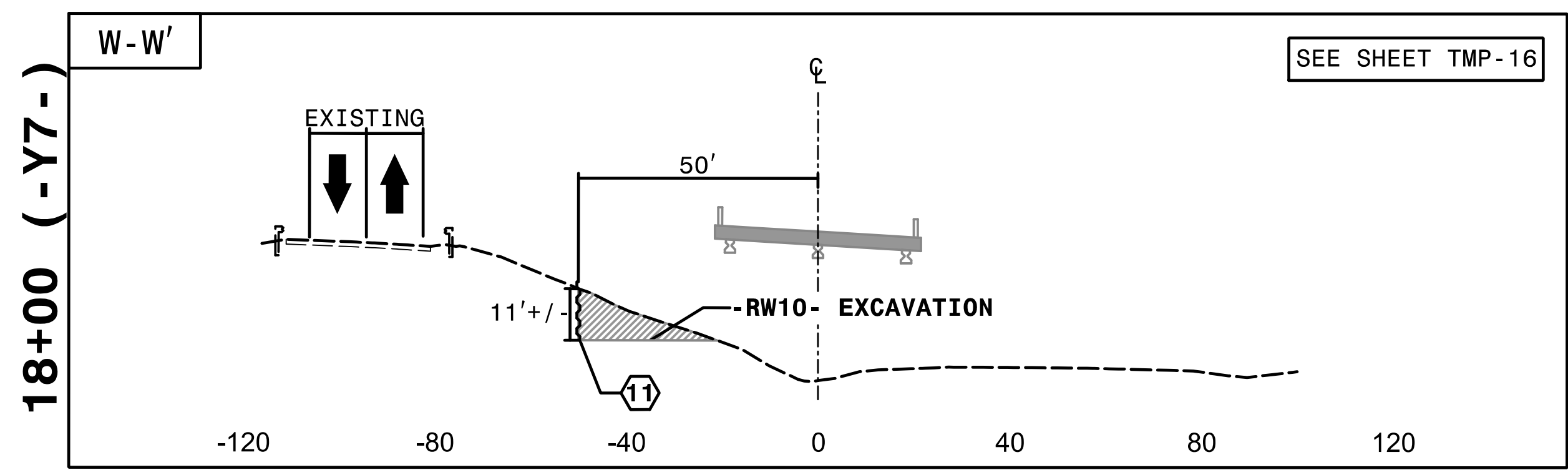
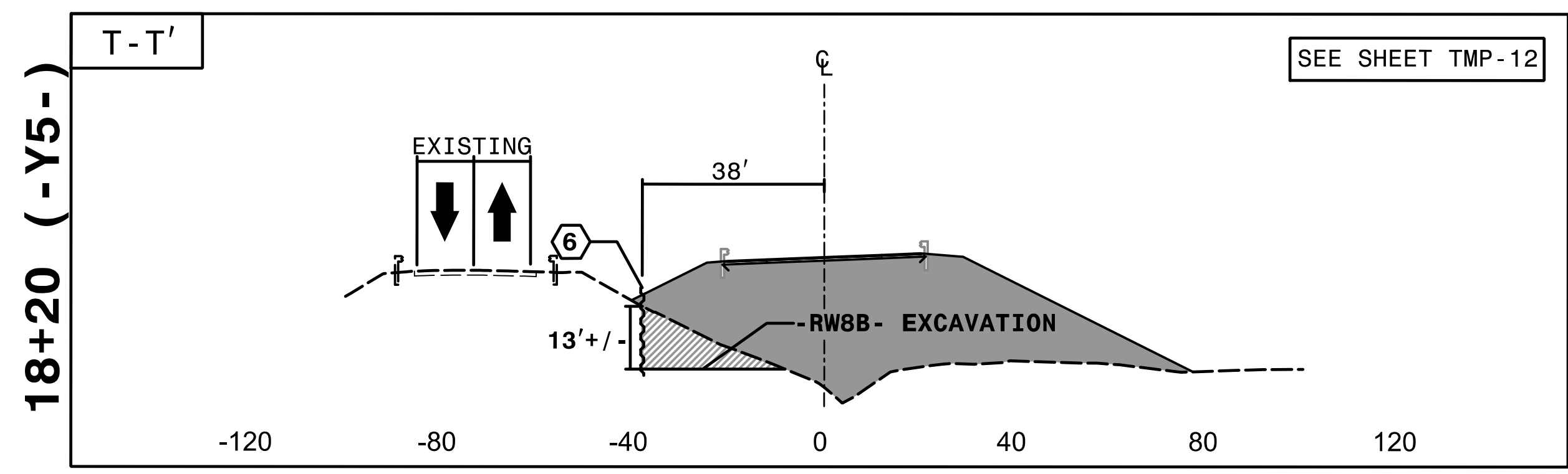
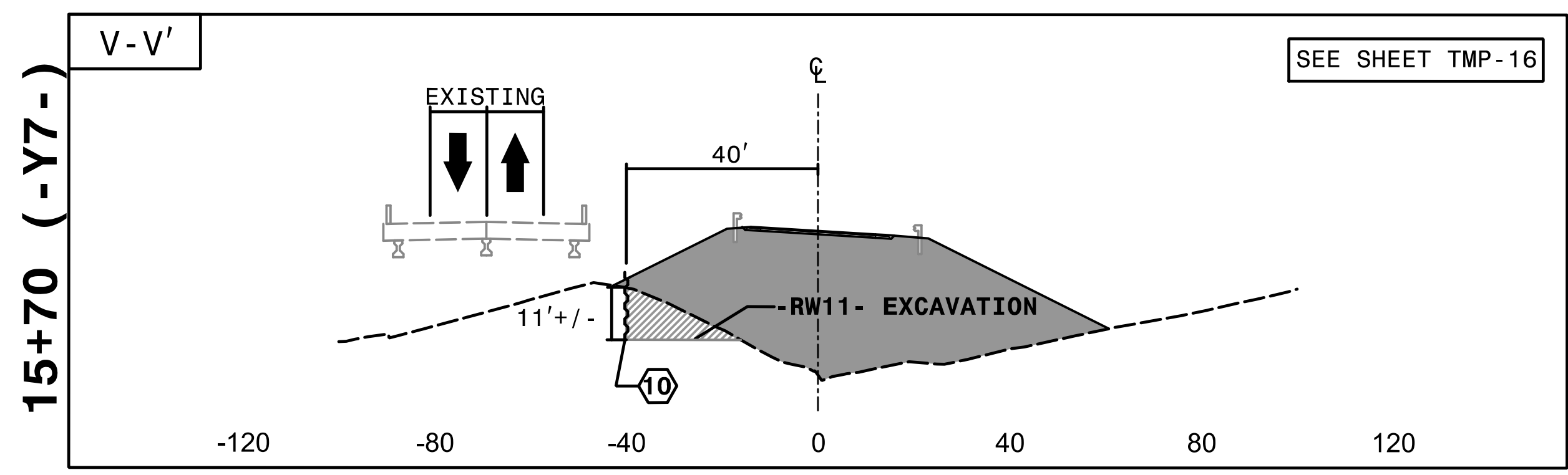
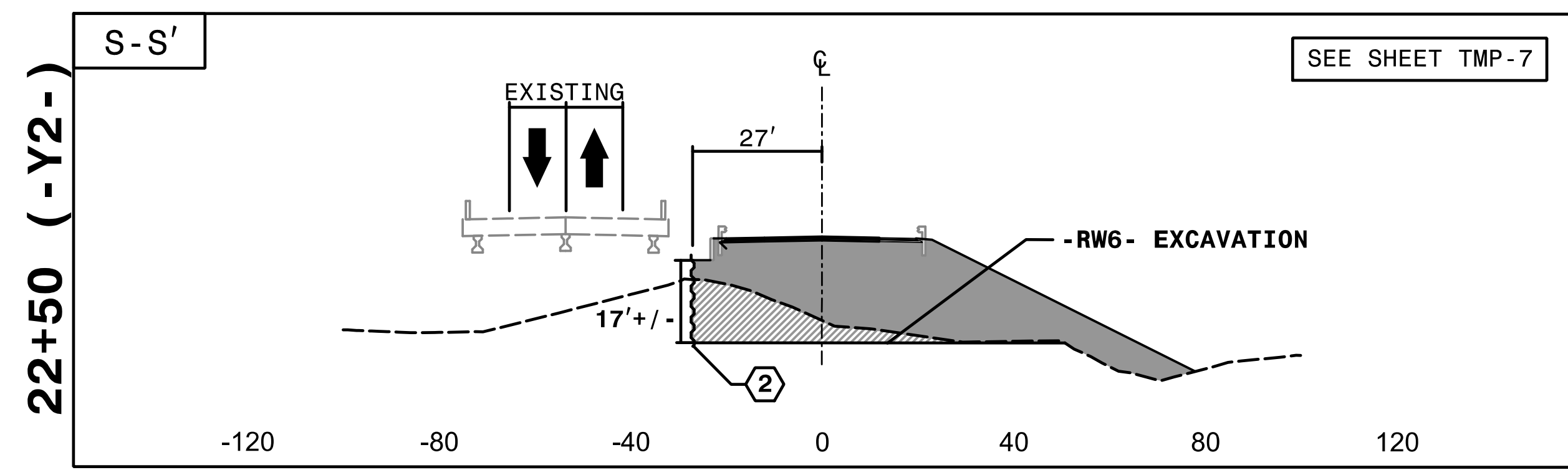
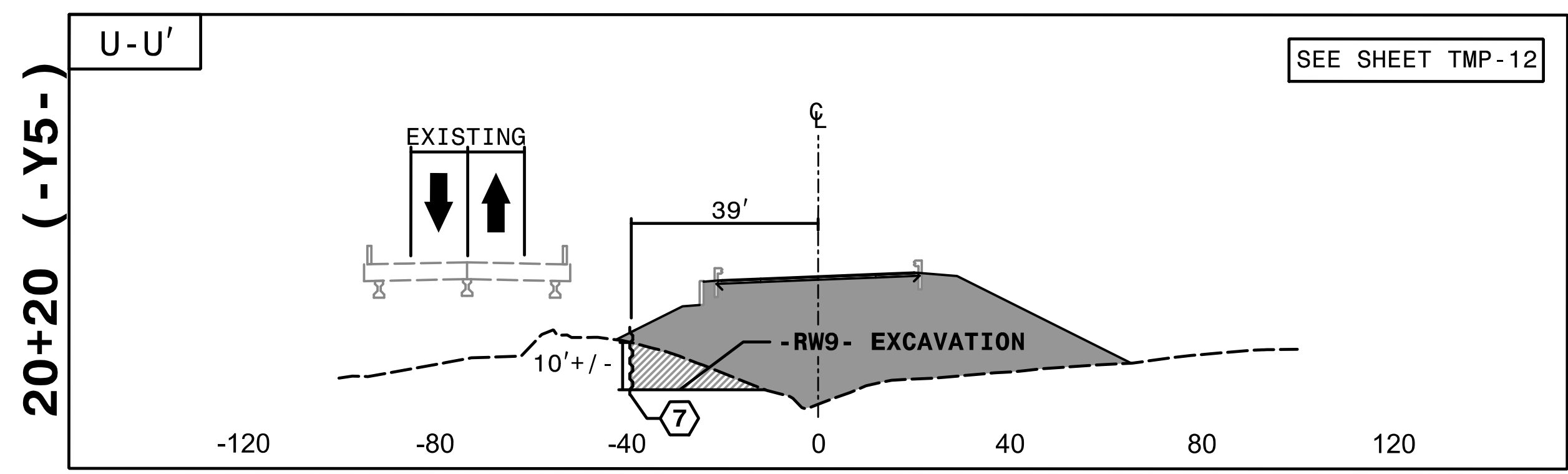
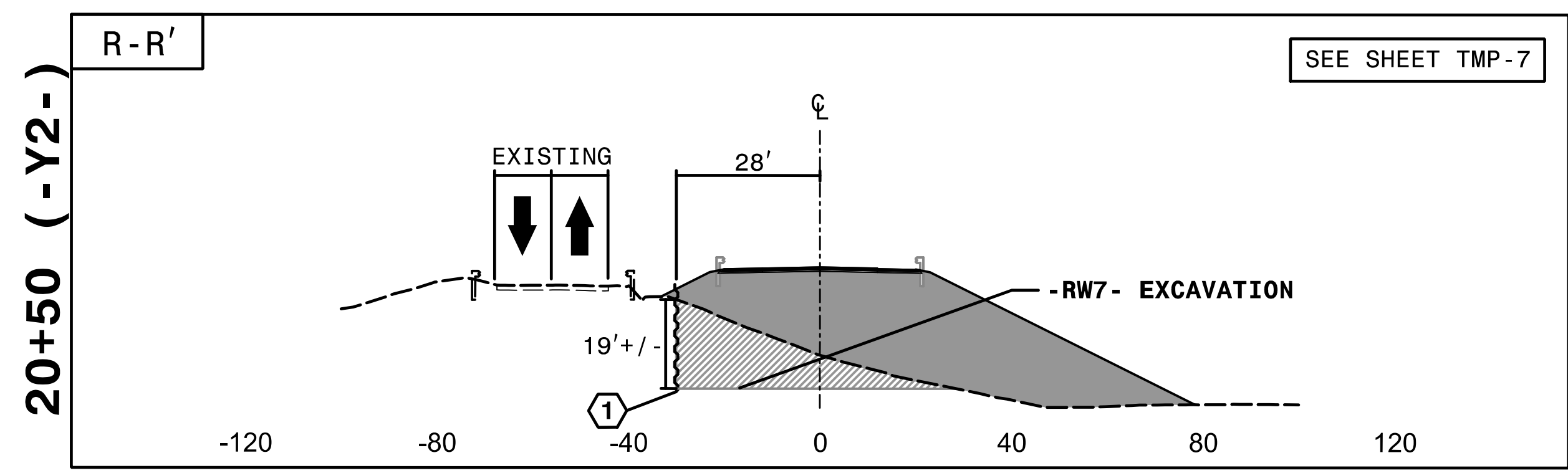

12:37:41 PM
I:\CPN\4400BB-TC-PICUTS.dgn
9/3/2019

HNTB
HNTB NORTH CAROLINA, P.C.
349 E. Six Forks Road, Suite 200
Raleigh, North Carolina 27609
NC License No: C-1554

APPROVED: *Rhonda B. Early*
F34CAF5ACBF4BA
DATE: 9/3/2019

NORTH CAROLINA
PROFESSIONAL
SEAL
023521
ENGINEER
RHONDA B. EARLY

**DOCUMENT NOT CONSIDERED FINAL
UNLESS ALL SIGNATURES COMPLETED**

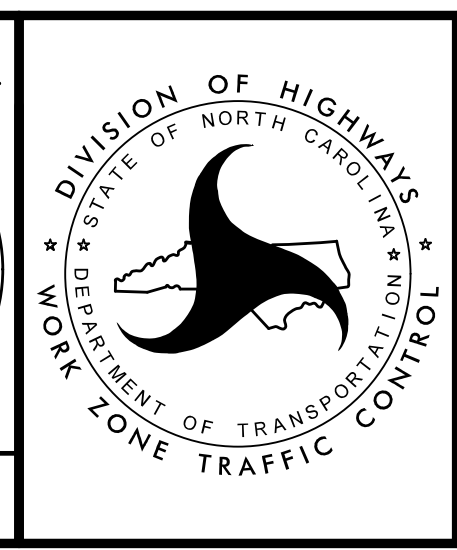

TRANSPORTATION
MANAGEMENT PLAN

PHASE I
CUT SECTIONS

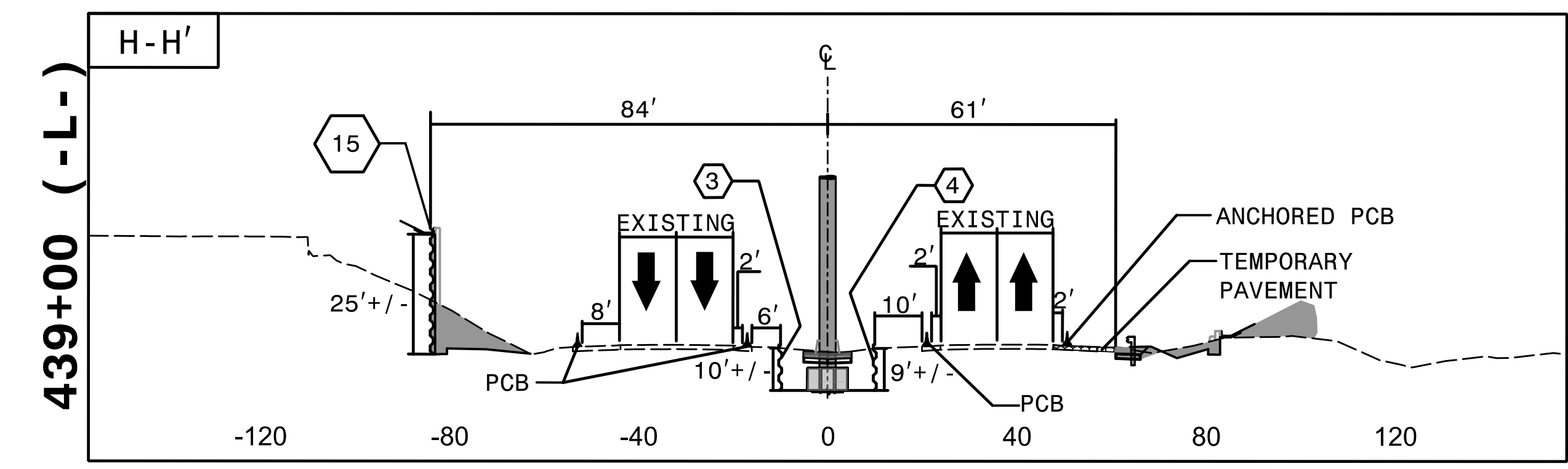
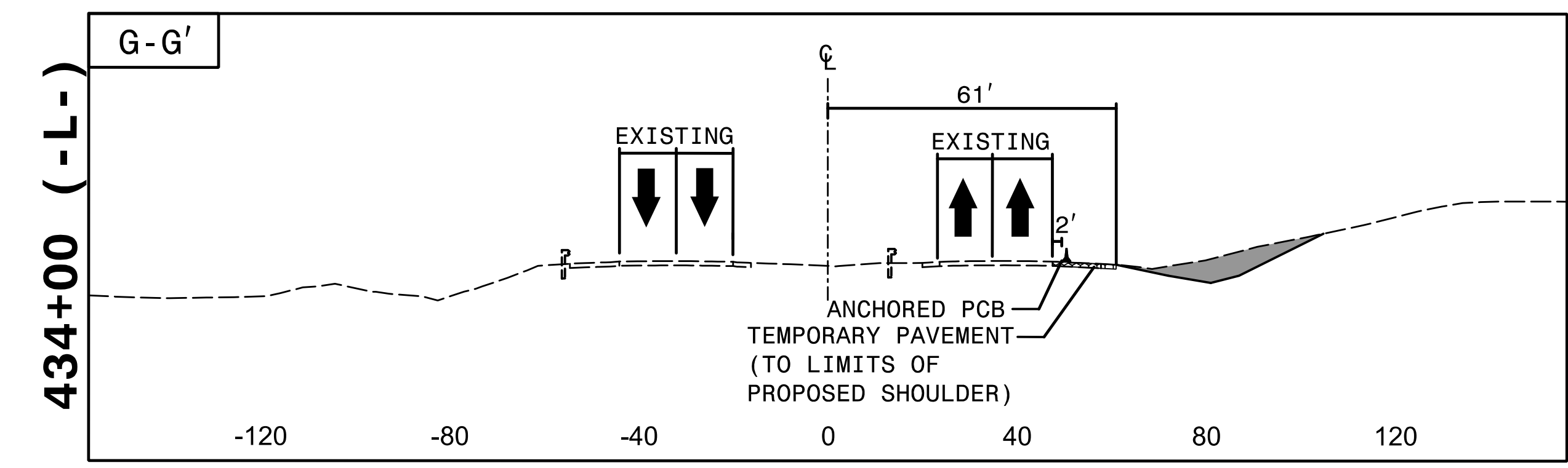
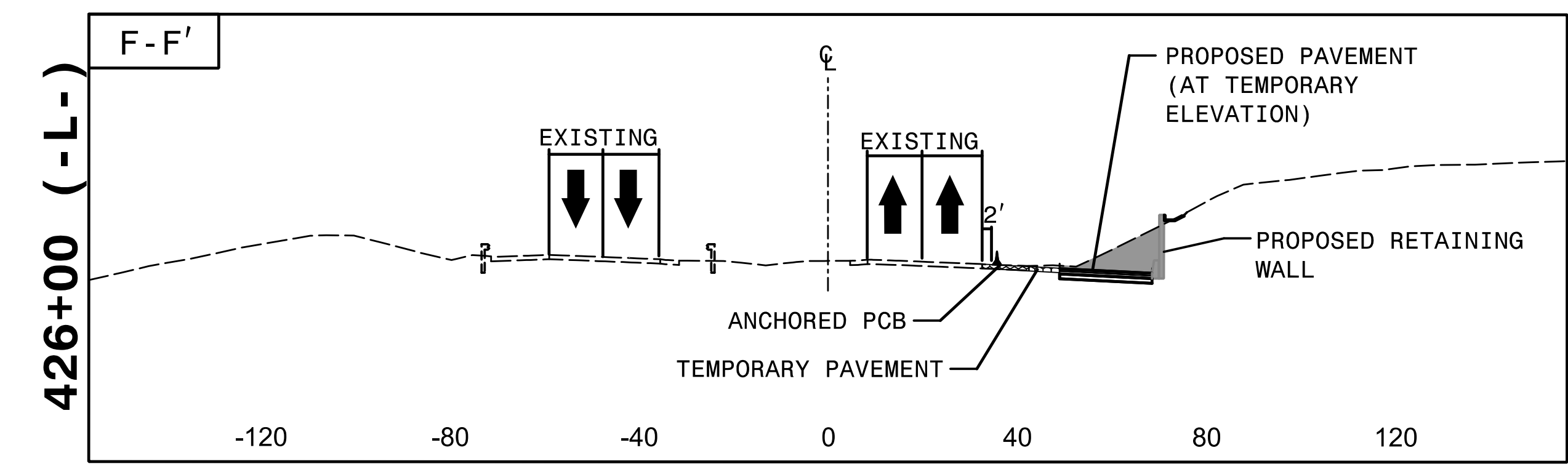
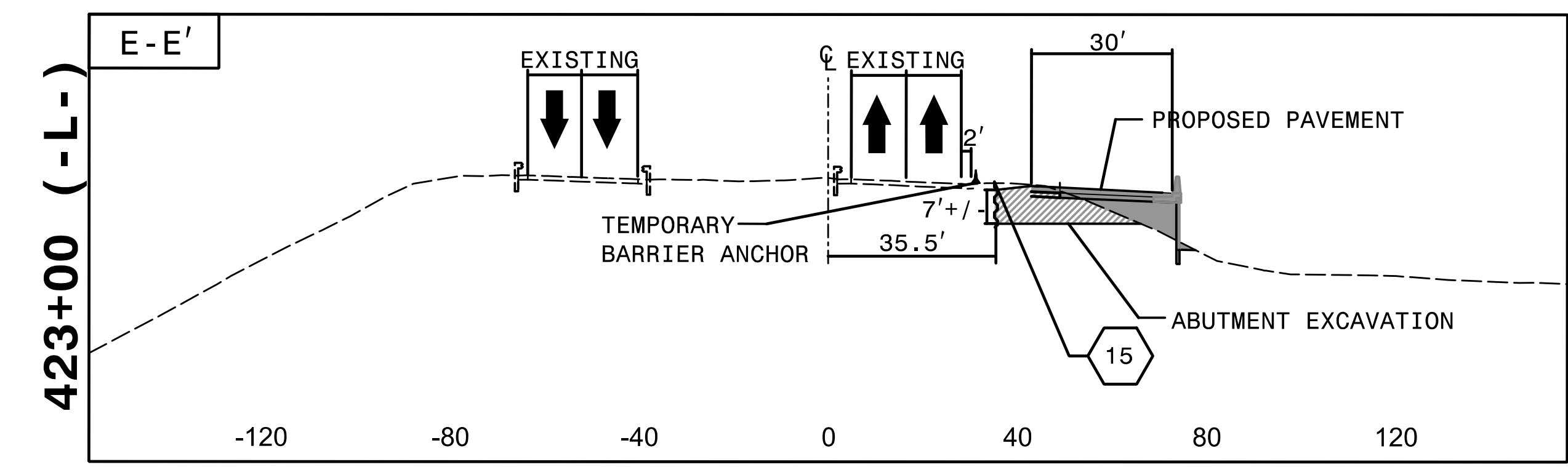
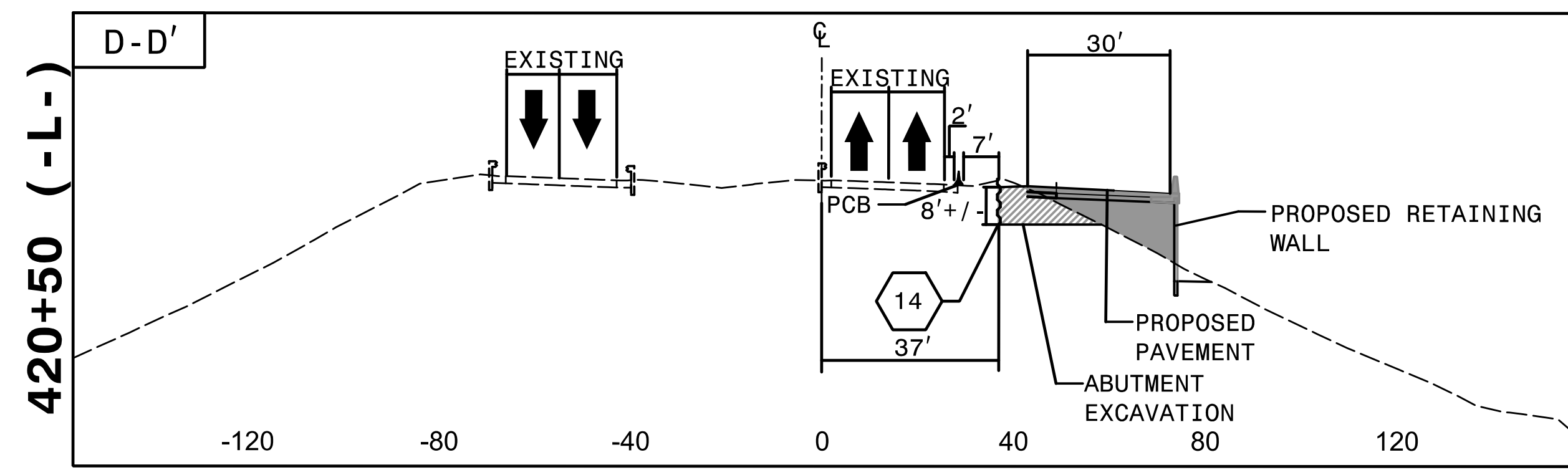
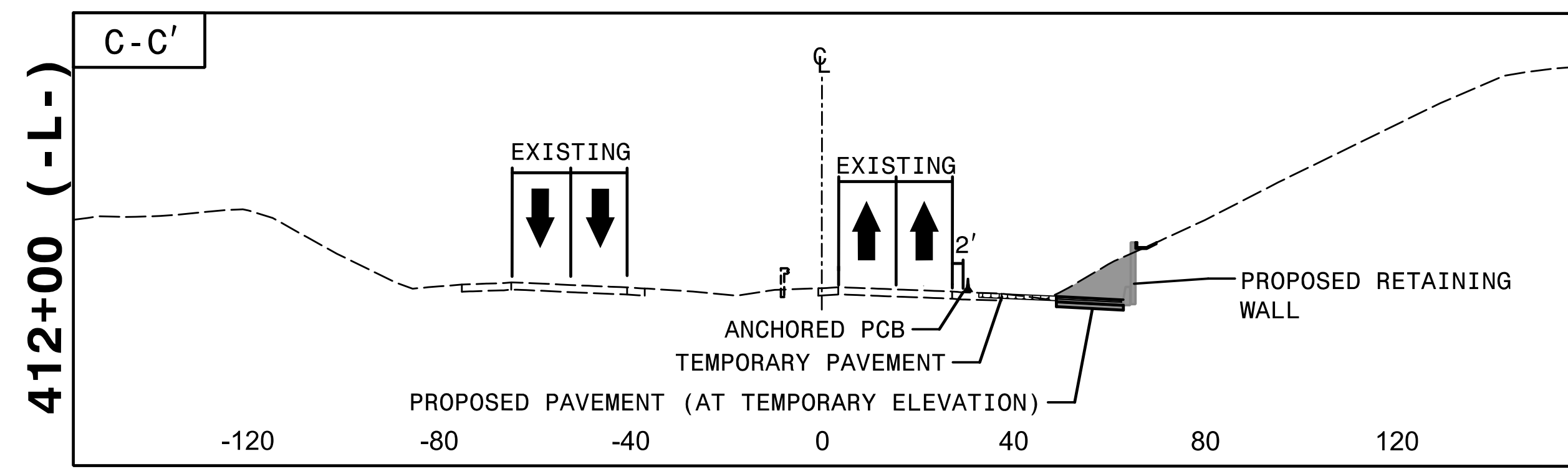
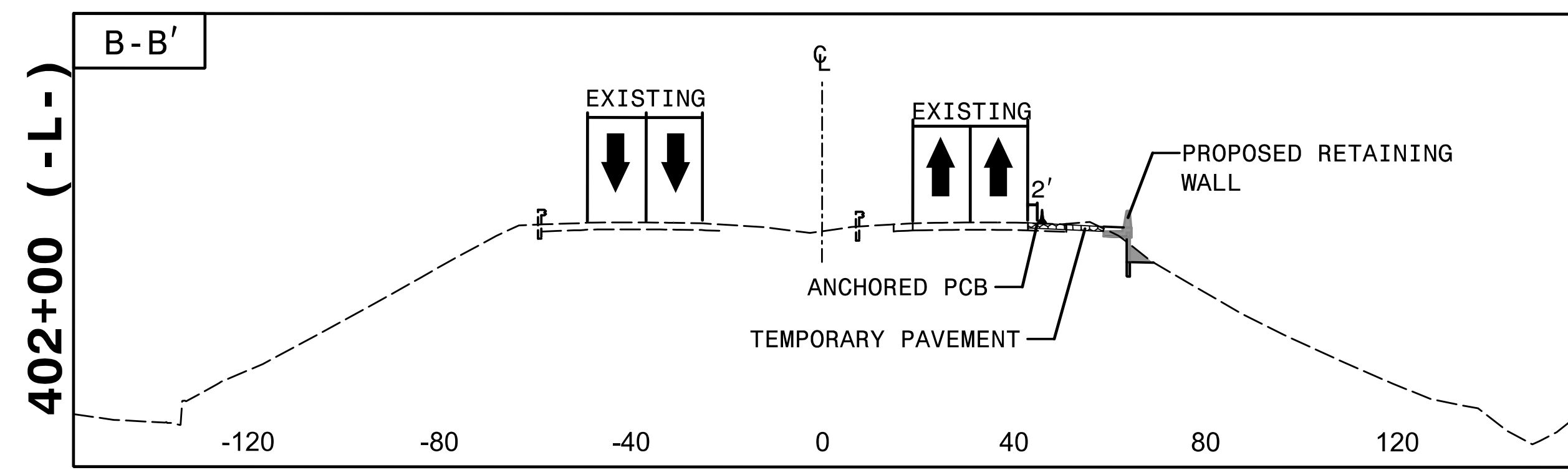
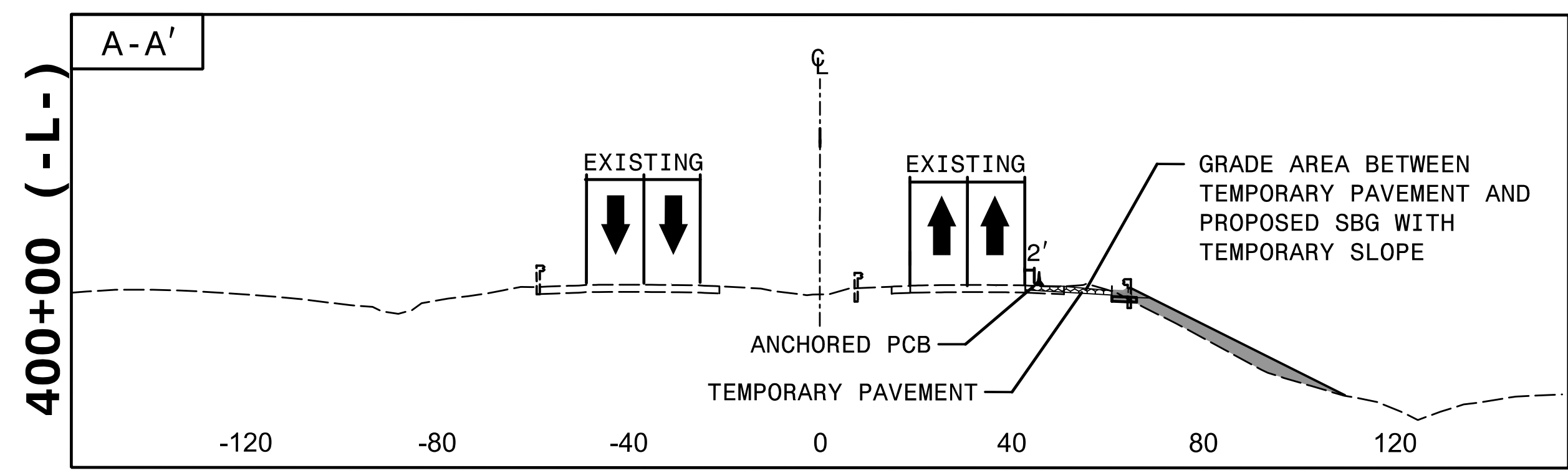

12:37:51 PM
I:\CPN\4400BB_fc_PICUTS.dgn
9/3/2019



APPROVED: *Rhonda B. Early*
DATE: 9/3/2019

DocuSigned by:
Rhonda B. Early
F34CAFAC6BF48A

NORTH CAROLINA
PROFESSIONAL
ENGINEERS
SEAL
023521
RHONDA B. EARLY

**DOCUMENT NOT CONSIDERED FINAL
UNLESS ALL SIGNATURES COMPLETED**

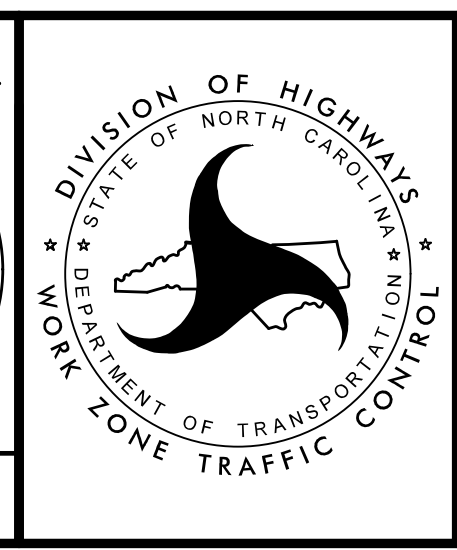

TRANSPORTATION
MANAGEMENT PLAN

PHASE I
CUT SECTIONS
STEP 5.1 THRU 5.3

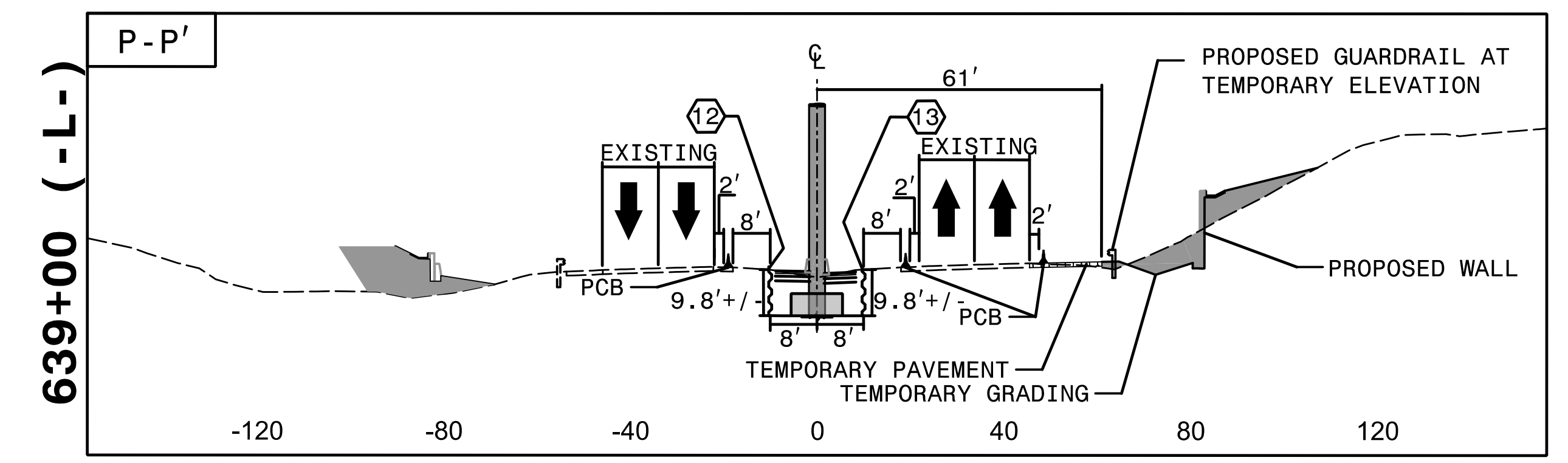
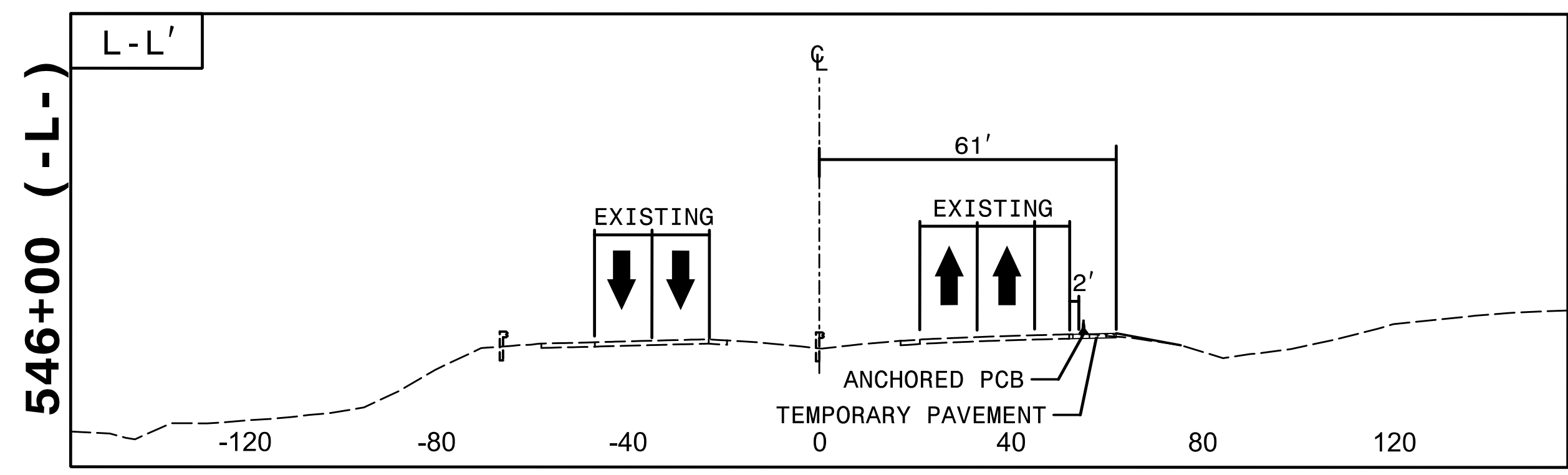
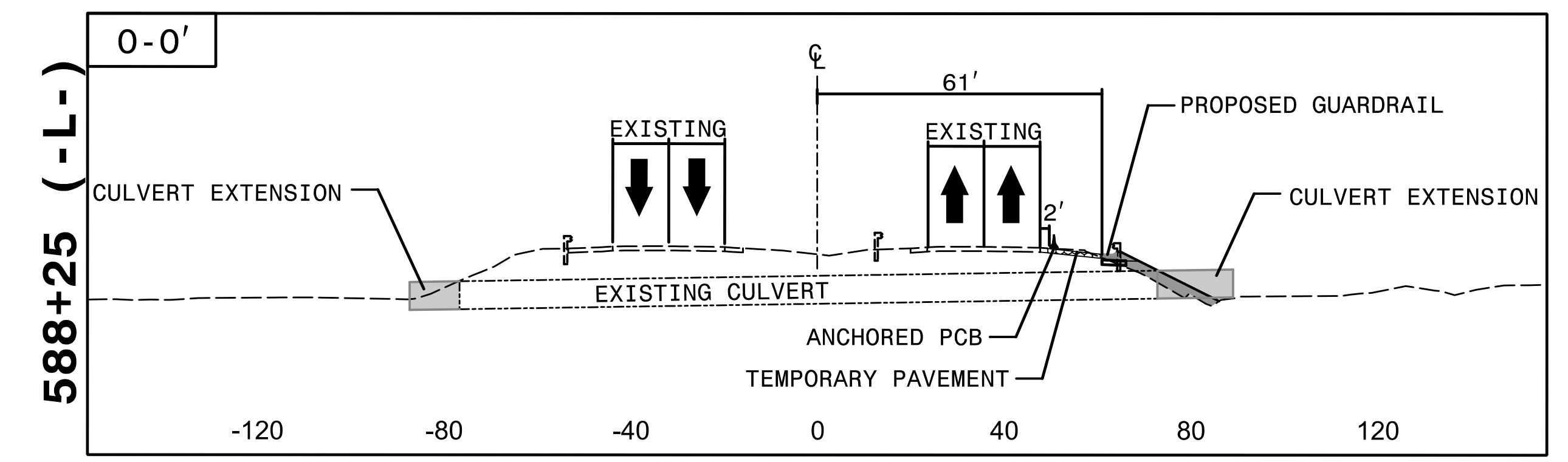
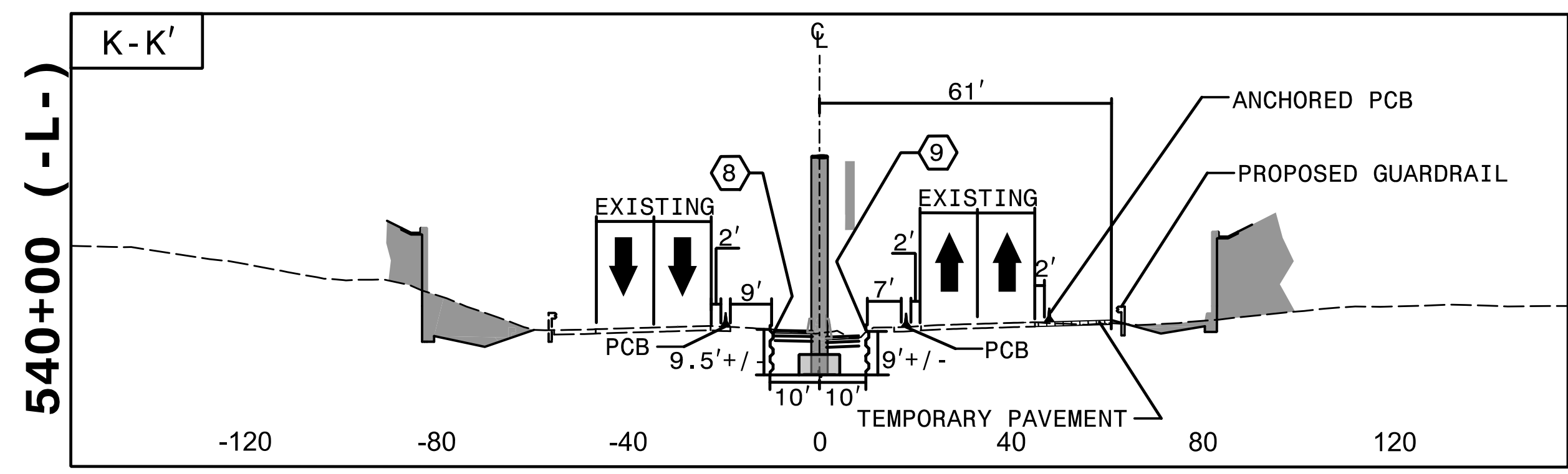
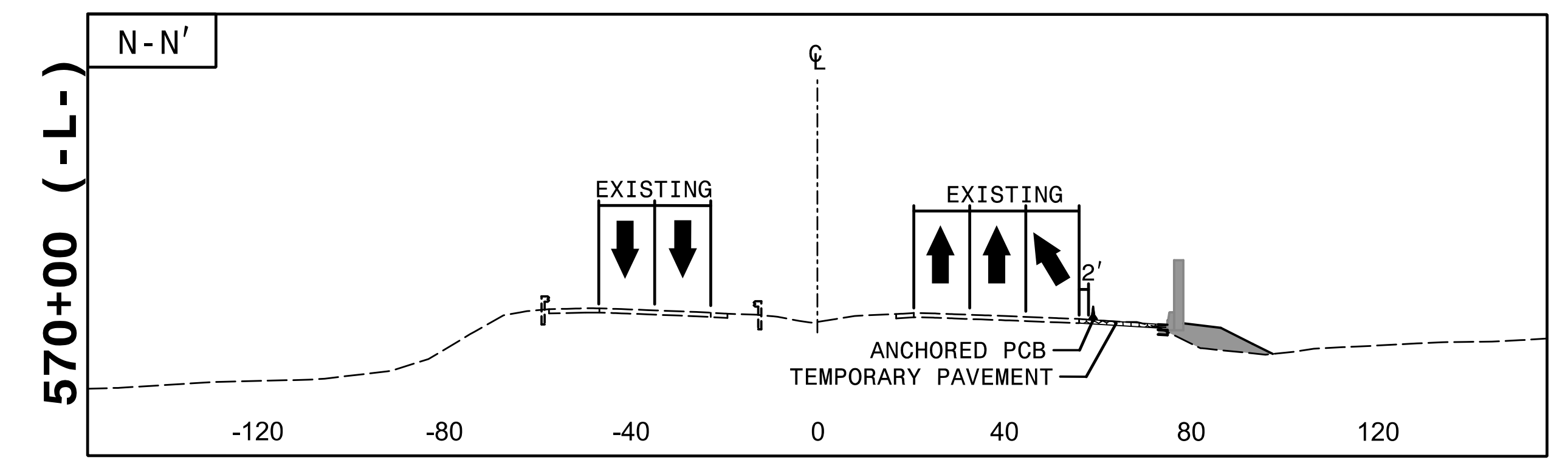
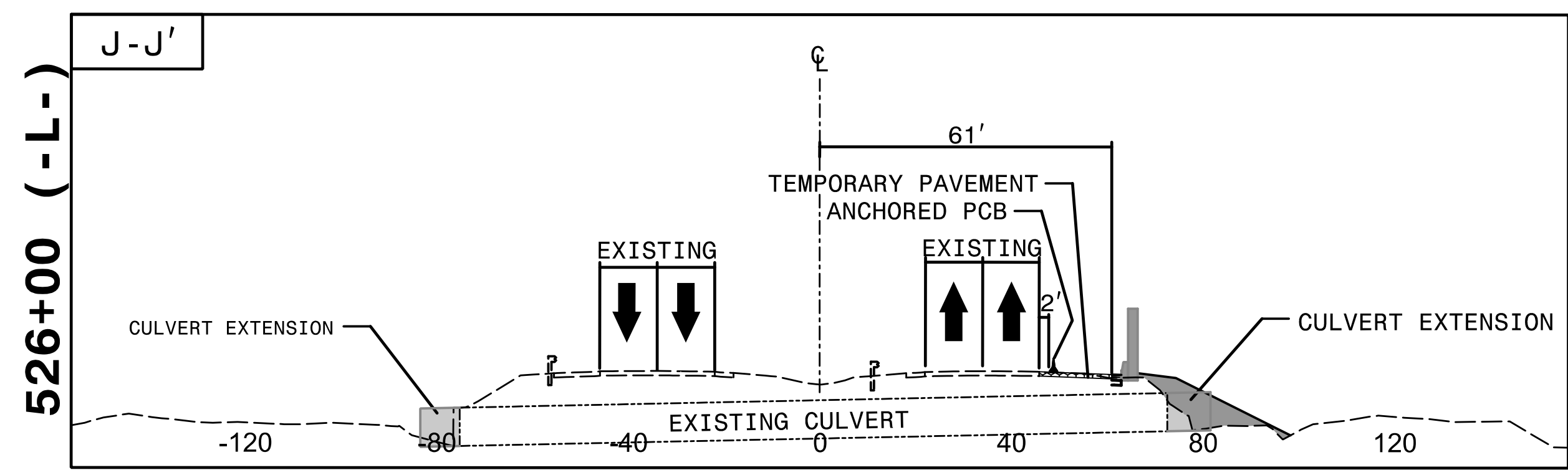
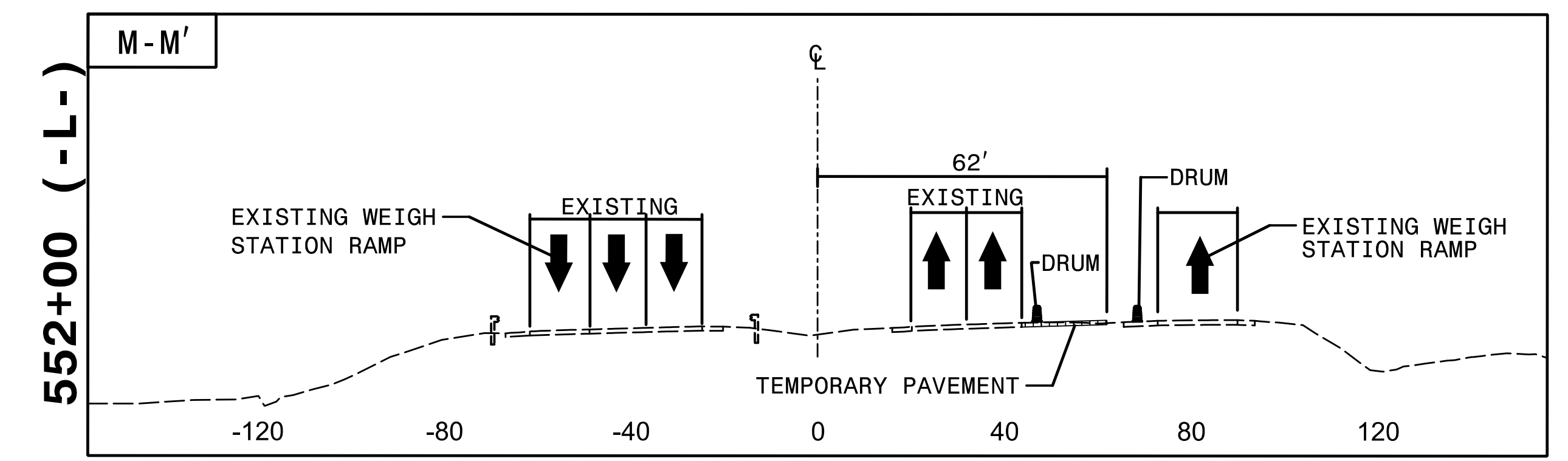
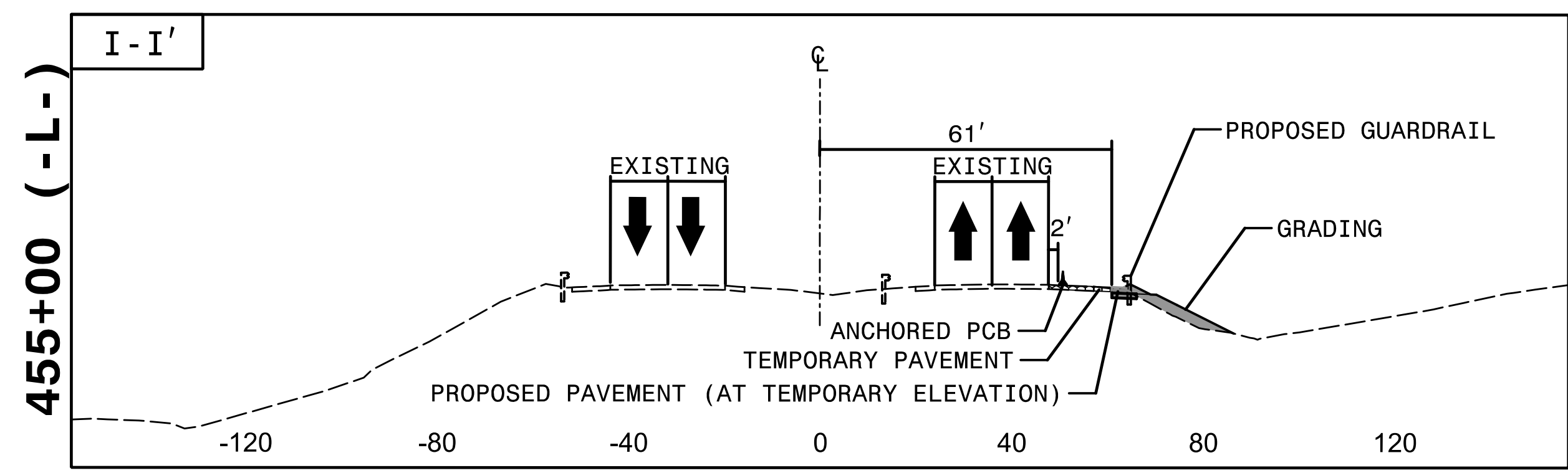

12:38:02 PM
I:\CP\4400BB_Tc_PICUTS.dgn
9/3/2019



APPROVED: *Rhonda B. Early*
343 E. Six Forks Road, Suite 200
 Raleigh, North Carolina 27609
 NC License No: C-1554

DATE: 9/3/2019

SEAL
 NORTH CAROLINA
 PROFESSIONAL ENGINEER
 RHONDA B. EARLY
 023521

DOCUMENT NOT CONSIDERED FINAL
 UNLESS ALL SIGNATURES COMPLETED

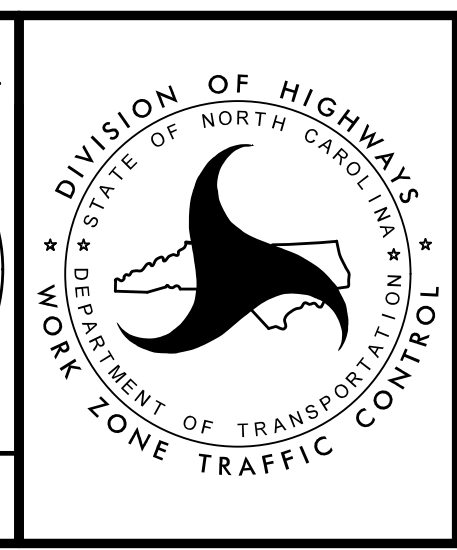

TRANSPORTATION
 MANAGEMENT PLAN

PHASE I
 CUT SECTIONS
 STEP 5.1 THRU 5.3

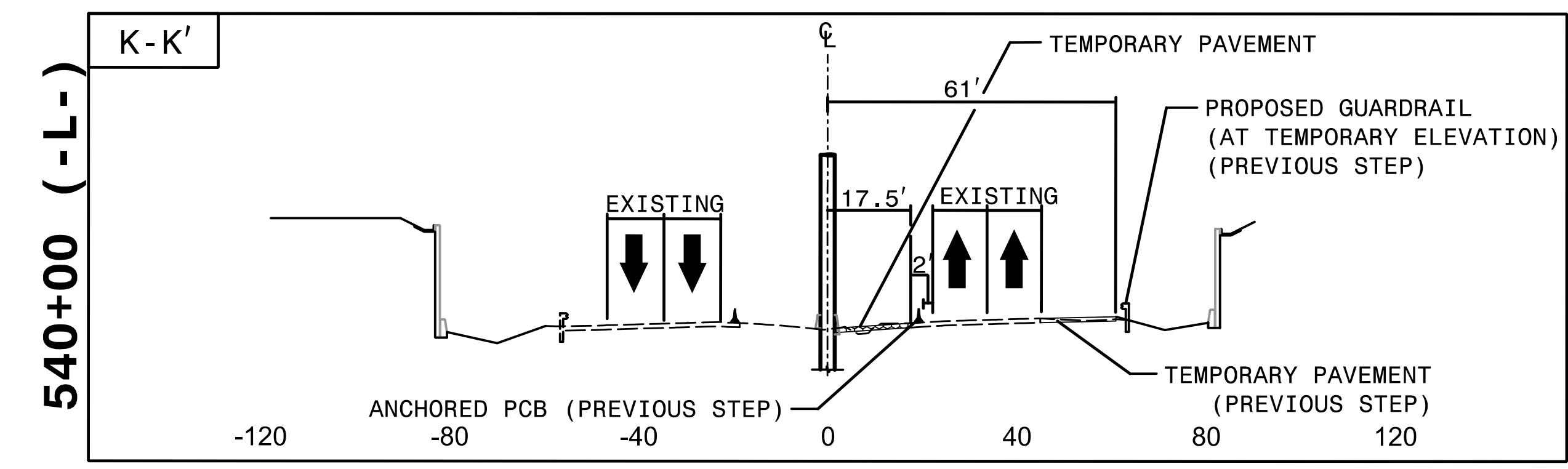
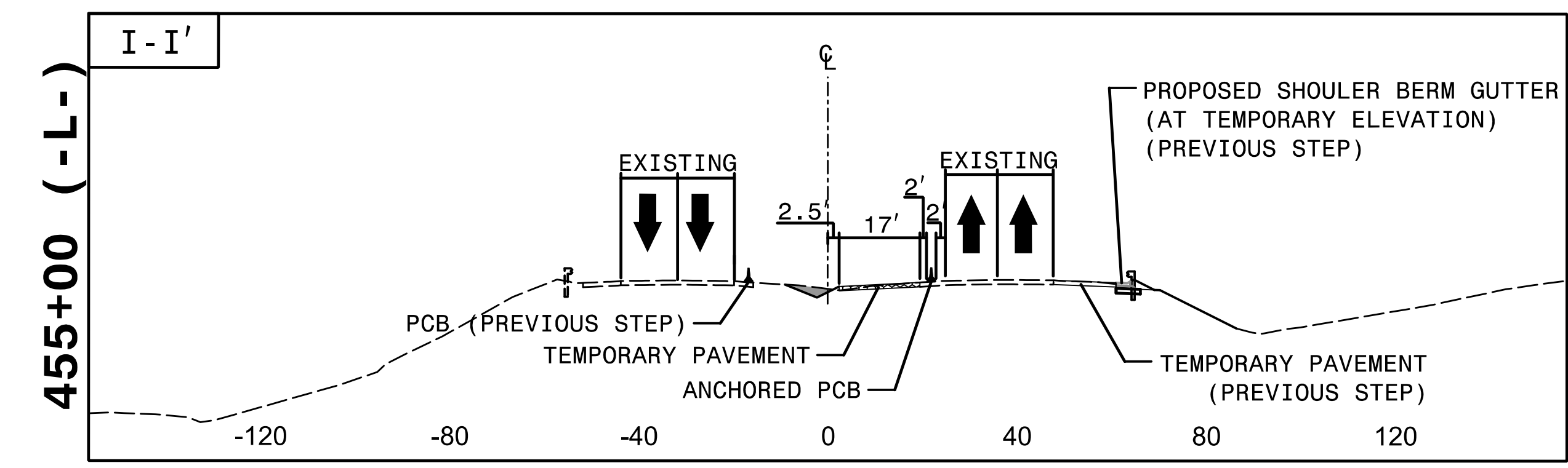
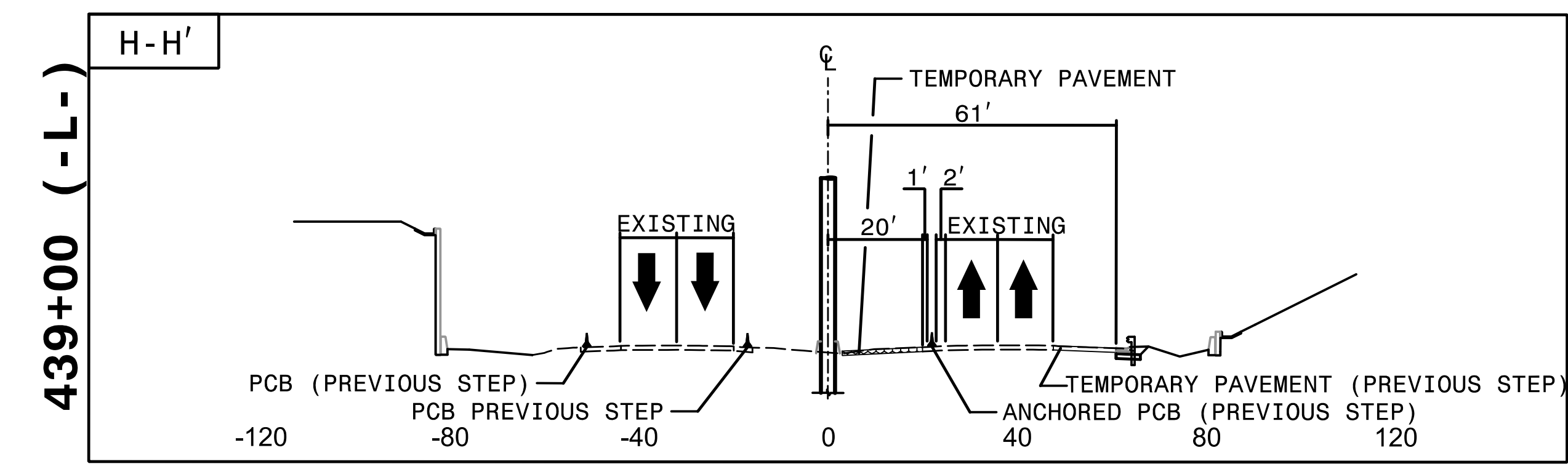
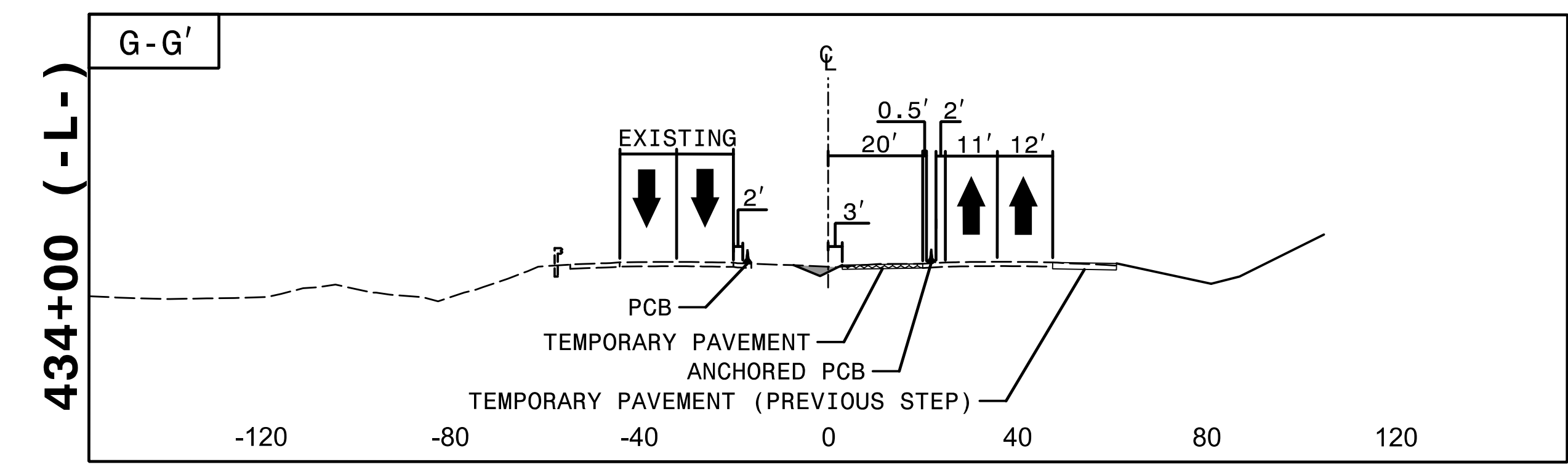
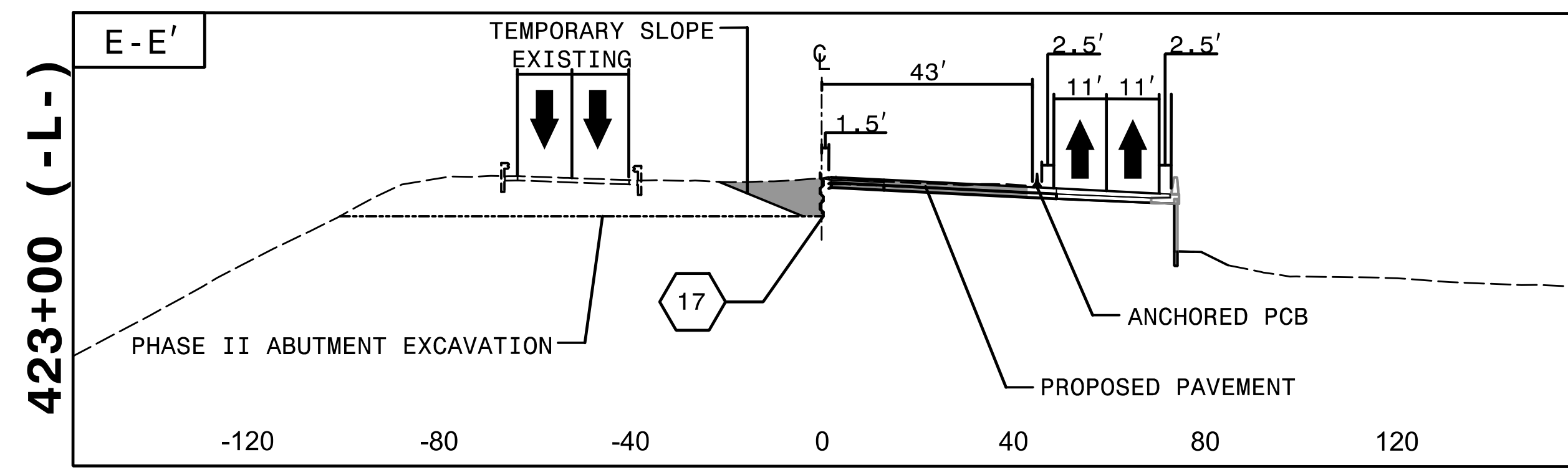
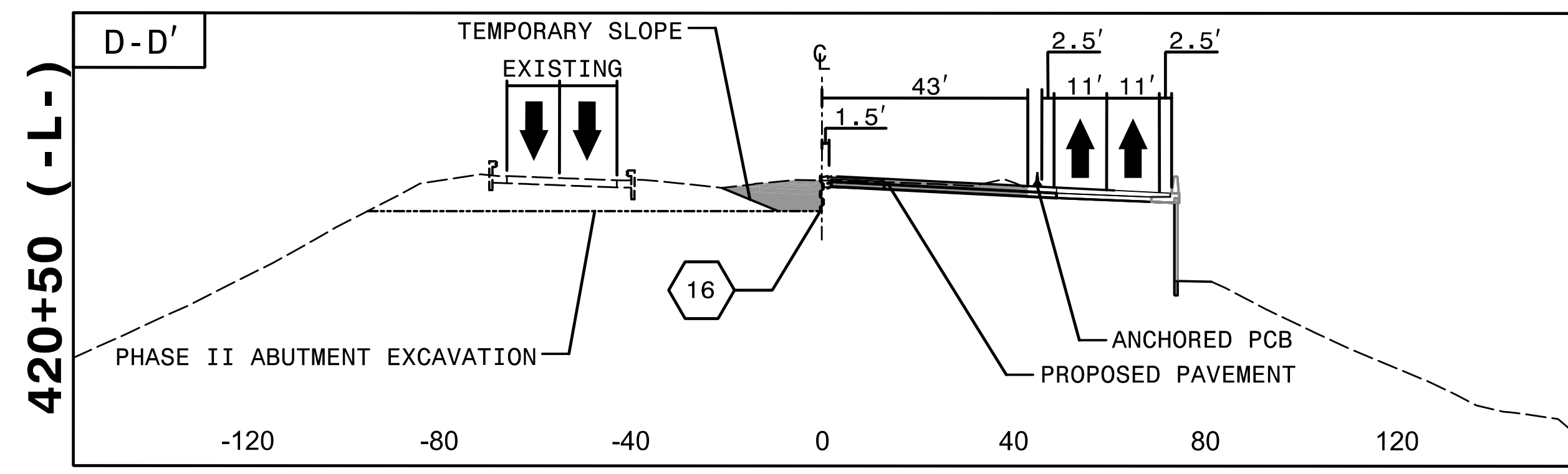
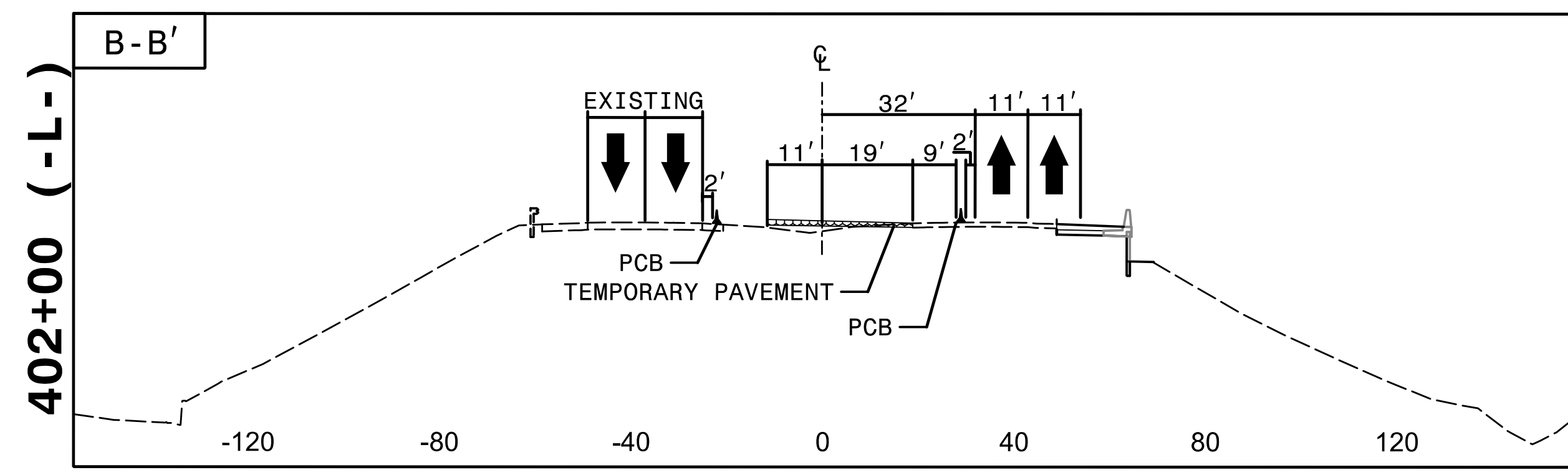
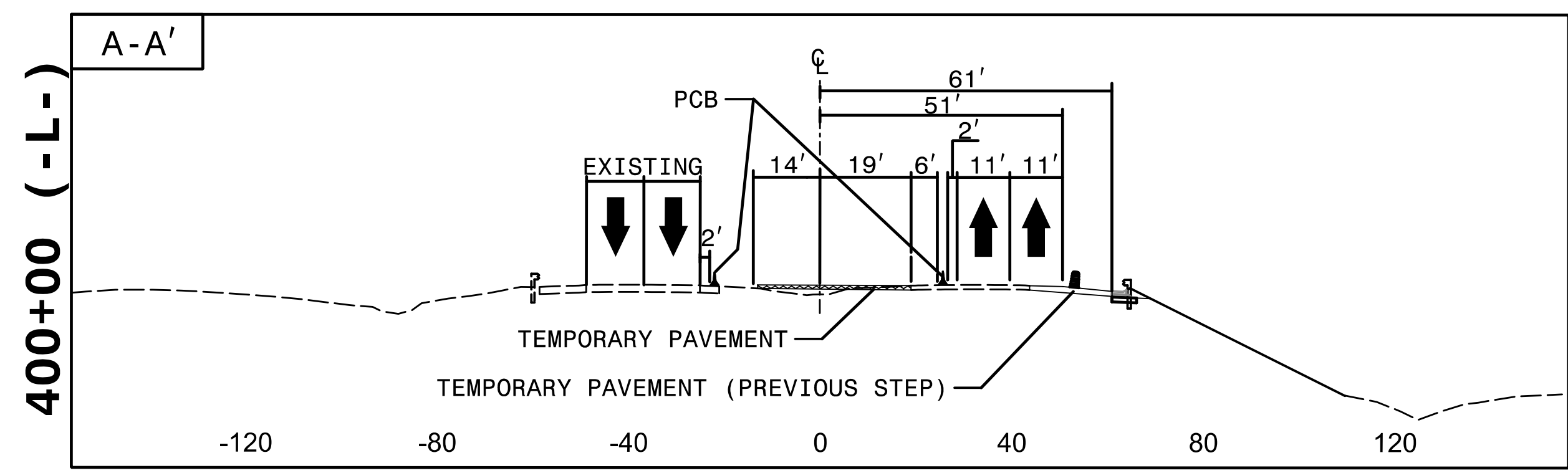

12:38:42 PM
I:\CP\4400BB-TC-PI\CUTS.dgn
9/3/2019

HNTB HNTB NORTH CAROLINA, P.C.
343 E. Six Forks Road, Suite 200
Raleigh, North Carolina 27609
NC License No: C-1554

APPROVED: *Rhonda B. Early*
DATE: 9/3/2019

PROFESSIONAL ENGINEER
NORTH CAROLINA
SEAL
023521
RHONDA B. EARLY

DOCUMENT NOT CONSIDERED FINAL
UNLESS ALL SIGNATURES COMPLETED

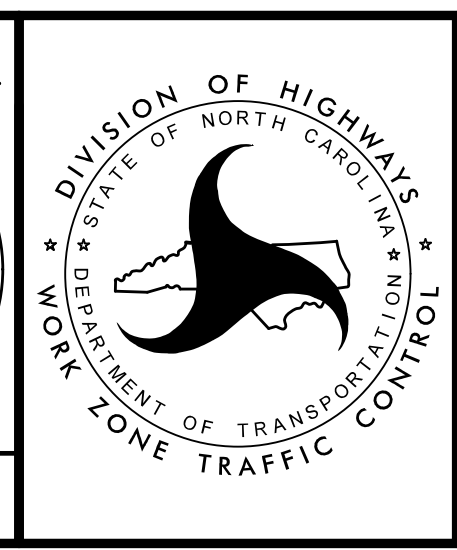

TRANSPORTATION
MANAGEMENT PLAN

PHASE I
CUT SECTIONS
STEP 6 THRU 9

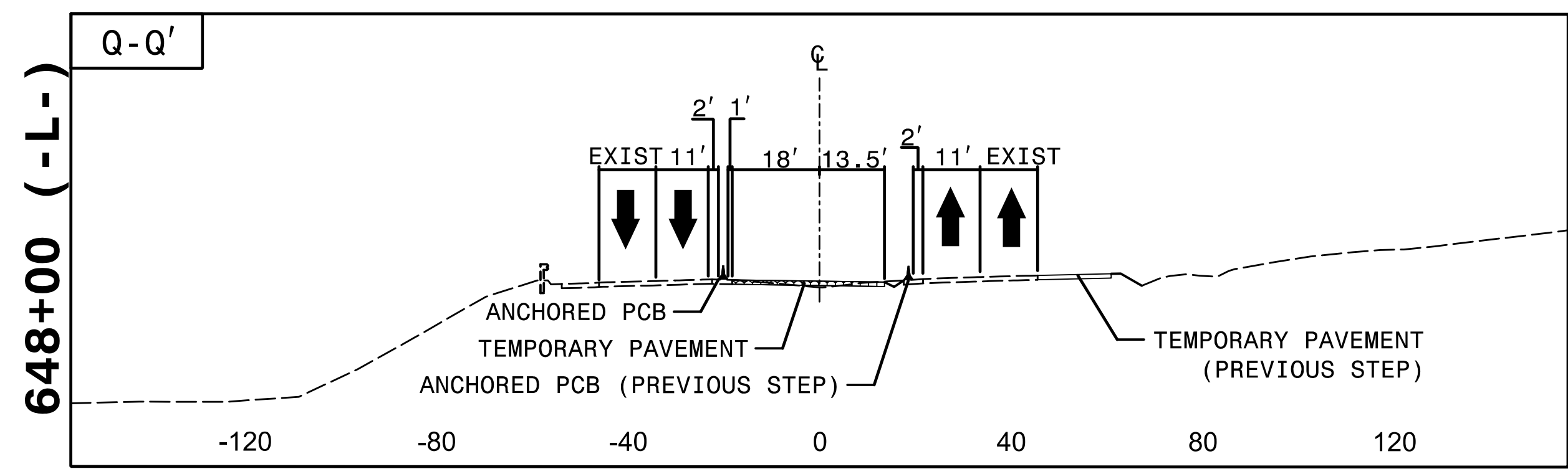
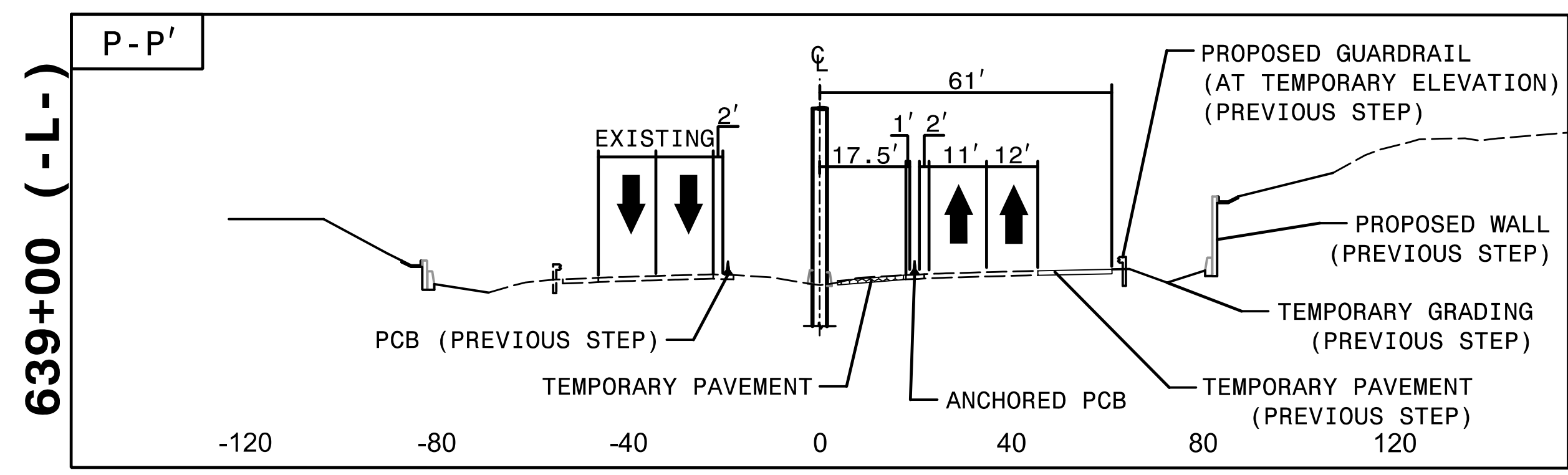
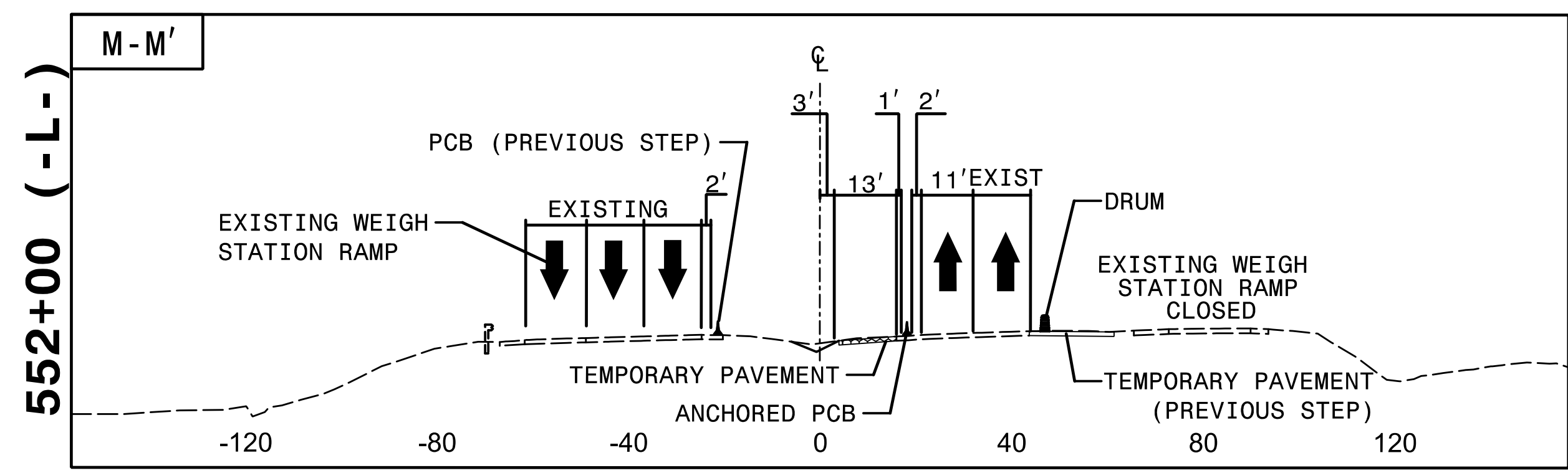

12:38:23 PM
 I:\CP\4400BB-TC-PI\CUTS.dgn
 9/3/2019

HNTB HNTB NORTH CAROLINA, P.C.
 343 E. Six Forks Road, Suite 200
 Raleigh, North Carolina 27609
 NC License No: C-1554

APPROVED: *Rhonda B. Early*
 DATE: 9/3/2019

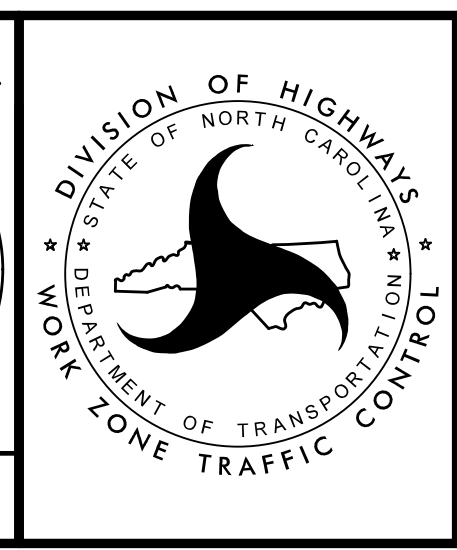

TRANSPORTATION
 MANAGEMENT PLAN

 PHASE I
 CUT SECTIONS
 STEP 6 THRU 9

DOCUMENT NOT CONSIDERED FINAL
UNLESS ALL SIGNATURES COMPLETED

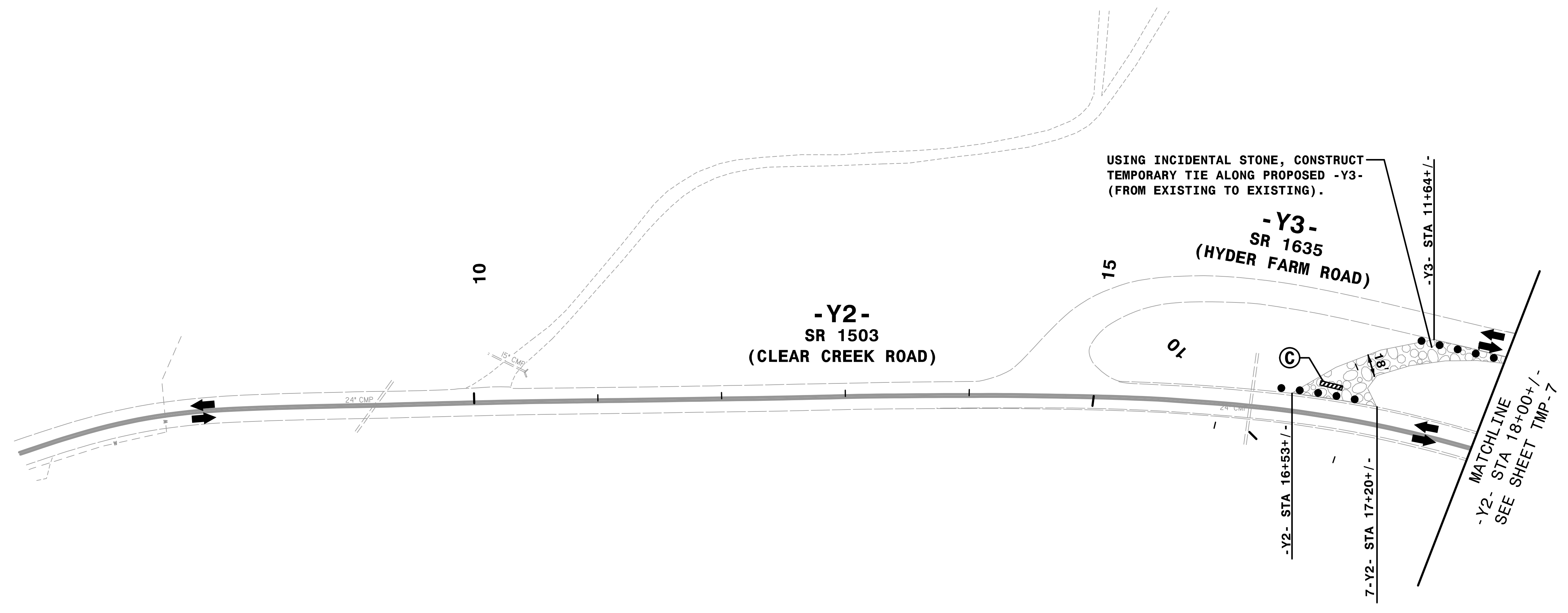
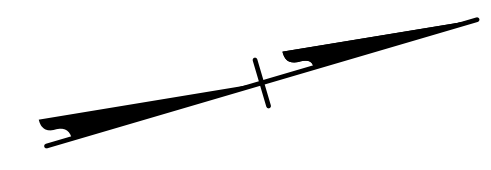
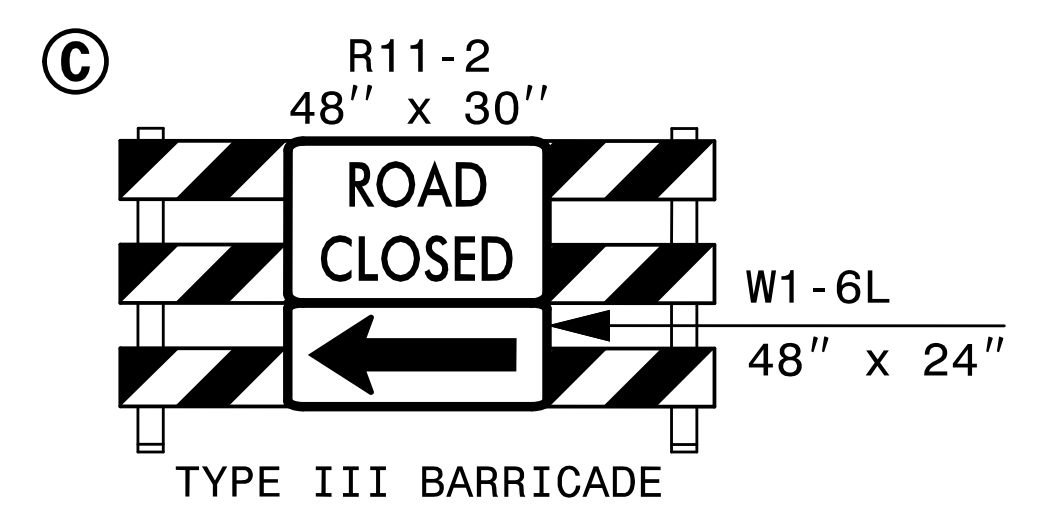

12:38:49 PM
 I:\CP\I-4400BB.tc.P\I2D01.dgn
 9/3/2019

STEPS 2.1 THRU 2.2

TRANSPORTATION
MANAGEMENT PLAN

PHASE I
DETAIL

APPROVED: *Rhonda B. Early*
DocuSigned by:
Rhonda B. Early
F34CAFAC0BF48A
 DATE: 9/3/2019

**DOCUMENT NOT CONSIDERED FINAL
UNLESS ALL SIGNATURES COMPLETED**

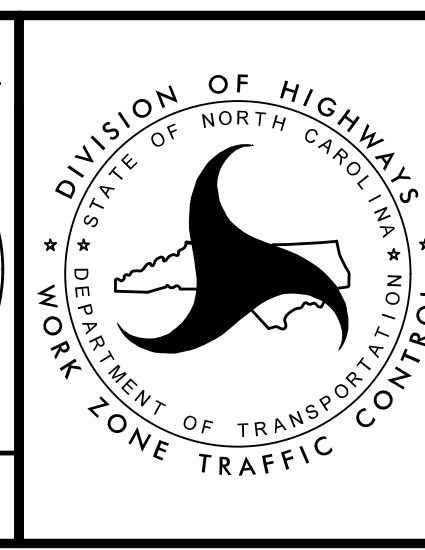

HNTB HNTB NORTH CAROLINA, P.C.
 343 E. Six Forks Road, Suite 200
 Raleigh, North Carolina 27609
 NC License No: C-1554

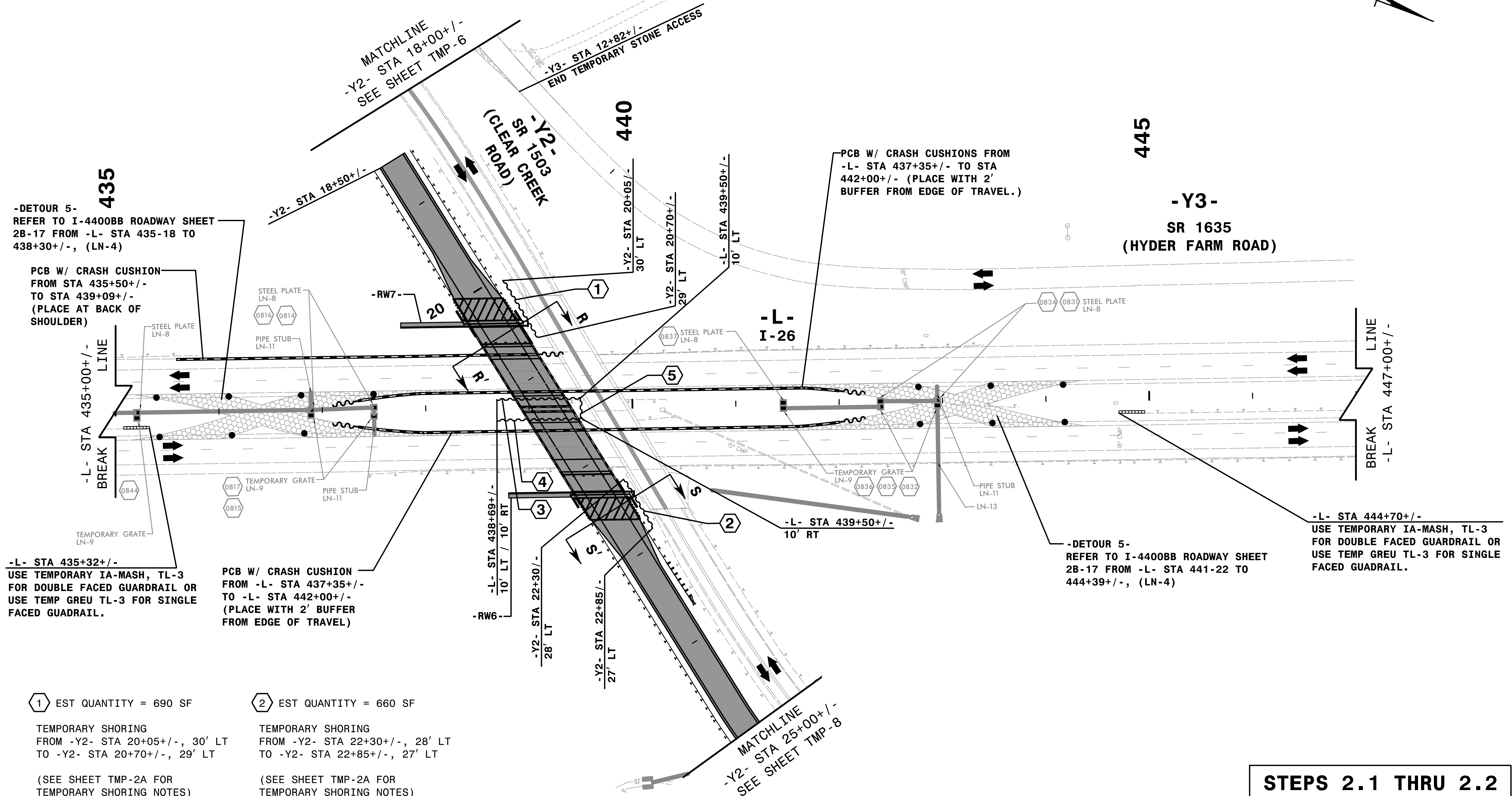
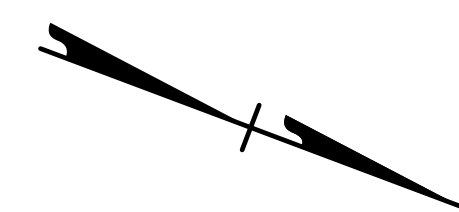

-DETOUR 5-
REFER TO I-4400BB ROADWAY SHEET
2B-17 FROM -L- STA 435-18 TO
438+30+/-, (LN-4)

PCB W/ CRASH CUSHION
FROM STA 435+50+/-
TO STA 439+09+/-
(PLACE AT BACK OF
SHOULDER)

-L- STA 435+32+/-
USE TEMPORARY IA-MASH, TL-3
FOR DOUBLE FACED GUARDRAIL OR
USE TEMP GREU TL-3 FOR SINGLE
FACED GUADRAIL.

PCB W/ CRASH CUSHION
FROM -L- STA 437+35+/-
TO -L- STA 442+00+/-
(PLACE WITH 2' BUFFER
FROM EDGE OF TRAVEL)

PCB W/ CRASH CUSHIONS FROM
-L- STA 437+35+/- TO STA
442+00+/- (PLACE WITH 2'
BUFFER FROM EDGE OF TRAVEL.)

-L- STA 444+70+/-
USE TEMPORARY IA-MASH, TL-3
FOR DOUBLE FACED GUARDRAIL OR
USE TEMP GREU TL-3 FOR SINGLE
FACED GUADRAIL.

-DETOUR 5-
REFER TO I-4400BB ROADWAY SHEET
2B-17 FROM -L- STA 441-22 TO
444+39+/-, (LN-4)

1 EST QUANTITY = 690 SF
TEMPORARY SHORING
FROM -Y2- STA 20+05+/-, 30' LT
TO -Y2- STA 20+70+/-, 29' LT

(SEE SHEET TMP-2A FOR
TEMPORARY SHORING NOTES)

2 EST QUANTITY = 660 SF
TEMPORARY SHORING
FROM -Y2- STA 22+30+/-, 28' LT
TO -Y2- STA 22+85+/-, 27' LT

(SEE SHEET TMP-2A FOR
TEMPORARY SHORING NOTES)

3 EST QUANTITY = 780 SF
TEMPORARY SHORING
FROM -L- STA 438+69+/-, 10' LT
TO -L- STA 439+50+/-, 10' LT

(SEE SHEET TMP-2A FOR
TEMPORARY SHORING NOTES)

4 EST QUANTITY = 780 SF
TEMPORARY SHORING
FROM -L- STA 438+69+/-, 10' RT
TO -L- STA 439+50+/-, 10' RT

(SEE SHEET TMP-2A FOR
TEMPORARY SHORING NOTES)

5 EST QUANTITY = 210 SF
TEMPORARY SHORING
FROM -L- STA 439+50+/-, 10' LT
TO -L- STA 439+50+/-, 10' RT

(SEE SHEET TMP-2A FOR
TEMPORARY SHORING NOTES)

REFER TO SHEET TMP-5 FOR CUT SECTIONS.

STEPS 2.1 THRU 2.2

12:38:57 PM
5/3/2019
I:\Projects\I-4400BB\TC_PL\Y2D02.dgn

HNTB HNTB NORTH CAROLINA, P.C.
343 E. Six Forks Road, Suite 200
Raleigh, North Carolina 27609
NC License No. C-1554

APPROVED: *Rhonda B. Early*
DATE: 9/3/2019

SEAL
NORTH CAROLINA
PROFESSIONAL
ENGINEER
RHONDA B. EARLY
023521

**DOCUMENT NOT CONSIDERED FINAL
UNLESS ALL SIGNATURES COMPLETED**

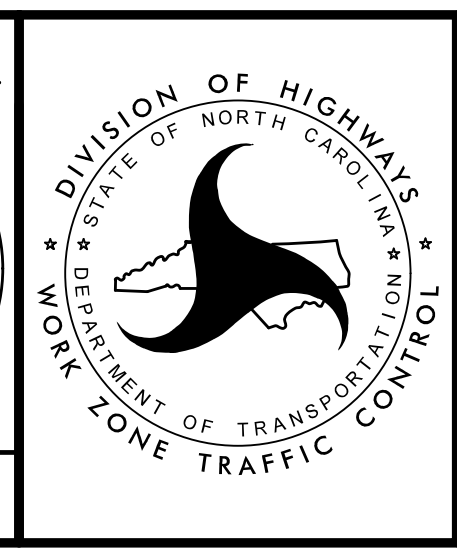

TRANSPORTATION
MANAGEMENT PLAN

**PHASE I
DETAIL**

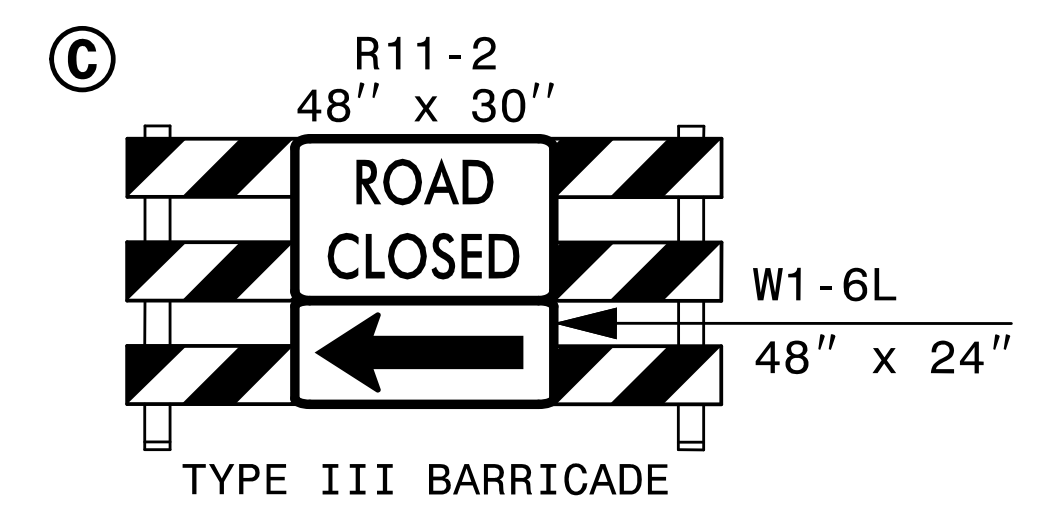
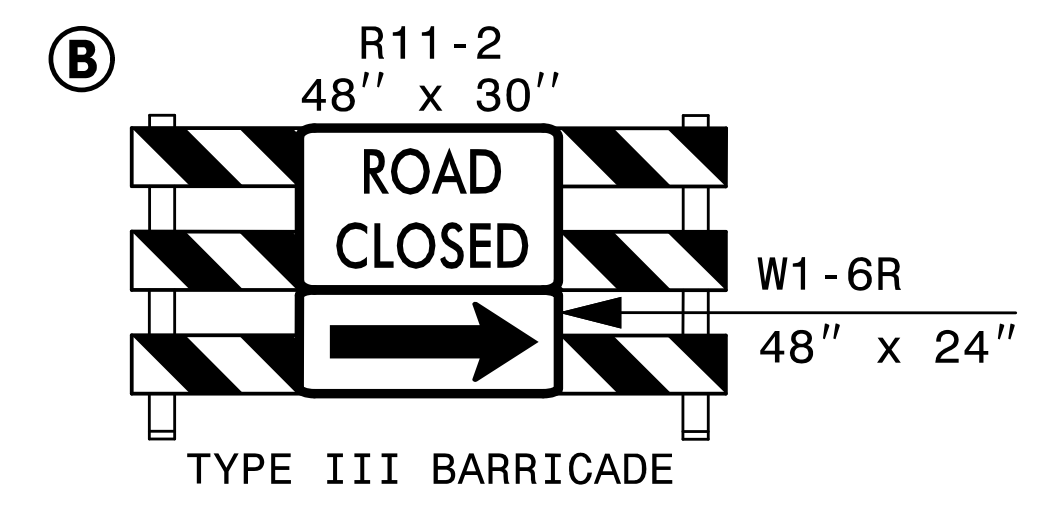
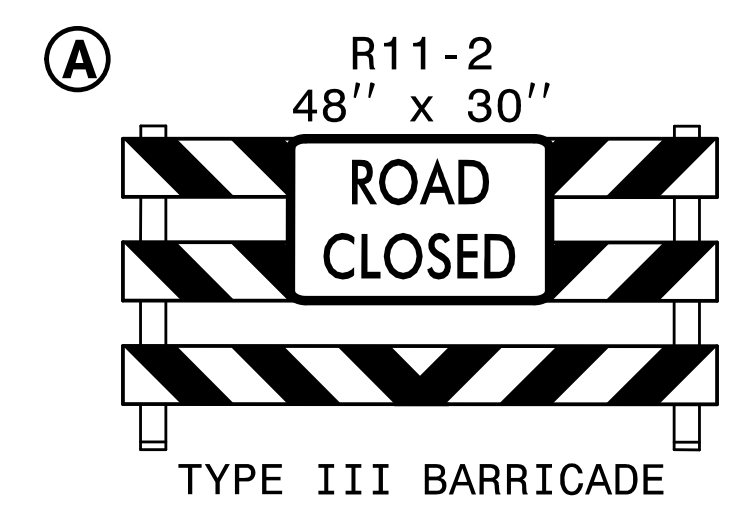
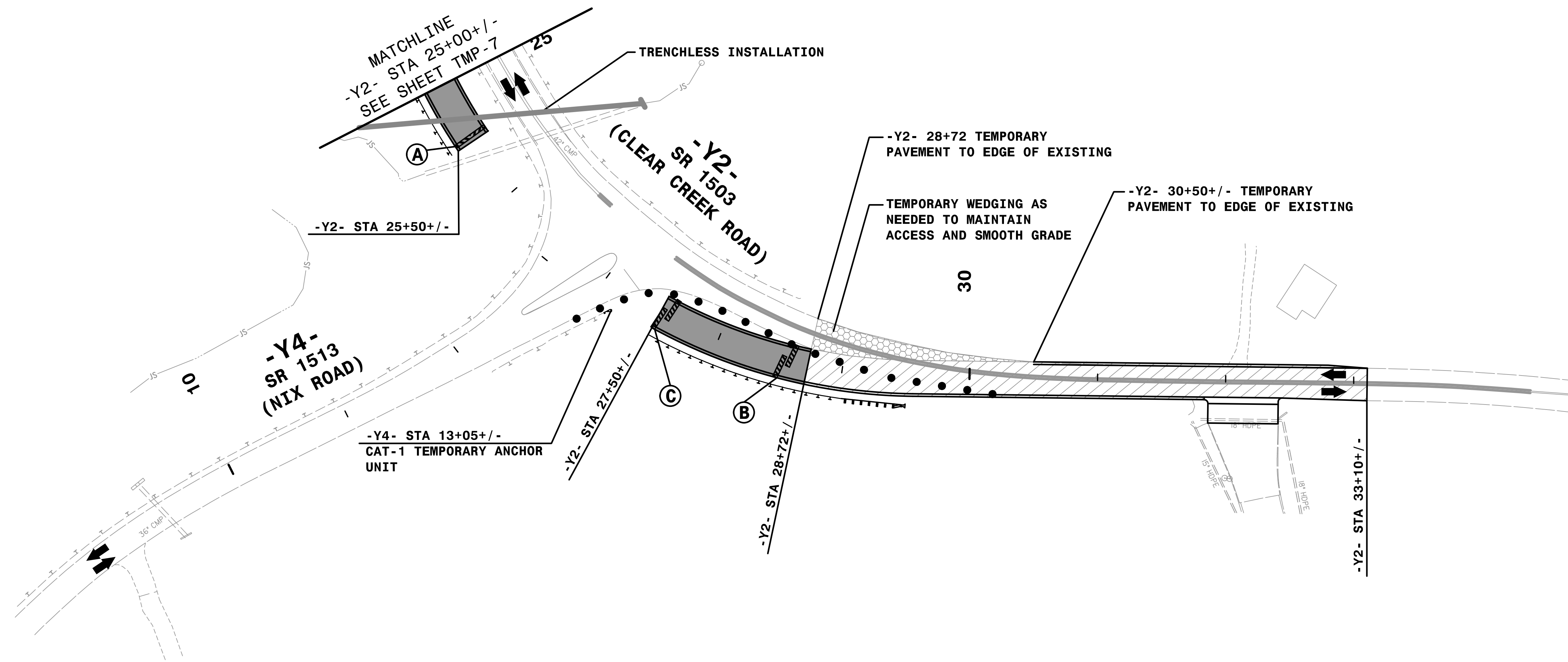
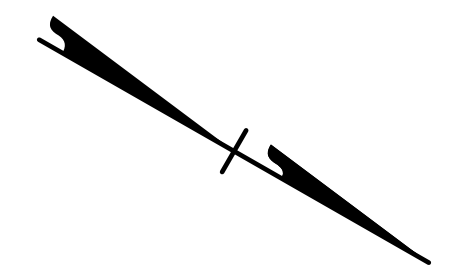

12:39:03 PM
 I:\CP\I-4400BB-1.c.pl\Y2D03.dgn
 9/3/2019

HNTB
 HNTB NORTH CAROLINA, P.C.
 343 E. Six Forks Road, Suite 200
 Raleigh, North Carolina 27609
 NC License No: C-1554

APPROVED: *Rhonda B. Early*
 DATE: 9/3/2019

**DOCUMENT NOT CONSIDERED FINAL
UNLESS ALL SIGNATURES COMPLETED**

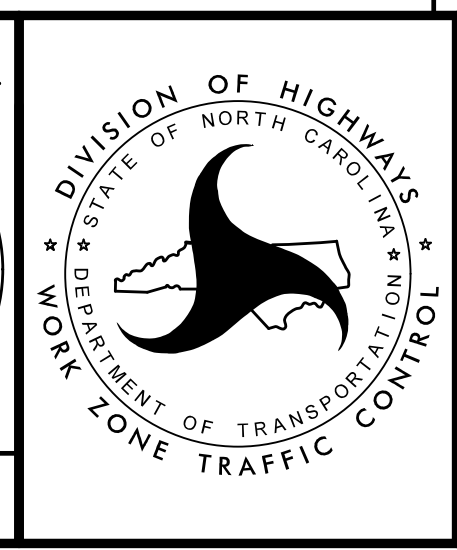

STEPS 2.1 THRU 2.2
 TRANSPORTATION
 MANAGEMENT PLAN

 PHASE I
 DETAIL

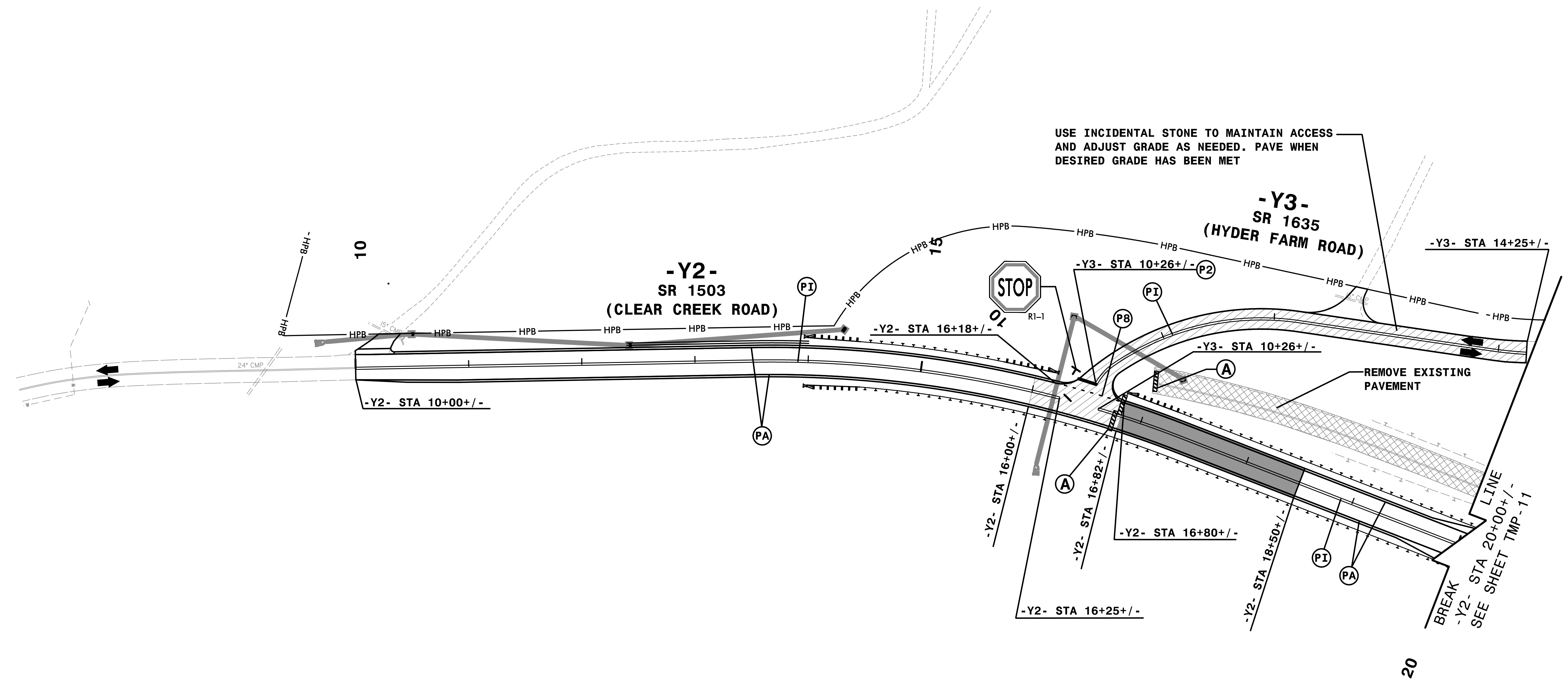
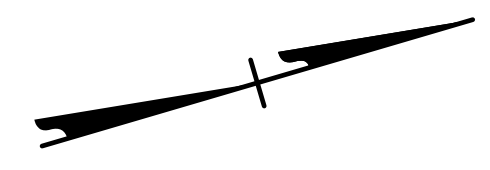
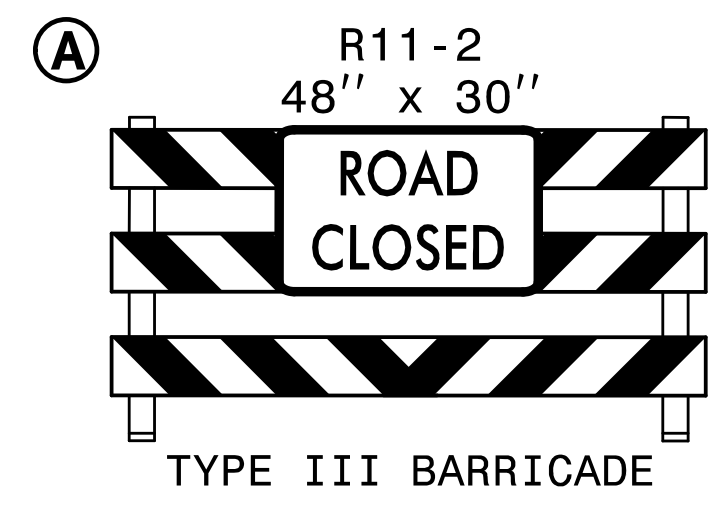

REFER TO SHEET TMP-5 FOR CUT SECTION.

REFER TO SHEET TMP-2E FOR OFF-SITE DETOUR.

STEP 2.5 THRU 2.7

APPROVED: *Rhonda B. Early*
DATE: 9/3/2019

DocuSigned by:
Rhonda B. Early
F34CAFAC0BF4BA
9/3/2019

PROFESSIONAL ENGINEER
NORTH CAROLINA
SEAL
023521
RHONDA B. EARLY

**DOCUMENT NOT CONSIDERED FINAL
UNLESS ALL SIGNATURES COMPLETED**

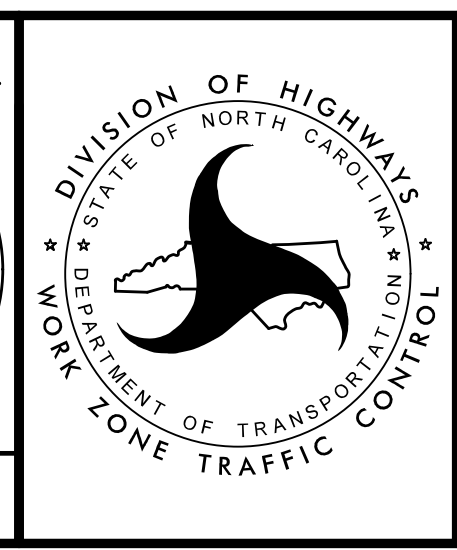

TRANSPORTATION
MANAGEMENT PLAN

**PHASE I
DETAIL**

HNTB HNTB NORTH CAROLINA, P.C.
343 E. Six Forks Road, Suite 200
Raleigh, North Carolina 27609
NC License No: C-1554

12:39:16 PM
I:\CP\I-4400BB-1.c.plb_Y2D01.dgn
9/3/2019

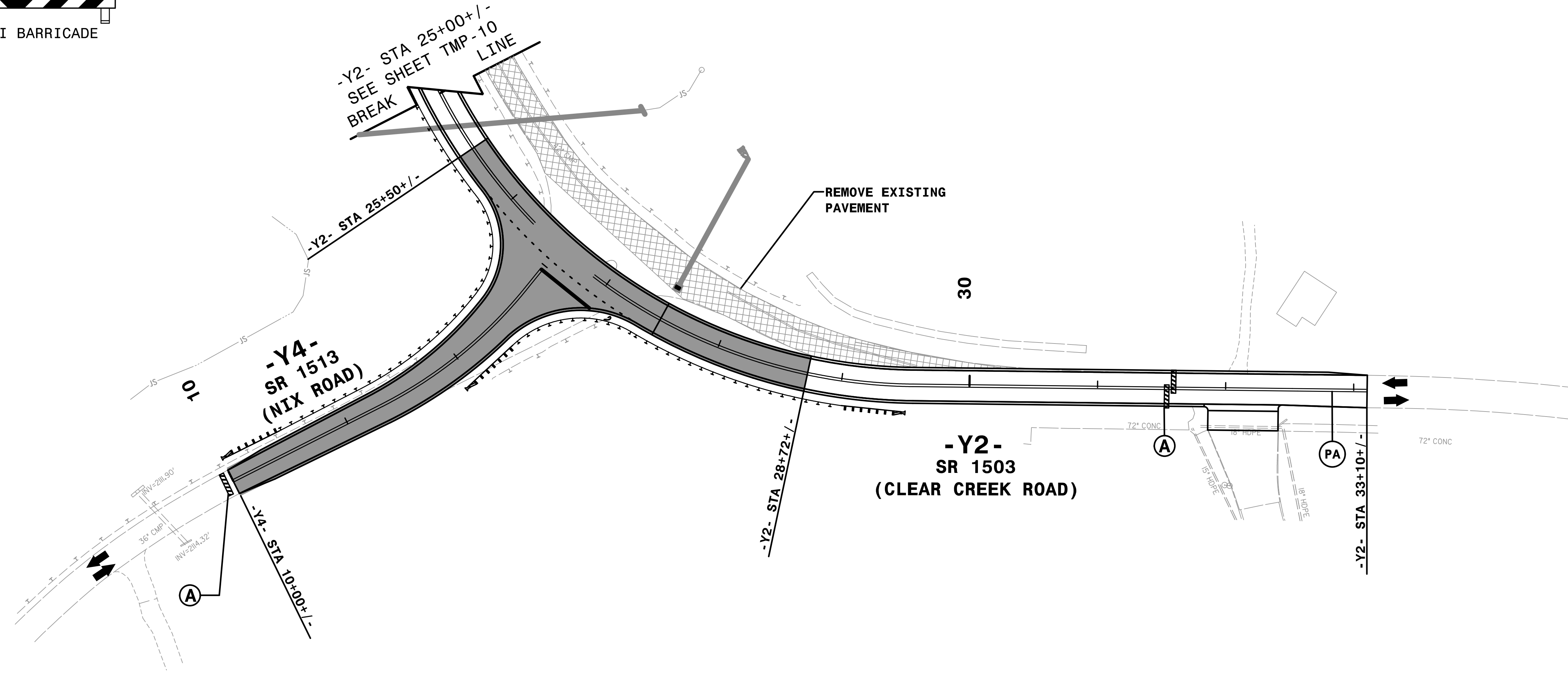
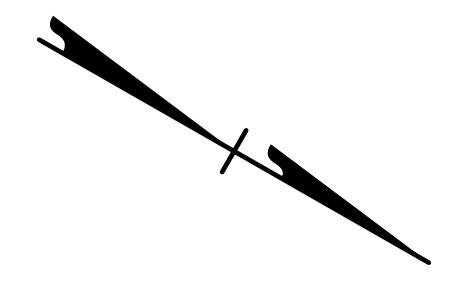
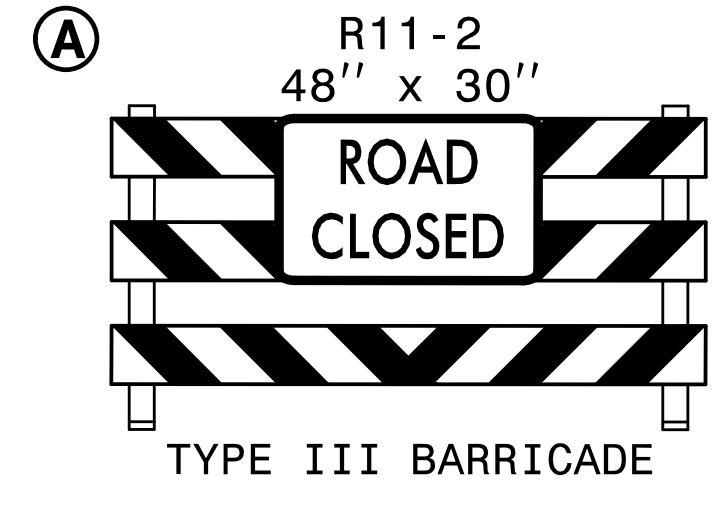

12:39:22 PM
 I:\CP\I-4400BB-1.c.plb_Y2D03.dgn
 9/3/2019

REFER TO SHEET TMP-2E FOR OFF-SITE DETOUR.

HNTB HNTB NORTH CAROLINA, P.C.
 343 E. SIX FORKS ROAD, SUITE 200
 RALEIGH, NORTH CAROLINA 27609
 NC LICENSE NO: C-1554

APPROVED: *Rhonda B. Early*
DocuSigned by:
Rhonda B. Early
F34CAFAC6BF4BA
 DATE: 9/3/2019

**DOCUMENT NOT CONSIDERED FINAL
 UNLESS ALL SIGNATURES COMPLETED**

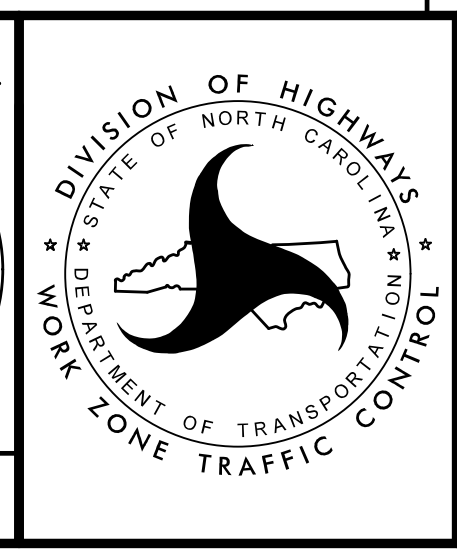

STEPS 2.5 THRU 2.7

TRANSPORTATION
 MANAGEMENT PLAN

PHASE I
 DETAIL

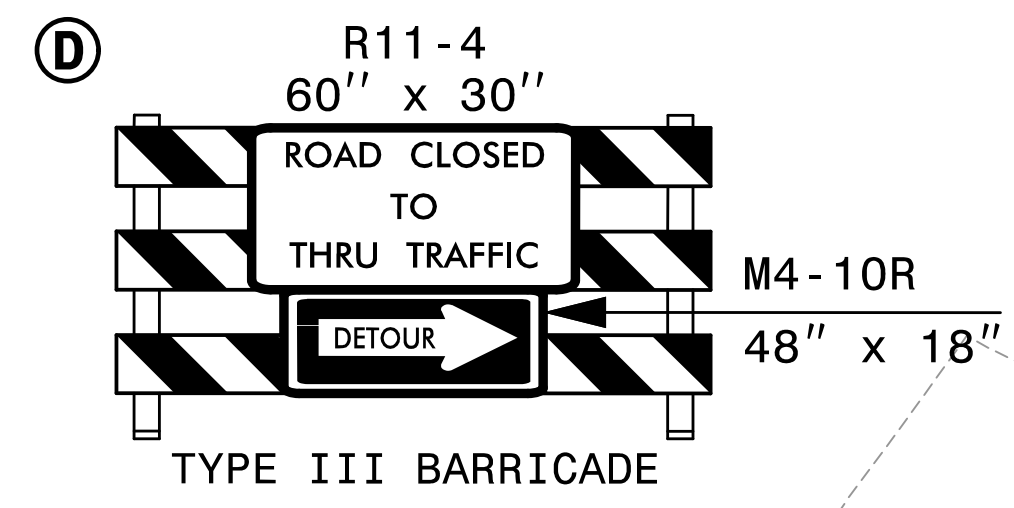
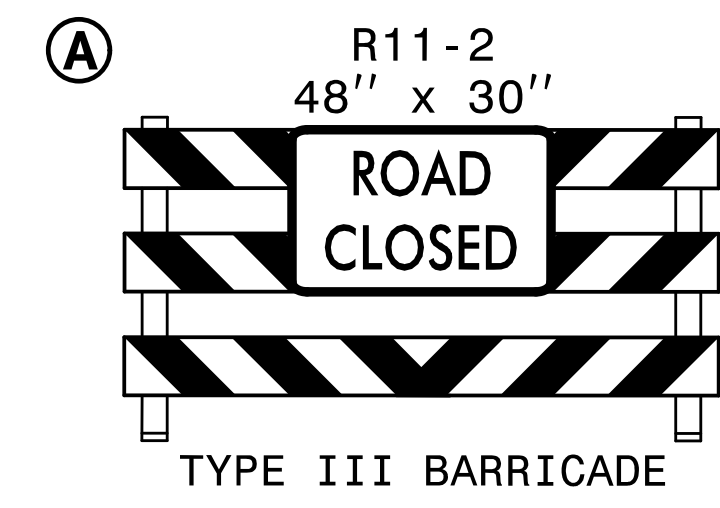

6 EST QUANTITY = 480 SF
TEMPORARY SHORING
FROM -Y5- STA 18+09+/-, 37' LT
TO -Y5- STA 18+57+/-, 39' LT

(SEE SHEET TMP-2A FOR
TEMPORARY SHORING NOTES)

8 EST QUANTITY = 850 SF
TEMPORARY SHORING
FROM -L- STA 539+52+/-, 10' LT
TO -L- STA 540+42+/-, 10' LT

(SEE SHEET TMP-2A.1 FOR
TEMPORARY SHORING NOTES)

7 EST QUANTITY = 470 SF
TEMPORARY SHORING
FROM -Y5- STA 20+03+/-, 39' LT
TO -Y5- STA 20+55+/-, 37' LT

(SEE SHEET TMP-2A.1 FOR
TEMPORARY SHORING NOTES)

9 EST QUANTITY = 860 SF
TEMPORARY SHORING
FROM -L- STA 539+52+/-, 10' RT
TO -L- STA 540+42+/-, 10' RT

(SEE SHEET TMP-2A.1 FOR
TEMPORARY SHORING NOTES)

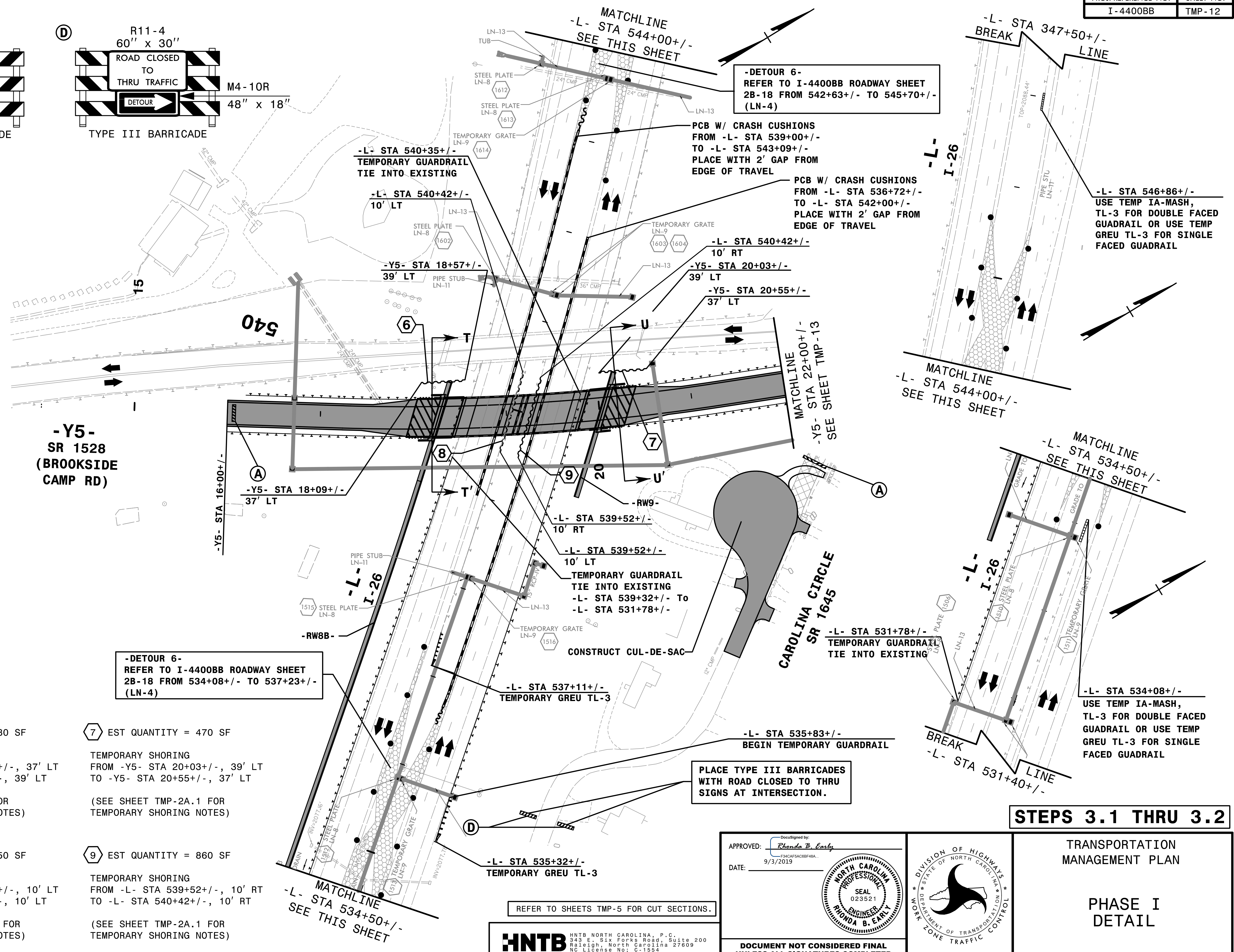

-DETOUR 6-
REFER TO I-4400BB ROADWAY SHEET
2B-18 FROM 542+63+/- TO 545+70+/-
(LN-4)

PCB W/ CRASH CUSHIONS
FROM -L- STA 539+00+/-
TO -L- STA 543+09+/-
PLACE WITH 2' GAP FROM
EDGE OF TRAVEL

PCB W/ CRASH CUSHIONS
FROM -L- STA 536+72+/-
TO -L- STA 542+00+/-
PLACE WITH 2' GAP FROM
EDGE OF TRAVEL

-L- STA 546+86+/-
USE TEMP IA-MASH,
TL-3 FOR DOUBLE FACED
GUARDRAIL OR USE TEMP
GREU TL-3 FOR SINGLE
FACED GUARDRAIL

MATCHLINE
-L- STA 544+00+/-
SEE THIS SHEET

MATCHLINE
-L- STA 534+50+/-
SEE THIS SHEET

-DETOUR 6-
REFER TO I-4400BB ROADWAY SHEET
2B-18 FROM 534+08+/- TO 537+23+/-
(LN-4)

PLACE TYPE III BARRICADES
WITH ROAD CLOSED TO THRU
SIGNS AT INTERSECTION.

STEPS 3.1 THRU 3.2

TRANSPORTATION
MANAGEMENT PLAN

PHASE I
DETAIL

APPROVED: Rhonda B. Early
DATE: 9/3/2019
NORTH CAROLINA PROFESSIONAL ENGINEER SEAL 023521
RHONDA B. EARLY
DOCUMENT NOT CONSIDERED FINAL
UNLESS ALL SIGNATURES COMPLETED

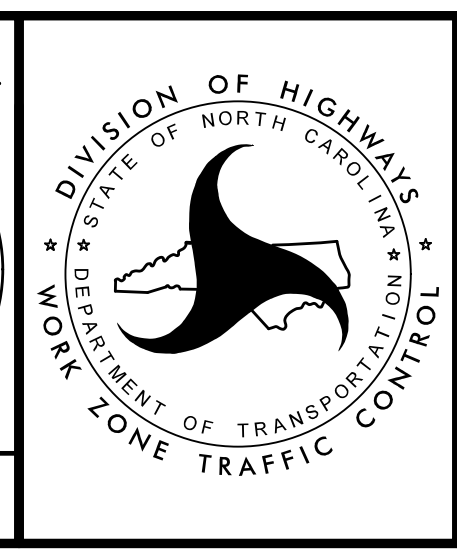

HNTB
HNTB NORTH CAROLINA, P.C.
343 E. Six Forks Road, Suite 200
Raleigh, North Carolina 27609
NC License No: C-1554

12:39:29 PM
\\TC\N-4400BB-1.c.pl\Y5D01.dgn
9/3/2019

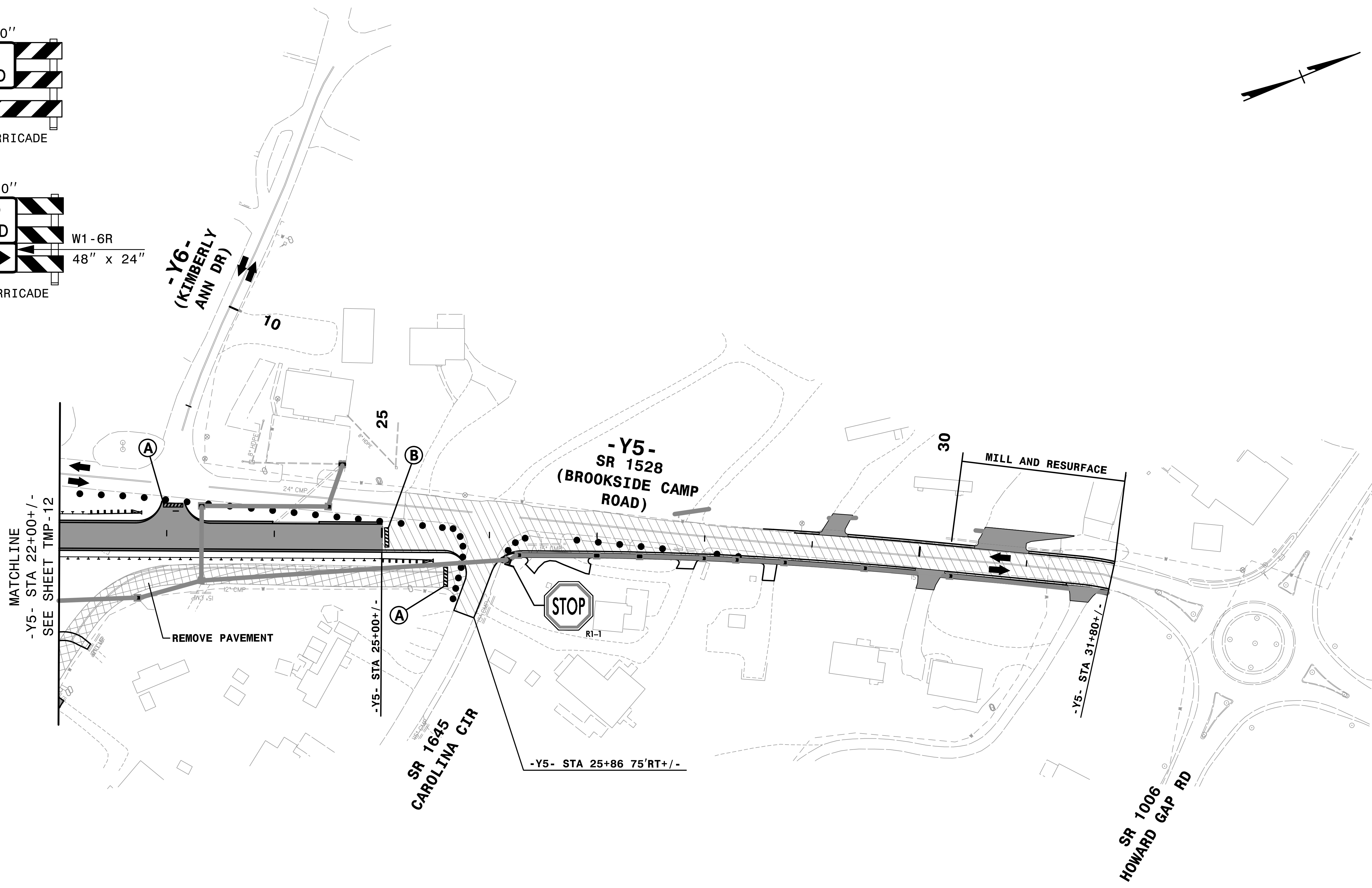
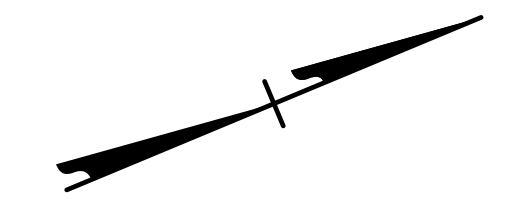
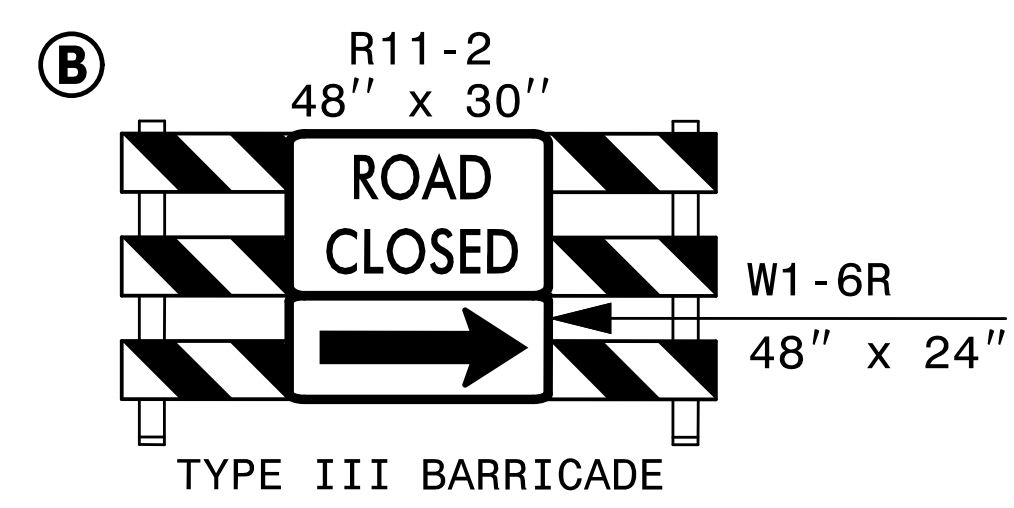
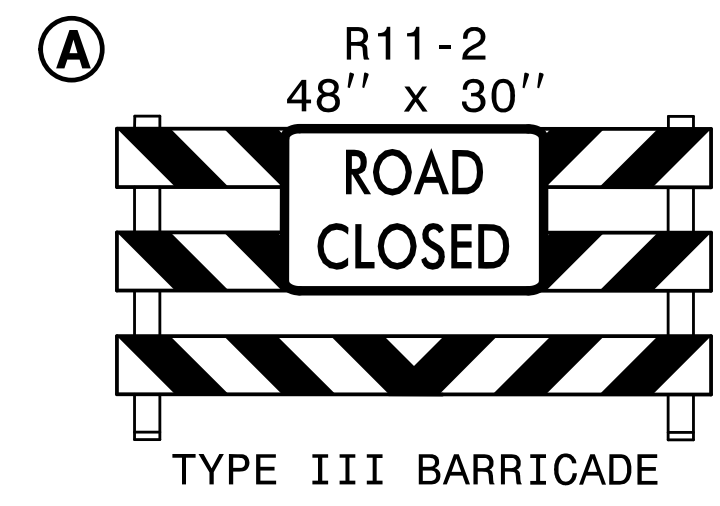

STEPS 3.1 THRU 3.2

12:39:35 PM
I:\CP\I-4400BB-1.c.pl\Y5D02.dgn
9/3/2019

HNTB
HNTB NORTH CAROLINA, P.C.
343 E. Six Forks Road, Suite 200
Raleigh, North Carolina 27609
NC License No: C-1554

APPROVED: *Rhonda B. Early*
F34CAFAC6BF4BA
DATE: 9/3/2019

SEAL
NORTH CAROLINA
PROFESSIONAL
ENGINEERS
RHONDA B. EARLY
023521

**DOCUMENT NOT CONSIDERED FINAL
UNLESS ALL SIGNATURES COMPLETED**

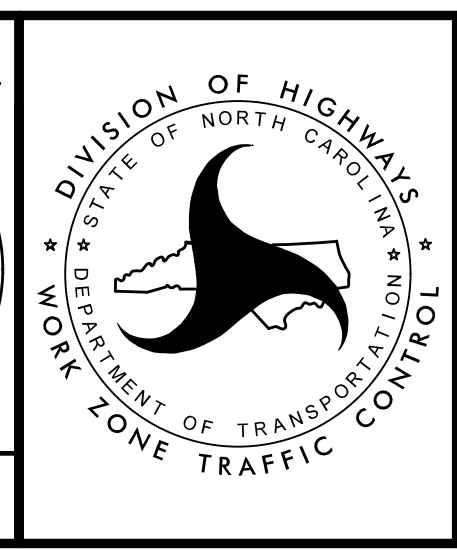

TRANSPORTATION
MANAGEMENT PLAN

PHASE I
DETAIL

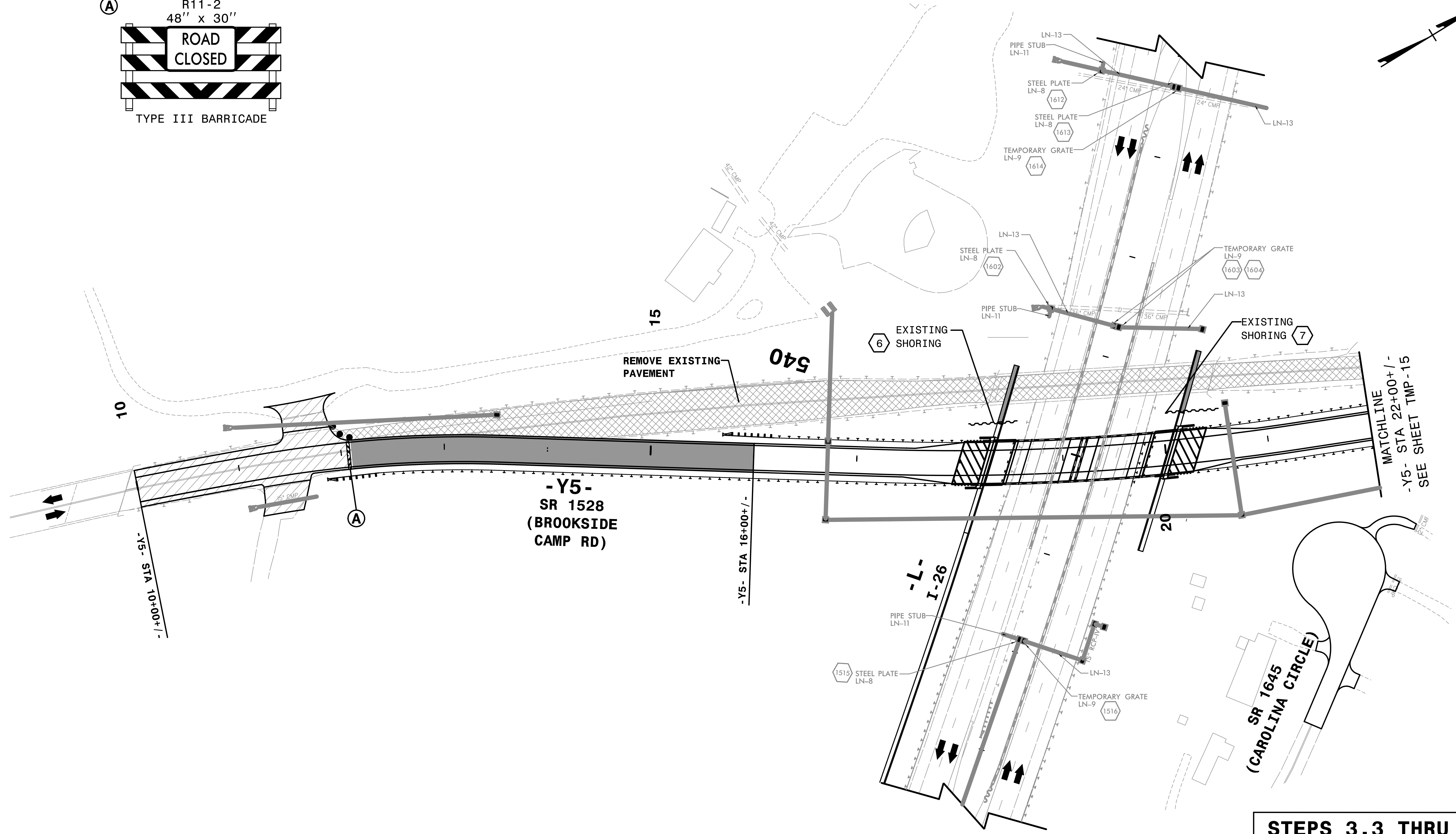
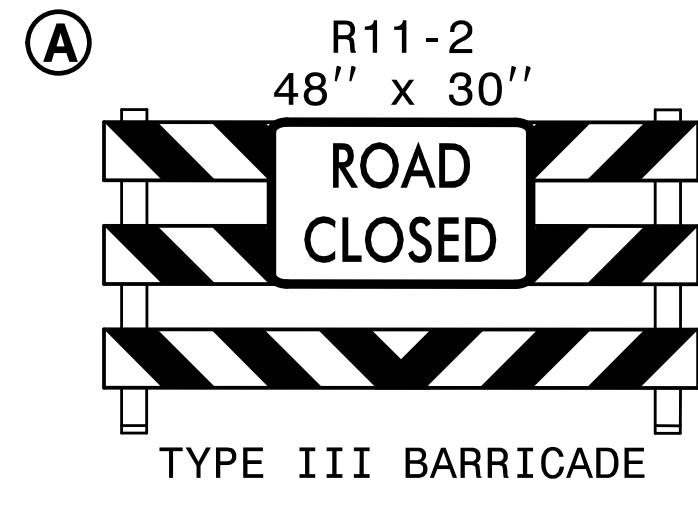

REFER TO SHEET TMP-2F FOR OFF-SITE DETOUR.

STEPS 3.3 THRU 3.6

TRANSPORTATION
MANAGEMENT PLAN

PHASE I
DETAIL

APPROVED: *Rhonda B. Early*
F34CAFAC6BF4BA...
 DATE: 9/3/2019

**DOCUMENT NOT CONSIDERED FINAL
UNLESS ALL SIGNATURES COMPLETED**

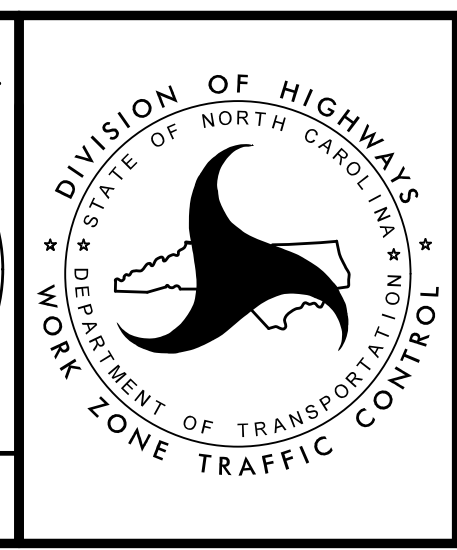

HNTB HNTB NORTH CAROLINA, P.C.
 343 E. Six Forks Road, Suite 200
 Raleigh, North Carolina 27609
 NC License No: C-1554

12:39:41 PM
 I:\CP\I-4400BB-1.c.pla_Y5D01.dgn
 9/3/2019

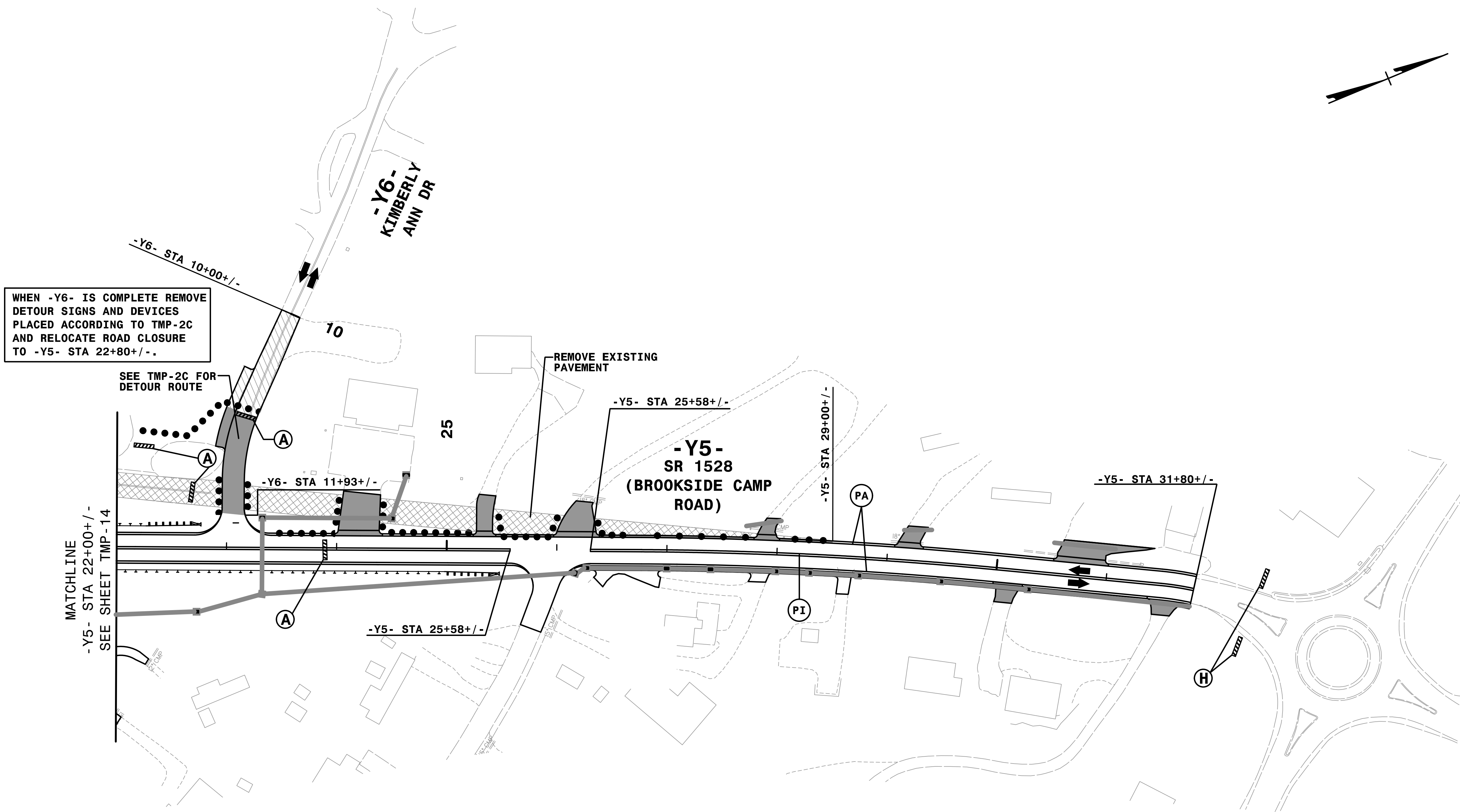
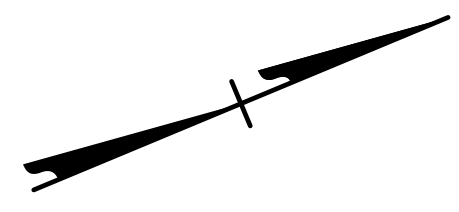

WHEN -Y6- IS COMPLETE REMOVE
DETOUR SIGNS AND DEVICES
PLACED ACCORDING TO TMP-2C
AND RELOCATE ROAD CLOSURE
TO -Y5- STA 22+80+/-.

SEE TMP-2C FOR
DETOUR ROUTE

REMOVE EXISTING
PAVEMENT

MATCHLINE
-Y5- STA 22+00+/-
SEE SHEET TMP-14

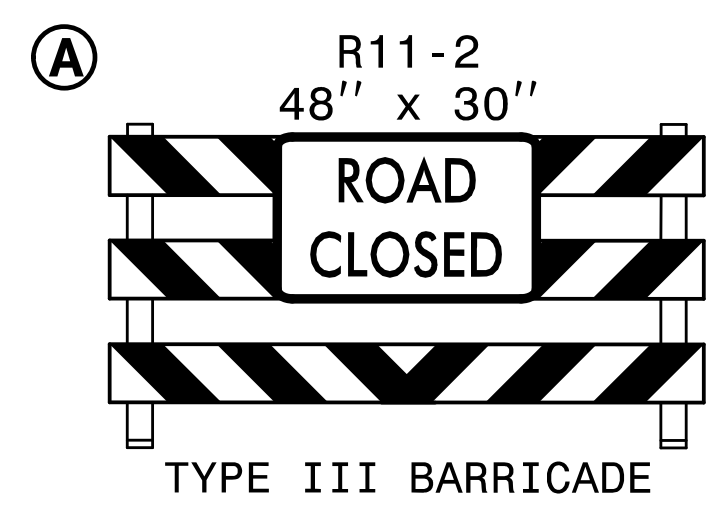

TYPE III BARRICADE

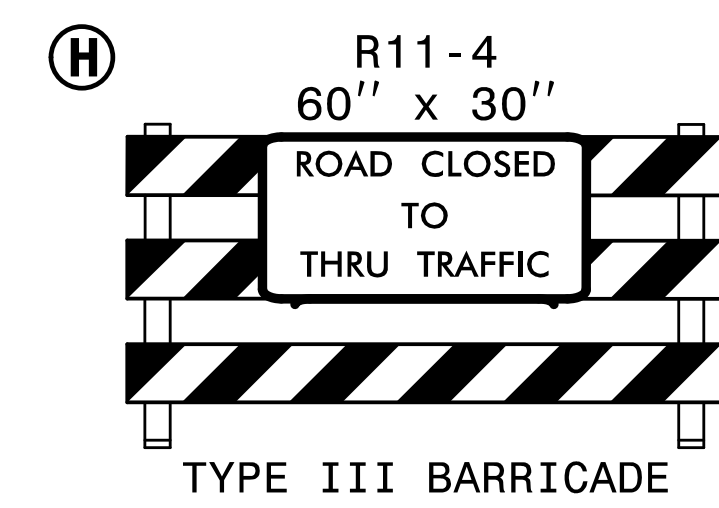

TYPE III BARRICADE

REFER TO SHEET TMP-2C FOR -Y6- DETOUR DETAIL.

REFER TO SHEET TMP-2F FOR -Y5- DETOUR DETAIL.

STEPS 3.3 THRU 3.6

TRANSPORTATION
MANAGEMENT PLAN

PHASE I
DETAIL

APPROVED: *Rhonda B. Early*
F34CAF5ACBF4BA
DATE: 9/3/2019

**DOCUMENT NOT CONSIDERED FINAL
UNLESS ALL SIGNATURES COMPLETED**

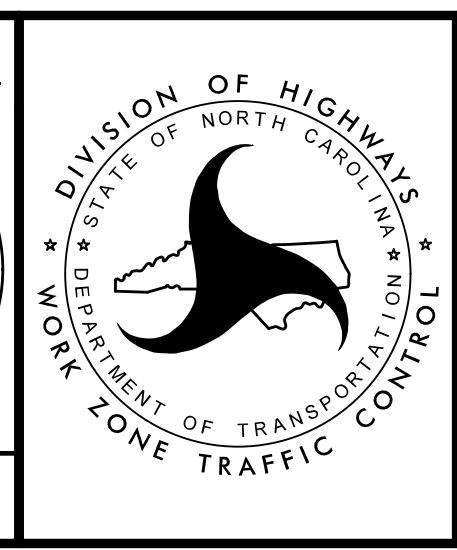

HNTB HNTB NORTH CAROLINA, P.C.
343 E. SIX FORKS ROAD, SUITE 200
RALEIGH, NORTH CAROLINA 27609
NC LICENSE NO: C-1554

12:39:47 PM
I:\CPN\I-4400BB.t.c.Pla_Y5D02.dgn
9/3/2019

10 EST QUANTITY = 400 SF
 TEMPORARY SHORING
 FROM -Y7- STA 15+45+/-, 38' LT
 TO -Y7- STA 15+93+/-, 43' LT
 (SEE SHEET TMP-2A.1 FOR
 TEMPORARY SHORING NOTES)

12 EST QUANTITY = 1070 SF
 TEMPORARY SHORING
 FROM -L- STA 638+71+/-, 10' LT
 TO -L- STA 639+77+/-, 10' LT
 (SEE SHEET TMP-2A.1 FOR
 TEMPORARY SHORING NOTES)

11 EST QUANTITY = 800 SF
 TEMPORARY SHORING
 FROM -Y7- STA 17+62+/-, 45' LT
 TO -Y7- STA 18+35+/-, 57' LT
 (SEE SHEET TMP-2A.1 FOR
 TEMPORARY SHORING NOTES)

13 EST QUANTITY = 1070 SF
 TEMPORARY SHORING
 FROM -L- STA 638+71+/-, 10' RT
 TO -L- STA 639+77+/-, 10' RT
 (SEE SHEET TMP-2A.2 FOR
 TEMPORARY SHORING NOTES)

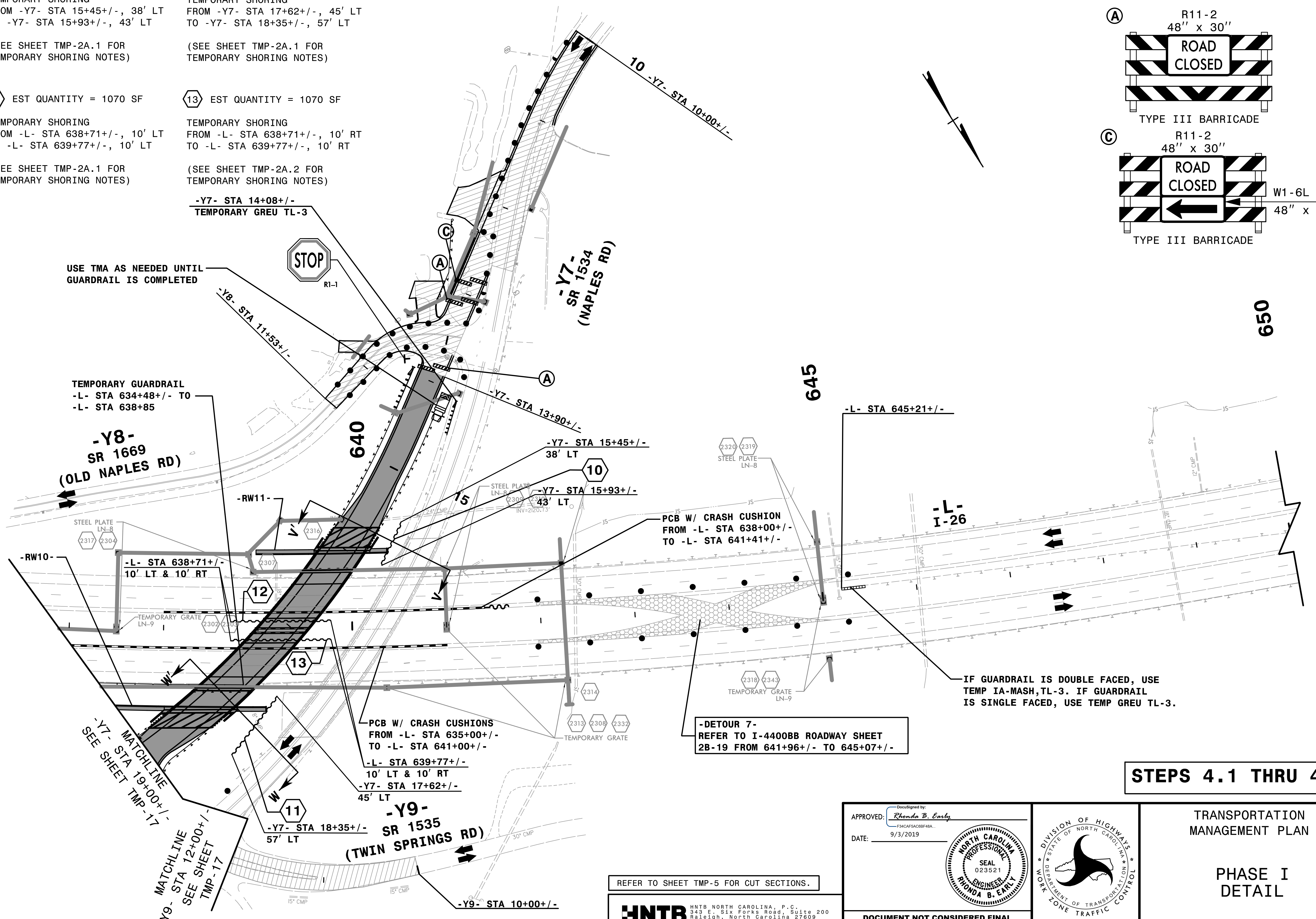
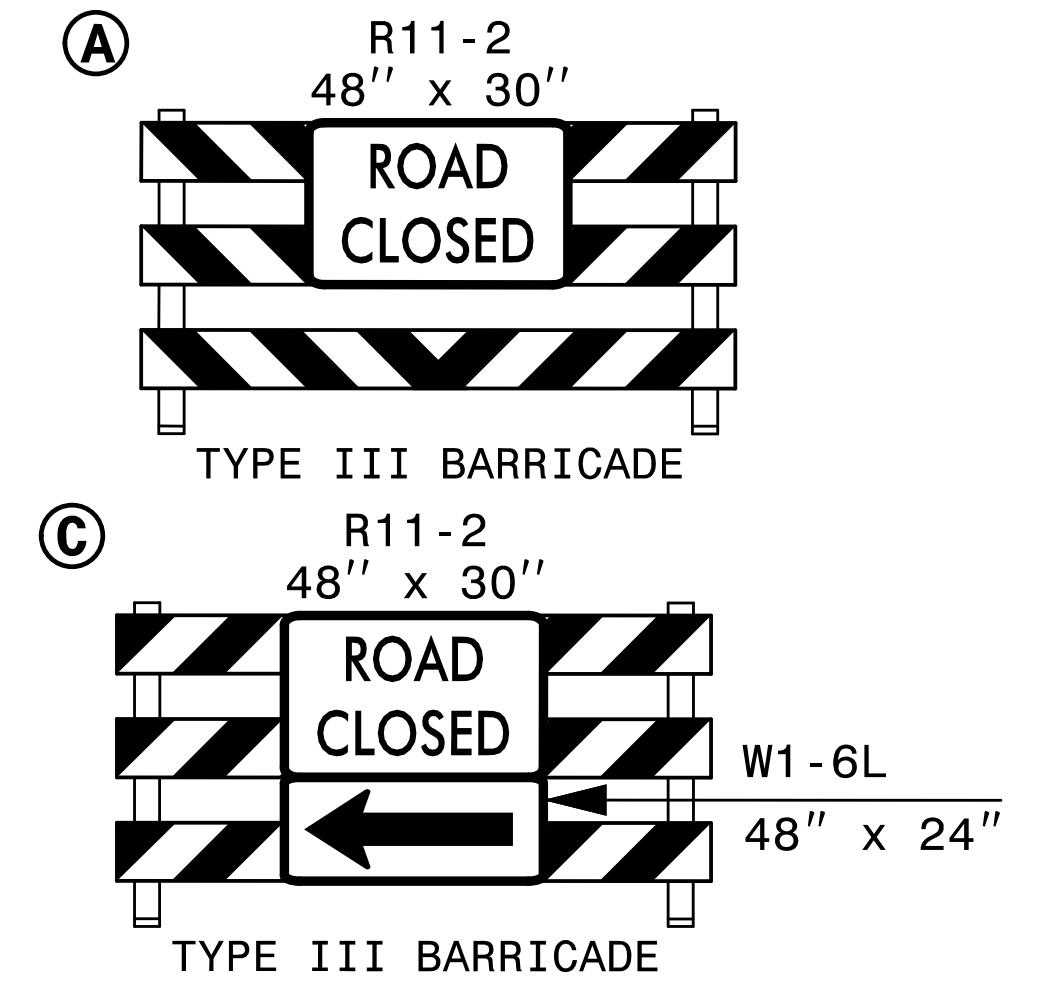

USE TMA AS NEEDED UNTIL
 GUARDRAIL IS COMPLETED

TEMPORARY GUARDRAIL
 -L- STA 634+48+/- TO
 -L- STA 638+85

-Y8-
 SR 1669
 (OLD NAPLES RD)

-L- STA 638+71+/-
 10' LT & 10' RT

PCB W/ CRASH CUSHIONS
 FROM -L- STA 635+00+/-
 TO -L- STA 641+00+/-

-DETOUR 7-
 REFER TO I-4400BB ROADWAY SHEET
 2B-19 FROM 641+96+/- TO 645+07+/-

IF GUARDRAIL IS DOUBLE FACED, USE
 TEMP IA-MASH, TL-3. IF GUARDRAIL
 IS SINGLE FACED, USE TEMP GREU TL-3.

STEPS 4.1 THRU 4.4

12:39:53 PM
 I:\CP\I-4400BB-1.c.pl\YTD01.dgn
 9/3/2019

REFER TO SHEET TMP-5 FOR CUT SECTIONS.

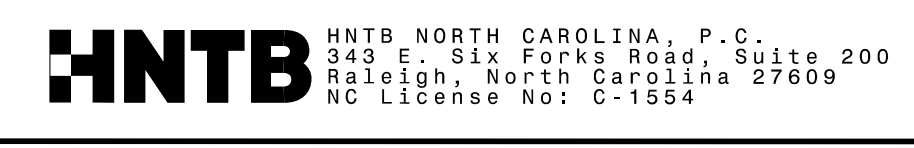

APPROVED: *Rhonda B. Early*
 DATE: 9/3/2019

DOCUMENT NOT CONSIDERED FINAL
 UNLESS ALL SIGNATURES COMPLETED

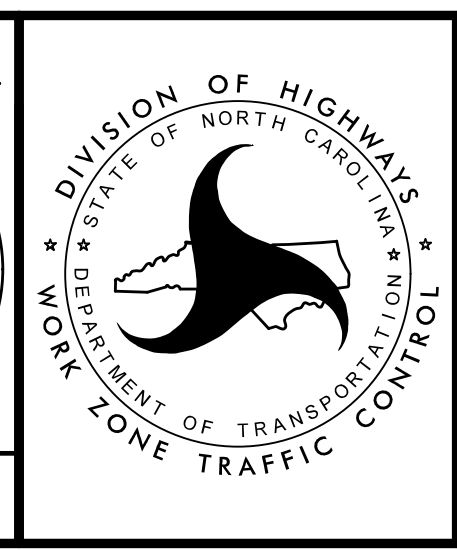

TRANSPORTATION
 MANAGEMENT PLAN

PHASE I
 DETAIL

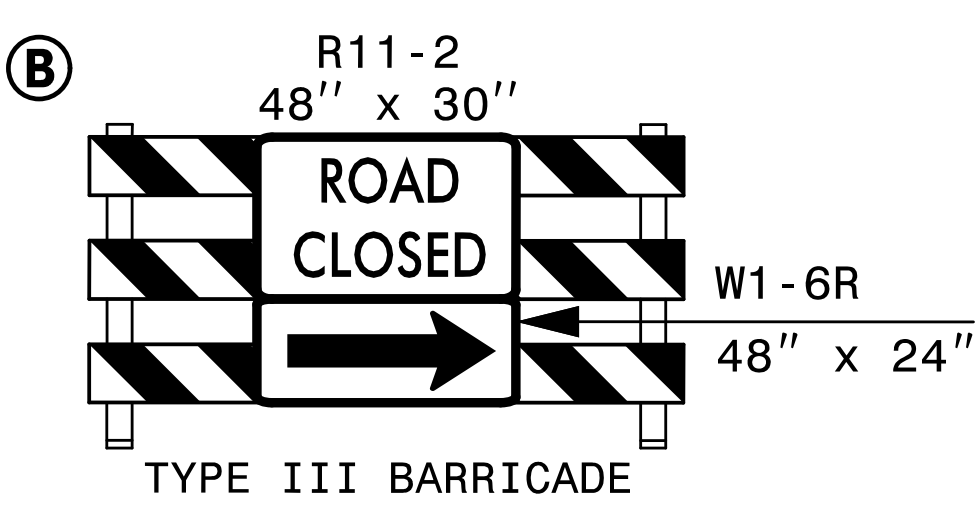
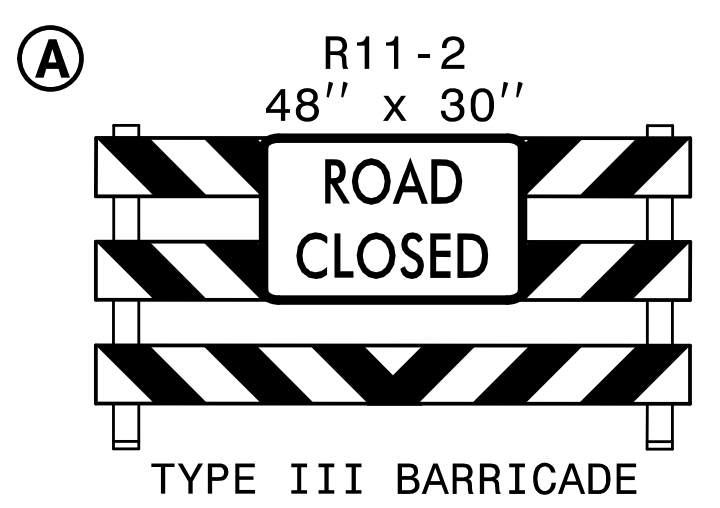
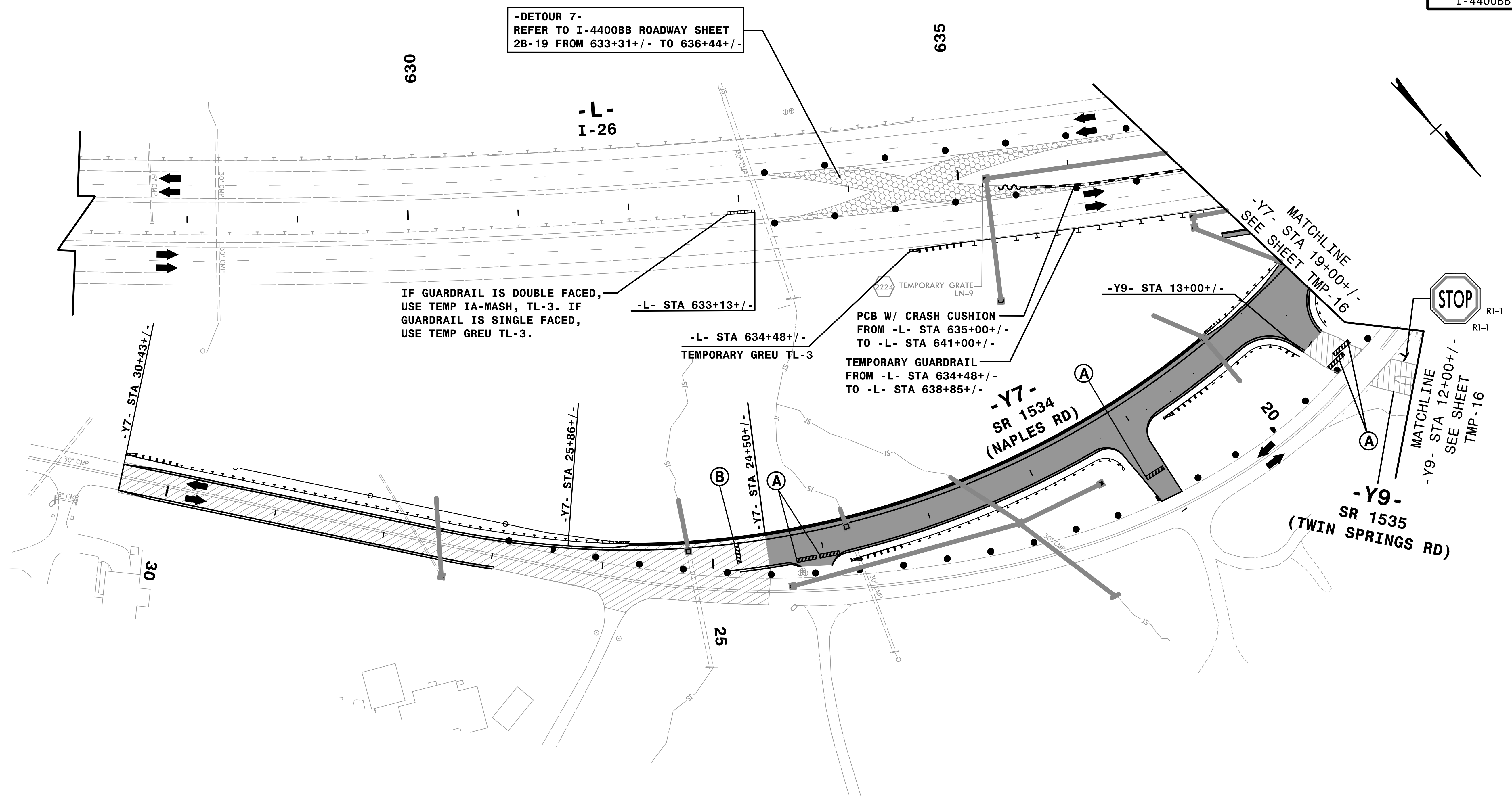

12:39:59 PM
I:\CPN\I-4400BB-1.c.pl\YTD02.dgn
9/3/2019

HNTB HNTB NORTH CAROLINA, P.C.
343 E. Six Forks Road, Suite 200
Raleigh, North Carolina 27609
NC License No: C-1554

APPROVED: *Rhonda B. Early*
F3MCAFSACBF48A
DATE: 9/3/2019

**DOCUMENT NOT CONSIDERED FINAL
UNLESS ALL SIGNATURES COMPLETED**



STEPS 4.1 THRU 4.4

TRANSPORTATION
MANAGEMENT PLAN

PHASE I
DETAIL

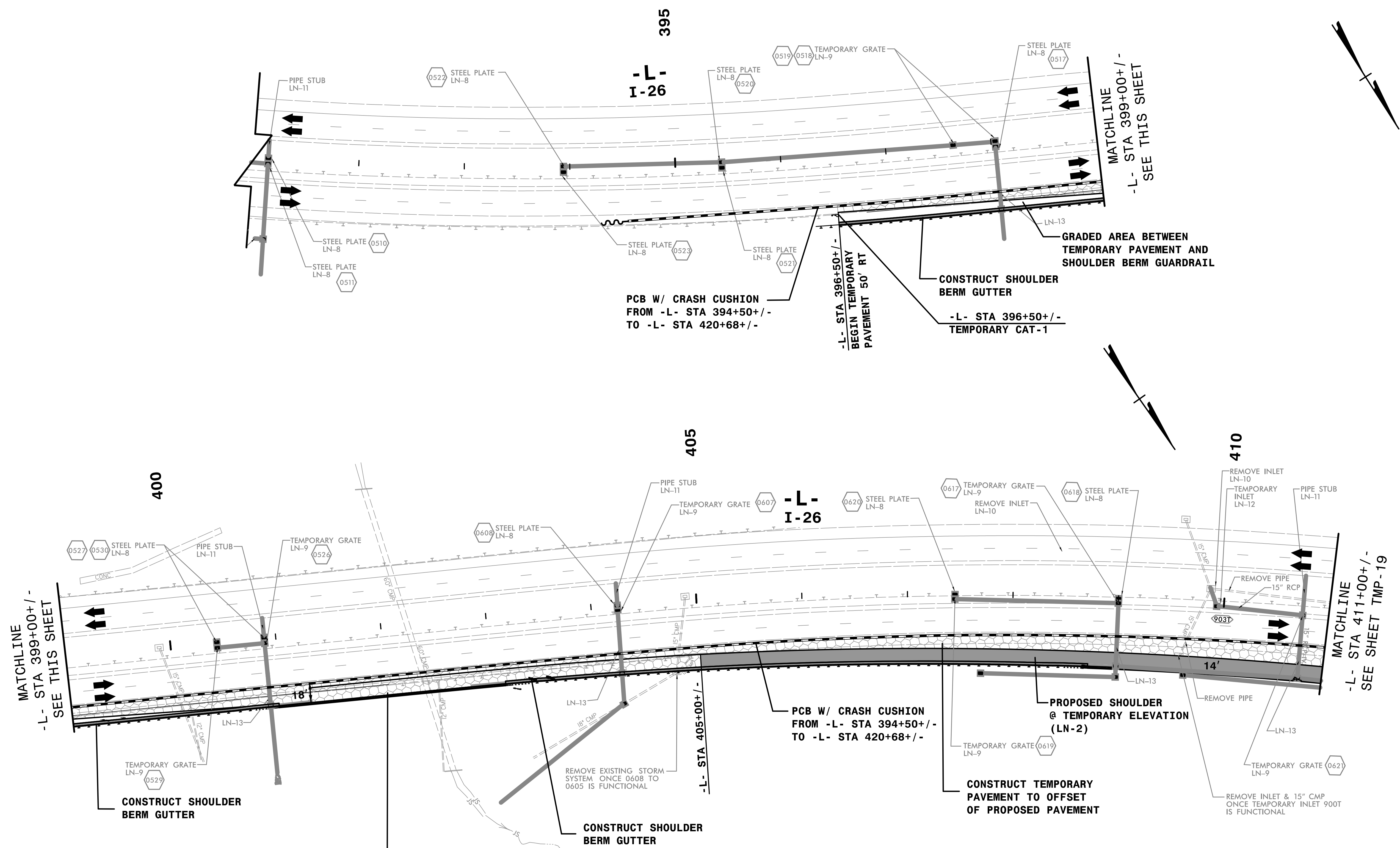

REFER TO SHEET TMP-5A FOR CUT SECTIONS.



APPROVED: *Rhonda B. Early*
 DATE: 9/3/2019

DocuSigned by:
 Rhonda B. Early
 F3MCAFSACBF48A...

9/3/2019

PROFESSIONAL ENGINEER
 NORTH CAROLINA
 SEAL
 023521
 RHONDA B. EARLY

DOCUMENT NOT CONSIDERED FINAL UNLESS ALL SIGNATURES COMPLETED



STEP 5.1 THRU 5.3

TRANSPORTATION MANAGEMENT PLAN

PHASE I
 DETAIL

12:40:09 PM
 I:\CP\1-4400BB-t.c.PID3.dgn
 9/3/2019

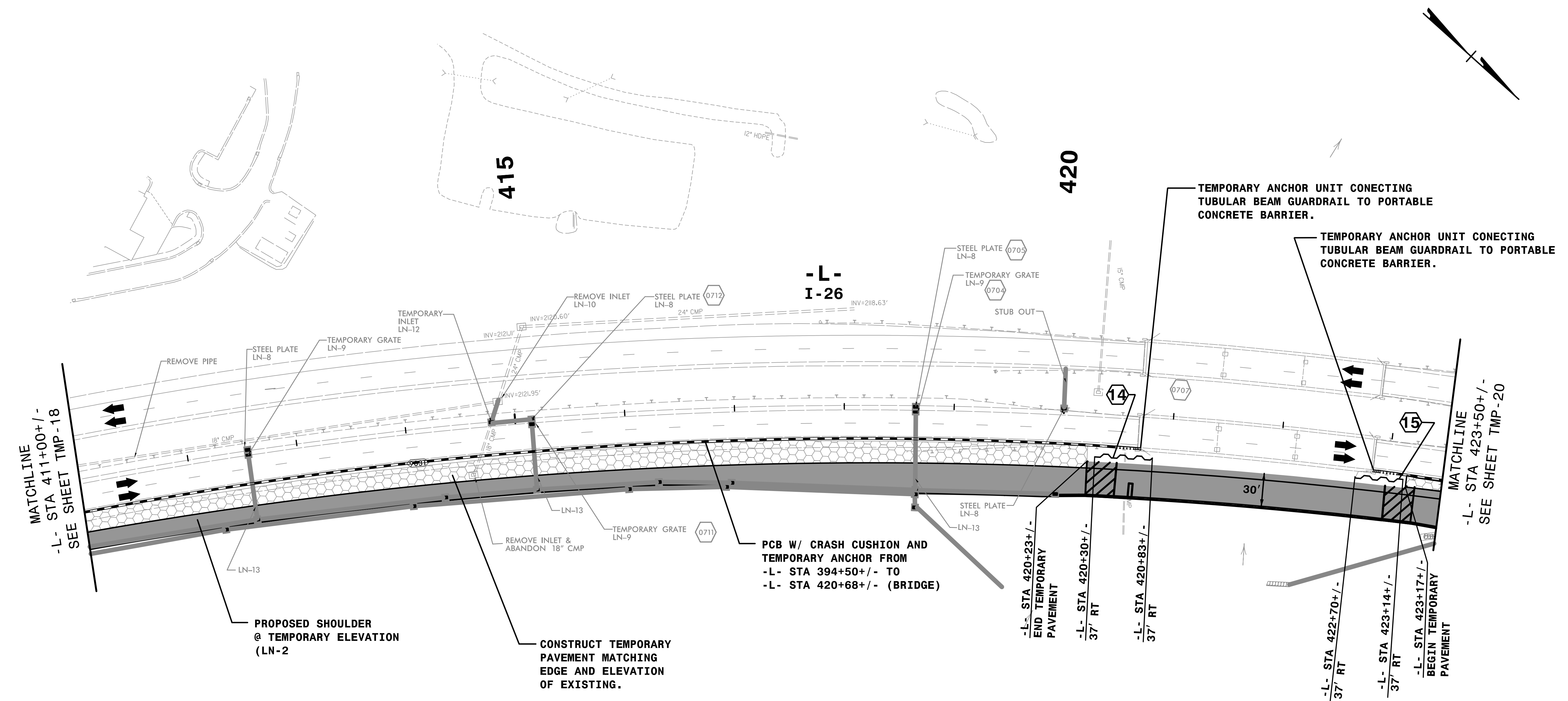

14 EST QUANTITY = 300 SF
 TEMPORARY SHORING
 FROM -L- STA 420+30+/-, 37' RT
 TO -L- STA 420+83+/-, 37' RT
 (SEE SHEET TMP-2A.2 FOR
 TEMPORARY SHORING NOTES)

15 EST QUANTITY = 220 SF
 TEMPORARY SHORING
 FROM -L- STA 422+70+/-, 37' RT
 TO -L- STA 423+14+/-, 37' RT
 (SEE SHEET TMP-2A.2 FOR
 TEMPORARY SHORING NOTES)

REFER TO SHEETS TMP-5A FOR CUT SECTIONS.



APPROVED: *Rhonda B. Early*
 DATE: 9/3/2019

Professional Engineer Seal: NORTH CAROLINA PROFESSIONAL ENGINEER SEAL 023521 RHONDA B. EARLY

DOCUMENT NOT CONSIDERED FINAL UNLESS ALL SIGNATURES COMPLETED

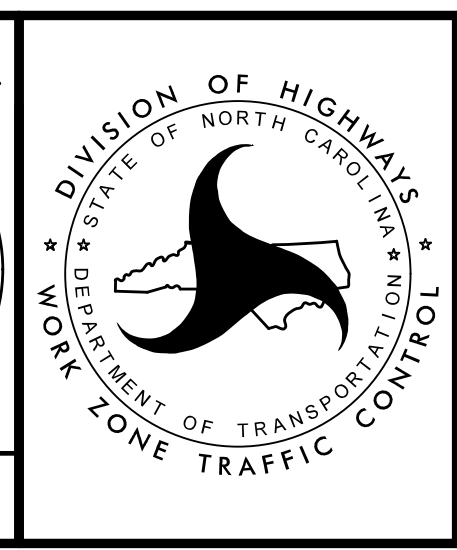

STEP 5.1 THRU 5.3

TRANSPORTATION MANAGEMENT PLAN

PHASE I DETAIL

12:40:17 PM
 I:\CP\I-4400BB.t.c.PID4.dgn
 9/3/2019

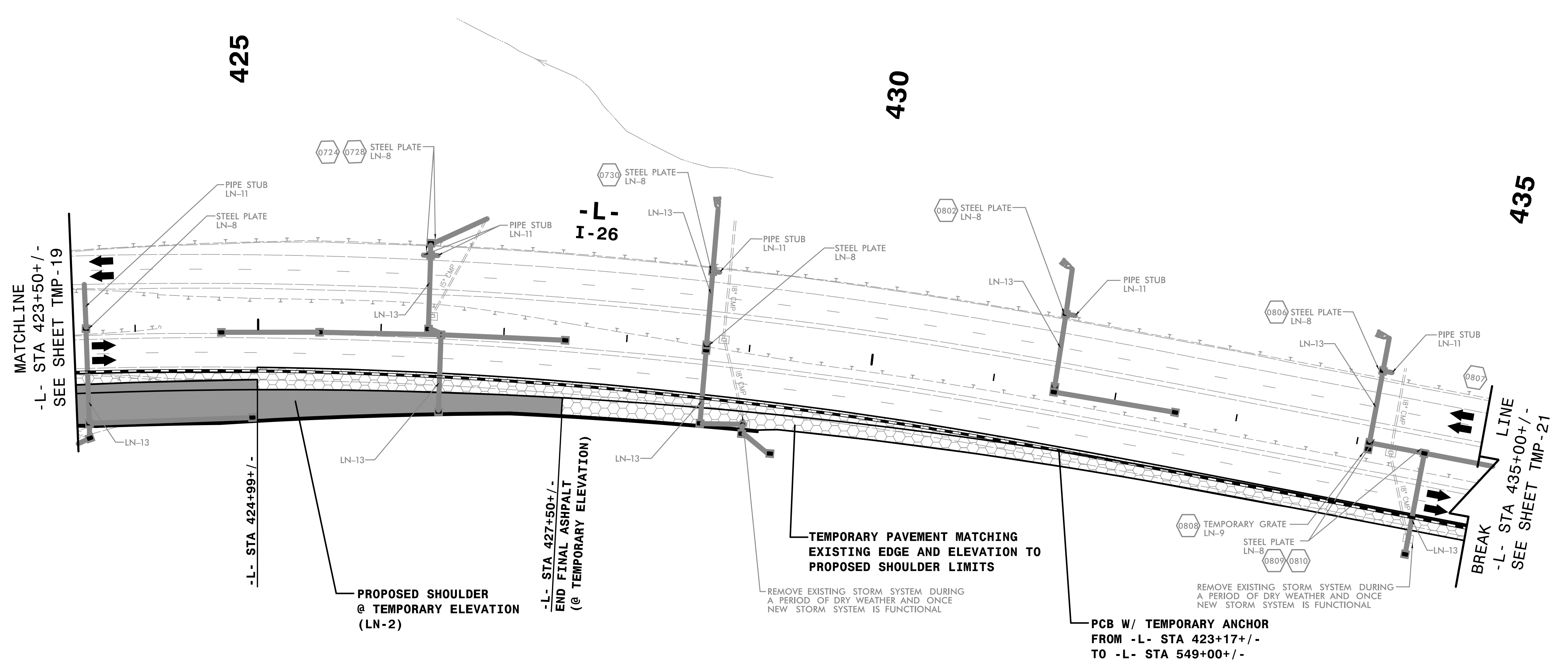
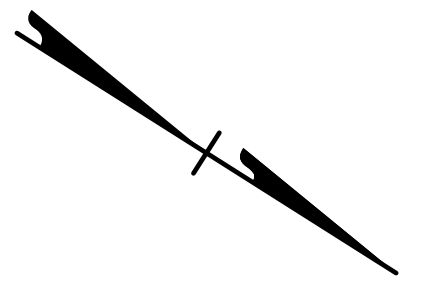

NOTE:
 SEE LN-9 FOR STRUCTURE NUMBERS BETWEEN STA 435+00 AND 545+00:
 0815, 0817, 0832, 0835, 0836, 0837, 0902, 0908, 0918, 0919, 0926,
 1012, 1002, 1007, 1010, 1106, 1107, 1110, 1111, 1114, 1115, 1119,
 1201, 1202, 1208, 1209, 1211, 1215, 1216, 1222, 1223, 1312, 1311,
 1313, 1318, 1322, 1323, 1403, 1404, 1405, 1411, 1412, 1413, 1420
 1421, 1422, 1423, 1424, 1425, 1432, 1504, 1507, 1508, 1511, 1513,
 1516, 1603, 1604, 1614

SEE LN-8 FOR STRUCTURE NUMBERS BETWEEN STA 435+00 AND 545+00:
 0816, 0814, 0834, 0831, 0903, 0909, 0913, 0914, 0917, 0929, 1004,
 0925, 0928, 1003, 1009, 1006, 1105, 1014, 1118, 1207, 1212, 1213,
 1217, 1218, 1224, 1302, 1303, 1304, 1310, 1316, 1317, 1402, 1410,
 1409, 1419, 1431, 1502, 1503, 1518, 1506, 1510, 1512, 1515, 1602,
 1612, 1613

REMOVE CONFLICTING PAVEMENT MARKING.
 REFER TO SHEET TMP-5A FOR CUT SECTIONS.

STEP 5.1 THRU 5.3

TRANSPORTATION
 MANAGEMENT PLAN

PHASE I
 DETAIL

APPROVED: *Rhonda B. Early*
 DATE: 9/3/2019

DocuSigned by:
 Rhonda B. Early
 F34CAF5AC8BF48A...

PROFESSIONAL ENGINEER
 NORTH CAROLINA
 SEAL
 023521
 RHONDA B. EARLY

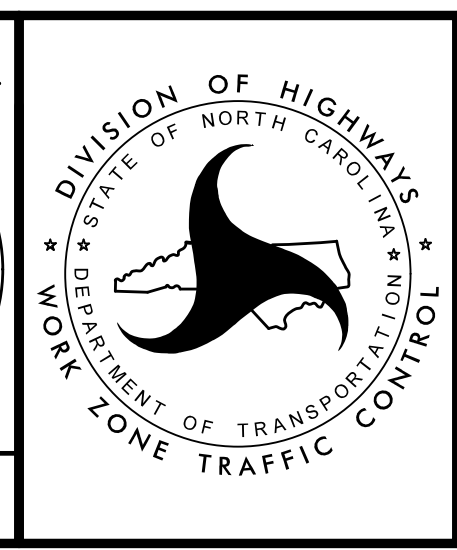

HNTB HNTB NORTH CAROLINA, P.C.
 343 E. Six Forks Road, Suite 200
 Raleigh, North Carolina 27609
 NC License No: C-1554

**DOCUMENT NOT CONSIDERED FINAL
 UNLESS ALL SIGNATURES COMPLETED**

12:40:26 PM
 I:\CPN\I-4400BB.tcd.PID5.dgn
 9/3/2019

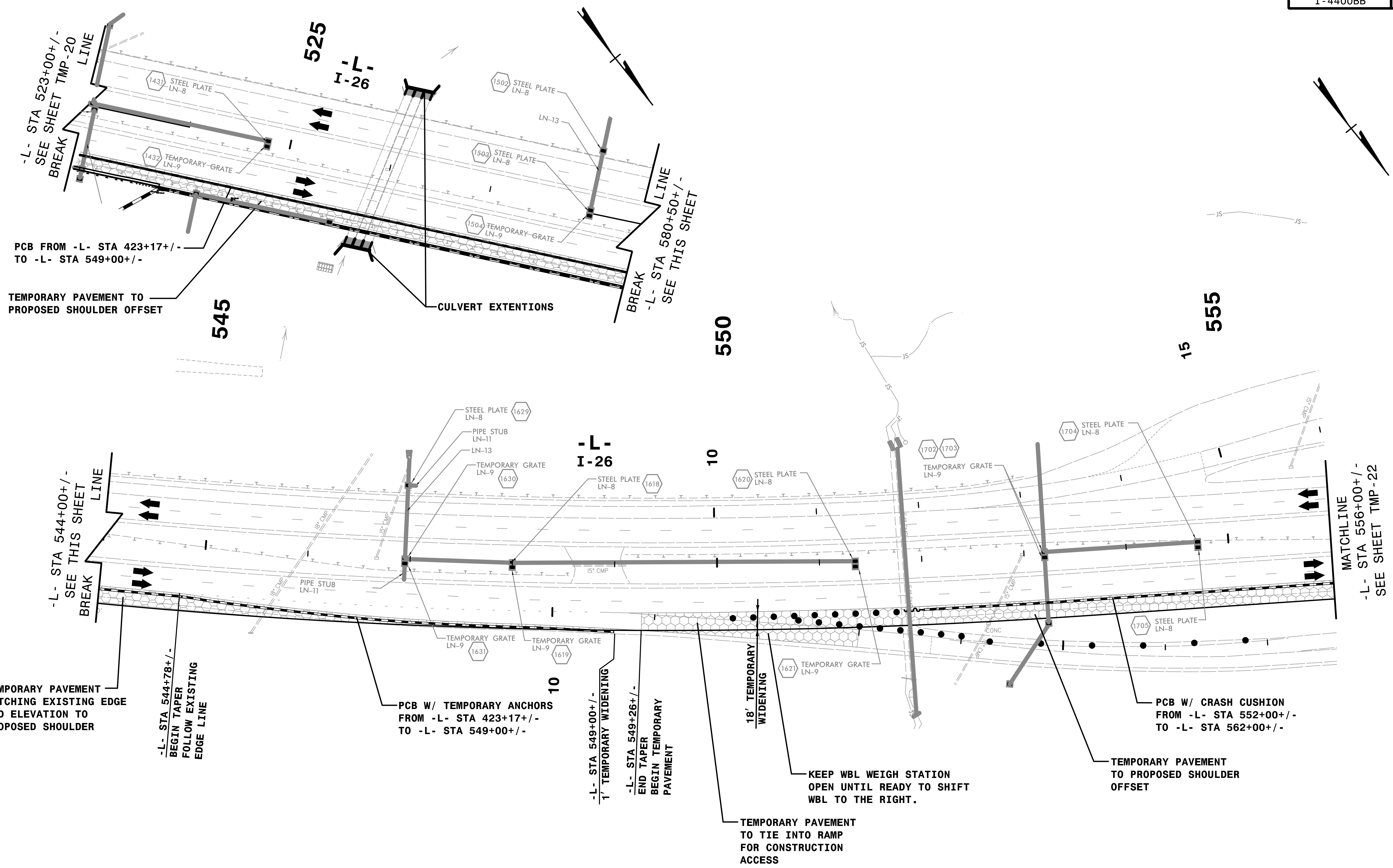

TEMPORARY PAVEMENT MATCHING EXISTING EDGE AND ELEVATION TO PROPOSED SHOULDER

-L- STA 544+78+/- BEGIN TAPER FOLLOW EXISTING EDGE LINE

PCB W/ TEMPORARY ANCHORS FROM -L- STA 423+17+/- TO -L- STA 549+00+/-

-L- STA 549+00+/- 1' TEMPORARY WIDENING

-L- STA 549+26+/- END TAPER BEGIN TEMPORARY PAVEMENT

TEMPORARY PAVEMENT TO TIE INTO RAMP FOR CONSTRUCTION ACCESS

KEEP WBL WEIGH STATION OPEN UNTIL READY TO SHIFT WBL TO THE RIGHT.

TEMPORARY PAVEMENT TO PROPOSED SHOULDER OFFSET

PCB W/ CRASH CUSHION FROM -L- STA 552+00+/- TO -L- STA 562+00+/-

MATCHLINE -L- STA 556+00+/- SEE SHEET TMP-22

REFER TO SHEET TMP-5B FOR CUT SECTIONS.

STEP 5.1 THRU 5.4

TRANSPORTATION MANAGEMENT PLAN

PHASE I
DETAIL

12:40:34 PM
I:\CPN\I-4400BB-t.c.PID\5.dgn
9/3/2019

HNTB HNTB NORTH CAROLINA, P.C.
343 E. Six Forks Road, Suite 200
Raleigh, North Carolina 27609
NC License No: C-1554

APPROVED: *Rhonda B. Early*
DATE: 9/3/2019

NORTH CAROLINA
PROFESSIONAL
ENGINEER
SEAL
023521
RHONDA B. EARLY

DOCUMENT NOT CONSIDERED FINAL
UNLESS ALL SIGNATURES COMPLETED

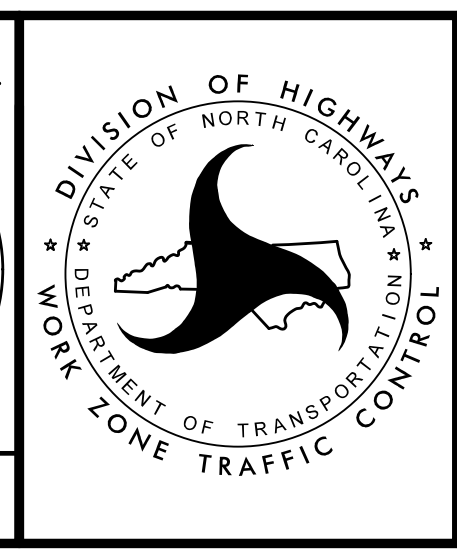

TRANSPORTATION MANAGEMENT PLAN

PHASE I
DETAIL

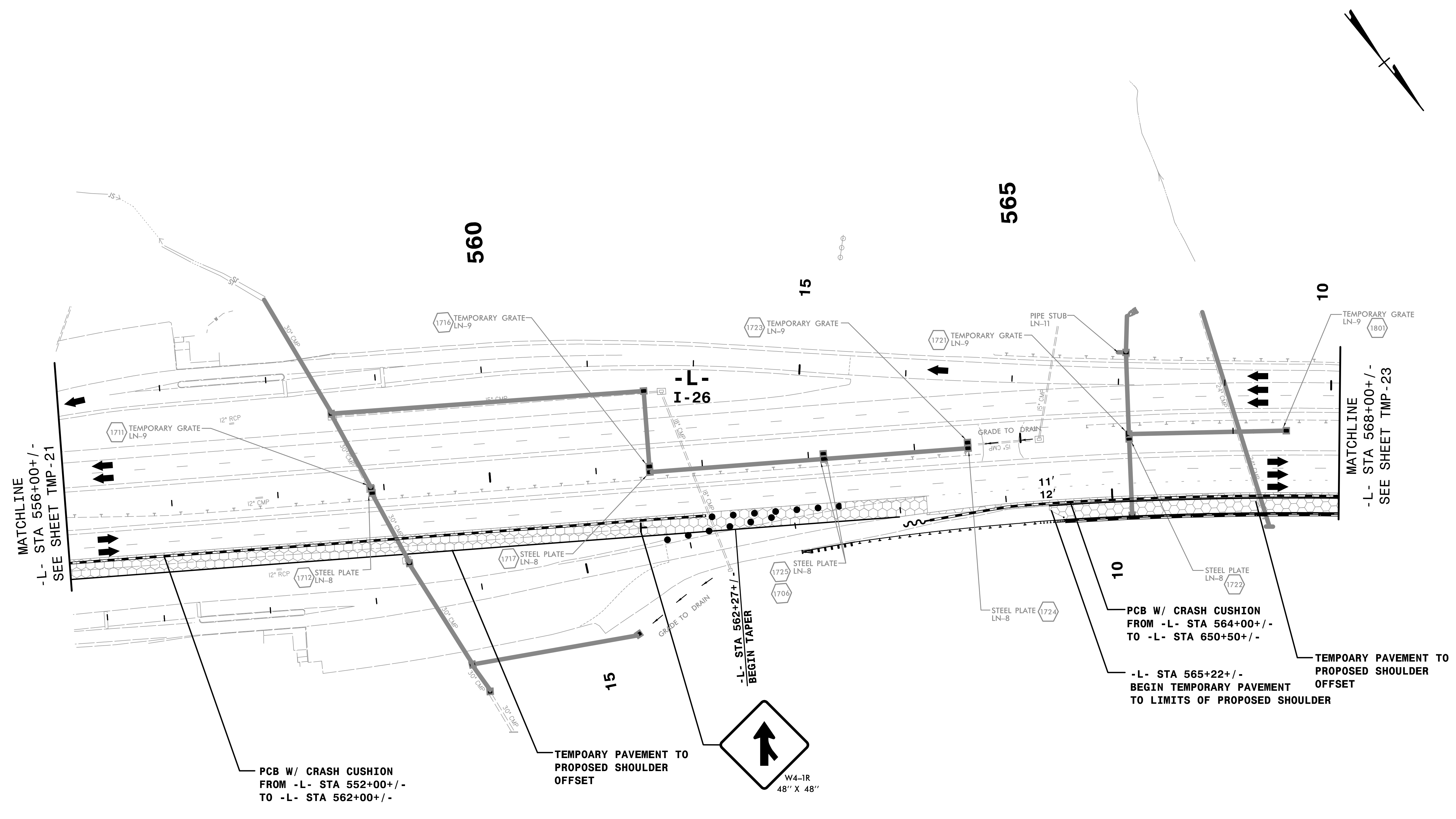

MATCHLINE
-L- STA 556+00+/-
SEE SHEET TMP-21

MATCHLINE
-L- STA 568+00+/-
SEE SHEET TMP-23

PCB W/ CRASH CUSHION
FROM -L- STA 552+00+/-
TO -L- STA 562+00+/-

TEMPOARY PAVEMENT TO
PROPOSED SHOULDER
OFFSET

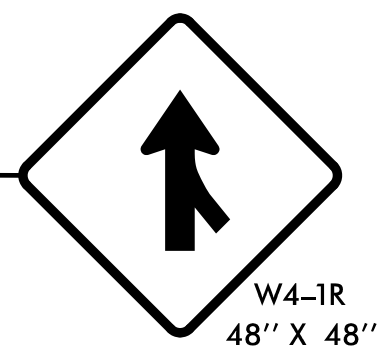

PCB W/ CRASH CUSHION
FROM -L- STA 564+00+/-
TO -L- STA 650+50+/-

-L- STA 565+22+/-
BEGIN TEMPORARY PAVEMENT
TO LIMITS OF PROPOSED SHOULDER

TEMPOARY PAVEMENT TO
PROPOSED SHOULDER
OFFSET

12:40:42 PM
I:\CP\I-4400BB.t.c.PIDIG.dgn
9/3/2019

REFER TO SHEET TMP-5B FOR CUT SECTIONS.

HNTB HNTB NORTH CAROLINA, P.C.
343 E. Six Forks Road, Suite 200
Raleigh, North Carolina 27609
NC License No: C-1554

APPROVED: *Rhonda B. Early*
DATE: 9/3/2019

DocuSigned by:
Rhonda B. Early
F34CAF5AC8BF48A...

SEAL
023521
NORTH CAROLINA
PROFESSIONAL
ENGINEERS
RHONDA B. EARLY

**DOCUMENT NOT CONSIDERED FINAL
UNLESS ALL SIGNATURES COMPLETED**

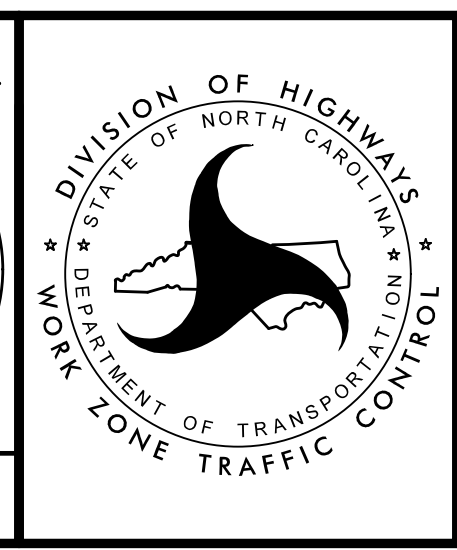

STEP 5.1 THRU 5.4

TRANSPORTATION
MANAGEMENT PLAN

PHASE I
DETAIL

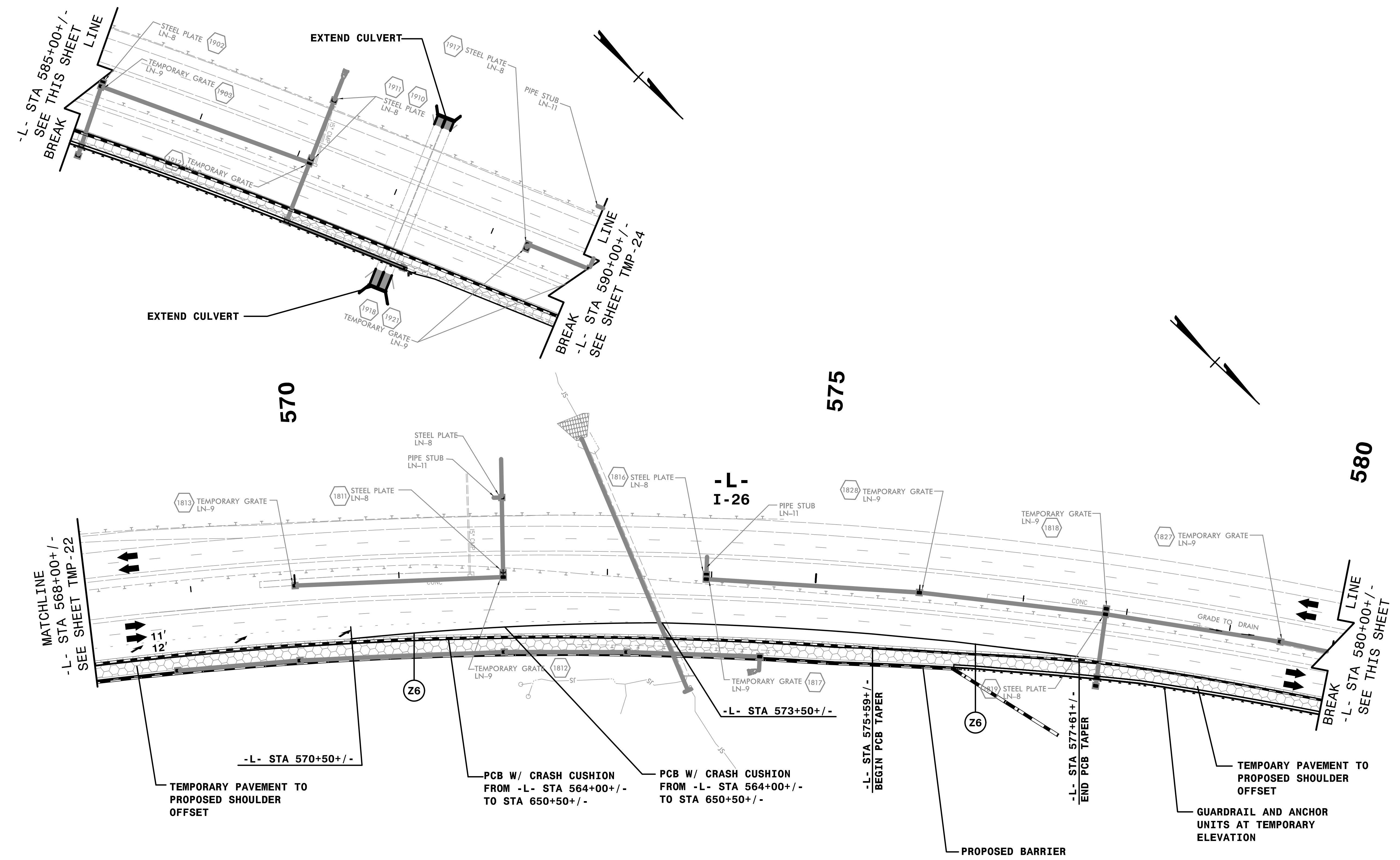

REFER TO SHEETS TMP-5B FOR CUT SECTIONS.



APPROVED: *Rhonda B. Early*
 DATE: 9/3/2019

DocuSigned by:
 Rhonda B. Early
 F34CAFACBF48A...

SEAL
 023521
 NORTH CAROLINA
 PROFESSIONAL
 ENGINEERS
 RHONDA B. EARLY

**DOCUMENT NOT CONSIDERED FINAL
 UNLESS ALL SIGNATURES COMPLETED**

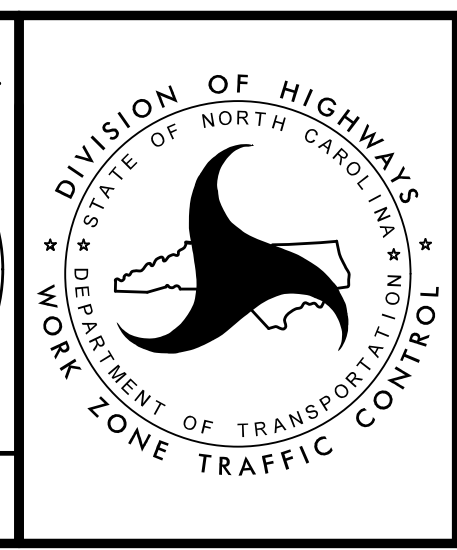

STEP 5.1 THRU 5.4

TRANSPORTATION
 MANAGEMENT PLAN

PHASE I
 DETAIL

12:40:50 PM
 I:\CP\I-4400BB.t.c. P1D17.dgn
 9/3/2019

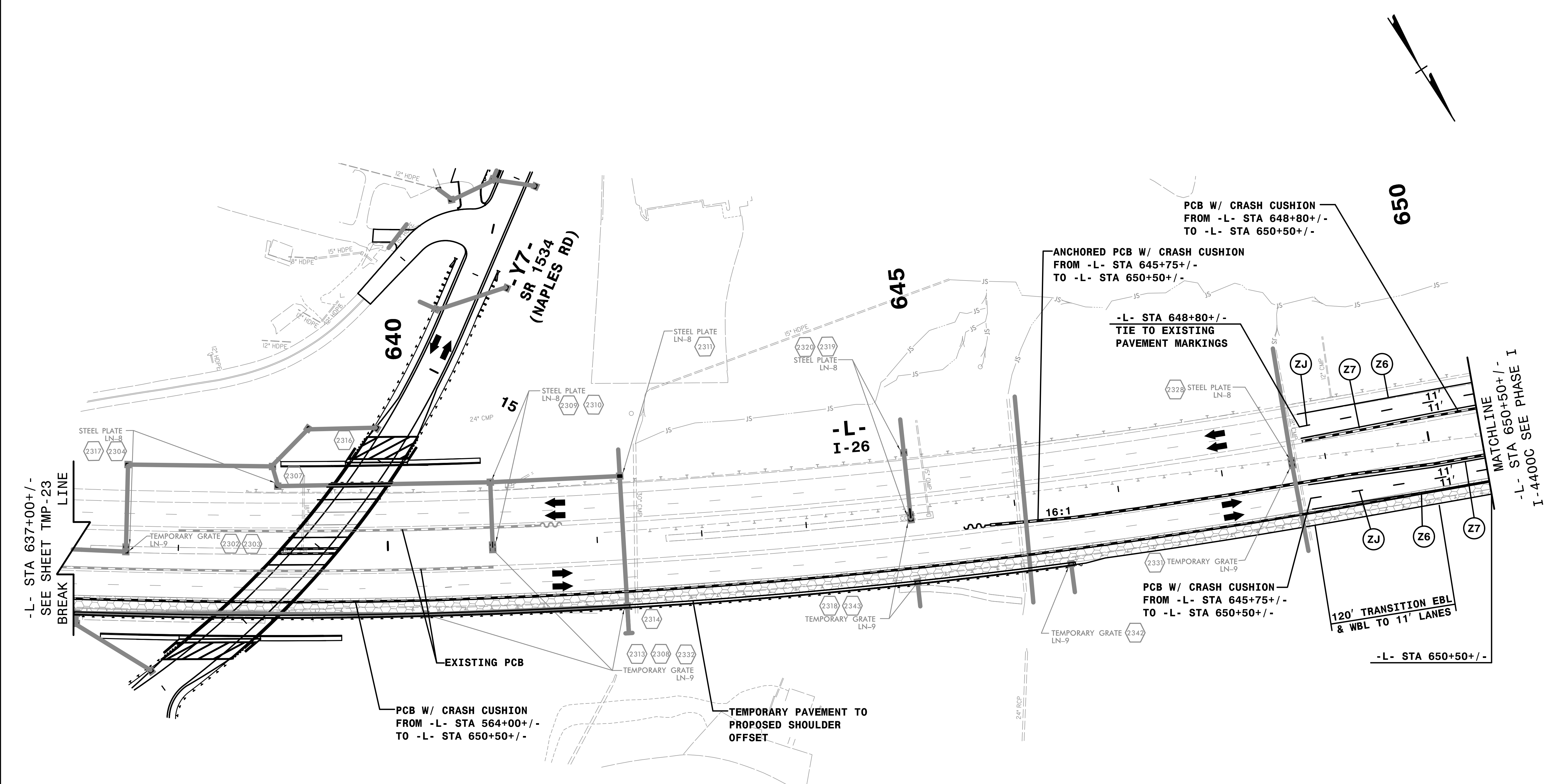

**STEP 5.1 THRU 5.4
& STEP 5.5**

TRANSPORTATION
MANAGEMENT PLAN

PHASE I
DETAIL

APPROVED: *Rhonda B. Early*
DocuSigned by:
Rhonda B. Early
F34CAF5AC8BF48A...

DATE: 9/3/2019

SEAL
 NORTH CAROLINA
 PROFESSIONAL ENGINEER
 023521
 RHONDA B. EARLY

**DOCUMENT NOT CONSIDERED FINAL
UNLESS ALL SIGNATURES COMPLETED**

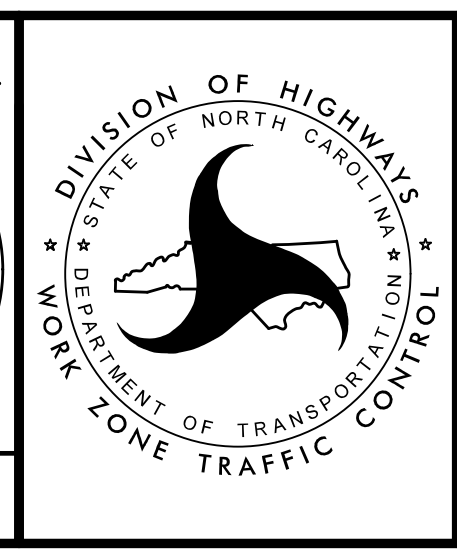

HNTB HNTB NORTH CAROLINA, P.C.
 343 E. Six Forks Road, Suite 200
 Raleigh, North Carolina 27609
 NC License No: C-1554

REFER TO SHEET TMP-5C FOR CUT SECTIONS.

9/3/2019
 ICPN-4400BB.t.c.PID23.dgn
 \$\$\$DATE\$\$\$

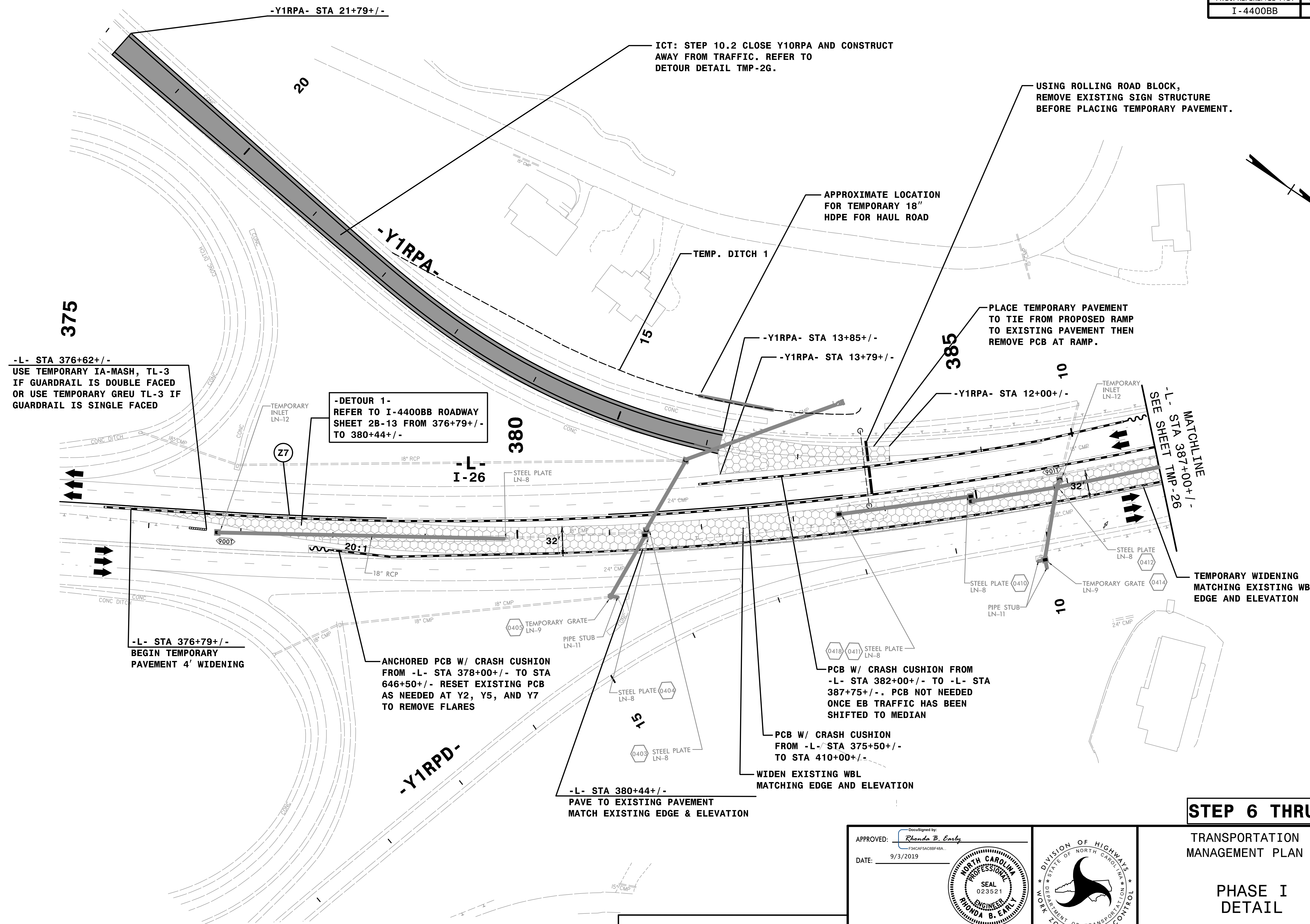

-L- STA 376+62+/-
 USE TEMPORARY IA-MASH, TL-3
 IF GUARDRAIL IS DOUBLE FACED
 OR USE TEMPORARY GREU TL-3 IF
 GUARDRAIL IS SINGLE FACED

-DETOUR 1-
 REFER TO I-4400BB ROADWAY
 SHEET 2B-13 FROM 376+79+/-
 TO 380+44+/-

-L- STA 376+79+/-
 BEGIN TEMPORARY
 PAVEMENT 4' WIDENING

ANCHORED PCB W/ CRASH CUSHION
 FROM -L- STA 378+00+/- TO STA
 646+50+/- RESET EXISTING PCB
 AS NEEDED AT Y2, Y5, AND Y7
 TO REMOVE FLARES

-L- STA 380+44+/-
 PAVE TO EXISTING PAVEMENT
 MATCH EXISTING EDGE & ELEVATION

PCB W/ CRASH CUSHION FROM
 -L- STA 382+00+/- TO -L- STA
 387+75+/- PCB NOT NEEDED
 ONCE EB TRAFFIC HAS BEEN
 SHIFTED TO MEDIAN

PCB W/ CRASH CUSHION
 FROM -L- STA 375+50+/-
 TO STA 410+00+/-
 WIDEN EXISTING WBL
 MATCHING EDGE AND ELEVATION

PLACE TEMPORARY PAVEMENT
 TO TIE FROM PROPOSED RAMP
 TO EXISTING PAVEMENT THEN
 REMOVE PCB AT RAMP.

TEMPORARY WIDENING
 MATCHING EXISTING WB
 EDGE AND ELEVATION

ICT: STEP 10.2 CLOSE Y10RPA AND CONSTRUCT
 AWAY FROM TRAFFIC. REFER TO
 DETOUR DETAIL TMP-2G.

USING ROLLING ROAD BLOCK,
 REMOVE EXISTING SIGN STRUCTURE
 BEFORE PLACING TEMPORARY PAVEMENT.

REFER TO SHEET TMP-5C FOR CUT SECTIONS.

STEP 6 THRU 10

TRANSPORTATION
 MANAGEMENT PLAN

PHASE I
 DETAIL

12:41:05 PM
 I:\CP\I-4400BB.tc.Plan.dgn
 9/3/2019

HNTB
 HNTB NORTH CAROLINA, P.C.
 343 E. Six Forks Road, Suite 200
 Raleigh, North Carolina 27609
 NC License No: C-1554

APPROVED: *Rhonda B. Early*
 DATE: 9/3/2019

DocuSigned by:
 Rhonda B. Early
 F34CAF5AC8BF48A...

PROFESSIONAL ENGINEER
 NORTH CAROLINA
 SEAL
 023521
 RHONDA B. EARLY

DIVISION OF HIGHWAYS
 STATE OF NORTH CAROLINA
 DEPARTMENT OF TRANSPORTATION
 WORK ZONE TRAFFIC CONTROL

DOCUMENT NOT CONSIDERED FINAL
 UNLESS ALL SIGNATURES COMPLETED

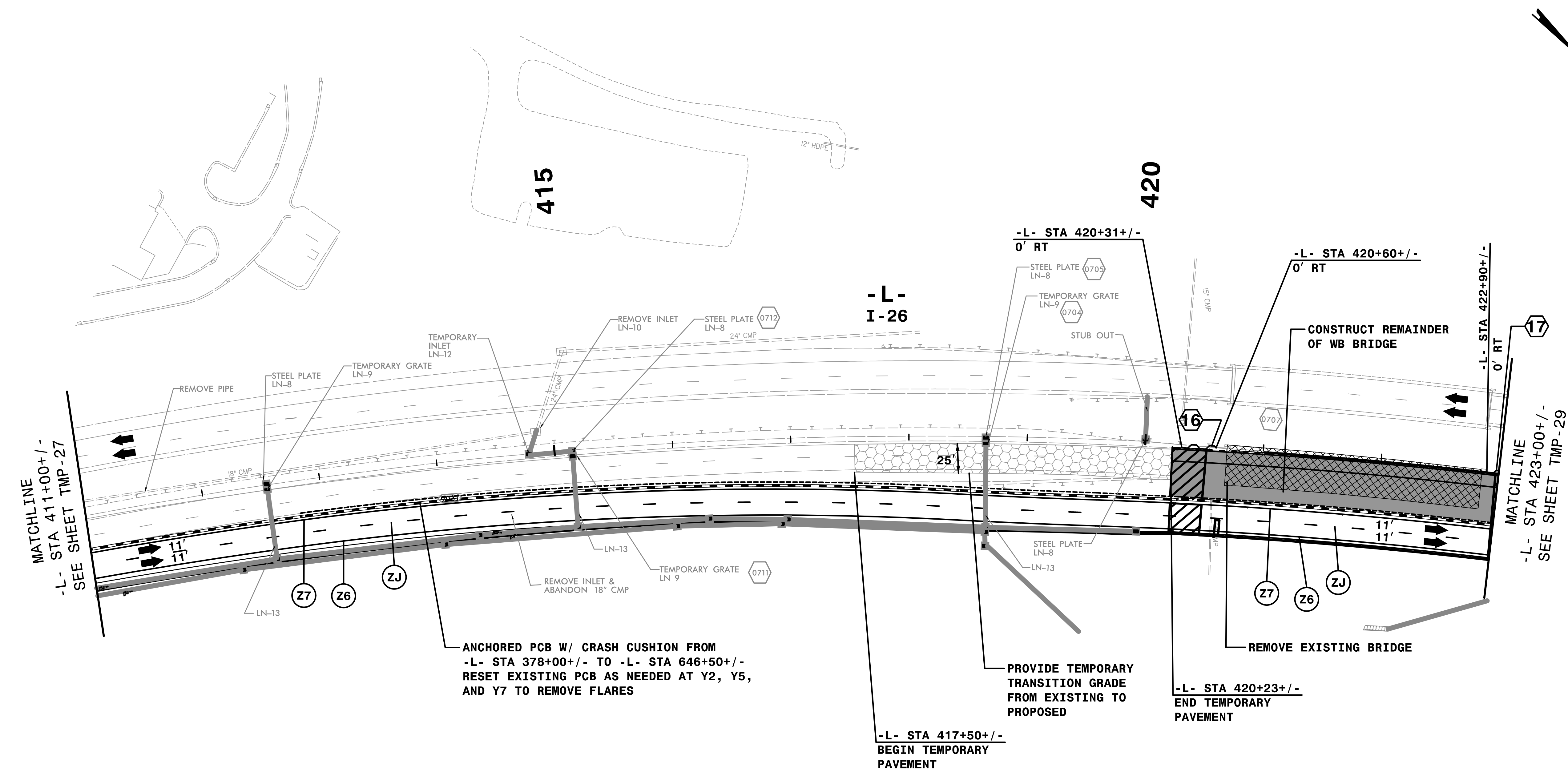

16 EST QUANTITY = 130 SF
 TEMPORARY SHORING
 FROM -L- STA 420+31+/-, 0' RT
 TO -L- STA 420+60+/-, 0' RT
 (SEE SHEET TMP-2A.2 FOR
 TEMPORARY SHORING NOTES)

17 EST QUANTITY = 150 SF
 TEMPORARY SHORING
 FROM -L- STA 422+90+/-, 0' RT
 TO -L- STA 423+20+/-, 0' RT
 (SEE SHEET TMP-2A.2 FOR
 TEMPORARY SHORING NOTES)

REFER TO SHEETS TMP-5C FOR CUT SECTIONS.

STEPS 6 THRU 10

APPROVED: *Rhonda B. Early*
 DATE: 9/3/2019

NORTH CAROLINA
 PROFESSIONAL ENGINEER
 SEAL 023521
 RHONDA B. EARLY

**DOCUMENT NOT CONSIDERED FINAL
 UNLESS ALL SIGNATURES COMPLETED**

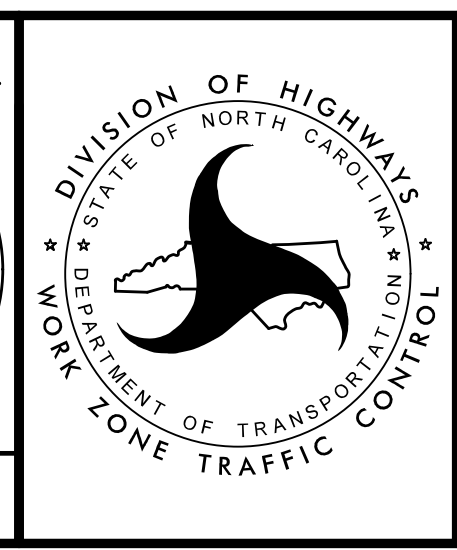

TRANSPORTATION
 MANAGEMENT PLAN

PHASE I
 DETAIL

HNTB HNTB NORTH CAROLINA, P.C.
 343 E. Six Forks Road, Suite 200
 Raleigh, North Carolina 27609
 NC License No: C-1554

12:41:28 PM
 I:\CP\I-4400BB.t.c. Plad4.dgn
 9/3/2019

NOTE:
 WHEN PLACING THE PROPOSED PCB ALONG THE WB MEDIAN, REMOVE EXISTING CRASH CUSHION, SHIFT AND ANCHOR THE EXISTING WB MEDIAN PCB (APPROXIMATELY 1' RT) IN THE FOLLOWING LOCATIONS:
 *FROM STA 435+40+/- TO STA 441+00+/- (PLACED FOR -Y2- BRIDGE CONSTRUCTION)
 *FROM STA 537+35+/- TO STA 542+00+/- (PLACED FOR -Y5- BRIDGE CONSTRUCTION)
 *FROM STA 635+00+/- TO STA 641+00+/- (NO SHIFT REQUIRED- PLACED FOR -Y7- BRIDGE CONSTRUCTION)

WHEN PLACING THE PROPOSED PCB ALONG THE EB MEDIAN, REMOVE EXISTING CRASH CUSHION AND TIE PROPOSED PCB TO EXISTING PCB IN THE FOLLOWING LOCATIONS:
 *FROM STA 438+00+/- TO STA 441+00+/- (PLACED FOR -Y2- BRIDGE CONSTRUCTION)
 *FROM STA 539+00+/- TO STA 543+10+/- (PLACED FOR -Y5- BRIDGE CONSTRUCTION)
 *FROM STA 638+00+/- TO STA 641+40+/- (PLACED FOR -Y7- BRIDGE CONSTRUCTION)

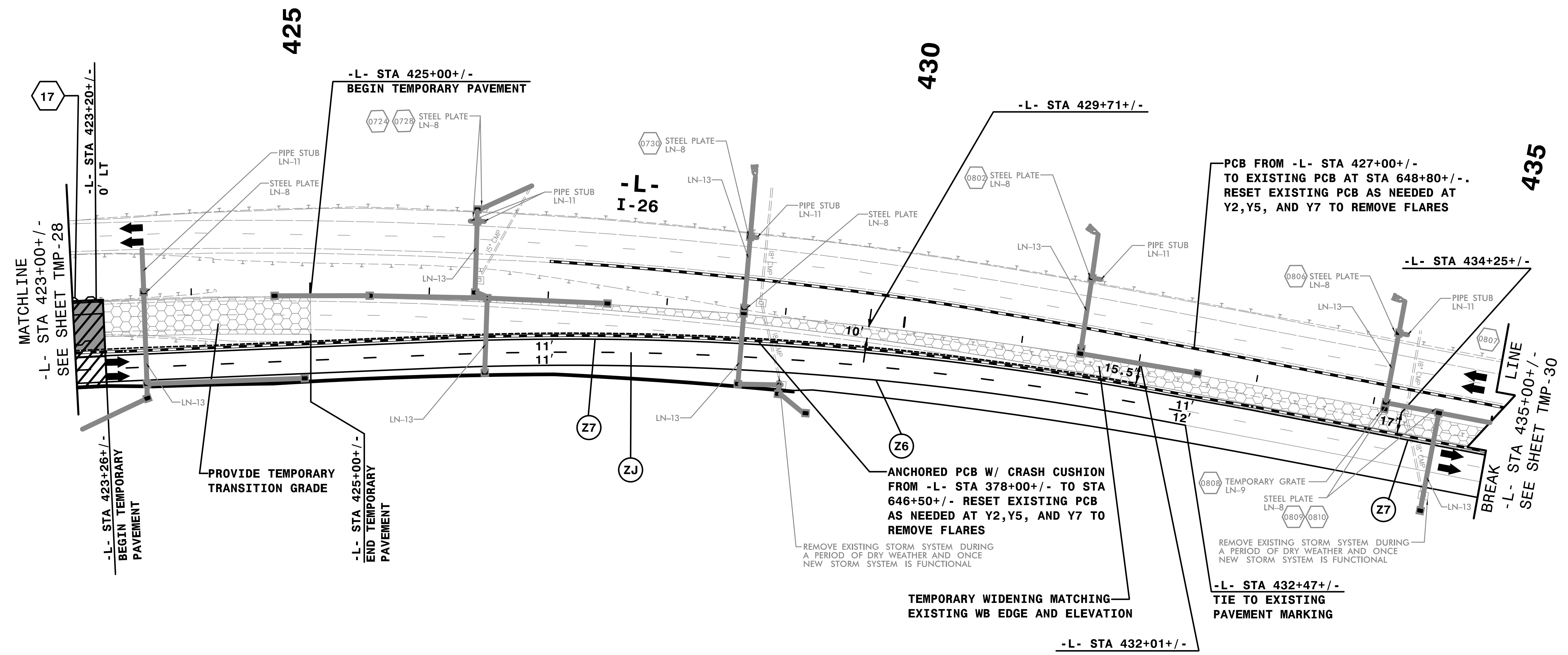
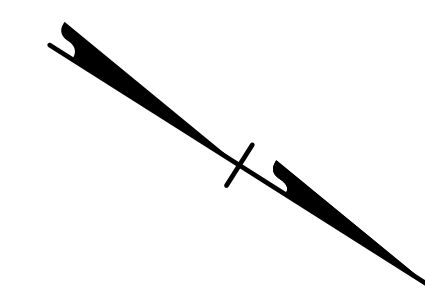

17 EST QUANTITY = 150 SF

TEMPORARY SHORING
 FROM -L- STA 422+90+/-, 0' RT
 TO -L- STA 423+20+/-, 0' RT

(SEE SHEET TMP-2A.2 FOR
 TEMPORARY SHORING NOTES)

- REMOVE CONFLICTING PAVEMENT MARKING.
- REFER TO SHEET TMP-5C FOR CUT SECTIONS.

STEPS 6 THRU 10

TRANSPORTATION
 MANAGEMENT PLAN

PHASE I
 DETAIL

APPROVED: *Rhonda B. Early*
 DATE: 9/3/2019

DocuSigned by:
 Rhonda B. Early
 F34CAF5AC8BF48A...

SEAL
 023521
 NORTH CAROLINA
 PROFESSIONAL
 ENGINEER
 RHONDA B. EARLY

DOCUMENT NOT CONSIDERED FINAL
 UNLESS ALL SIGNATURES COMPLETED

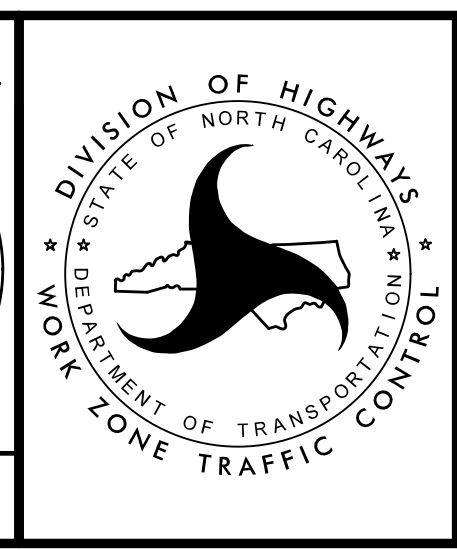

HNTB
 HNTB NORTH CAROLINA, P.C.
 343 E. Six Forks Road, Suite 200
 Raleigh, North Carolina 27609
 NC License No: C-1554

12:41:35 PM
 \\TCPL\1-4400BB-t.c. Plad5.dgn
 9/3/2019

NOTE:

WHEN PLACING THE PROPOSED PCB ALONG THE WB MEDIAN, REMOVE EXISTING CRASH CUSHION, SHIFT AND ANCHOR THE EXISTING WB MEDIAN PCB (APPROXIMATELY 1' RT) IN THE FOLLOWING LOCATIONS:

- * FROM STA 435+40+/- TO STA 441+00+/- (PLACED FOR -Y2- BRIDGE CONSTRUCTION)
- * FROM STA 537+35+/- TO STA 542+00+/- (PLACED FOR -Y5- BRIDGE CONSTRUCTION)
- * FROM STA 635+00+/- TO STA 641+00+/- (NO SHIFT REQUIRED- PLACED FOR -Y7- BRIDGE CONSTRUCTION)

WHEN PLACING THE PROPOSED PCB ALONG THE EB MEDIAN, REMOVE EXISTING CRASH CUSHION AND TIE PROPOSED PCB TO EXISTING PCB IN THE FOLLOWING LOCATIONS:

- *FROM STA 438+00+/- TO STA 441+00+/- (PLACED FOR -Y2- BRIDGE CONSTRUCTION)
- *FROM STA 539+00+/- TO STA 543+10+/- (PLACED FOR -Y5- BRIDGE CONSTRUCTION)
- *FROM STA 638+00+/- TO STA 641+40+/- (PLACED FOR -Y7- BRIDGE CONSTRUCTION)

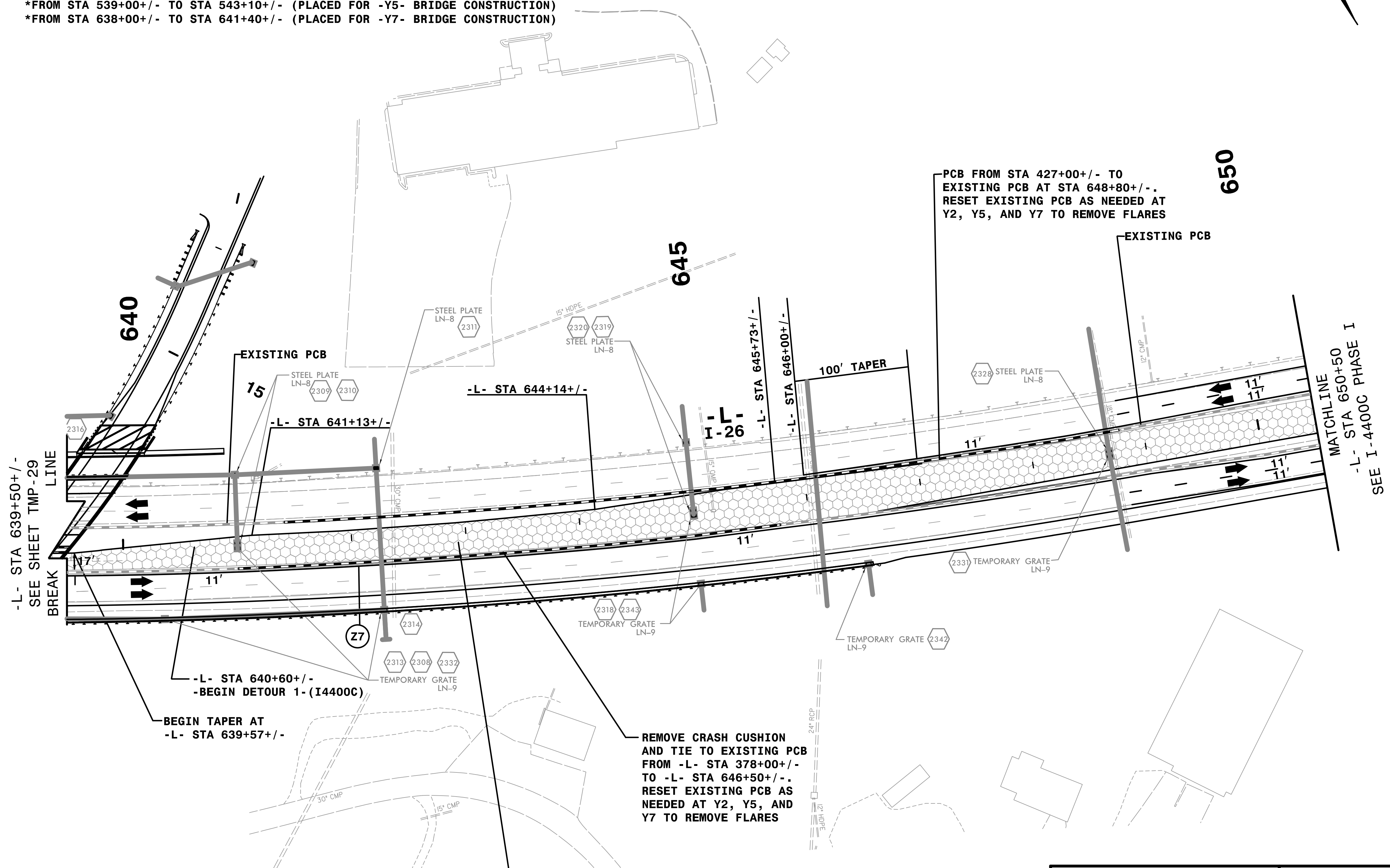

-L- STA 639+50+/-
SEE SHEET TMP-29
BREAK
LINE

-L- STA 640+60+/-
-BEGIN DETOUR 1- (I4400C)
-BEGIN TAPER AT
-L- STA 639+57+/-

REMOVE CRASH CUSHION AND TIE TO EXISTING PCB FROM -L- STA 378+00+/- TO -L- STA 646+50+/- . RESET EXISTING PCB AS NEEDED AT Y2, Y5, AND Y7 TO REMOVE FLARES

PCB FROM STA 427+00+/- TO EXISTING PCB AT STA 648+80+/- . RESET EXISTING PCB AS NEEDED AT Y2, Y5, AND Y7 TO REMOVE FLARES

-DETOUR 1- (I4400C)
REFER TO I-4400C ROADWAY SHEETS 2B-13 THRU 2B-17 FOR TEMPORARY PAVEMENT FROM -L- STA 640+60+/- (I-4400BB) TO -L- STA 702+00+/- (I-4400C)

REFER TO SHEETS TMP-5D FOR CUT SECTIONS.
REMOVE CONFLICTING PAVEMENT MARKING.



APPROVED: *Rhonda B. Early*
DATE: 9/3/2019

DOCUMENT NOT CONSIDERED FINAL UNLESS ALL SIGNATURES COMPLETED

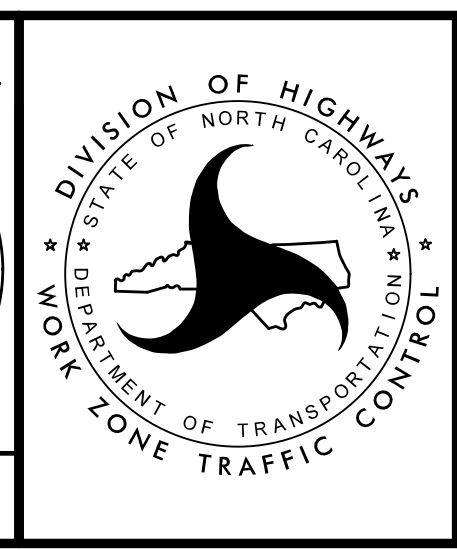

STEPS 6 THRU 10

TRANSPORTATION MANAGEMENT PLAN

PHASE I
DETAIL

12:41:46 PM
I:\CP\I-4400BB-t.c.pld23.dgn
9/3/2019

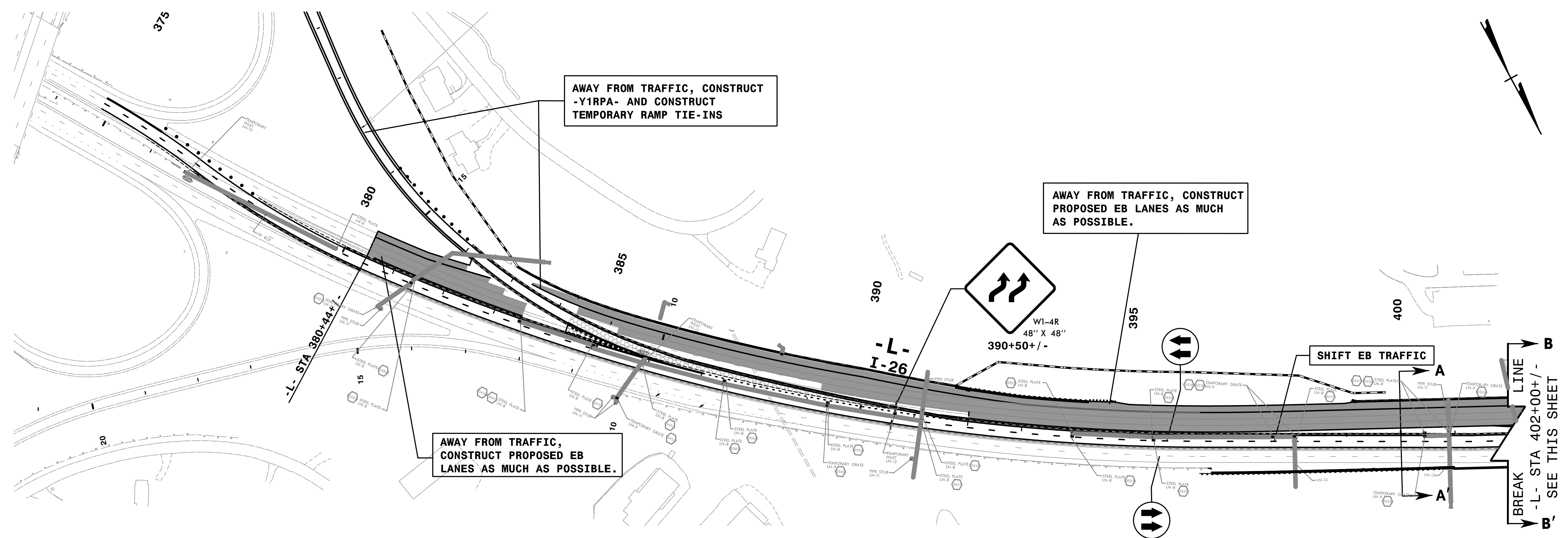

AWAY FROM TRAFFIC, CONSTRUCT -Y1RPA- AND CONSTRUCT TEMPORARY RAMP TIE-INS

AWAY FROM TRAFFIC, CONSTRUCT PROPOSED EB LANES AS MUCH AS POSSIBLE.

AWAY FROM TRAFFIC, CONSTRUCT PROPOSED EB LANES AS MUCH AS POSSIBLE.

SHIFT EB TRAFFIC

BREAK -L- STA 402+00+/- SEE THIS SHEET

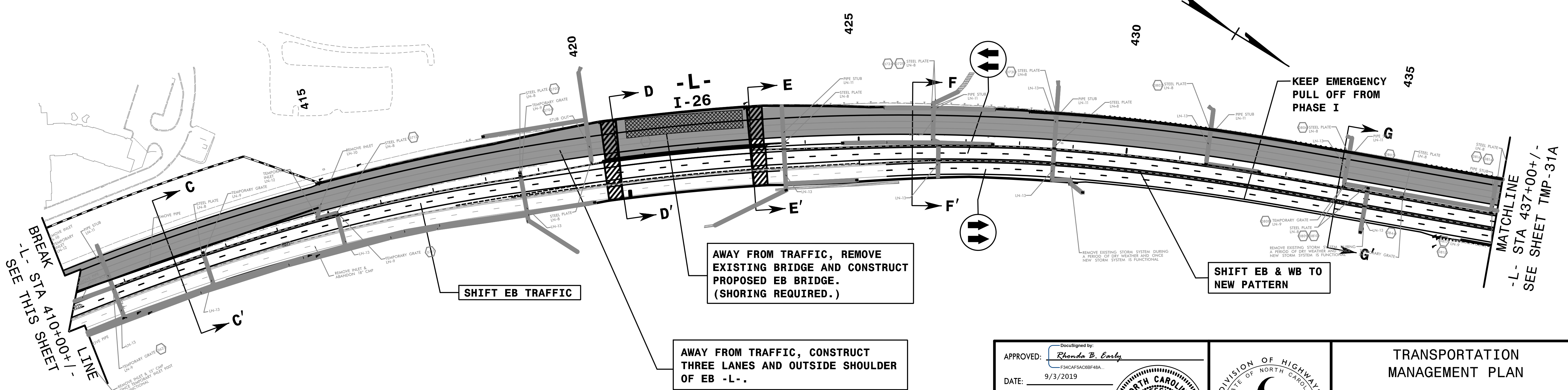

BREAK -L- STA 410+00+/- SEE THIS SHEET

SHIFT EB TRAFFIC

AWAY FROM TRAFFIC, REMOVE EXISTING BRIDGE AND CONSTRUCT PROPOSED EB BRIDGE. (SHORING REQUIRED.)

AWAY FROM TRAFFIC, CONSTRUCT THREE LANES AND OUTSIDE SHOULDER OF EB -L-.

SHIFT EB & WB TO NEW PATTERN

KEEP EMERGENCY PULL OFF FROM PHASE I

MATCHLINE -L- STA 437+00+/- SEE SHEET TMP-31A

REFER TO SHEET TMP-32 FOR CUT SECTIONS.

HNTB HNTB NORTH CAROLINA, P.C.
343 E. Six Forks Road, Suite 200
Raleigh, North Carolina 27609
NC License No: C-1554

APPROVED: *Rhonda B. Early*
DATE: 9/3/2019

DocuSigned by:
F34CFA5AC8BF48A...

PROFESSIONAL ENGINEER
SEAL
023521
RHONDA B. EARLY

DOCUMENT NOT CONSIDERED FINAL
UNLESS ALL SIGNATURES COMPLETED



TRANSPORTATION
MANAGEMENT PLAN

PHASE II
OVERVIEW

1:37:02 PM
...TrafficControl\TCP\OV_p2_L.dgn
9/3/2019

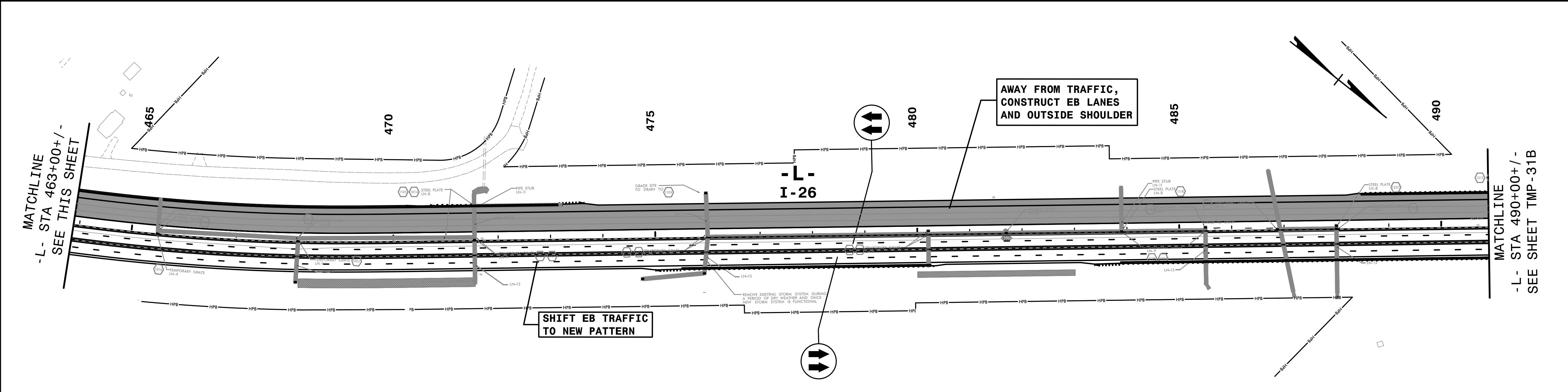
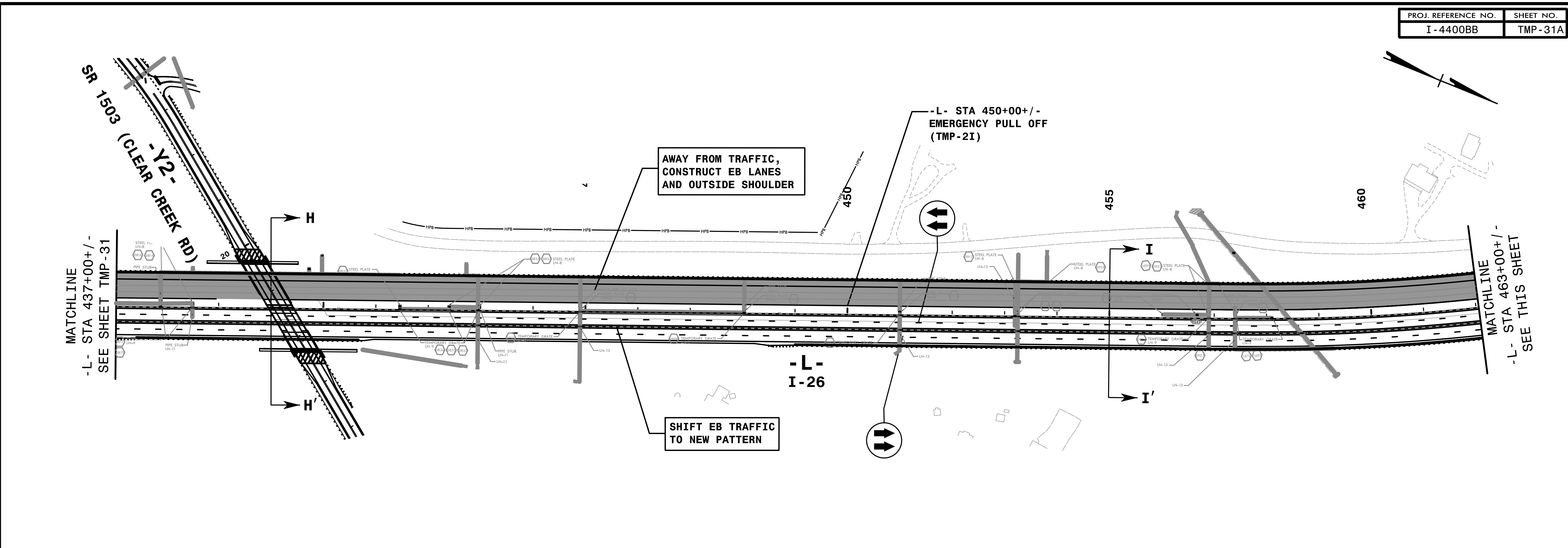

REFER TO SHEETS TMP-32 & TMP-32A FOR CUT SECTIONS.

1:37:14 PM
I:\TrafficControl\TCP\01_V2_2.dgn
9/3/2019



APPROVED: *Rhonda B. Early*
 DATE: 9/3/2019

DocuSigned by:
 F34CAFAC8BF48A...

PROFESSIONAL ENGINEER
 NORTH CAROLINA
 SEAL
 023521
 RHONDA B. EARLY

DOCUMENT NOT CONSIDERED FINAL UNLESS ALL SIGNATURES COMPLETED

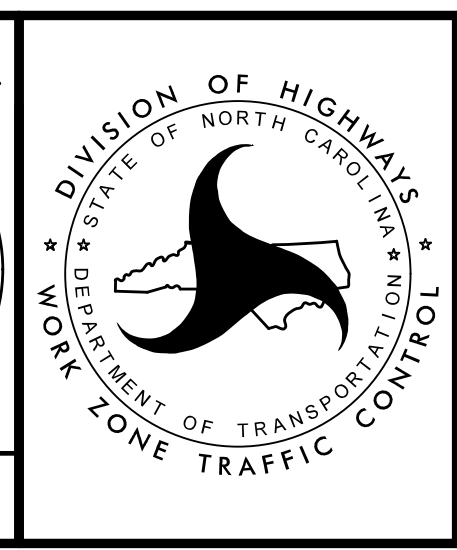

TRANSPORTATION MANAGEMENT PLAN

PHASE II OVERVIEW

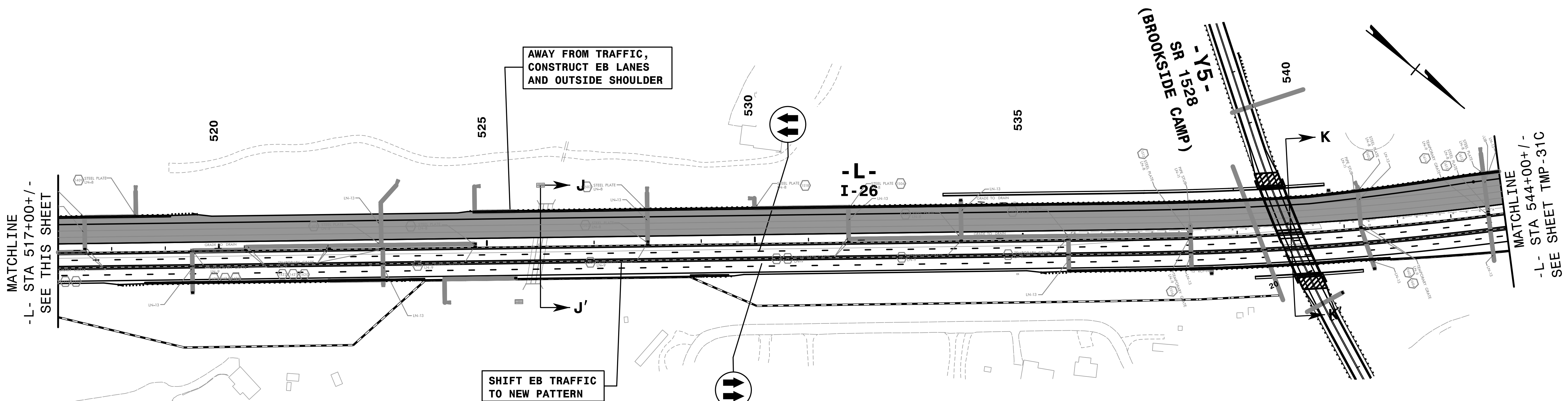
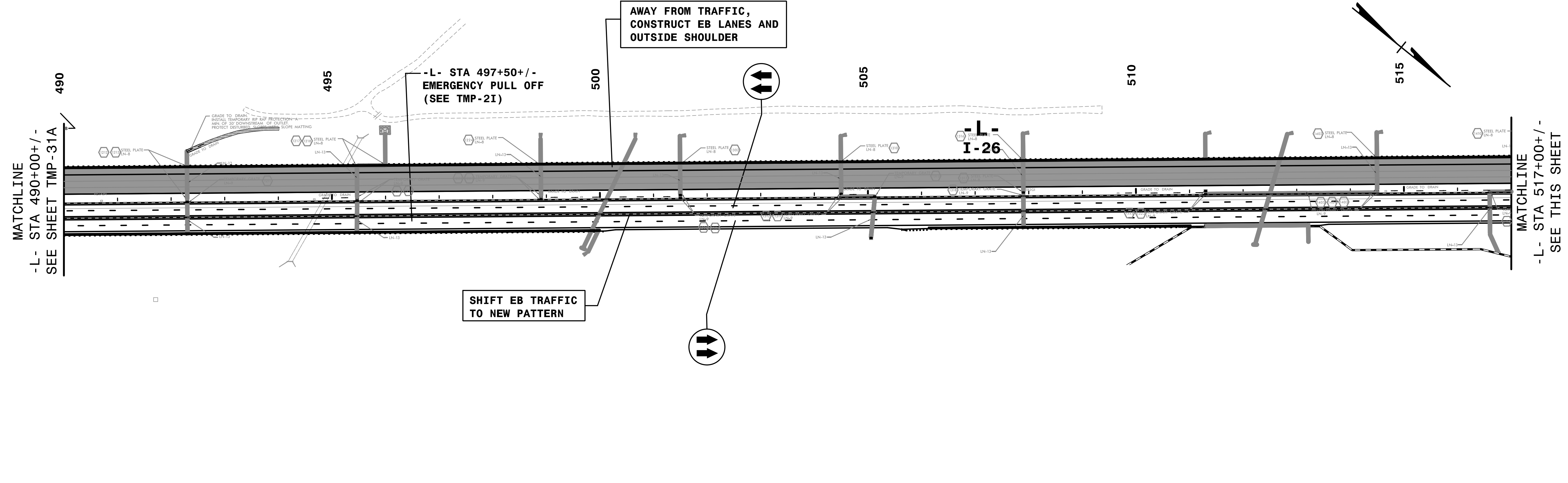

1:37:26 PM
...:\TrafficControl\TCP\0_V\p2_3.dgn
9/3/2019

HNTB HNTB NORTH CAROLINA, P.C.
343 E. Six Forks Road, Suite 200
Raleigh, North Carolina 27609
NC License No: C-1554

APPROVED: *Rhonda B. Early*
DATE: 9/3/2019

DocuSigned by:
Rhonda B. Early
F34CFA5AC8BF48A...

PROFESSIONAL ENGINEER
NORTH CAROLINA
SEAL
023521
RHONDA B. EARLY

DOCUMENT NOT CONSIDERED FINAL UNLESS ALL SIGNATURES COMPLETED



TRANSPORTATION MANAGEMENT PLAN

PHASE II OVERVIEW

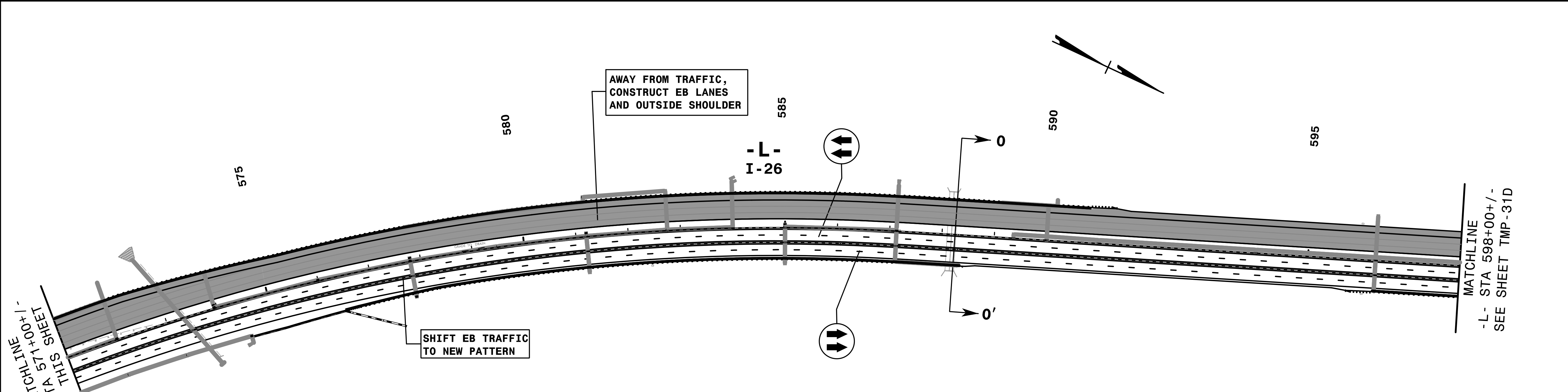
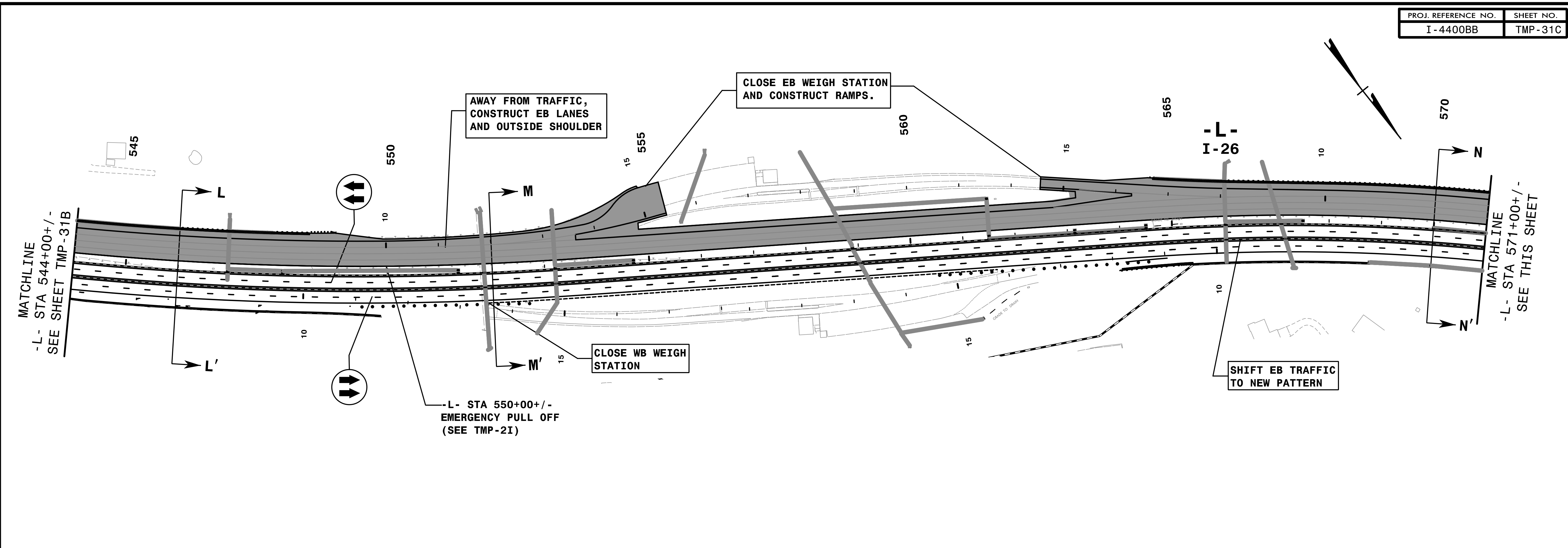

1:37:58 PM
...:\TrafficControl\TCP\OV_P2_4.dgn
9/3/2019

MATCHLINE
-L- STA 575+00+/-
SEE THIS SHEET
TMP-31B

MATCHLINE
-L- STA 598+00+/-
SEE SHEET TMP-31D



APPROVED: *Rhonda B. Early*
DATE: 9/3/2019

DocuSigned by:
Rhonda B. Early
F34CAFAC8BF48A...

SEAL
023521
NORTH CAROLINA
PROFESSIONAL
ENGINEER
RHONDA B. EARLY

**DOCUMENT NOT CONSIDERED FINAL
UNLESS ALL SIGNATURES COMPLETED**

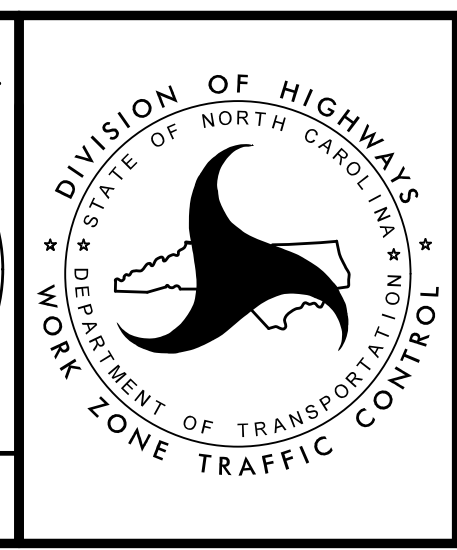

TRANSPORTATION
MANAGEMENT PLAN

PHASE II
OVERVIEW

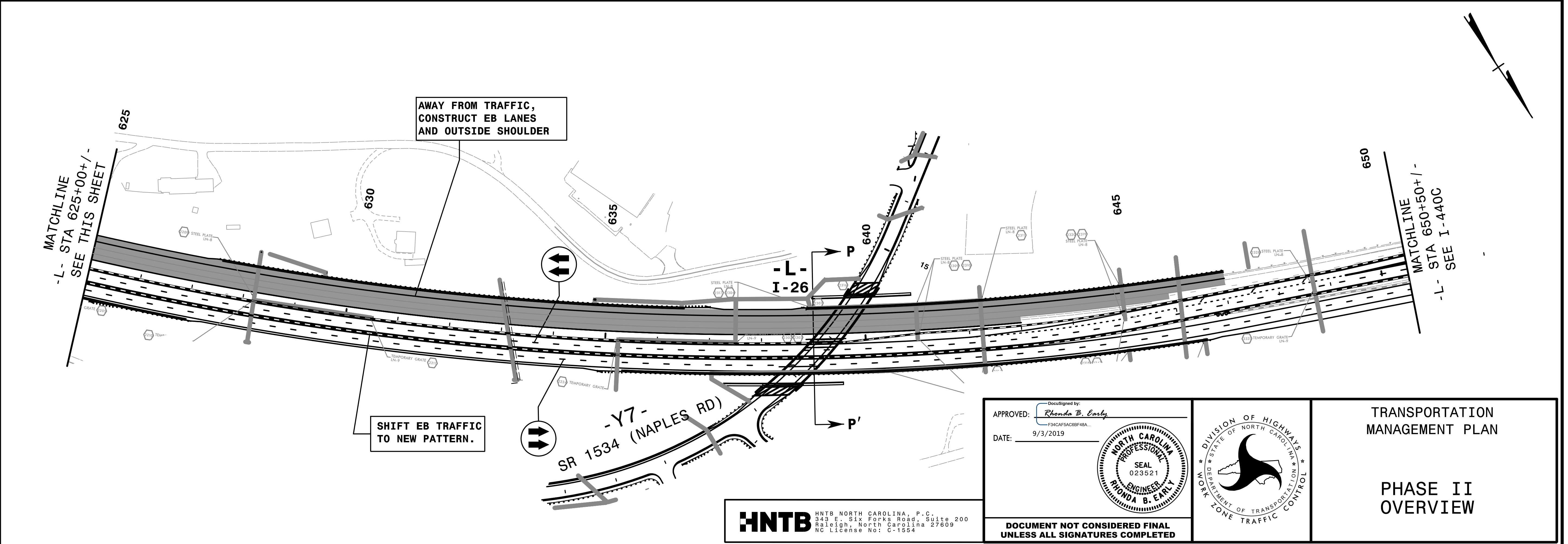
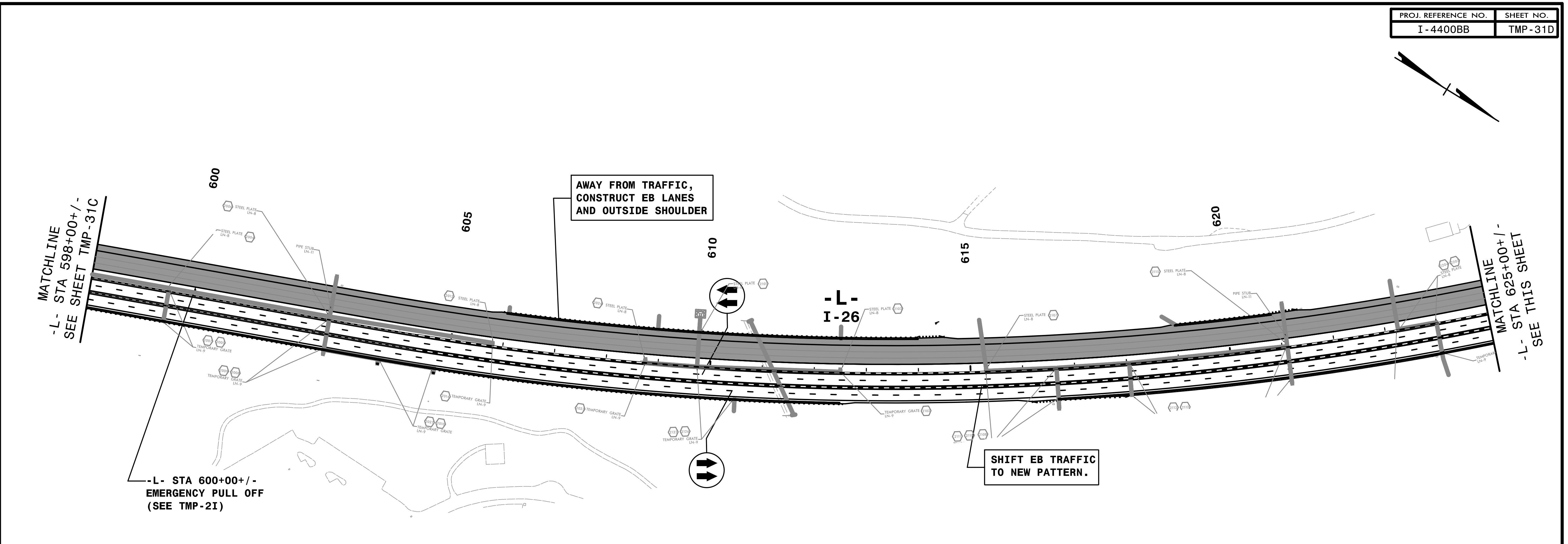

1:38:25 PM
...:\TrafficControl\TCP\OV_P2_5.dgn
9/3/2019

HNTB HNTB NORTH CAROLINA, P.C.
343 E. SIX FORKS ROAD, SUITE 200
RALEIGH, NORTH CAROLINA 27609
NC LICENSE NO: C-1554

APPROVED: *Rhonda B. Early*
DocuSigned by:
F34CAFACBFB48A...
 DATE: 9/3/2019

PROFESSIONAL ENGINEER
 NORTH CAROLINA
 SEAL
 023521
 RHONDA B. EARLY

**DOCUMENT NOT CONSIDERED FINAL
 UNLESS ALL SIGNATURES COMPLETED**



TRANSPORTATION
 MANAGEMENT PLAN

PHASE II
 OVERVIEW