



**This electronic collection of documents is provided
for the convenience of the user
and is Not a Certified Document –**

**The documents contained herein were originally issued
and sealed by the individuals whose names and license
numbers appear on each page, on the dates appearing
with their signature on that page.**

**This file or an individual page
shall not be considered a certified document.**

TIP NO. B-5905	SHEET NO. PMP - 2
APPROVED:  DocuSigned by: Matthew Thigpen FD15553E9193410	
DATE: _____	
SEAL 	
DOCUMENT NOT CONSIDERED FINAL UNLESS ALL SIGNATURES COMPLETED	

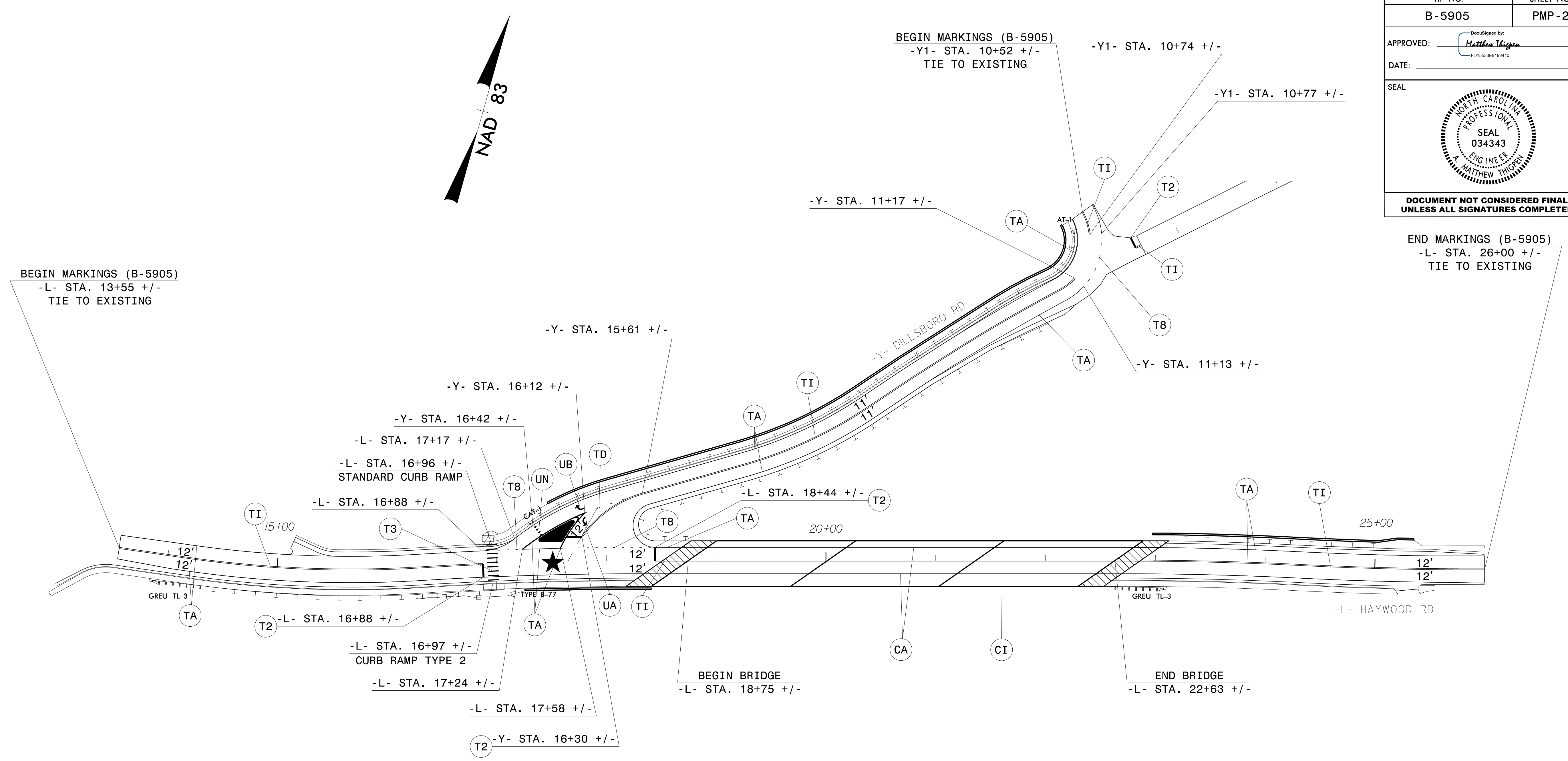

I:\29\2019
\\svb\ap\npro\raleigh\3842\9 NCDOT B-5905 Final Plans\NCDOT\Traffic\Pavement\Mar-King\B5905_pm_psh4.dgn
User: MThigpen

★ SIGNALIZED

PAVEMENT MARKING DETAIL