

**This electronic collection of documents is provided  
for the convenience of the user  
and is Not a Certified Document –**

**The documents contained herein were originally issued  
and sealed by the individuals whose names and license  
numbers appear on each page, on the dates appearing  
with their signature on that page.**

**This file or an individual page  
shall not be considered a certified document.**

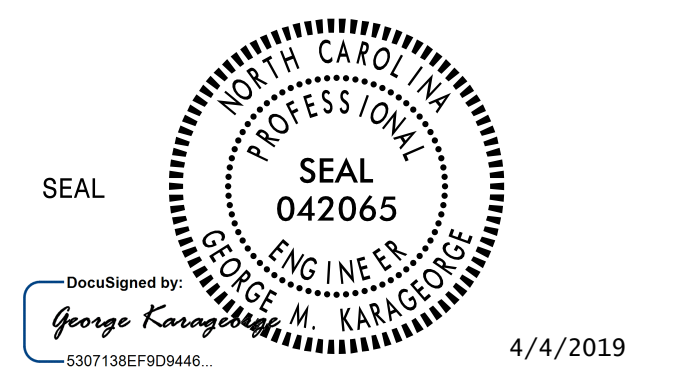









DOCUMENT NOT CONSIDERED FINAL UNLESS ALL SIGNATURES COMPLETED





**Michael Baker**  
INTERNATIONAL

## PAVEMENT MARKING LEGEND

THERMOPLASTIC PAVEMENT MARKING LINES				
CODE	COLOR	LINE WIDTH	DESCRIPTION	THICKNESS
T2	WHITE	24"	STOPBAR	90 MILS
T3	WHITE	24"	CROSSWALK LINE HI-VISIBILITY	90 MILS
TO	WHITE	8"	DIAGONAL	90 MILS
TP	YELLOW	8"	DIAGONAL	90 MILS
TV	YELLOW	12"	DIAGONAL	90 MILS

POLYUREA PAVEMENT MARKING LINES			
CODE	COLOR	LINE WIDTH	DESCRIPTION
V8	WHITE	4"	MINISKIP 2FT-6FT
V19	YELLOW	4"	CENTER DOUBLE SOLID/SKIP
VA	WHITE	4"	EDGE LINE
VB	YELLOW	4"	EDGE LINE
VC	WHITE	4"	SKIP
VD	WHITE	4"	MINISKIP 3FT-9FT
VE	WHITE	4"	LANELINE
VI	YELLOW	4"	CENTER DOUBLE SOLID/SOLID
VN	WHITE	8"	GORELINE

THERMOPLASTIC SYMBOLS & CHARACTERS				
	CODE	COLOR	DESCRIPTION	THICKNESS
	UA	WHITE	LEFT TURN ARROW	90 MILS
	UB	WHITE	RIGHT TURN ARROW	90 MILS
	UC	WHITE	STRAIGHT ARROW	90 MILS
	UD	WHITE	LEFT/STRAIGHT ARROW	90 MILS
	UE	WHITE	RIGHT/STRAIGHT ARROW	90 MILS
	UI	WHITE	ALPHANUMERIC CHARACTER	90 MILS
	UN	WHITE	24" YIELD LINE TRIANGLE	90 MILS

PAVEMENT MARKERS			
	CODE	COLOR	DESCRIPTION
	MA	YELLOW/YELLOW	PERMANENT RAISED
	MB	CRYSTAL/RED	PERMANENT RAISED
	ME	YELLOW/YELLOW	SNOWPLOWABLE
	MF	CRYSTAL/RED	SNOWPLOWABLE

**NOTE:**  
USE SNOWPLOWABLE PAVEMENT MARKERS ON PROJECT EXCEPT ON MONOLITHIC ISLANDS ON US 19 BUS, SHOWN ON PMP-9.



PROJECT REFERENCE NO.	SHEET NO.
R-5735	PMP-3
<p><b>DOCUMENT NOT CONSIDERED FINAL UNLESS ALL SIGNATURES COMPLETED</b></p> <p><b>Michael Baker INTERNATIONAL</b></p>	

**CR-1** STANDARD DIAGONAL CURB RAMP  
SEE RDWY. STD. 1205.07

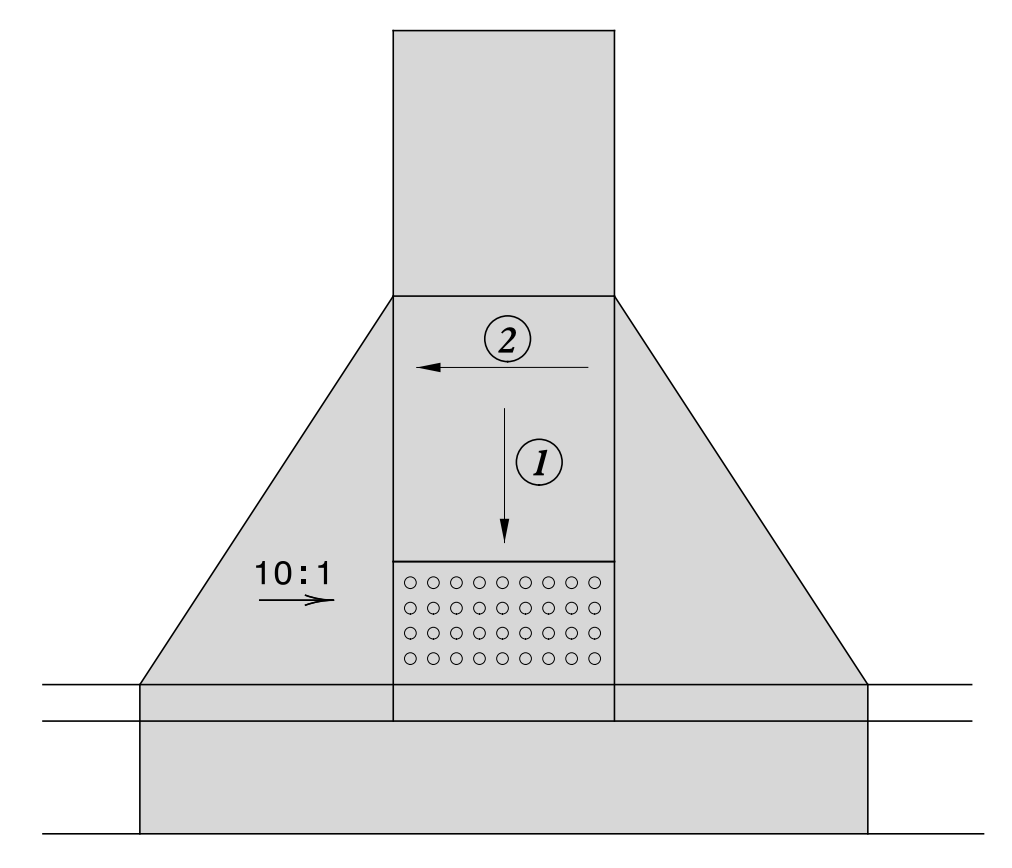

**CR-2** DIRECTIONAL CURB RAMP

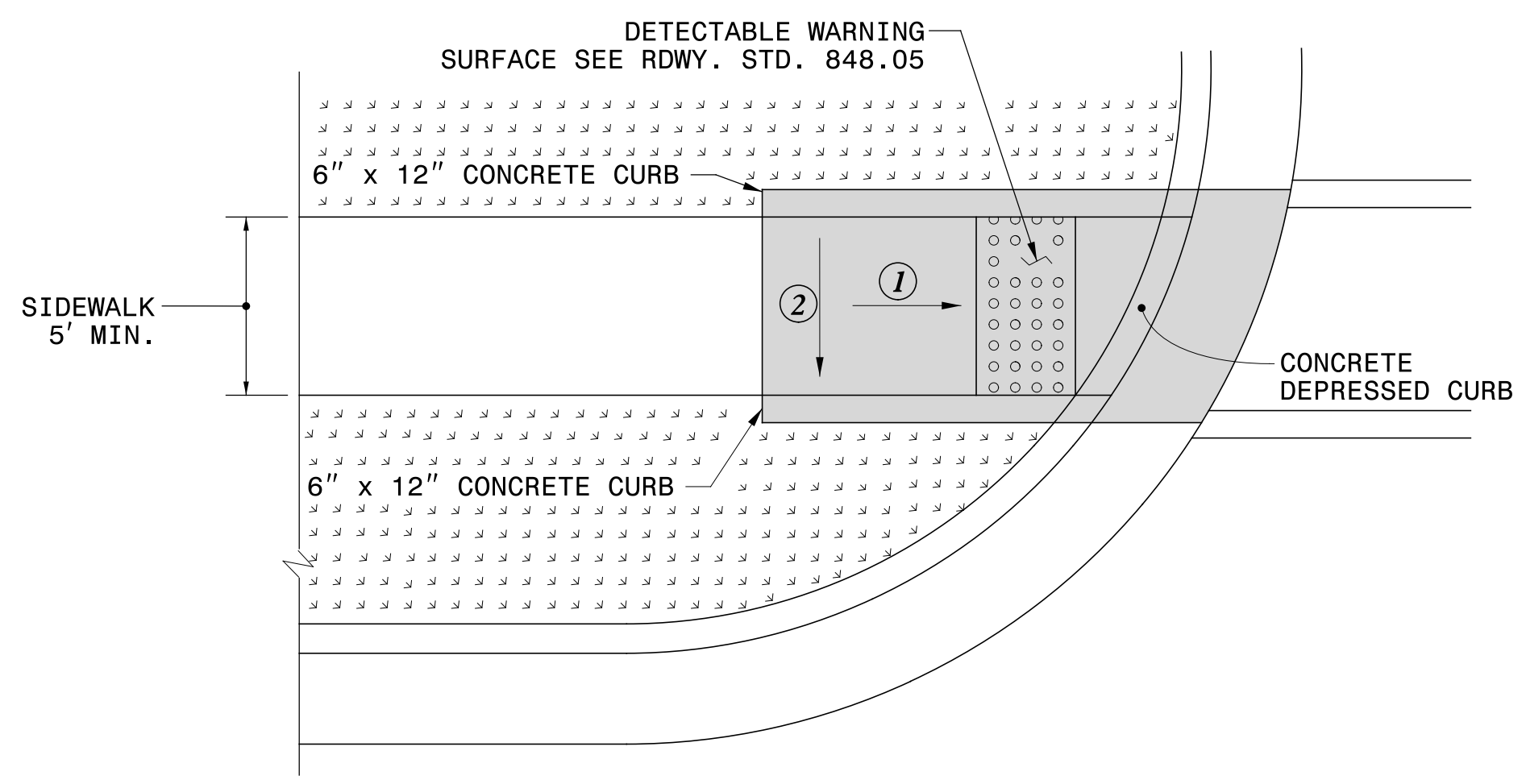

**CR-3** DIAGONAL CURB RAMP (SPACE RESTRICTED)

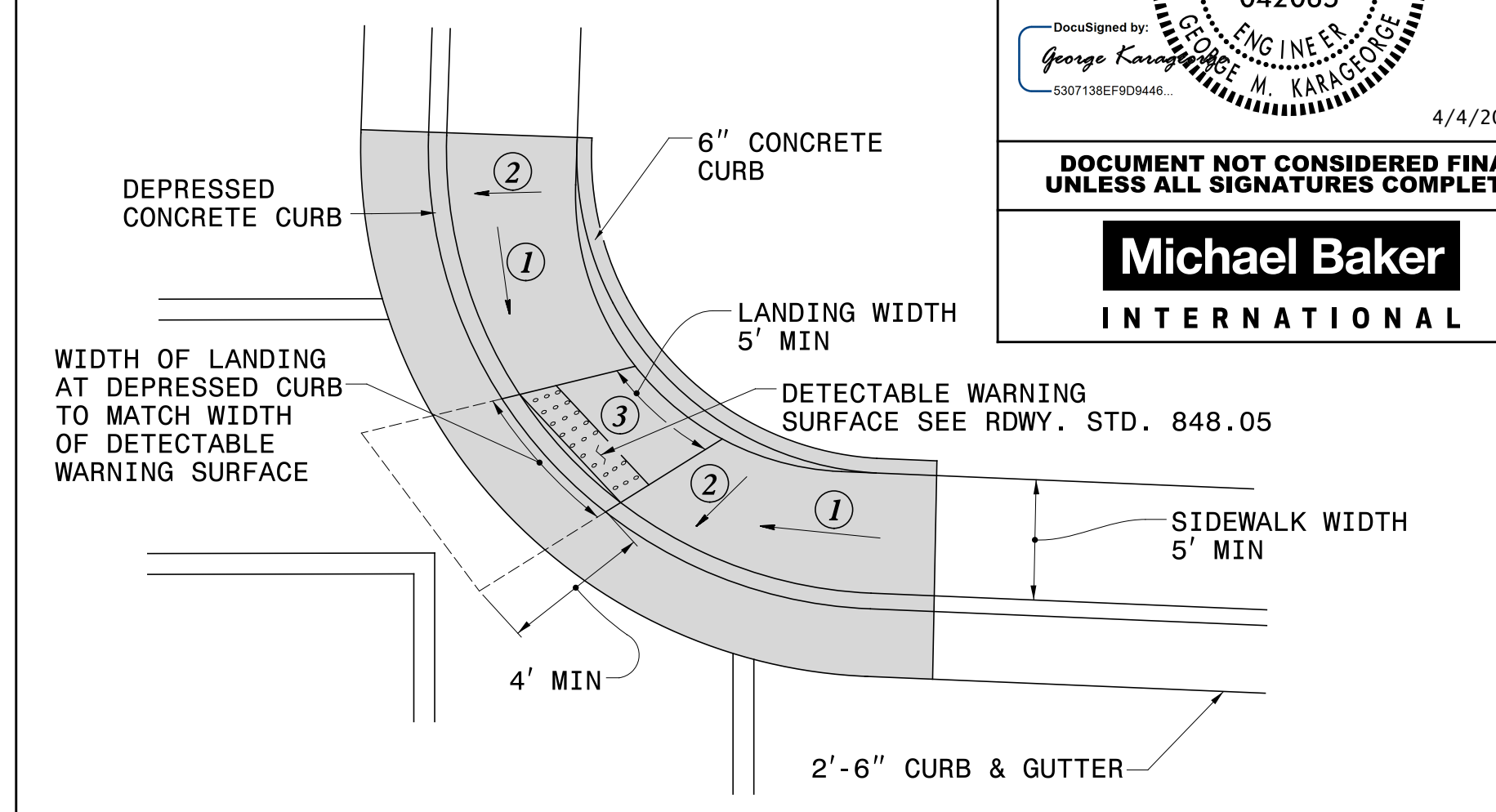

**CR-4** ISLAND CURB RAMP

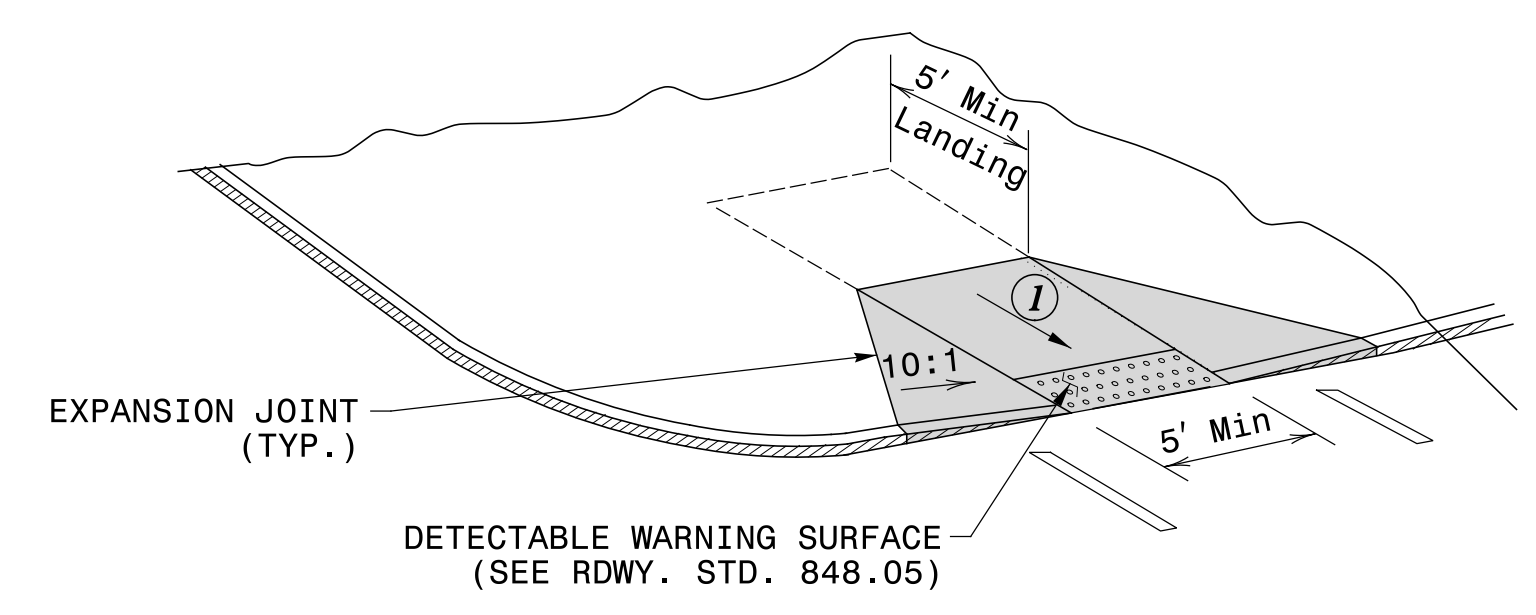

**CR-5** ISLAND CURB RAMP - MODIFIED

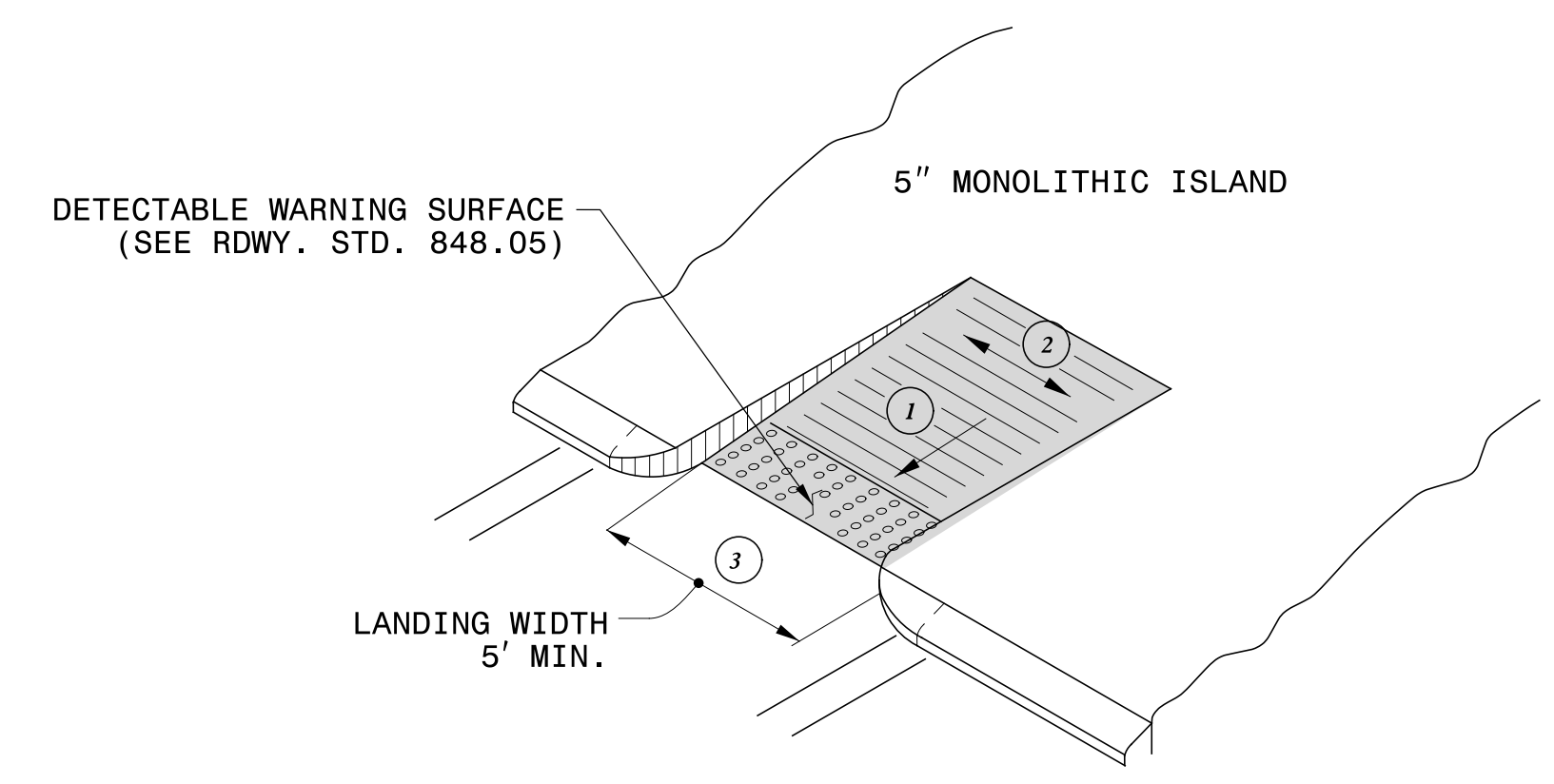

**CR-6** CURB RAMP - TYPE 1A

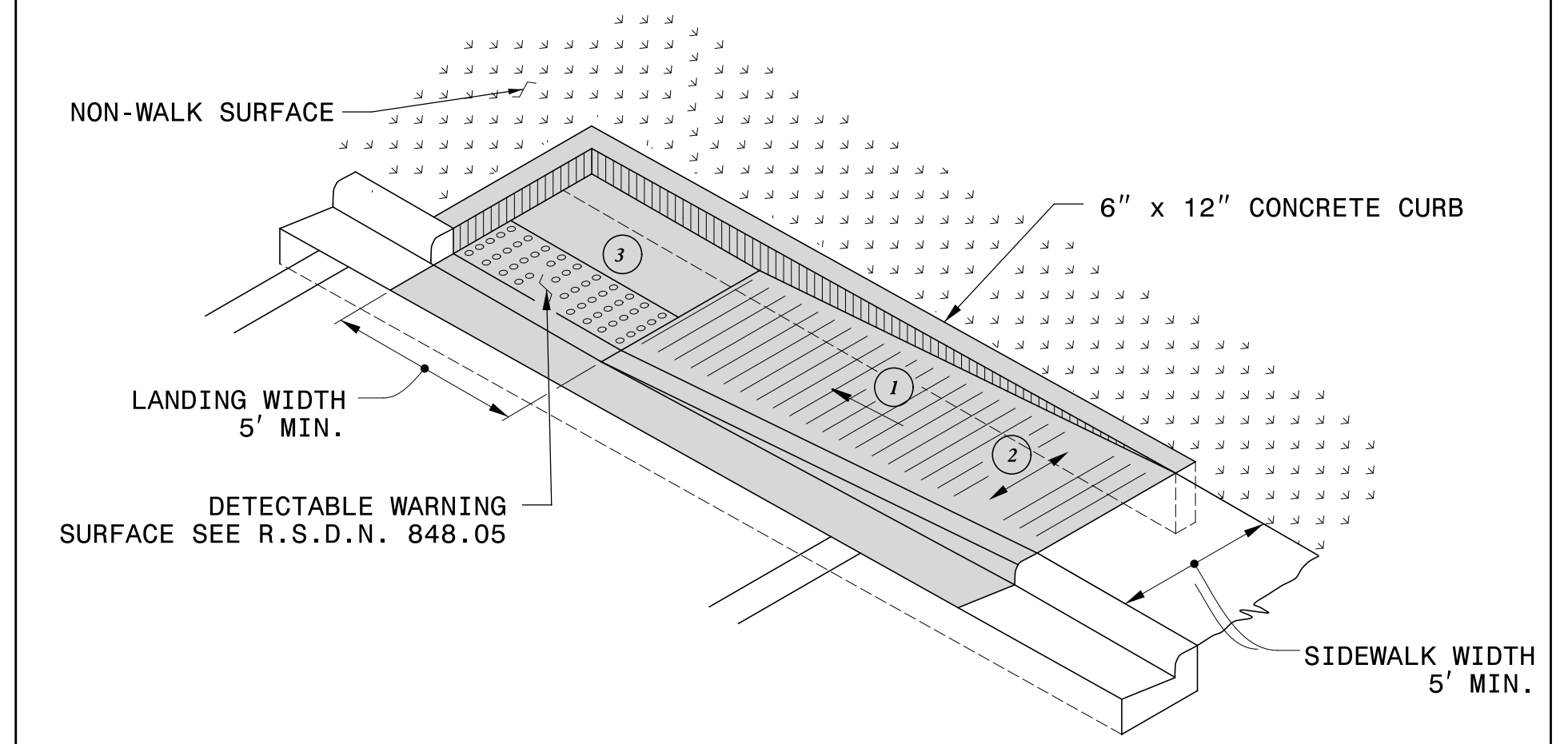

**CR-7** PARALLEL CURB RAMP - TYPE 3

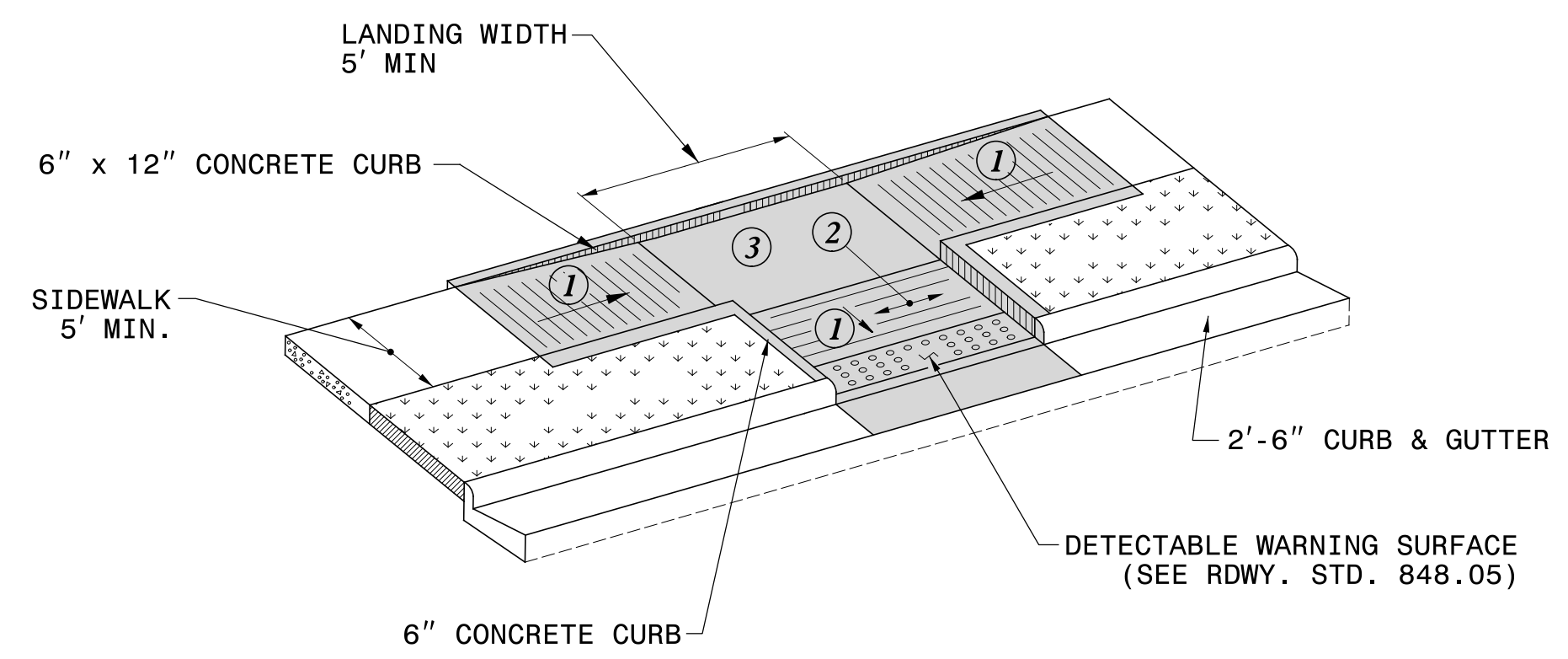

- ① RAMP SLOPE: 8.33% (12:1) MAX.
- ② CROSS SLOPE: 2.00% MAX.
- ③ CURB RAMPS REQUIRE A (4'-0") MINIMUM LANDING WITH A MAXIMUM CROSS SLOPE AND LONGITUDINAL SLOPE OF 2.00% WHERE PEDESTRIANS PERFORM TURNING MANEUVERS. SLOPE TO DRAIN TO CURB.
- ④ REFER TO RDWY. STD. 848.05 SHEET 3 OF 3 FOR ALL RAMP NOTES
- ⑤ PAY LIMITS FOR CURB RAMPS (CALCULATE BASED ON NUMBER OF DETECTABLE WARNING SURFACES)

CURB RAMPS

3/13/2019 R:\Traffic\Pavement Marking\Sheets\NR-5735\_PMP\_03\_CURB\_RAMP\_DET.dgn Birgit.Mackenzie

PROJECT REFERENCE NO. R-5735	SHEET NO. PMP-4
<small>DocuSigned by: George Karageorge 3307138E2F0044E...</small>	
<b>DOCUMENT NOT CONSIDERED FINAL UNLESS ALL SIGNATURES COMPLETED</b>	
<b>Michael Baker INTERNATIONAL</b>	

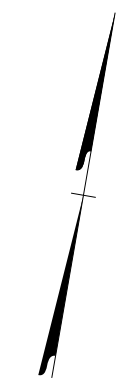

PROPOSED PAVEMENT MARKINGS

3/13/2019  
R:\Traffic\Pavement Marking\Sheets\NR-5735 PMP\_04.dgn  
Birgit.Mackenzie

PROJECT REFERENCE NO. R-5735	SHEET NO. PMP-5
SEAL 042065 GEORGE M. KARAGIOS PROFESSIONAL ENGINEER STATE OF NORTH CAROLINA 4/4/2019	
<b>DOCUMENT NOT CONSIDERED FINAL UNLESS ALL SIGNATURES COMPLETED</b>	
<b>Michael Baker</b> INTERNATIONAL	

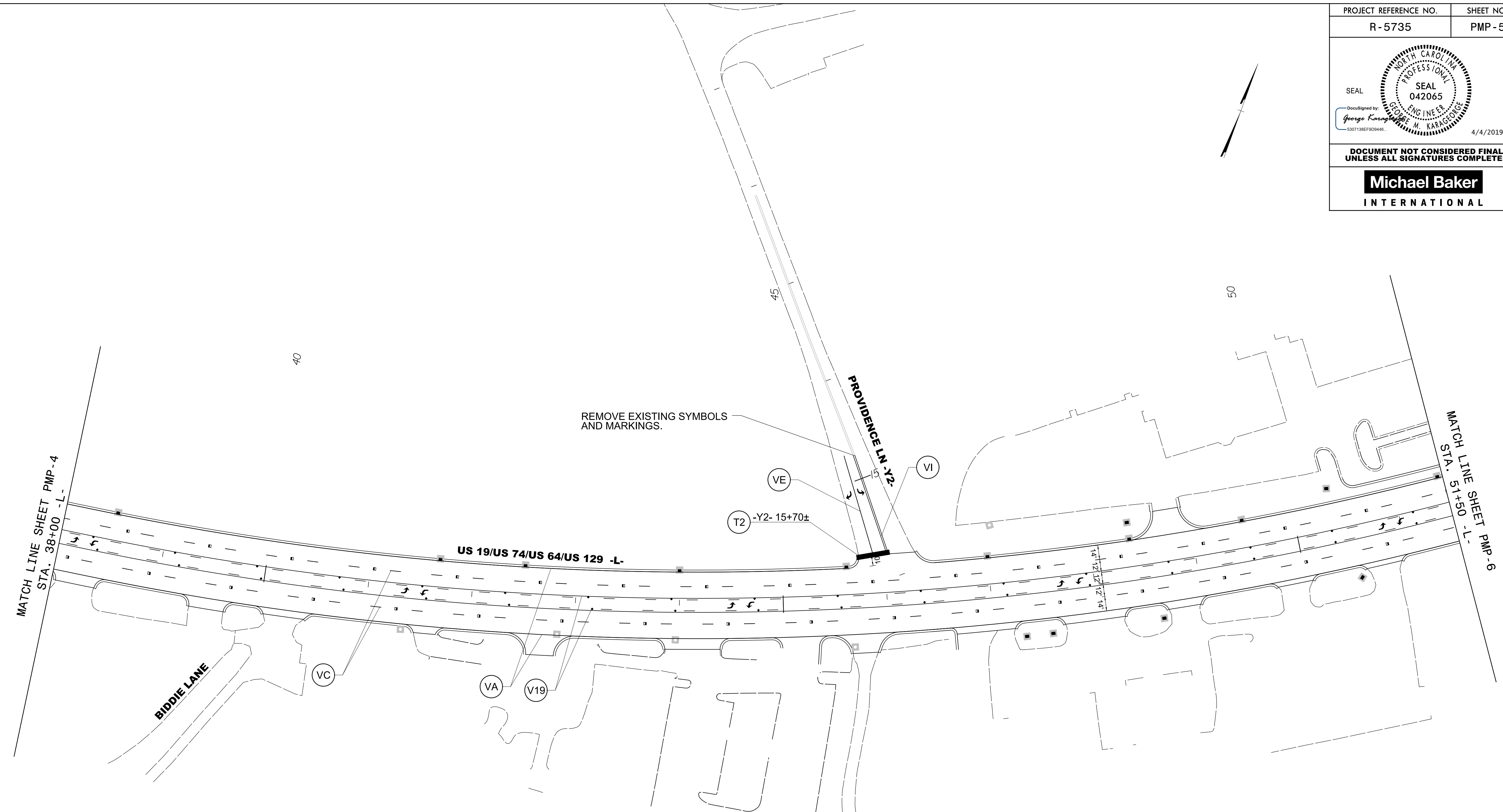



PROPOSED PAVEMENT MARKINGS

3/13/2019  
R:\Traffic\Pavement Marking\Sheets\NR-5735 PMP 05.dgn  
Birgit Mackenzie





PROJECT REFERENCE NO. R-5735	SHEET NO. PMP-7
	
<small>DOCUMENT NOT CONSIDERED FINAL UNLESS ALL SIGNATURES COMPLETED</small>	
	

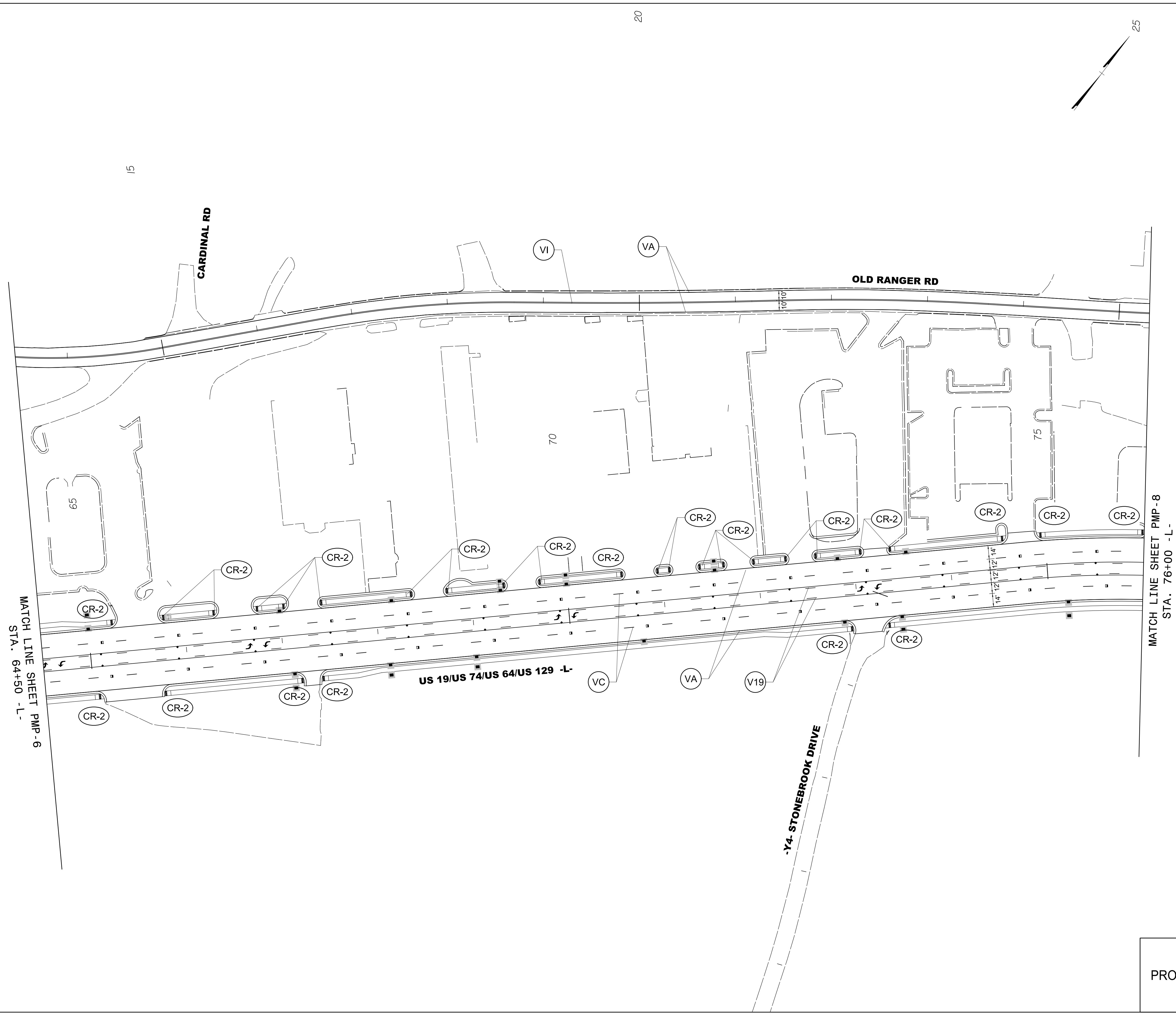

3/13/2019  
 R:\Traffic\Pavement Marking\Sheets\NR-5735 PMP 07.dgn  
 Birgit.Mackenzie

PROPOSED PAVEMENT MARKINGS



SEAL

DocuSigned by:  
George Karageorge  
5307138EF9D0448

4/4/2019

DOCUMENT NOT CONSIDERED FINAL UNLESS ALL SIGNATURES COMPLETED

**Michael Baker**  
INTERNATIONAL

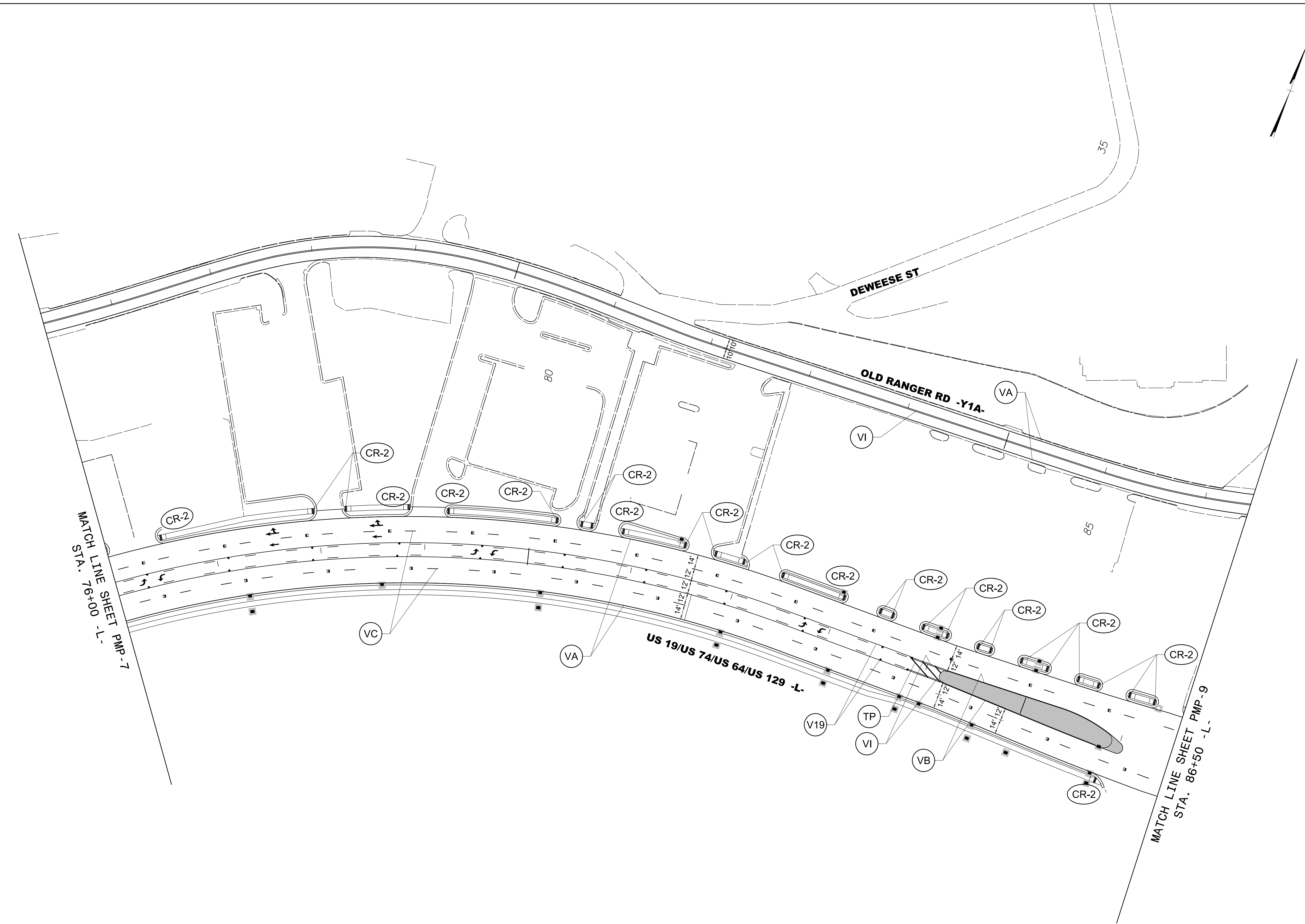

3/15/2019  
R:\Traffic\Pavement Marking\Sheets\NR-5735 PMP\_08.dgn  
Birgit Mackenzie

PROPOSED PAVEMENT MARKINGS





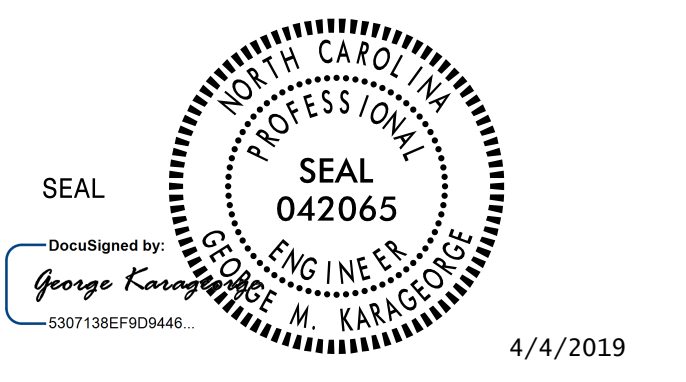

DOCUMENT NOT CONSIDERED FINAL UNLESS ALL SIGNATURES COMPLETED

**Michael Baker**  
INTERNATIONAL

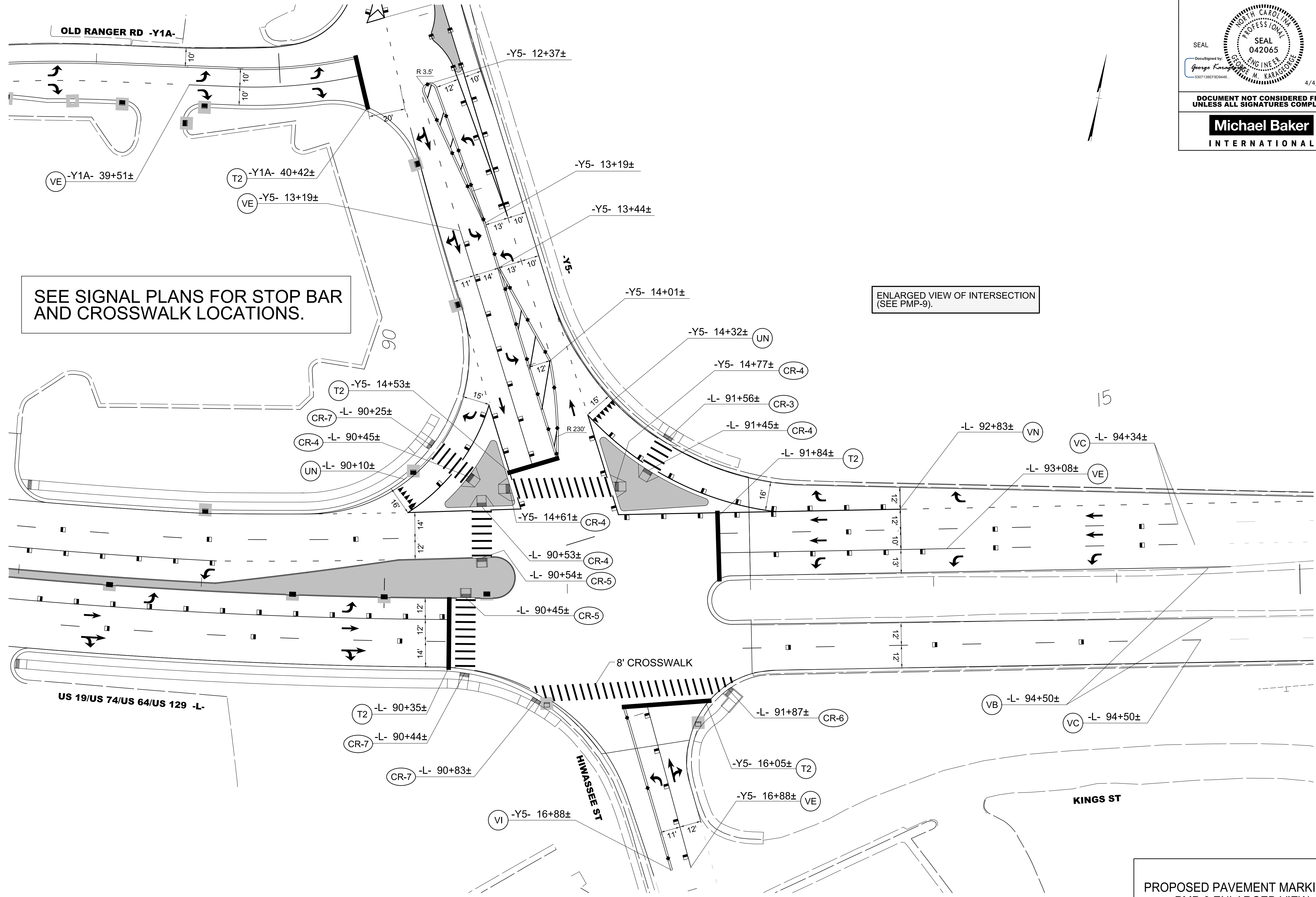

SEE SIGNAL PLANS FOR STOP BAR AND CROSSWALK LOCATIONS.

ENLARGED VIEW OF INTERSECTION (SEE PMP-9).

PROPOSED PAVEMENT MARKINGS  
PMP-9 ENLARGED VIEW

3/13/2019  
R:\Traffic\Pavement Marking\Sheets\NR-5735\_PMP\_10.dgn  
Birgit Mackenzie