

PROJECT REFERENCE NO. R-5735	SHEET NO. EC-10/CONST.04
RW SHEET NO.	
ROADWAY DESIGN ENGINEER	HYDRAULICS ENGINEER

8/17/99

REVISIONS

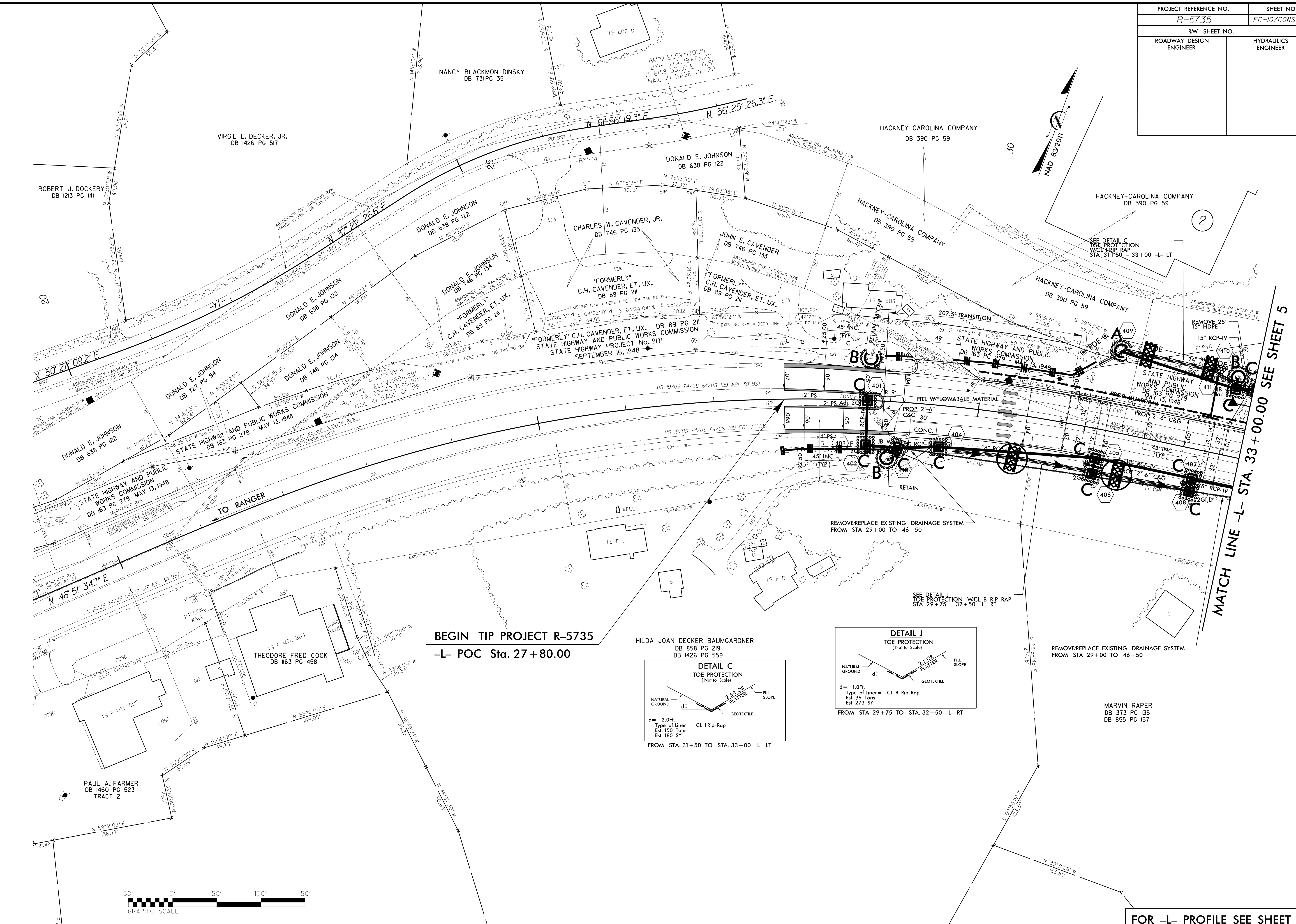

BEGIN TIP PROJECT R-5735
-L- POC Sta. 27 + 80.00

HILDA JOAN DECKER BAUMGARDNER
DB 858 PG 219
DB 1426 PG 559

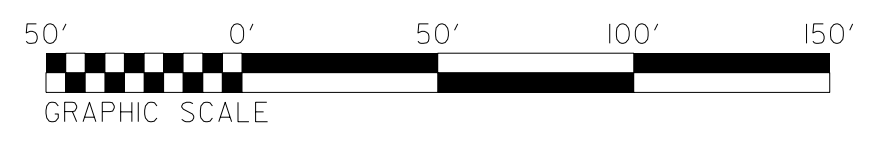
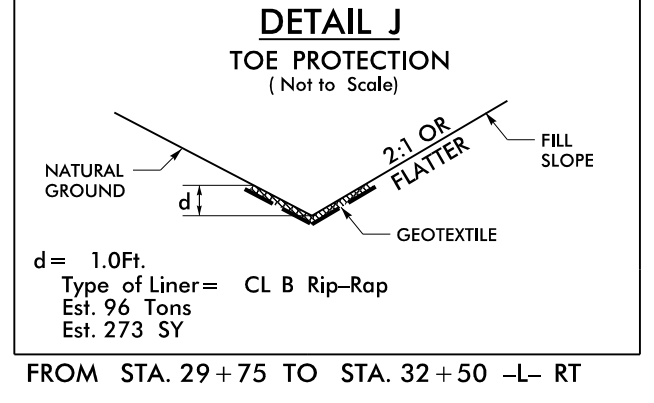
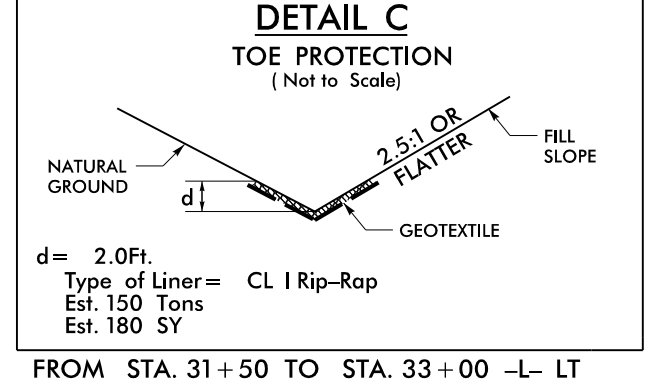

MATCH LINE -L- STA. 33 + 00.00 SEE SHEET 5

FOR -L- PROFILE SEE SHEET 10