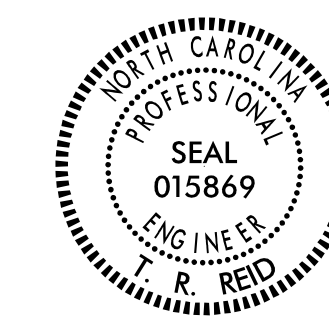

**This electronic collection of documents is provided
for the convenience of the user
and is Not a Certified Document –**

**The documents contained herein were originally issued
and sealed by the individuals whose names and license
numbers appear on each page, on the dates appearing
with their signature on that page.**

**This file or an individual page
shall not be considered a certified document.**

PROJECT REFERENCE NO.	SHEET NO.
B-4438	PMP-1
APPROVED: 	
DATE: 2/22/2019	
SEAL	
	
DOCUMENT NOT CONSIDERED FINAL UNLESS ALL SIGNATURES COMPLETED	

STATE OF NORTH CAROLINA
DEPARTMENT OF TRANSPORTATION

**PAVEMENT MARKING PLANS
BRUNSWICK COUNTY**

**LOCATION: BRIDGE NO. 47 OVER BEAR PEN ISLAND SWAMP
ON NC 211 (GREEN SWAMP ROAD)**

PROJECT: B-4438

CONTRACT:

ROADWAY STANDARD DRAWINGS

THE FOLLOWING ROADWAY STANDARDS AS SHOWN IN "ROADWAY STANDARD DRAWINGS" - CONTRACT STANDARDS AND DEVELOPMENT UNIT - N.C. DEPARTMENT OF TRANSPORTATION- RALEIGH, N.C. DATED JANUARY 2018 ARE APPLICABLE TO THIS PROJECT AND BY REFERENCE HEREBY ARE CONSIDERED A PART OF THESE PLANS:

STD. NO.	TITLE
1205.01	PAVEMENT MARKINGS - LINE TYPES AND OFFSETS
1205.02	PAVEMENT MARKINGS - TWO LANE AND MULTILANE ROADWAYS
1205.12	PAVEMENT MARKINGS - BRIDGES
1250.01	RAISED PAVEMENT MARKERS - INSTALLATION SPACING
1253.01	RAISED PAVEMENT MARKERS - SNOWPLOWABLE

GENERAL NOTES

THE FOLLOWING GENERAL NOTES APPLY AT ALL TIMES FOR THE DURATION OF THE CONSTRUCTION PROJECT, EXCEPT WHEN OTHERWISE NOTED IN THE PLAN, OR DIRECTED BY THE ENGINEER.

A) INSTALL PAVEMENT MARKINGS AND PAVEMENT MARKERS ON THE FINAL SURFACE AS FOLLOWS:

ROAD NAME	MARKING	MARKER
NC 211	THERMOPLASTIC	SNOWPLOWABLE

B) TIE PROPOSED PAVEMENT MARKING LINES TO EXISTING PAVEMENT MARKING LINES.

C) REMOVE / REPLACE ANY CONFLICTING / DAMAGED PAVEMENT MARKINGS AND MARKERS.

D) PASSING ZONES WILL BE DETERMINED IN THE FIELD AND MUST BE APPROVED BY THE ENGINEER.

PAVEMENT MARKING SCHEDULE

SYMBOL	DESCRIPTION
TA - WHITE EDGE LINE (4")	THERMOPLASTIC
TF - YELLOW SKIP LINE (4")	THERMOPLASTIC
TH - YELLOW SINGLE CENTER (4")	THERMOPLASTIC
TI - YELLOW DOUBLE CENTER (4")	THERMOPLASTIC
ME - SNOWPLOWABLE MARKER-YELLOW/YELLOW	MARKER

INDEX

SHEET NO.	DESCRIPTION
PMP-1	PAVEMENT MARKING PLAN COVER SHEET NOTES & SCHEDULE
PMP-2	PAVEMENT MARKING DETAIL

PLAN PREPARED BY: MOFFATT & NICHOL

<u>TIM REID, PE</u>	PROJECT ENGINEER
<u>DON DARITY, PE</u>	PROJECT DESIGN

PAVEMENT MARKING SCHEDULE

- TA** - THERMOPLASTIC - WHITE EDGE LINE (4")
- TF** - THERMOPLASTIC - YELLOW SKIP LINE (4")
- TH** - THERMOPLASTIC - YELLOW SINGLE CENTER (4")
- TI** - THERMOPLASTIC - YELLOW DOUBLE CENTER (4")
- ME** - SNOWPLOWABLE MARKER - YELLOW & YELLOW

NOTE:
 1. ALL STRIPING SHOWN SHALL BE THERMOPLASTIC MATERIAL

NAD NC GRID
 83 / N/A 2011

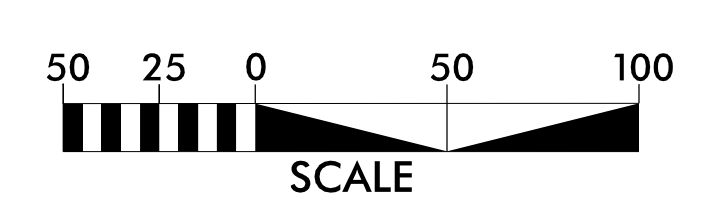
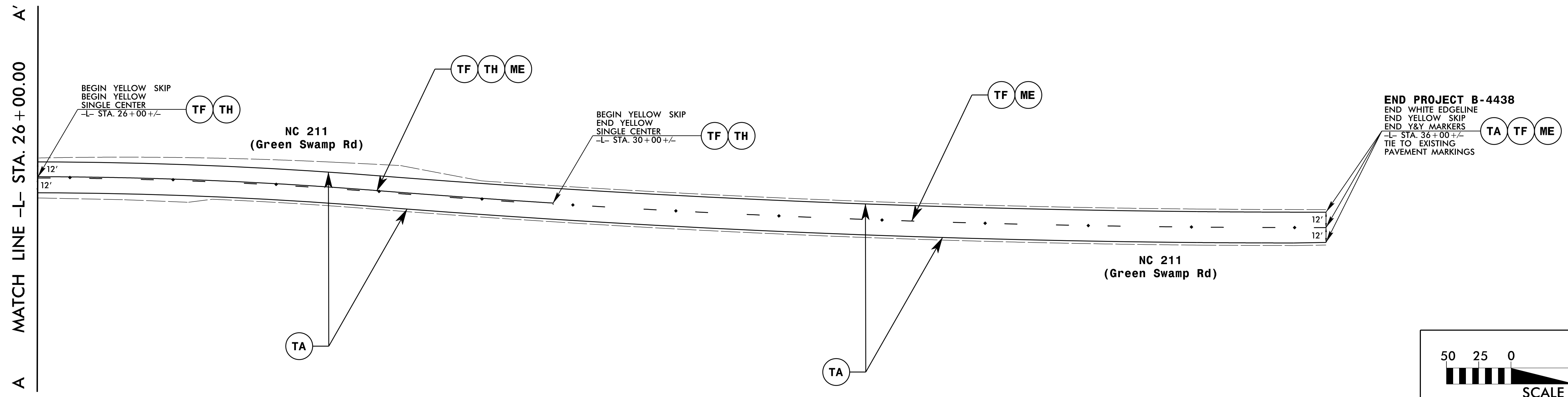
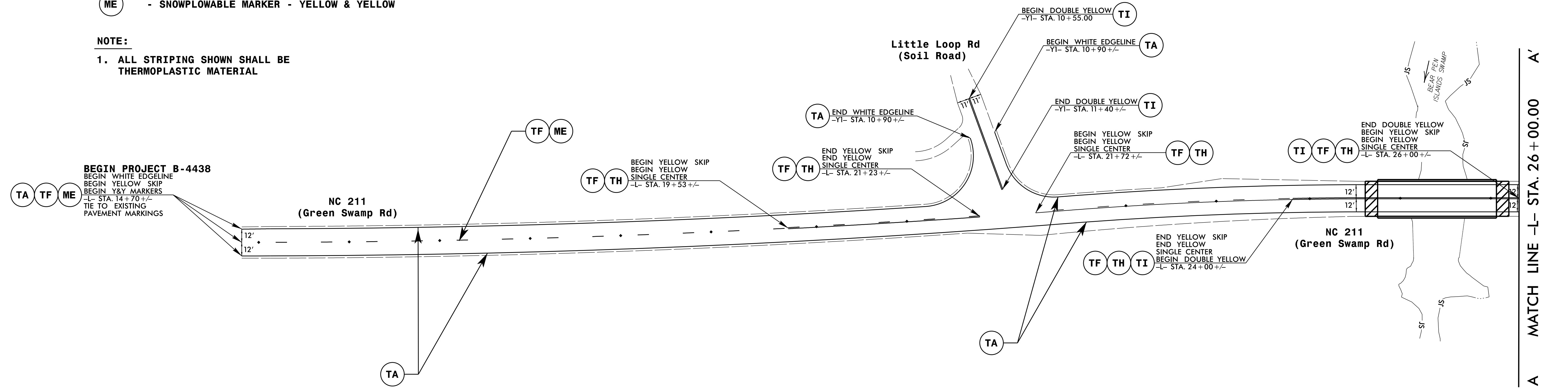

APPROVED: Timothy R. Reid DATE: 2/22/2019

SEAL

PROFESSIONAL SEAL
 015869
 ENGINEER
 T. R. REID

**PAVEMENT MARKING DETAIL
 NC 211
 (GREEN SWAMP ROAD)**

DOCUMENT NOT CONSIDERED FINAL
 UNLESS ALL SIGNATURES COMPLETED

5/14/09
 2/22/2019
 G:\PRA\9729-01\CADD\B4438\Traffic\NMP\B4438_r_dy_bmp02.dgn
 TnuFFman