

**This electronic collection of documents is provided
for the convenience of the user
and is Not a Certified Document –**

**The documents contained herein were originally issued
and sealed by the individuals whose names and license
numbers appear on each page, on the dates appearing
with their signature on that page.**

**This file or an individual page
shall not be considered a certified document.**

09.08/95
 SYSTEM\$\$\$\$\$
 DDN\$\$\$\$\$
 USER\$\$\$\$\$

TIP PROJECT: B-4968

STATE OF NORTH CAROLINA
DIVISION OF HIGHWAYS

| | |
|------------|-----------|
| T.I.P. NO. | SHEET NO. |
| B-4968 | UC-1 |

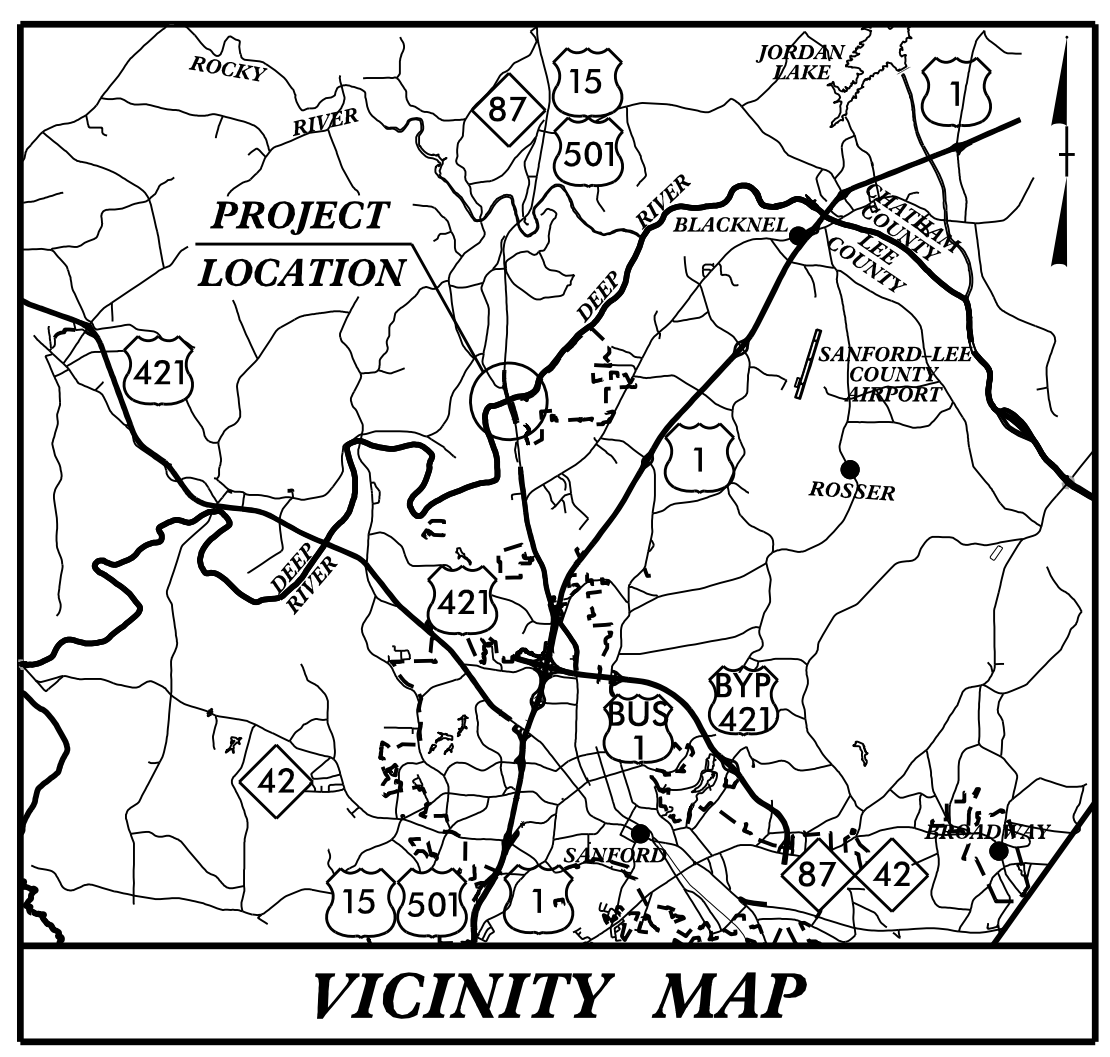

UTILITY CONSTRUCTION PLANS LEE & CHATHAM COUNTIES

LOCATION: BRIDGE NO. 10 OVER DEEP RIVER
ON US 15-501/NC 87

TYPE OF WORK: UTILITY CONSTRUCTION

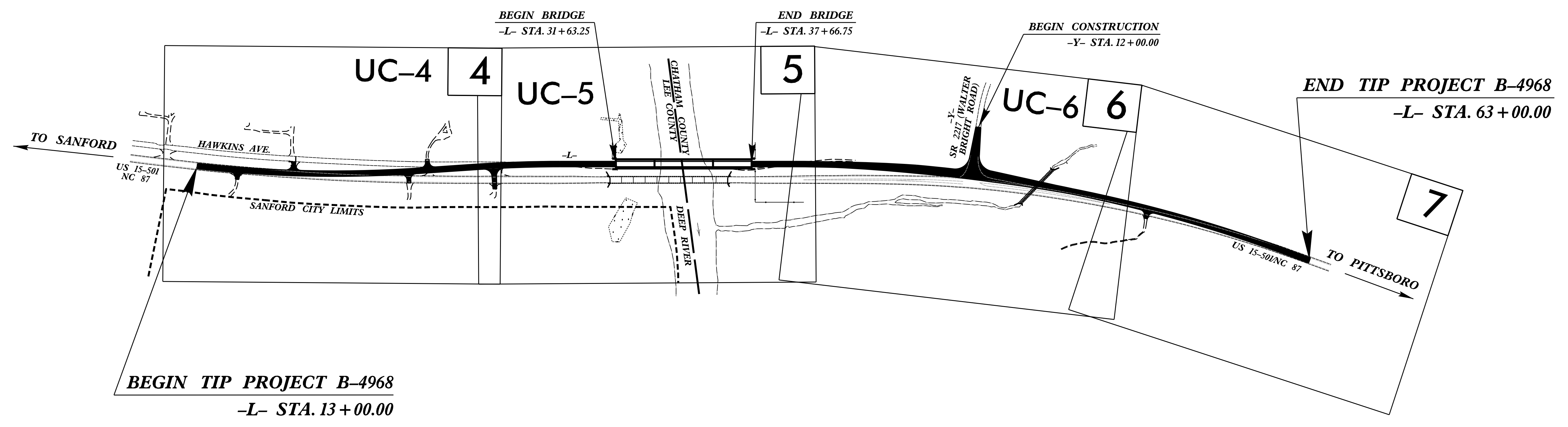
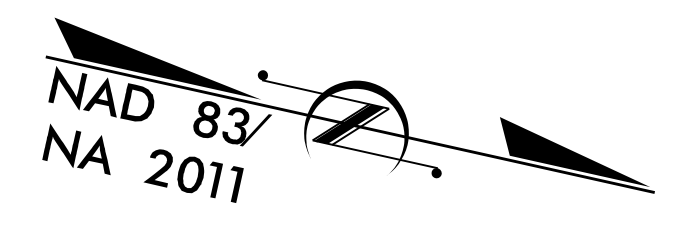

THIS PROJECT IS NOT WITHIN ANY MUNICIPAL BOUNDARIES.

DOCUMENT NOT CONSIDERED FINAL
UNLESS ALL SIGNATURES COMPLETED

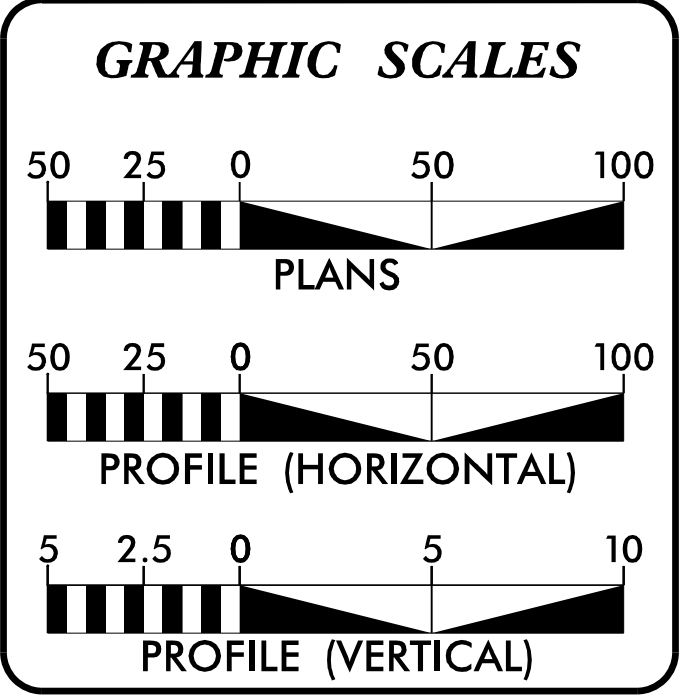

INDEX OF SHEETS

| SHEET NO.: | DESCRIPTION: |
|----------------|-----------------------------|
| UC-1 | TITLE SHEET |
| UC-2 | UTILITY SYMBOLOGY |
| UC-3 | NOTES |
| UC-3A | DETAILS |
| UC-4 THRU UC-6 | UTILITY CONSTRUCTION SHEETS |
| UC-7 | PROFILE SHEET |

WATER AND SEWER OWNERS ON PROJECT

| |
|---|
| A) WATER - CITY OF SANFORD |
| B) WATER - CHATHAM COUNTY |
| C) SANITARY SEWER - TOWN OF PITTSBORO (PROPOSED - TO BE INSTALLED BY OTHERS) |

PREPARED IN THE OFFICE OF:

DAVIS • MARTIN • POWELL
ENGINEERS & SURVEYORS **dmp**

8415 OLD PLANK RD., HIGH POINT, NC 27285
PHONE: (336)886-4821 FAX: (336)886-4458
WWW.DMP-INC.COM LICENSE: F-0245

| | |
|---------------------|-----------------------|
| Steve McKee, P.E. | CONSULTANT CONTACT #1 |
| Andy Larrick, P.E. | CONSULTANT CONTACT #2 |
| Randy McNeill, P.E. | CONSULTANT CONTACT #3 |

SEAL

11/30/2018 12:51:49 PM PST

**DIVISION OF HIGHWAYS
UTILITIES UNIT**
1555 MAIL SERVICES CENTER
RALEIGH, NC 27699-1555
PHONE (919) 707-6690
FAX (919) 250-4151

| | |
|---------------------|-----------------------------|
| Tucker Martin, P.E. | UTILITIES REGIONAL ENGINEER |
| Bernie Bungarner | UTILITIES ENGINEER |
| Dayton Martin | UTILITIES AREA COORDINATOR |
| Tanga Sampson | UTILITIES COORDINATOR |

5/14/99
11/30/2018 11:49 PM PST
11/30/2018 11:49 PM PST

UTILITY CONSTRUCTION

GENERAL NOTES:

1. THE PROPOSED UTILITY CONSTRUCTION SHALL MEET THE APPLICABLE REQUIREMENTS OF THE NC DEPARTMENT OF TRANSPORTATION'S "STANDARD SPECIFICATIONS FOR ROADS AND STRUCTURES" DATED JANUARY 2018.
2. THE EXISTING UTILITIES BELONG TO THE CITY OF SANFORD AND CHATHAM COUNTY.
3. ALL WATER LINES TO BE INSTALLED WITHIN COMPLIANCE OF THE RULES AND REGULATIONS OF THE NORTH CAROLINA DEPARTMENT OF ENVIRONMENTAL QUALITY, DIVISION OF WATER RESOURCES, PUBLIC WATER SUPPLY SECTION. ALL SEWER LINES TO BE INSTALLED WITHIN COMPLIANCE OF THE RULES AND REGULATIONS OF THE NORTH CAROLINA DEPARTMENT OF ENVIRONMENT QUALITY, DIVISION OF WATER RESOURCES, WATER QUALITY SECTION. PERFORM ALL WORK IN ACCORDANCE WITH THE APPLICABLE PLUMBING CODES.
4. THE UTILITY OWNER OWNS THE EXISTING UTILITY FACILITIES AND WILL OWN THE NEW UTILITY FACILITIES AFTER ACCEPTANCE BY THE DEPARTMENT. THE DEPARTMENT OWNS THE CONSTRUCTION CONTRACT AND HAS ADMINISTRATIVE AUTHORITY. COMMUNICATIONS AND DECISIONS BETWEEN THE CONTRACTOR AND UTILITY OWNER ARE NOT BINDING UPON THE DEPARTMENT OR THIS CONTRACT UNLESS AUTHORIZED BY THE ENGINEER. AGREEMENTS BETWEEN THE UTILITY OWNER AND CONTRACTOR FOR THE WORK THAT IS NOT PART OF THIS CONTRACT OR IS SECONDARY TO THIS CONTRACT ARE ALLOWED, BUT ARE NOT BINDING UPON THE DEPARTMENT.
5. PROVIDE ACCESS FOR THE DEPARTMENT PERSONNEL AND THE OWNER'S REPRESENTATIVES TO ALL PHASES OF CONSTRUCTION. NOTIFY DEPARTMENT PERSONNEL AND THE UTILITY OWNER TWO WEEKS PRIOR TO COMMENCEMENT OF ANY WORK AND ONE WEEK PRIOR TO SERVICE INTERRUPTION. KEEP UTILITY OWNERS' REPRESENTATIVES INFORMED OF WORK PROGRESS AND PROVIDE OPPORTUNITY FOR INSPECTION OF CONSTRUCTION AND TESTING.

6. THE PLANS DEPICT THE BEST AVAILABLE INFORMATION FOR THE LOCATION, SIZE, AND TYPE OF MATERIAL FOR ALL EXISTING UTILITIES. MAKE INVESTIGATIONS FOR DETERMINING THE EXACT LOCATION, SIZE, AND TYPE MATERIAL OF THE EXISTING FACILITIES AS NECESSARY FOR THE CONSTRUCTION OF THE PROPOSED UTILITIES AND FOR AVOIDING DAMAGE TO EXISTING FACILITIES. REPAIR ANY DAMAGE INCURRED TO EXISTING FACILITIES TO THE ORIGINAL OR BETTER CONDITION AT NO ADDITIONAL COST TO THE DEPARTMENT.
7. MAKE FINAL CONNECTIONS OF THE NEW WORK TO THE EXISTING SYSTEM WHERE INDICATED ON THE PLANS, AS REQUIRED TO FIT THE ACTUAL CONDITIONS, OR AS DIRECTED.
8. MAKE CONNECTIONS BETWEEN EXISTING AND PROPOSED UTILITIES AT TIMES MOST CONVENIENT TO THE PUBLIC, WITHOUT ENDANGERING THE UTILITY SERVICE, AND IN ACCORDANCE WITH THE UTILITY OWNER'S REQUIREMENTS. MAKE CONNECTIONS ON WEEKENDS, AT NIGHT, AND ON HOLIDAYS IF NECESSARY.
9. ALL UTILITY MATERIALS SHALL BE APPROVED PRIOR TO DELIVERY TO THE PROJECT. SEE 1500-7, " SUBMITTALS AND RECORDS" IN SECTION 1500 OF THE STANDARD SPECIFICATIONS.

PROJECT SPECIFIC NOTES:

1. UNLESS OTHERWISE NOTED, FOR PROPOSED WATER MAINS AND SEWER MAINS 4" AND LARGER, PIPE AND FITTINGS SHALL BE DUCTILE IRON, PC 350.
2. WATER LINE VALVES SHALL BE RESILIENT -SEAT GATE VALVES CONFORMING TO ANSI/AWWA C509, RATED FOR 200 PSI MINIMUM WORKING PRESSURE.

LIST OF STANDARD DRAWINGS

- 1515.01 WATER METER
- 1515.02 FIRE HYDRANT

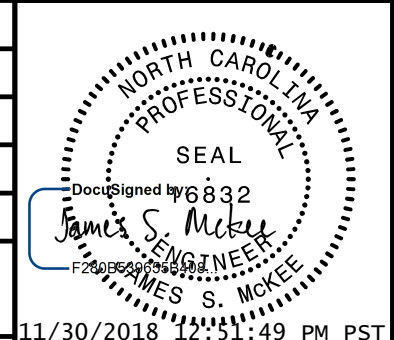
| | |
|--|--|
| PROJECT REFERENCE NO. | SHEET NO. |
| B-4968 | UC-3 |
| DESIGNED BY: DMP |  |
| DRAWN BY: DMP | |
| CHECKED BY: DMP | |
| APPROVED BY: | |
| REVISED: | |
| NORTH CAROLINA DEPARTMENT OF TRANSPORTATION | 11/30/2018 11:49 PM PST |
| UTILITIES ENGINEERING SEC. PHONE: (919) 707-6690 FAX: (919) 250-4151 | UTILITY CONSTRUCTION PLANS ONLY |

UTILITY CONSTRUCTION

DOCUMENT NOT CONSIDERED FINAL UNLESS ALL SIGNATURES COMPLETED

5/14/99

PROJECT TYPICAL DETAILS

| | |
|--|---------------------------------|
| PROJECT REFERENCE NO. | SHEET NO. |
| B-4968 | UC-3A |
| DESIGNED BY: DMP | |
| DRAWN BY: DMP | |
| CHECKED BY: DMP | |
| APPROVED BY: | |
| REVISED: | |
| NORTH CAROLINA DEPARTMENT OF TRANSPORTATION | 11/30/2018 12:51:49 PM PST |
| UTILITIES ENGINEERING SEC. PHONE: (919) 707-6690 FAX: (919) 250-4151 | UTILITY CONSTRUCTION PLANS ONLY |

UTILITY CONSTRUCTION

DOCUMENT NOT CONSIDERED FINAL UNLESS ALL SIGNATURES COMPLETED

| NOMINAL PIPE SIZE (INCHES) | TRENCH WIDTH (INCHES) | NOMINAL PIPE SIZE (INCHES) | TRENCH WIDTH (INCHES) |
|----------------------------|-----------------------|----------------------------|-----------------------|
| 4 | 28 | 20 | 44 |
| 6 | 30 | 24 | 48 |
| 8 | 32 | 30 | 54 |
| 10 | 34 | 36 | 60 |
| 12 | 36 | 42 | 66 |
| 14 | 38 | 48 | 72 |
| 16 | 40 | 54 | 78 |
| 18 | 42 | | |

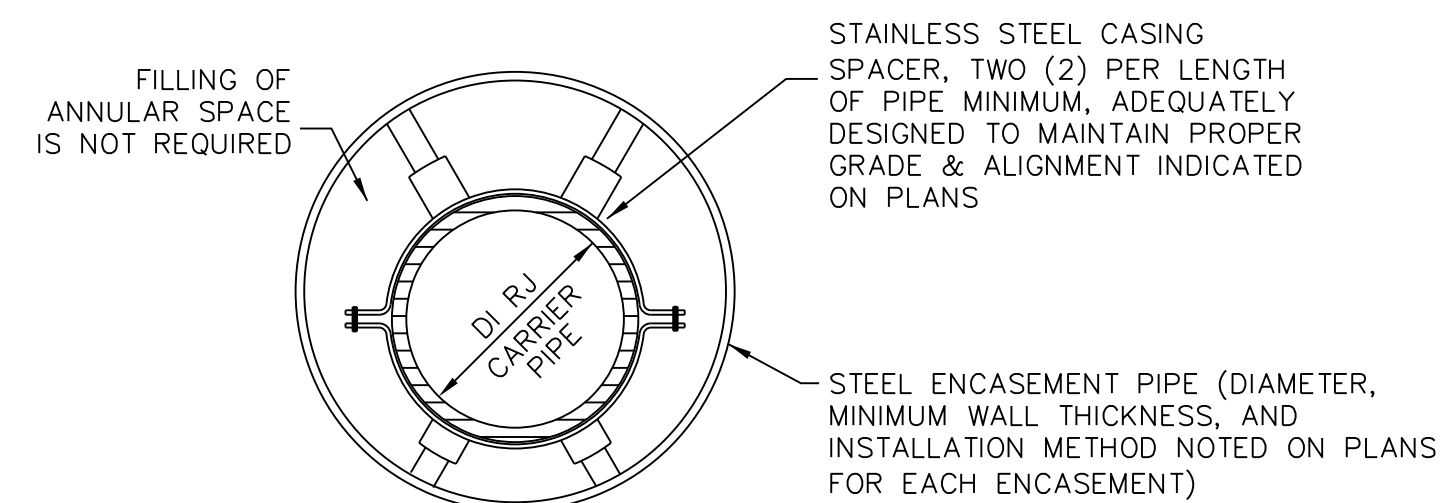

- NOTES:
 1. ENCLOSE ENDS WITH BRICK MASONRY.
 2. PROVIDE 1" WEEP HOLE AT LOW END OF ENCASEMENT.

TYPICAL ENCASEMENT PIPE SECTION
N.T.S.

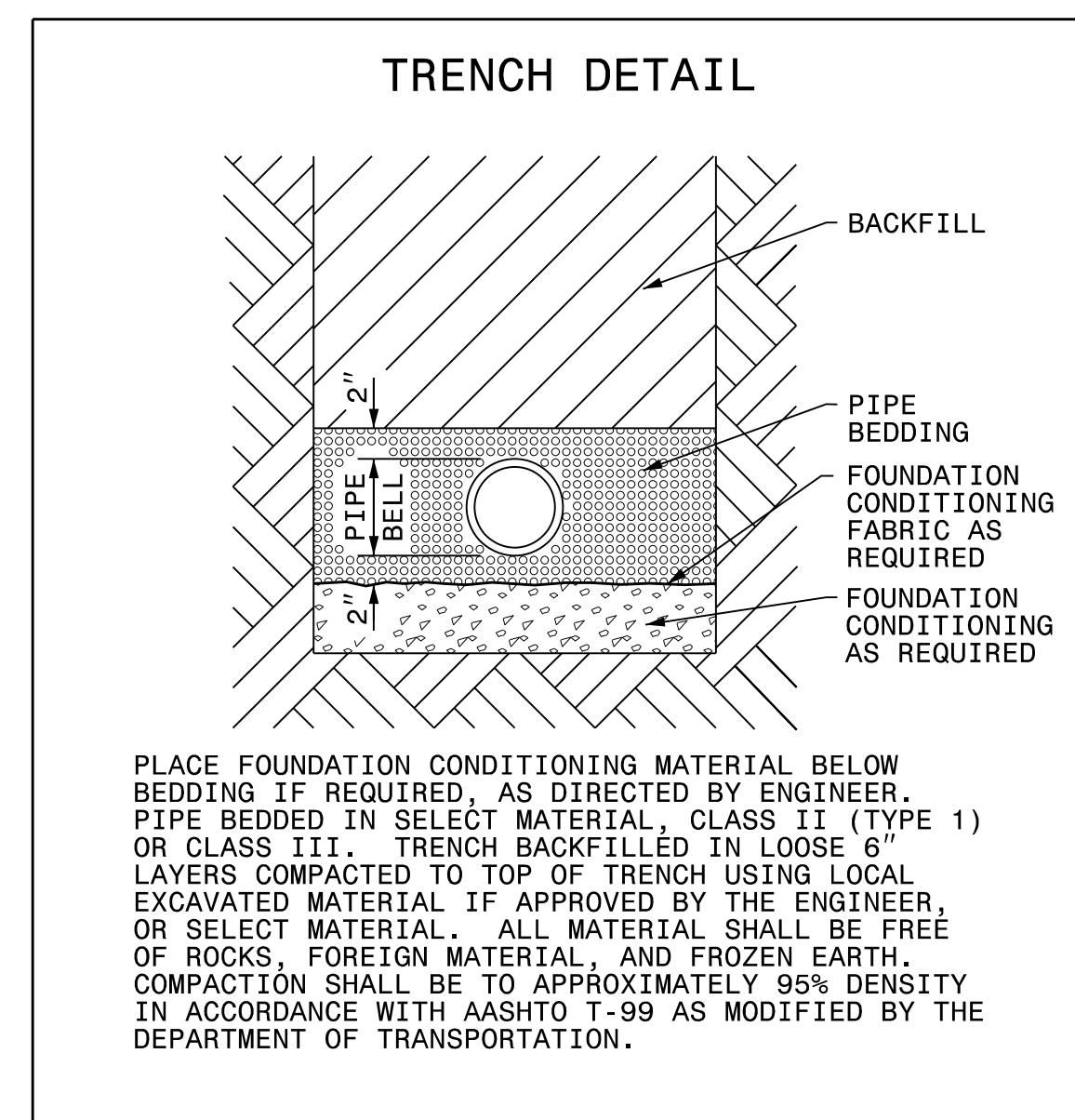

5/14/19

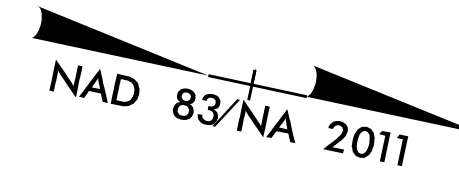
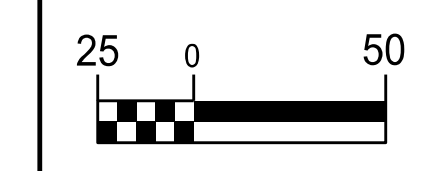

| | |
|---------------------------------|---|
| PROJECT REFERENCE NO. | SHEET NO. |
| B-4968 | UC-4 |
| DESIGNED BY: DMP | |
| DRAWN BY: DMP | |
| CHECKED BY: DMP | |
| APPROVED BY: | |
| REVISD: | NORTH CAROLINA DEPARTMENT OF TRANSPORTATION UTILITIES ENGINEERING SEC. PHONE: (919) 707-6690 FAX: (919) 250-4151 |
| UTILITY CONSTRUCTION PLANS ONLY | |

UTILITY CONSTRUCTION

**DOCUMENT NOT CONSIDERED FINAL
UNLESS ALL SIGNATURES COMPLETED**

-L- CURVE DATA

| | | |
|-------------------------------------|-------------------------------------|-------------------------------------|
| PI Sta 11+69.19 | PI Sta 18+08.77 | PI Sta 27+30.66 |
| $\Delta = 1^{\circ} 24' 26.8" (LT)$ | $\Delta = 9^{\circ} 46' 38.4" (LT)$ | $\Delta = 3^{\circ} 49' 37.3" (RT)$ |
| $D = 0^{\circ} 24' 57.5"$ | $D = 1^{\circ} 02' 30.3"$ | $D = 1^{\circ} 02' 30.3"$ |
| $L = 338.35'$ | $L = 938.56'$ | $L = 367.37'$ |
| $T = 169.19'$ | $T = 470.42'$ | $T = 183.75'$ |
| $R = 13,774.16'$ | $R = 5,500.00'$ | $R = 5,500.00'$ |
| $SE = EXIST.$ | $SE = 0.03$ | $SE = 0.03$ |
| | $RO = 8'$ | $RO = 8'$ |

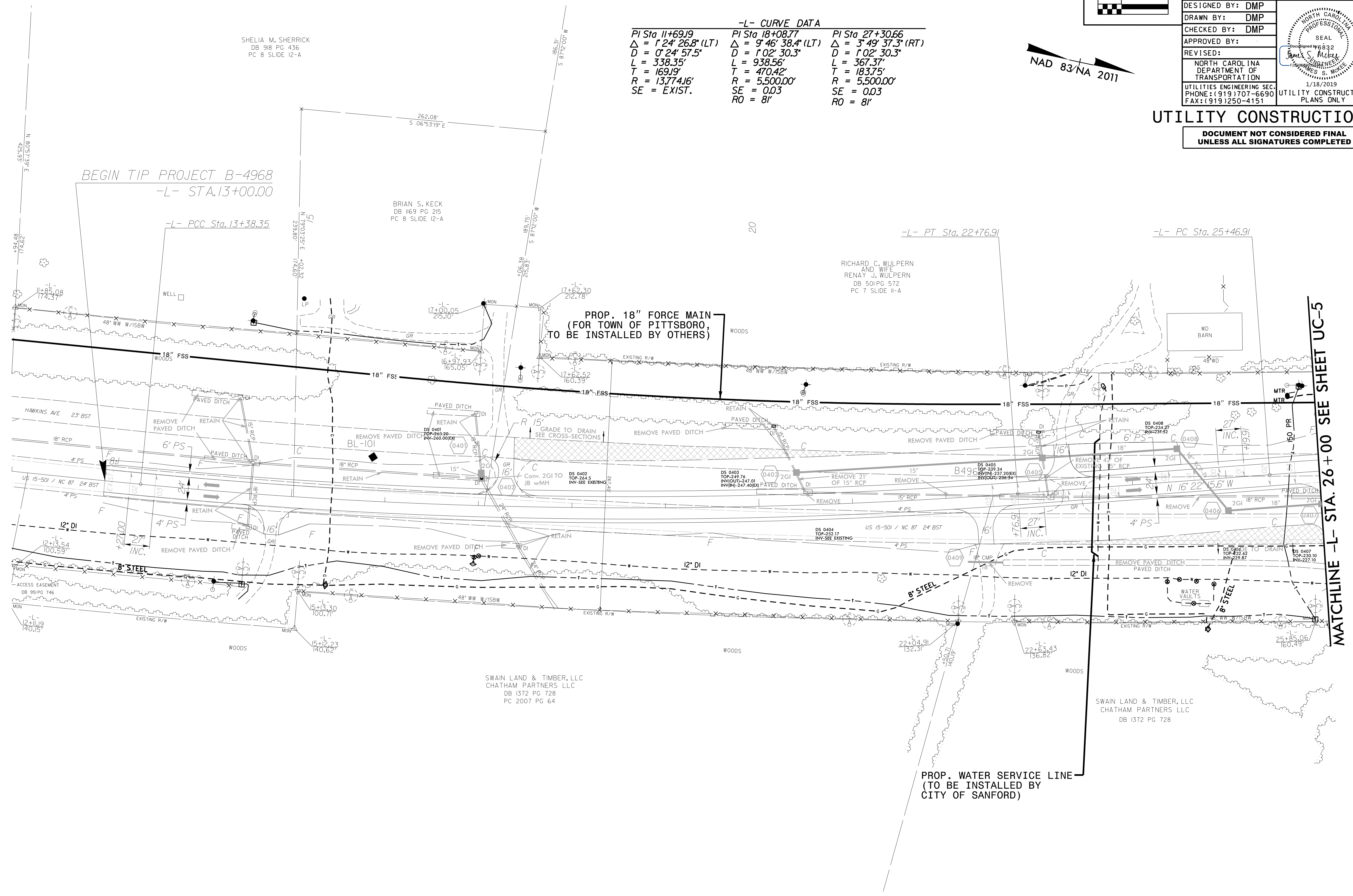

MATCHLINE -L- STA. 26 + 00 SEE SHEET UC-5

5/14/19

RELATIONSHIP OF BRIDGE TO PROPOSED PAVEMENT

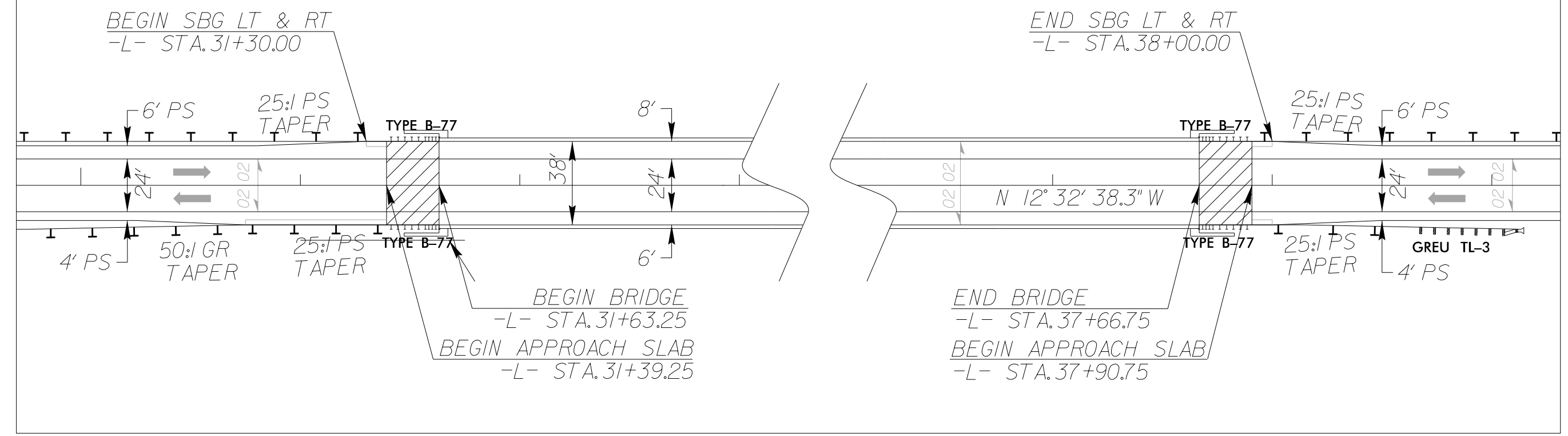

-L- CURVE DATA

| | |
|-------------------------------------|--------------------------------------|
| PI Sta 27+30.66 | PI Sta 50+75.26 |
| $\Delta = 3^{\circ} 49' 37.3" (RT)$ | $\Delta = 20^{\circ} 05' 46.5" (RT)$ |
| $D = 1^{\circ} 02' 30.3"$ | $D = 0^{\circ} 54' 34.0"$ |
| $L = 367.37'$ | $L = 2,209.70'$ |
| $T = 183.75'$ | $T = 1,116.32'$ |
| $R = 5,500.00'$ | $R = 6,300.00'$ |
| $SE = 0.03$ | $SE = 0.03$ |
| $RO = 81'$ | $RO = 81'$ |

| | |
|--|--------------------------|
| PROJECT REFERENCE NO. B-4968 | SHEET NO. UC-5 |
| DESIGNED BY: DMP | |
| DRAWN BY: DMP | |
| CHECKED BY: DMP | |
| APPROVED BY: | |
| REVISED: | |
| NORTH CAROLINA DEPARTMENT OF TRANSPORTATION UTILITIES ENGINEERING SEC. PHONE: (919) 707-6690 FAX: (919) 250-4151 UTILITY CONSTRUCTION PLANS ONLY | |

- TEMPORARY SHORING LOCATIONS (SEE TMP)**
- L- STA. 31+00± TO STA. 31+75±, 25' RT
 - L- STA. 31+20± TO STA. 31+70±, 50' RT
 - L- STA. 37+55± TO STA. 38+35±, 25' RT
 - L- STA. 36+65± TO STA. 37+95±, 50' RT

UTILITY CONSTRUCTION
DOCUMENT NOT CONSIDERED FINAL UNLESS ALL SIGNATURES COMPLETED

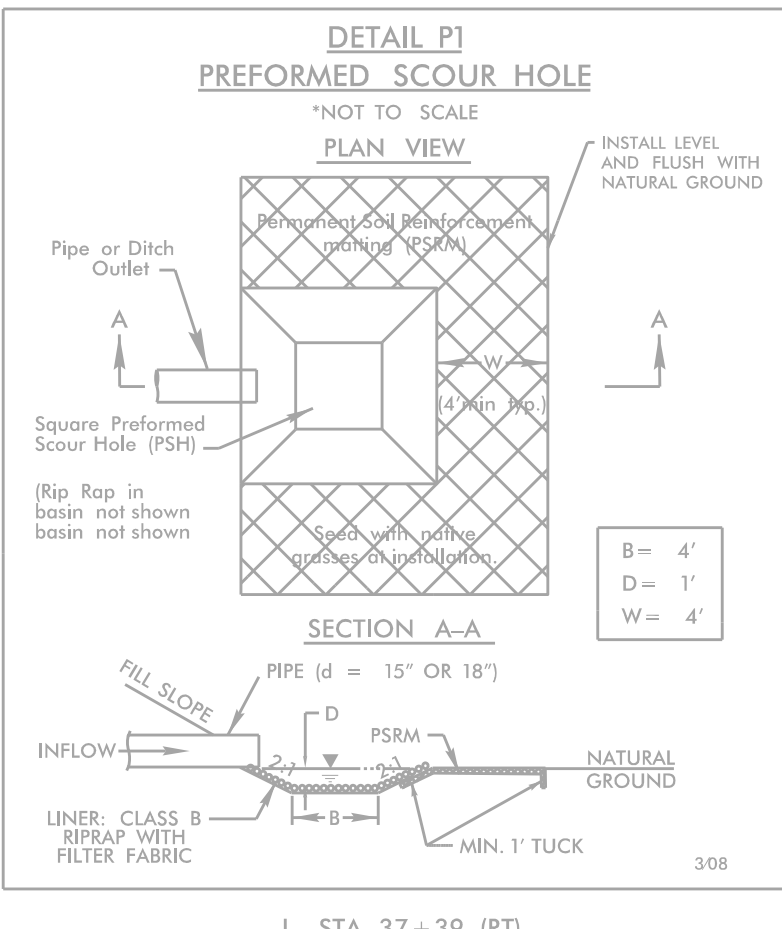
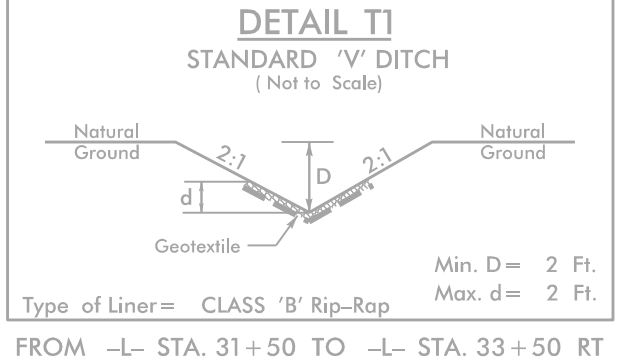
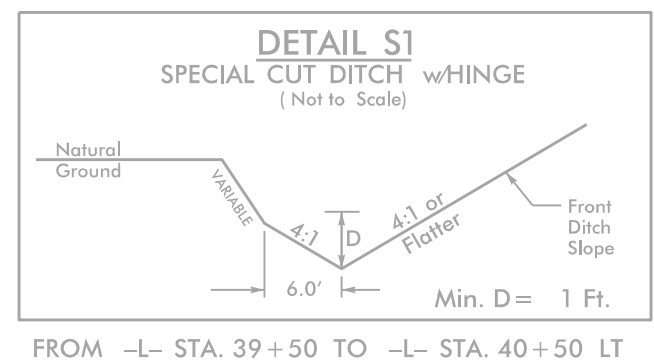
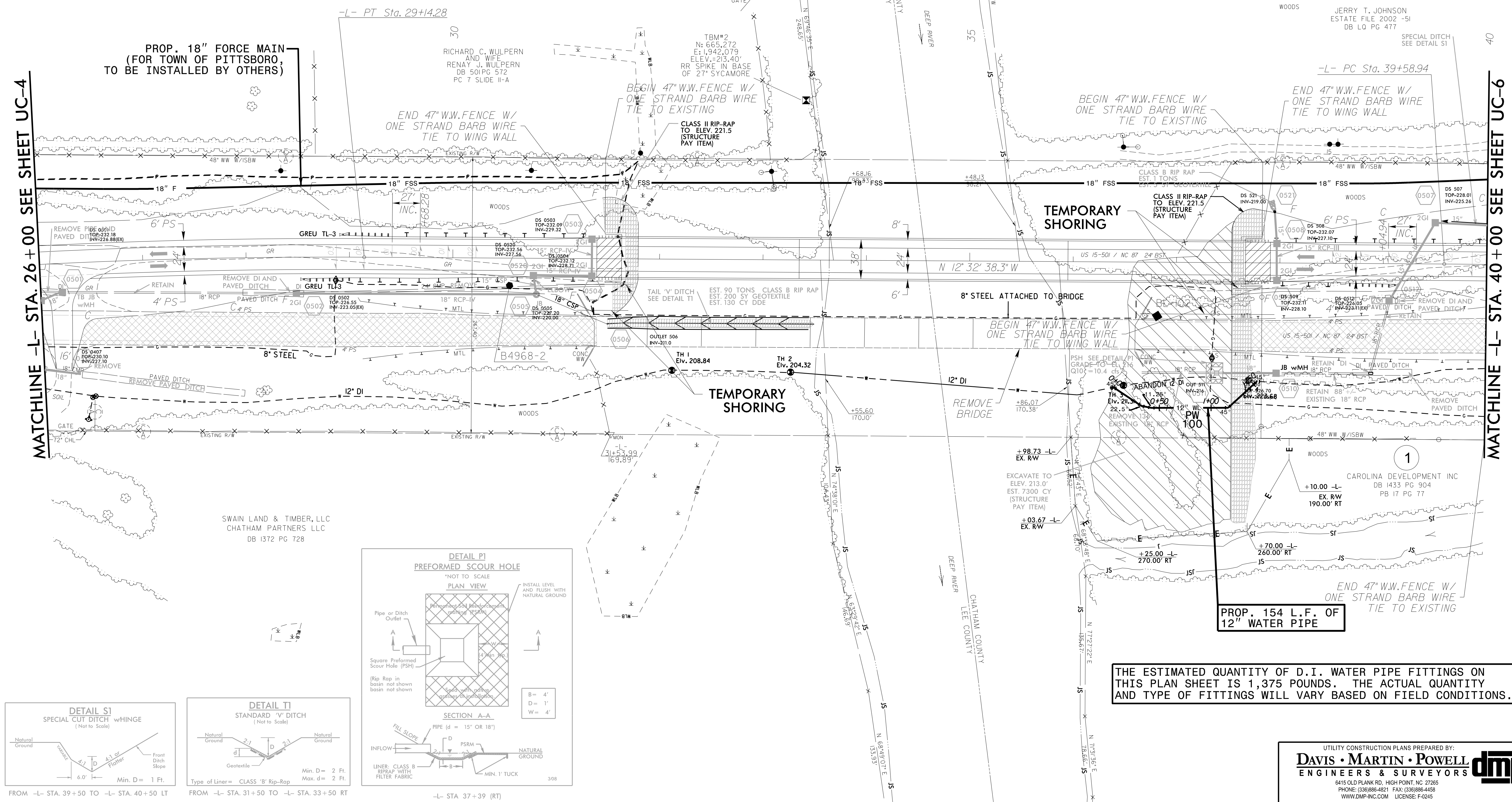

THE ESTIMATED QUANTITY OF D.I. WATER PIPE FITTINGS ON THIS PLAN SHEET IS 1,375 POUNDS. THE ACTUAL QUANTITY AND TYPE OF FITTINGS WILL VARY BASED ON FIELD CONDITIONS.

UTILITY CONSTRUCTION PLANS PREPARED BY:
DAVIS • MARTIN • POWELL
 ENGINEERS & SURVEYORS

6415 OLD PLANK RD., HIGH POINT, NC 27265
 PHONE: (336) 886-4821 FAX: (336) 886-4458
 WWW.DMP-INC.COM LICENSE: F-0245

5/14/99

REVISIONS

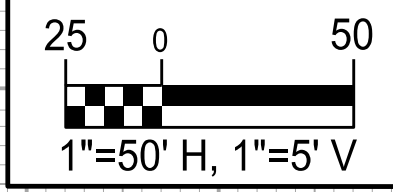

| | |
|--|--|
| PROJECT REFERENCE NO. B-4968 | SHEET NO. UC-7 |
| DESIGNED BY: APL | |
| DRAWN BY: RDL | |
| CHECKED BY: APL | |
| APPROVED BY: | |
| REVISER: | NORTH CAROLINA DEPARTMENT OF TRANSPORTATION 11/30/2018 11:49 PM PST |
| UTILITIES ENGINEERING SEC. PHONE: (919) 707-6690 FAX: (919) 250-4151 | UTILITY CONSTRUCTION PLANS ONLY |

UTILITY CONSTRUCTION

**DOCUMENT NOT CONSIDERED FINAL
UNLESS ALL SIGNATURES COMPLETED**

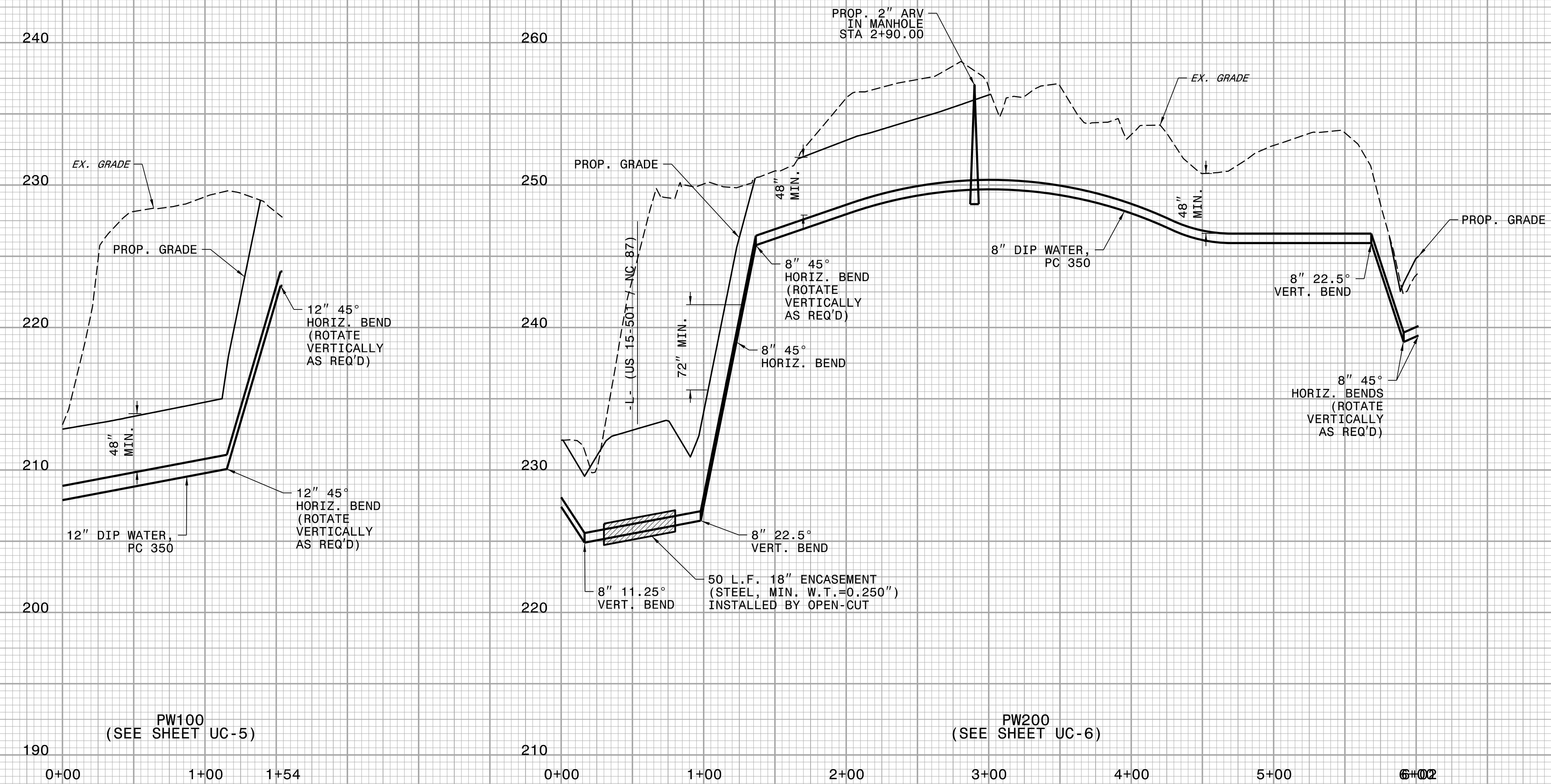

PW100
(SEE SHEET UC-5)

PW200
(SEE SHEET UC-6)