

**This electronic collection of documents is provided  
for the convenience of the user  
and is Not a Certified Document –**

**The documents contained herein were originally issued  
and sealed by the individuals whose names and license  
numbers appear on each page, on the dates appearing  
with their signature on that page.**

**This file or an individual page  
shall not be considered a certified document.**



150 140 130 120 110 100 90 80 70 60 50 40 30 20 10 0 10 20 30 40 50 60 70 80 90 100 110 120 130 140 150

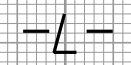
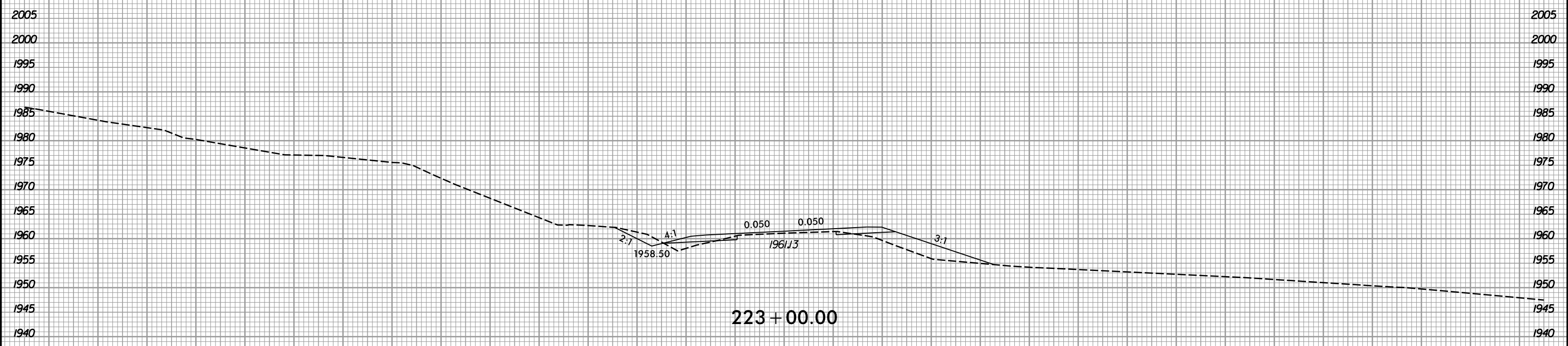
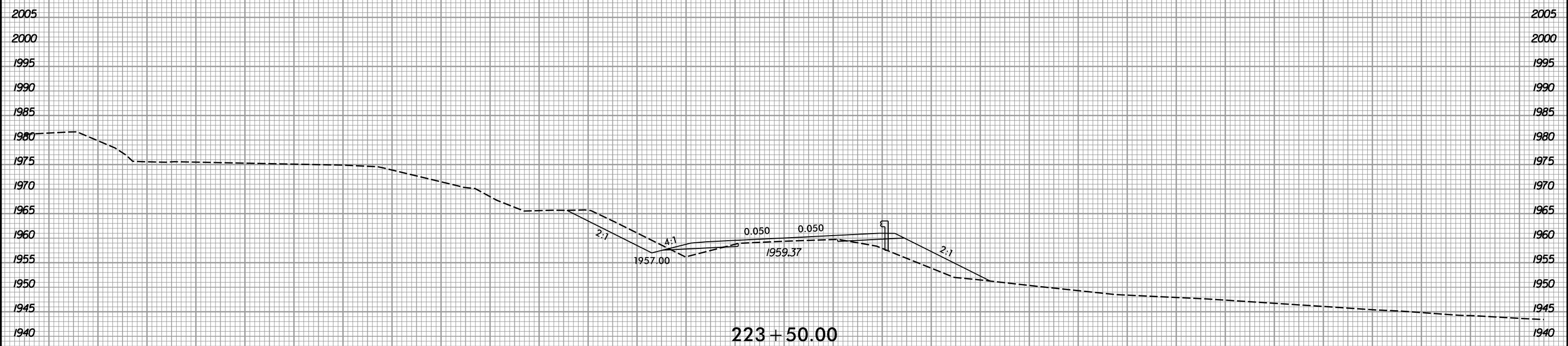

6/23/16



PROJ. REFERENCE NO.  
R-5742

SHEET NO.  
X-138

150 140 130 120 110 100 90 80 70 60 50 40 30 20 10 0 10 20 30 40 50 60 70 80 90 100 110 120 130 140 150

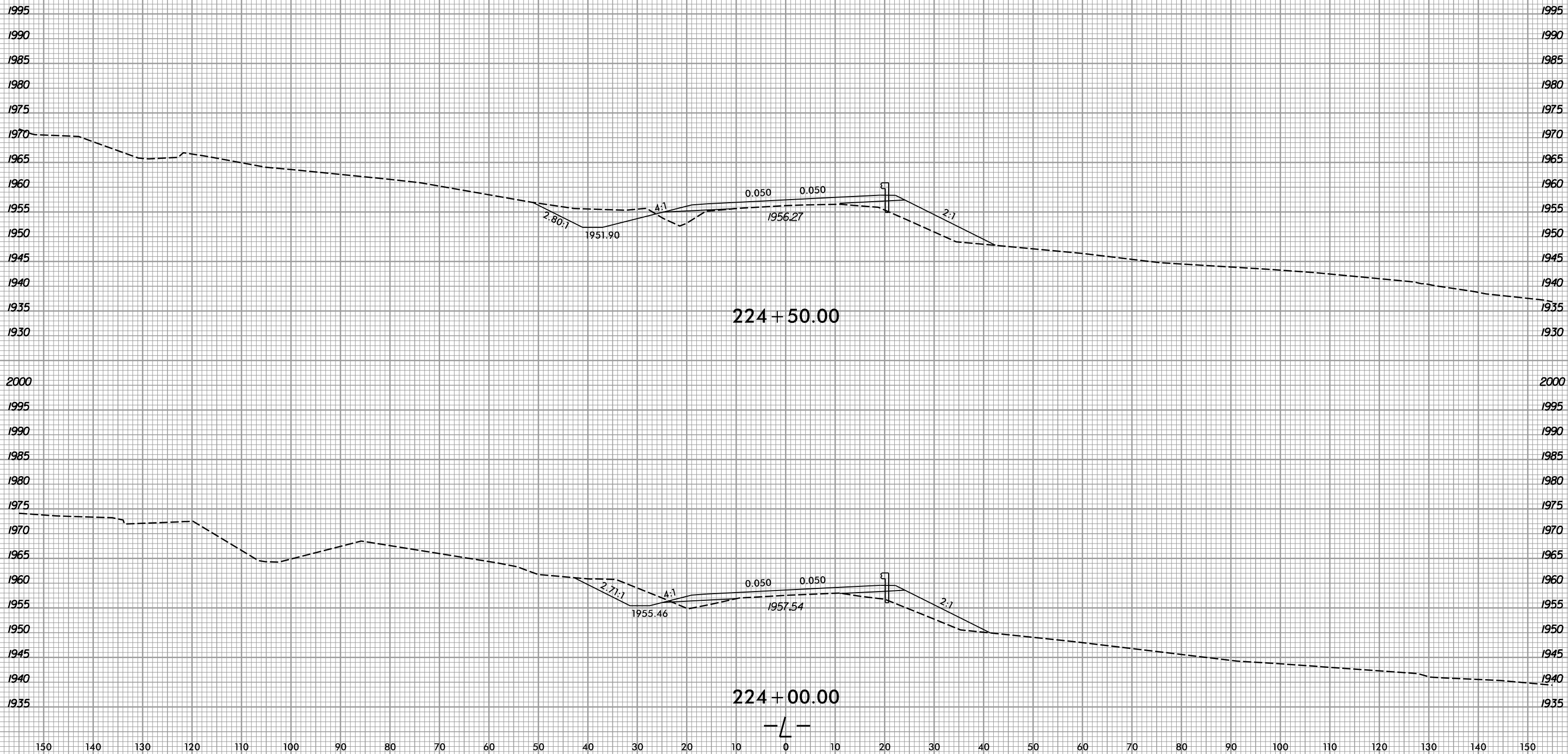

I:\14\2018  
R:\Roadway\Xsc\18-R-5742-Rdy.L\_xpl.dgn  
gpr/ice

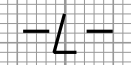
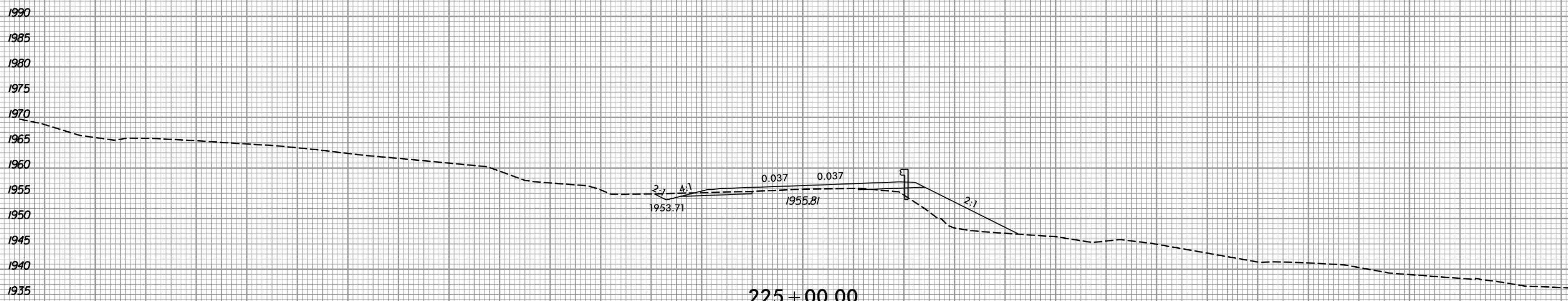
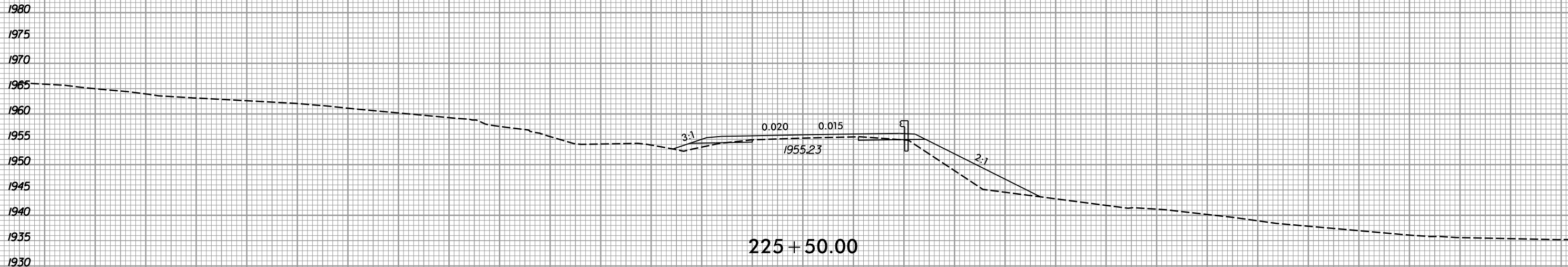
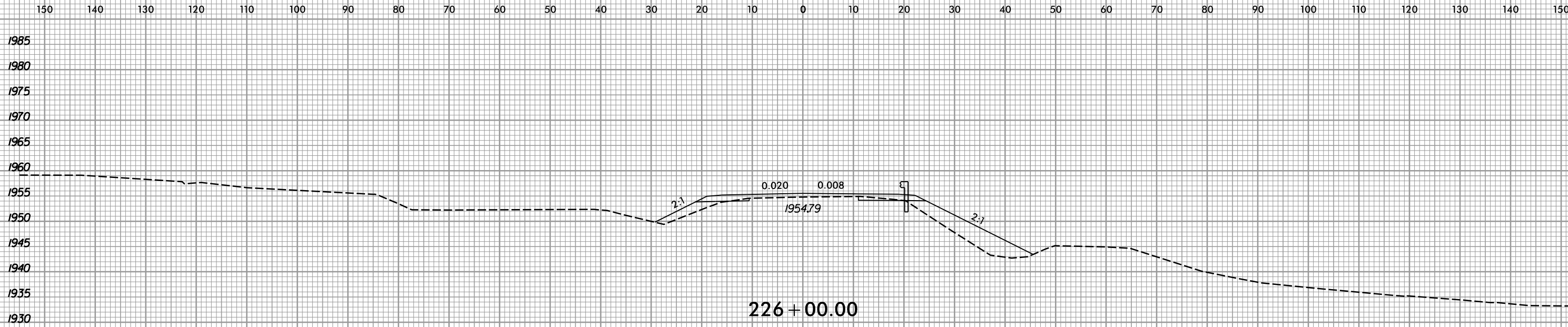

6/23/16



PROJ. REFERENCE NO.  
R-5742

SHEET NO.  
X-140

150 140 130 120 110 100 90 80 70 60 50 40 30 20 10 0 10 20 30 40 50 60 70 80 90 100 110 120 130 140 150

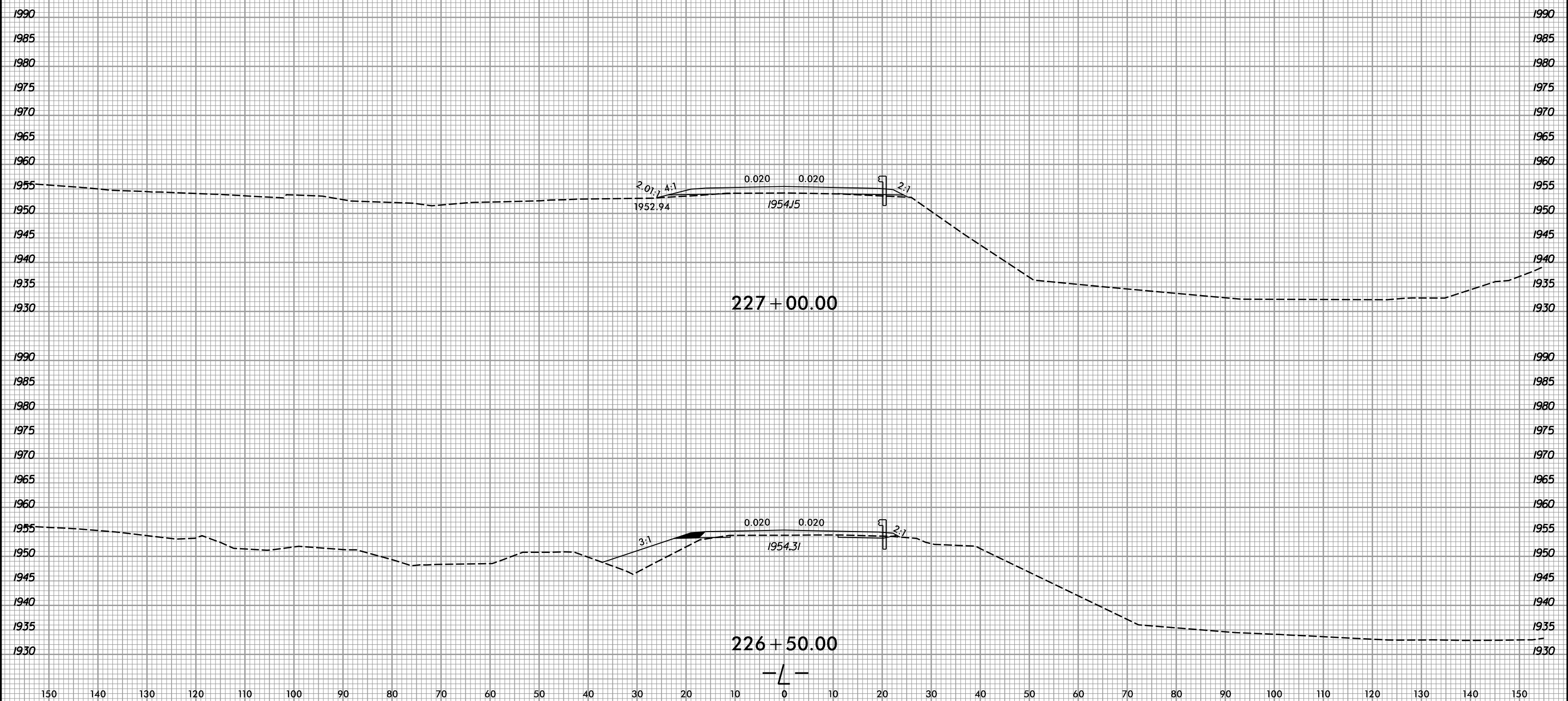

I:\14\2018  
R:\Roadway\Xsc\14-R-5742-Rdy.L\_xpl.dgn  
gpr/ice

6/23/16



PROJ. REFERENCE NO.  
R-5742

SHEET NO.  
X-141

150 140 130 120 110 100 90 80 70 60 50 40 30 20 10 0 10 20 30 40 50 60 70 80 90 100 110 120 130 140 150

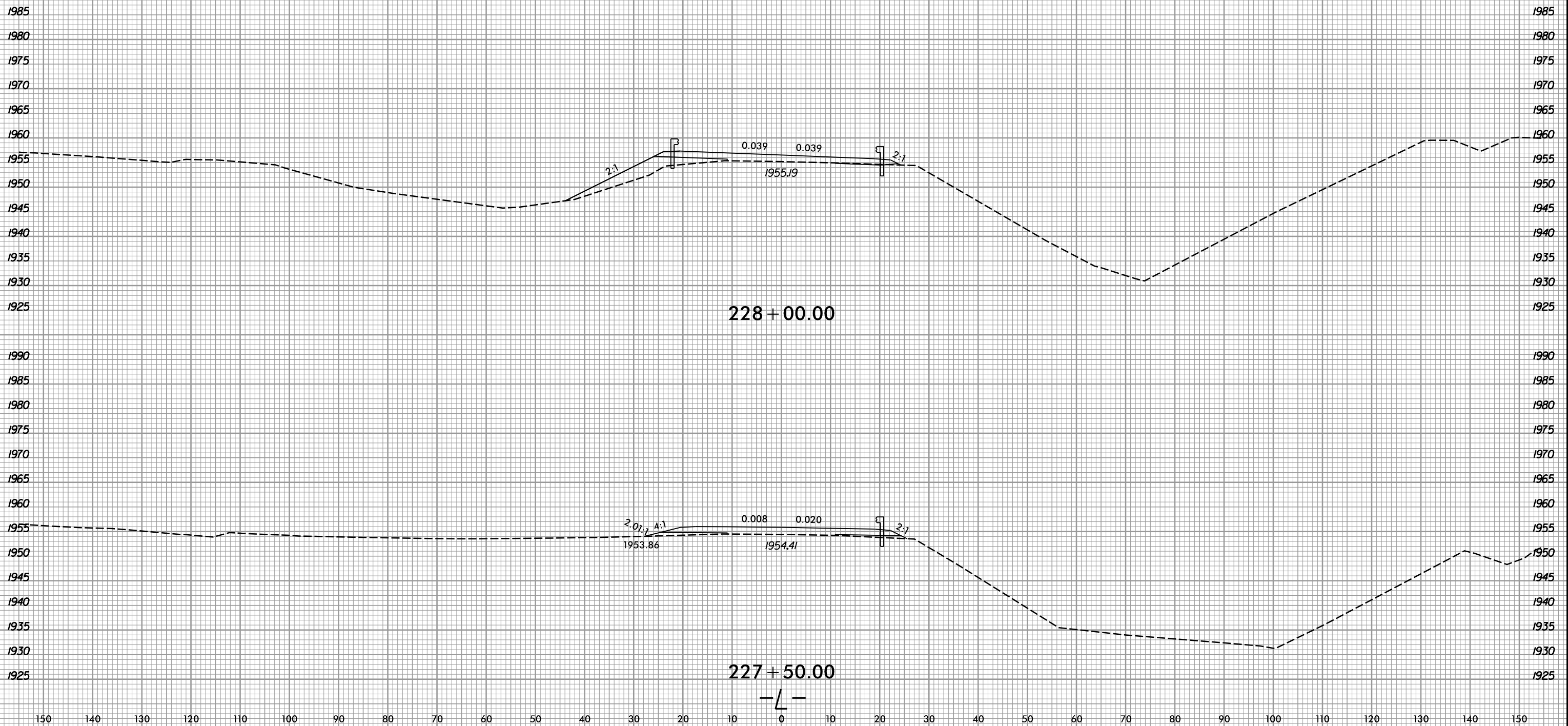

I:\14\2018  
R:\Roadway\Xsc\18-5742.Rdy.L\_xpl.dgn  
gpr/ice

6/23/16



PROJ. REFERENCE NO.	SHEET NO.
R-5742	X-142

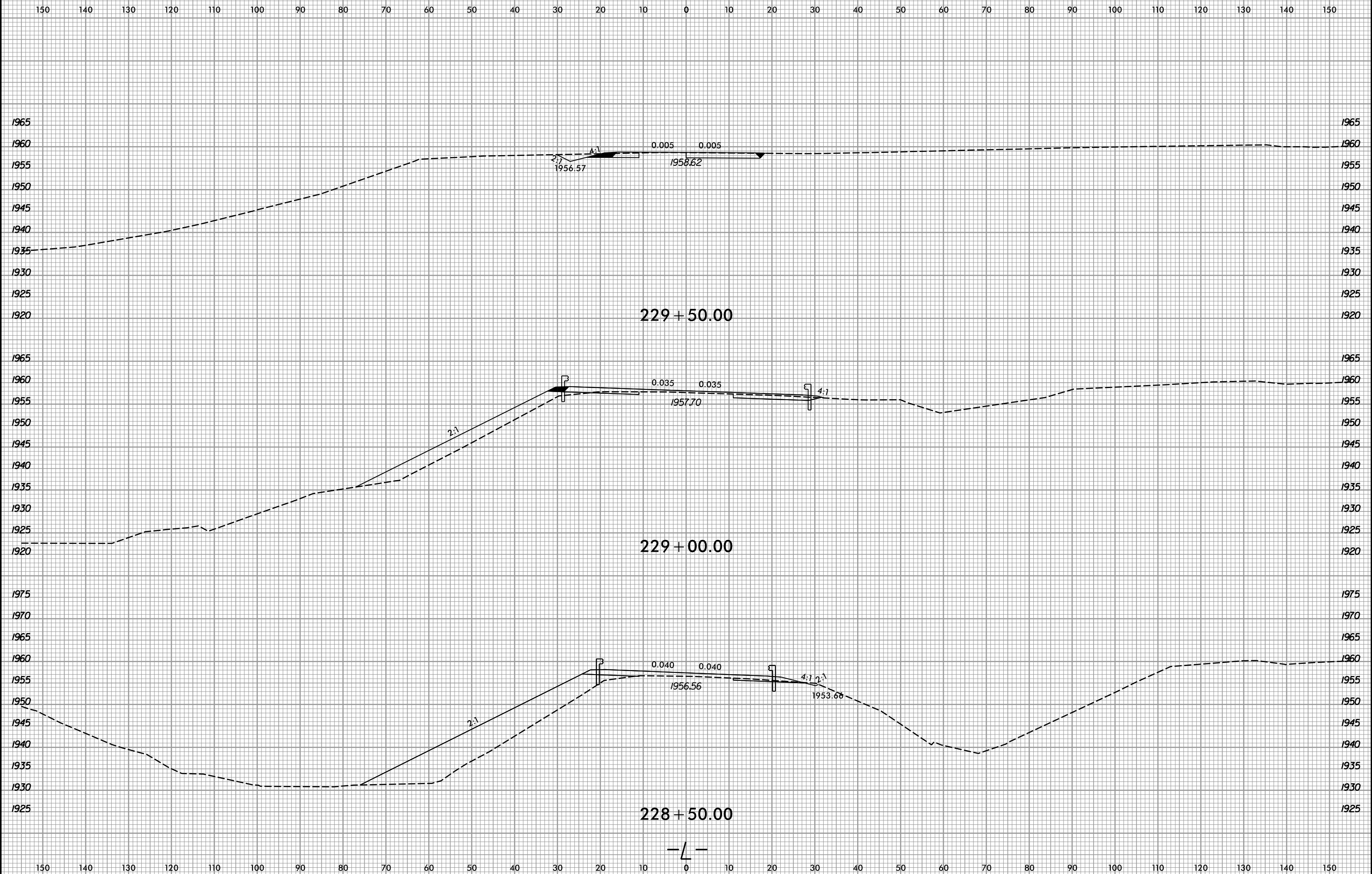

I:\14\2018  
R:\Roadway\Xsc\14-5742-Rdy-L\_xpl.dgn  
gpr/ice

6/23/16



PROJ. REFERENCE NO.  
R-5742

SHEET NO.  
X-143

150 140 130 120 110 100 90 80 70 60 50 40 30 20 10 0 10 20 30 40 50 60 70 80 90 100 110 120 130 140 150

1970  
1965  
1960  
1955  
1950  
1945  
1965  
1960  
1955  
1950  
1945

1970  
1965  
1960  
1955  
1950  
1945  
1965  
1960  
1955  
1950  
1945

2.01:1 4.02:1 0.003 0.003 4.01:1 2:1

1953.54 1955.09

11 + 00.00

4.06:1 0.009 0.009 4.01:1 2.01:1

1953.49 1952.32

10 + 50.00

-Y/-

150 140 130 120 110 100 90 80 70 60 50 40 30 20 10 0 10 20 30 40 50 60 70 80 90 100 110 120 130 140 150

I2/14/2018  
R:\Roadway\Xsc\R-5742\_Rdy\_Y1\_xp1.dgn  
gpr/ice





150 140 130 120 110 100 90 80 70 60 50 40 30 20 10 0 10 20 30 40 50 60 70 80 90 100 110 120 130 140 150

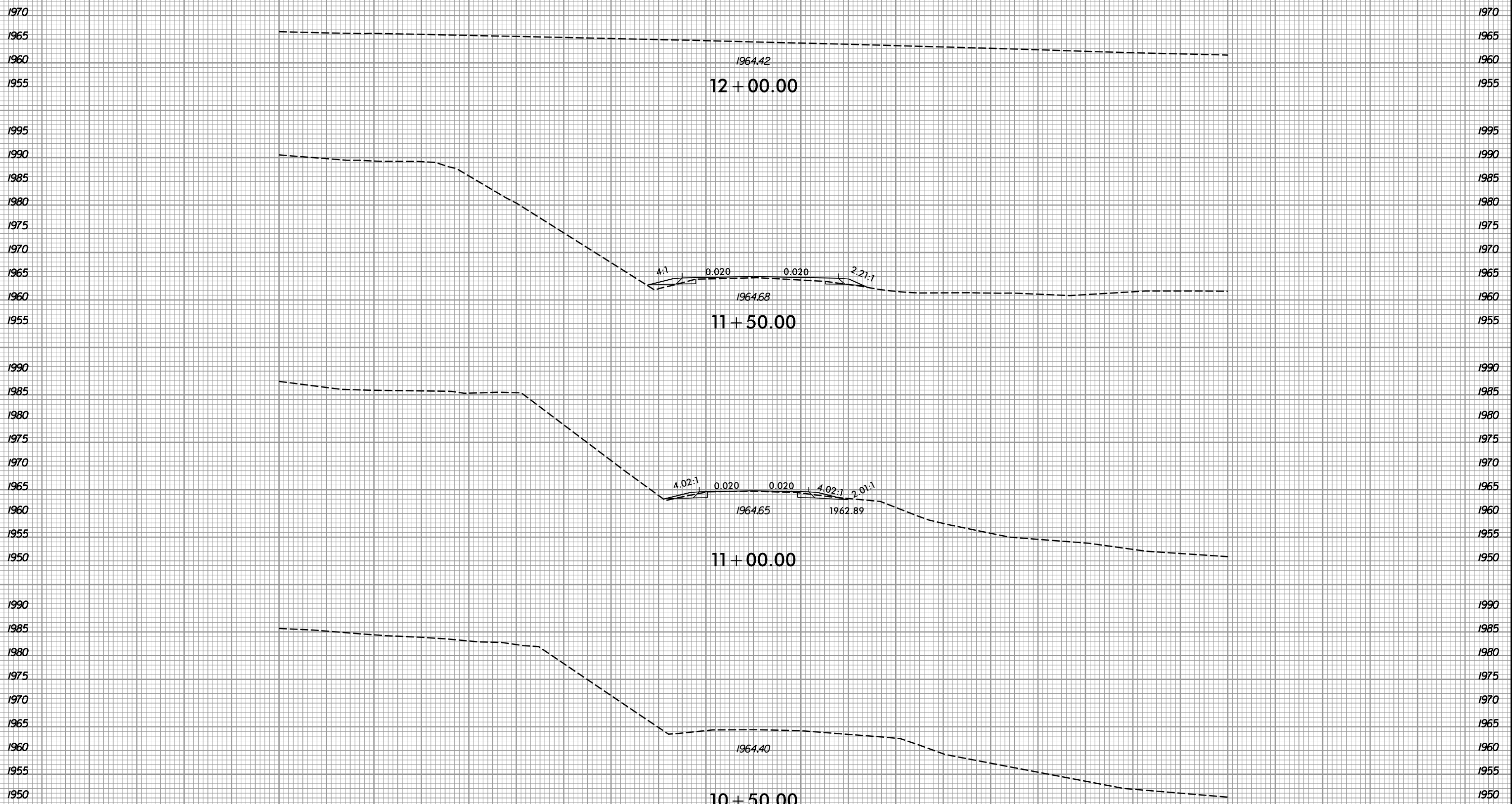

150 140 130 120 110 100 90 80 70 60 50 40 30 20 10 0 10 20 30 40 50 60 70 80 90 100 110 120 130 140 150

-Y2-

6/23/16

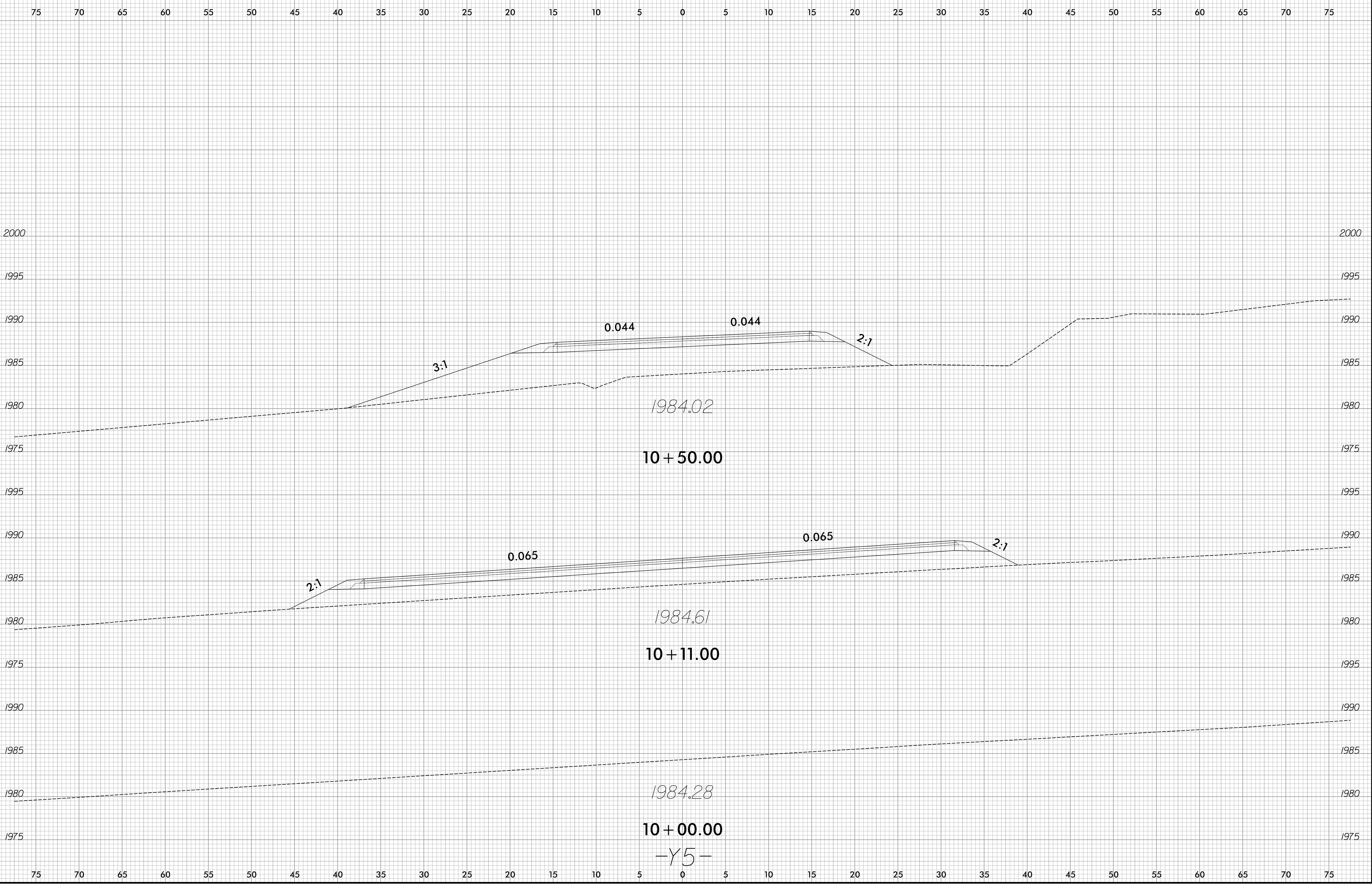

12/14/2018  
R:\Roadway\Xsc R-5742-Rdy-Y5\_xp.dgn  
gprlce

6/23/16

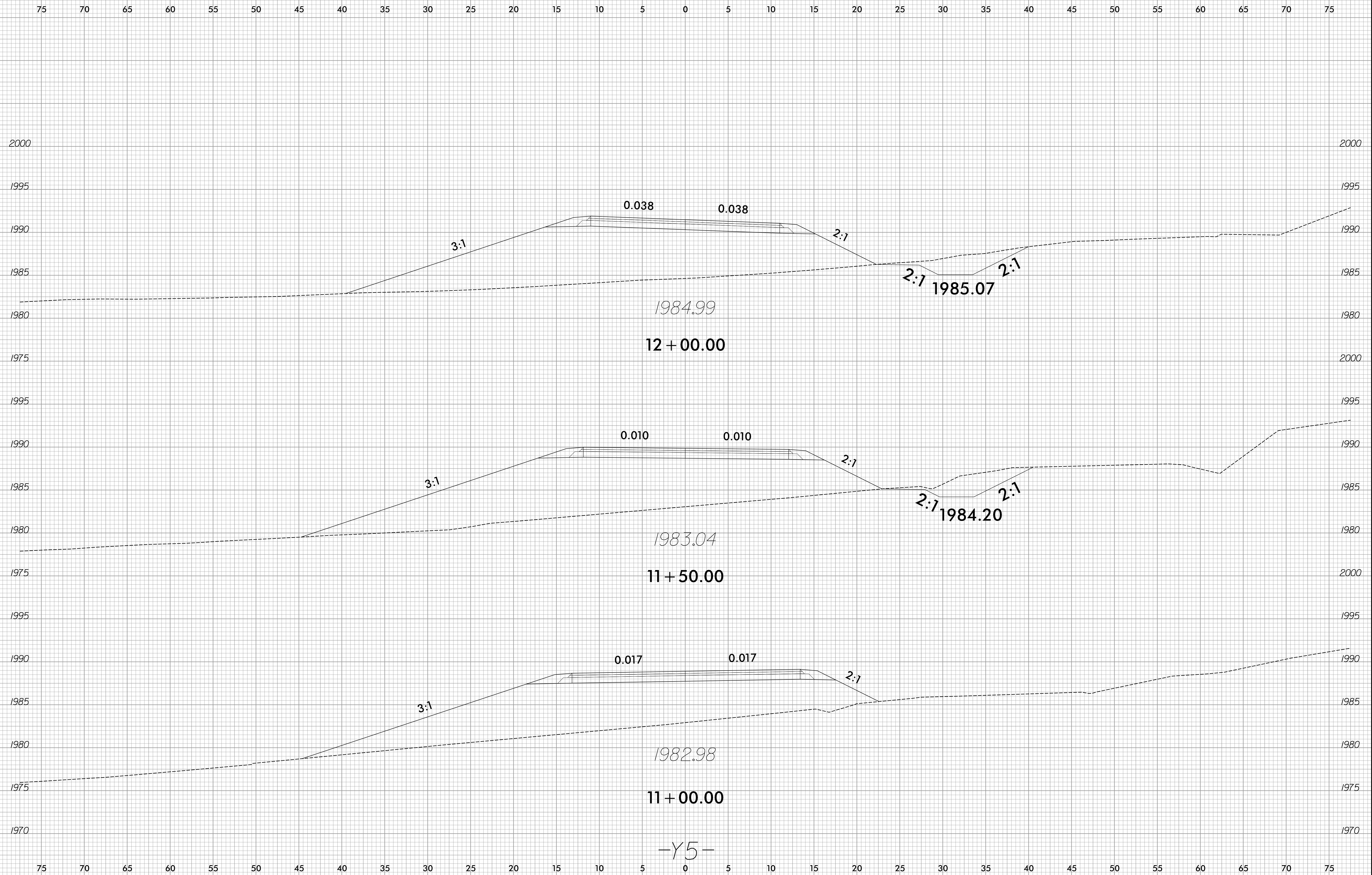

12/14/2018  
R:\Roadway\Xsc R-5742-Rdy-Y5\_xp1.dgn  
gprlce

6/23/16

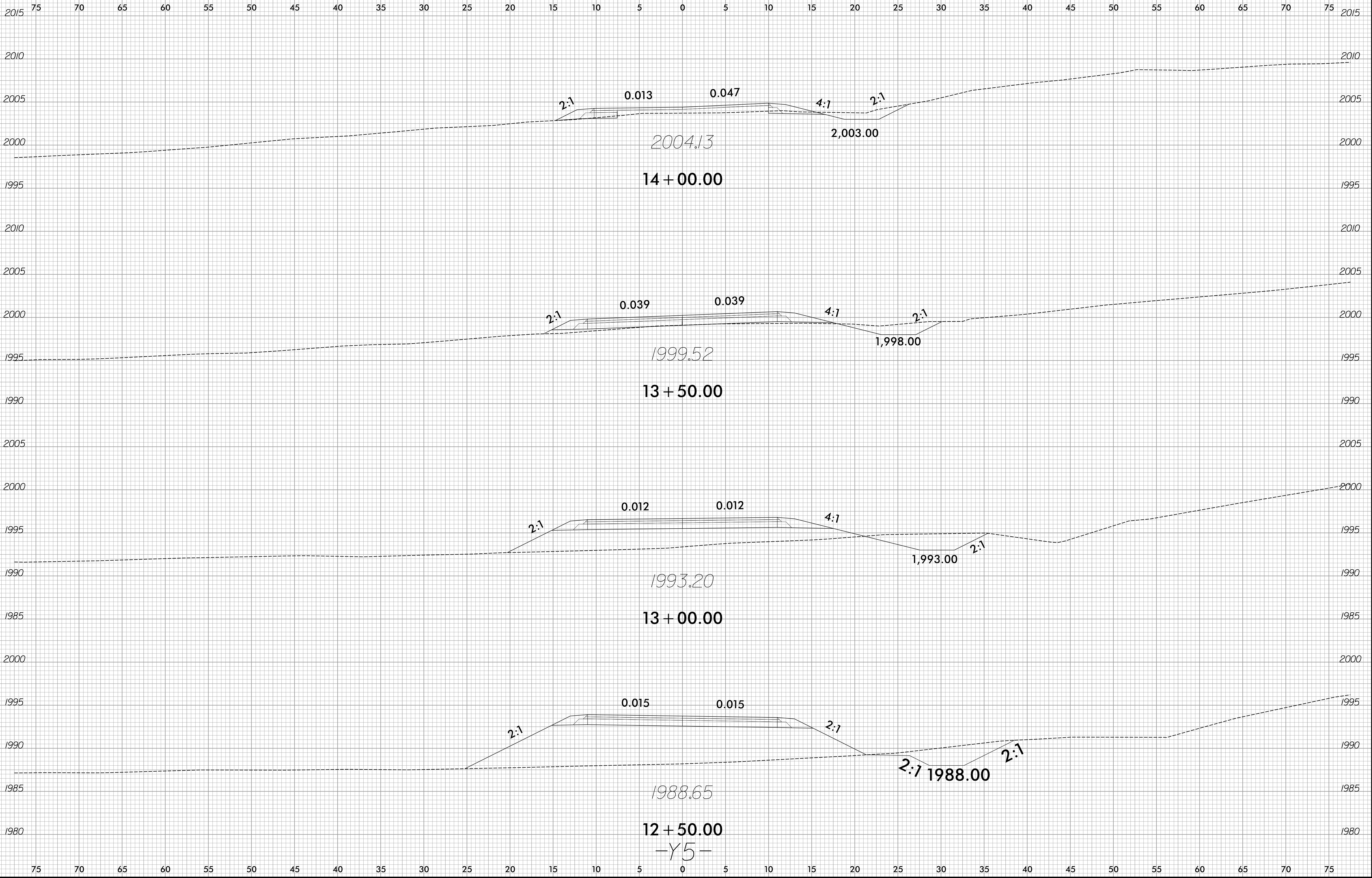

12/14/2018  
R:\Roadway\Xsec R-5742.Rdy-y5\_xp1.dgn  
gprlce

75 70 65 60 55 50 45 40 35 30 25 20 15 10 5 0 5 10 15 20 25 30 35 40 45 50 55 60 65 70 75

6/23/16

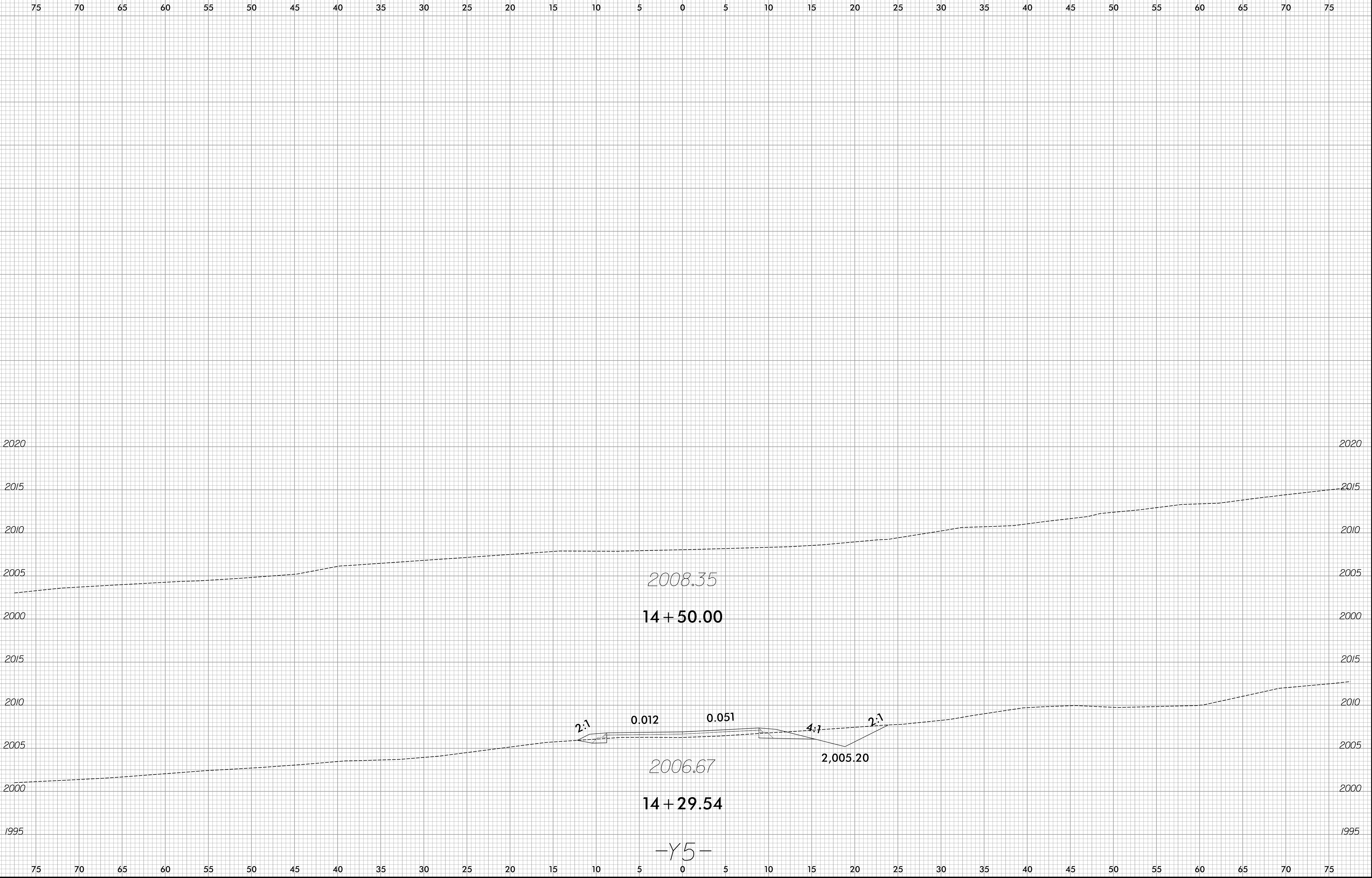

12/14/2018  
R:\Roadway\Xsec\R-5742-Fdy-Y5\_xp.dgn  
gprlce

-Y5-



150 140 130 120 110 100 90 80 70 60 50 40 30 20 10 0 10 20 30 40 50 60 70 80 90 100 110 120 130 140 150

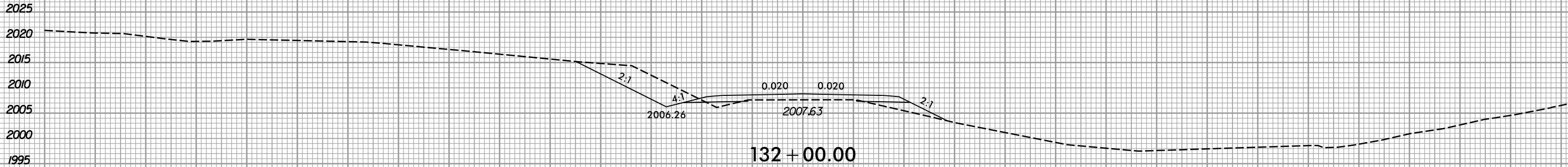
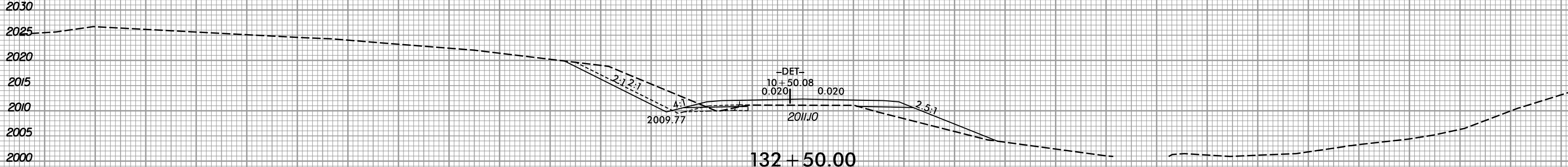
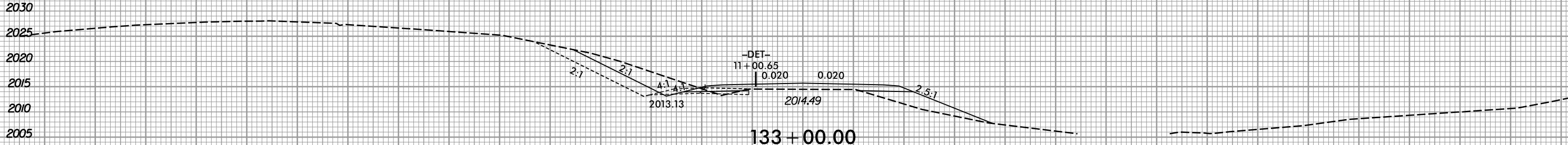
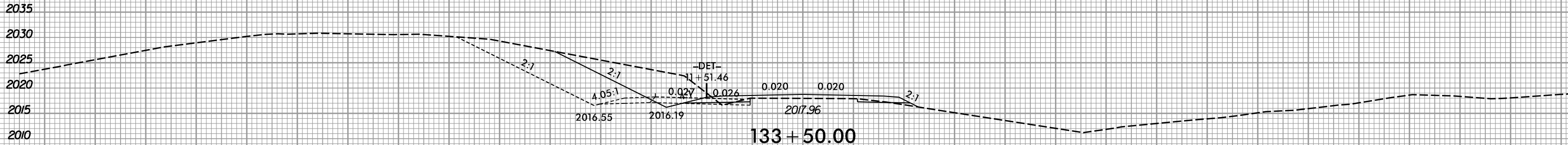
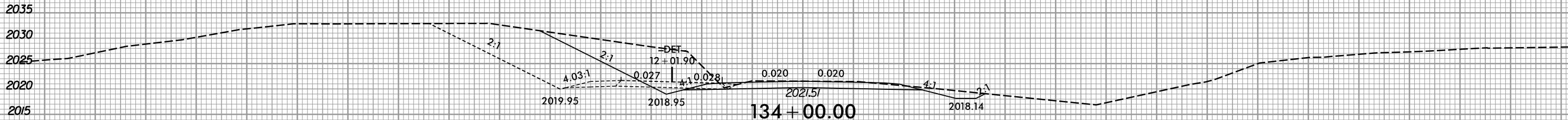

150 140 130 120 110 100 90 80 70 60 50 40 30 20 10 0 10 20 30 40 50 60 70 80 90 100 110 120 130 140 150

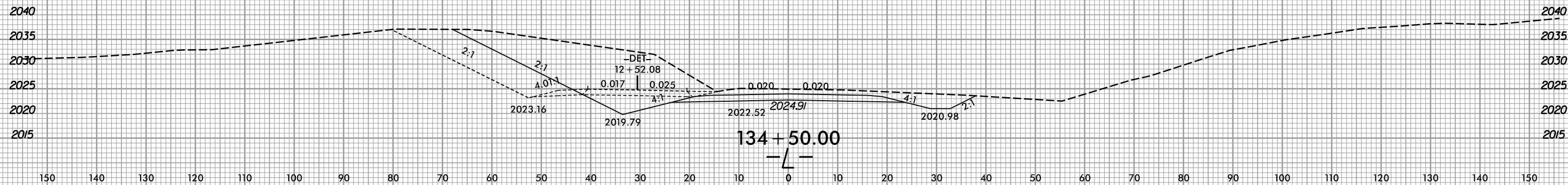
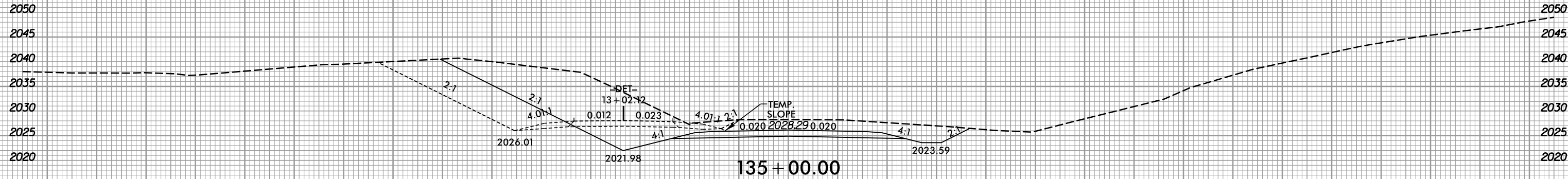
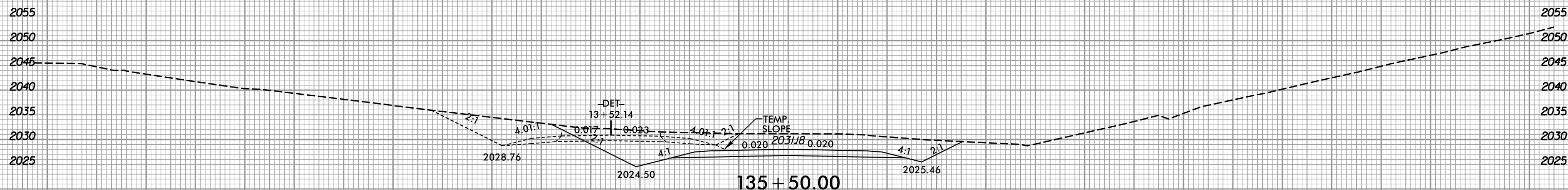
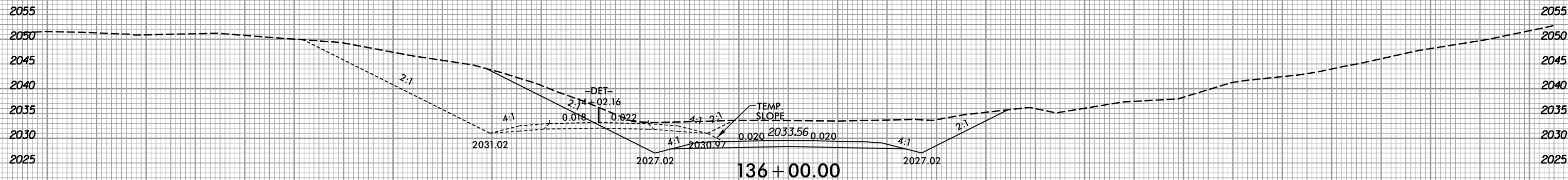
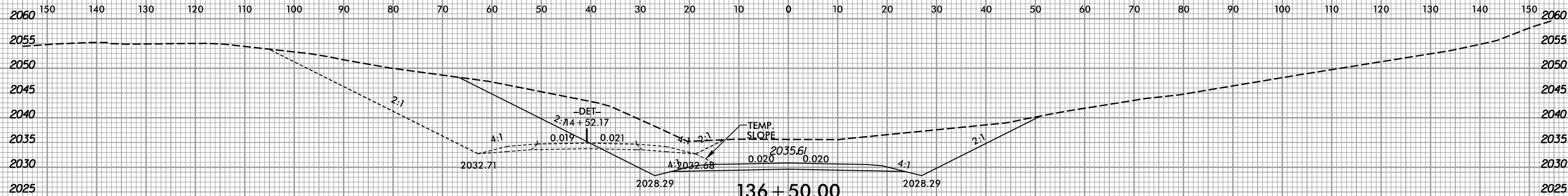



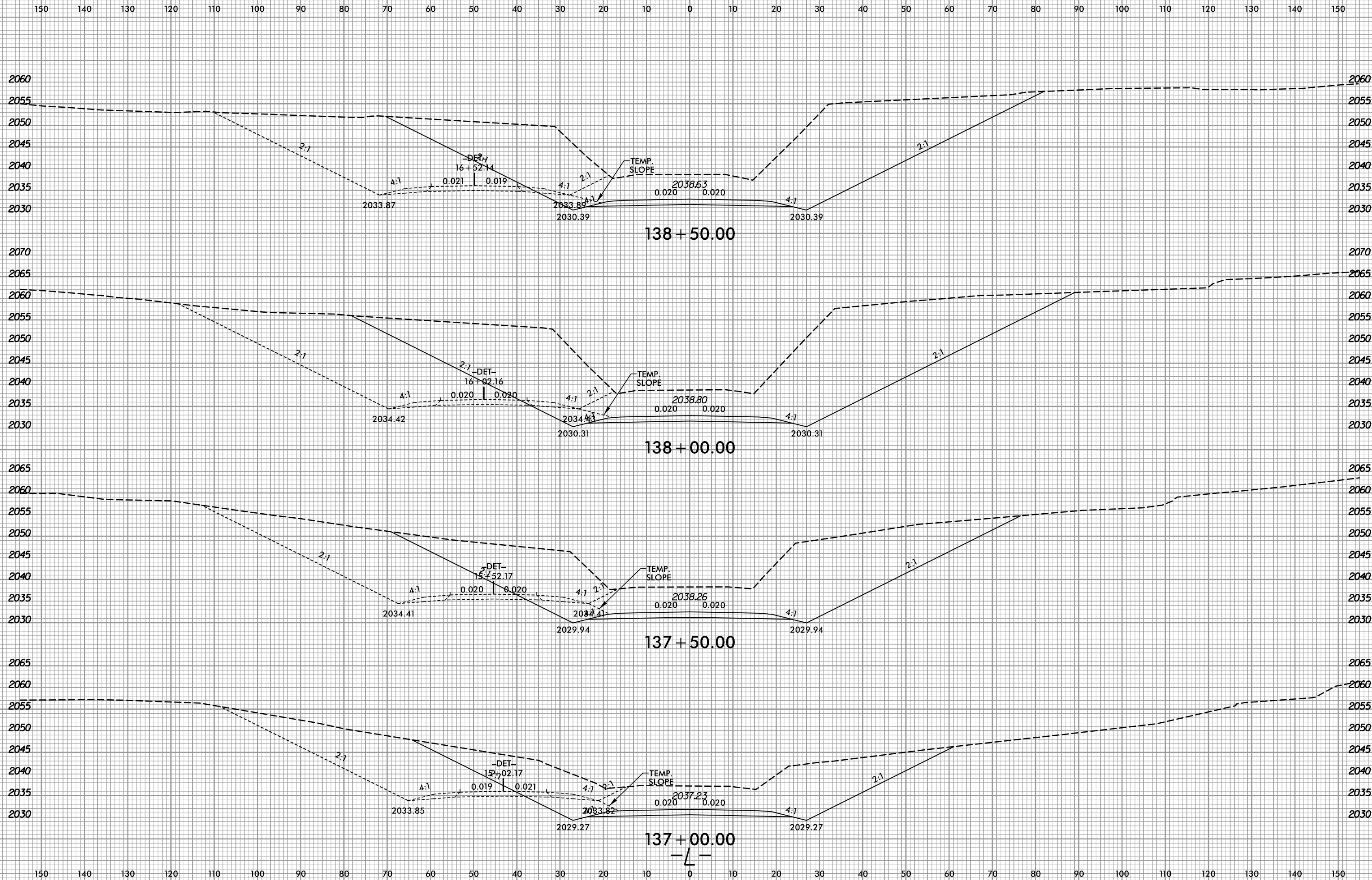



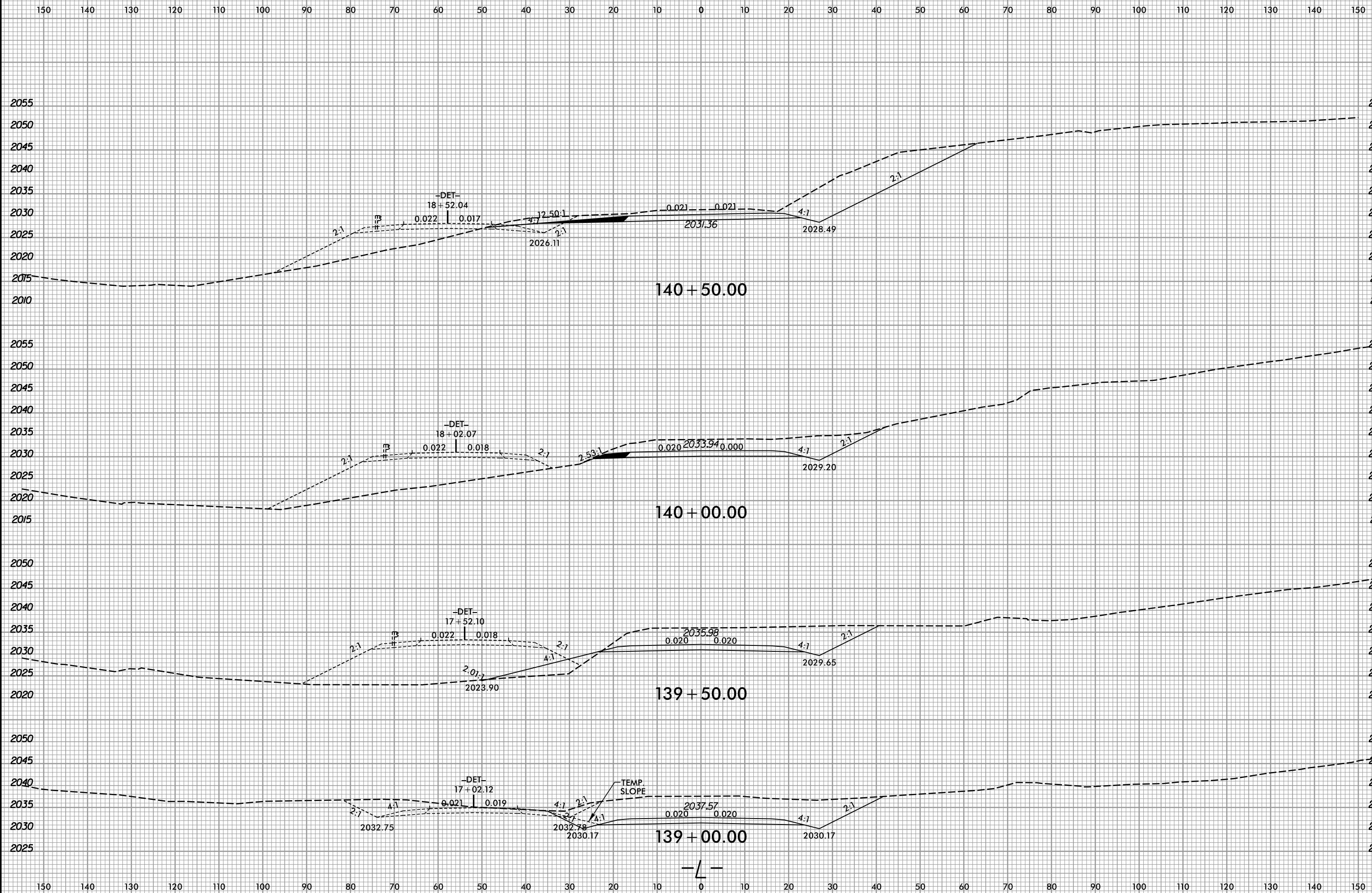

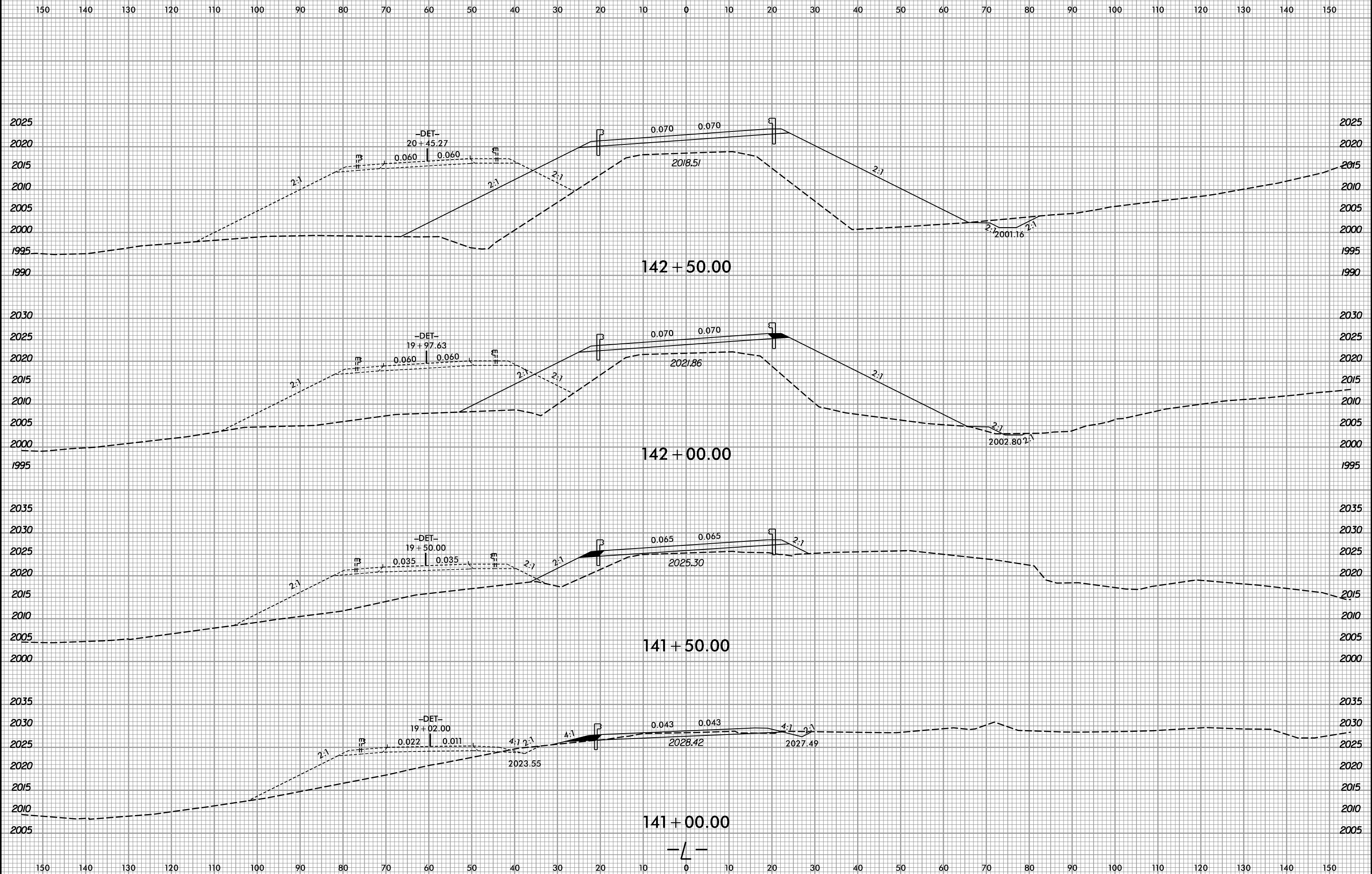

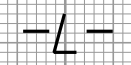
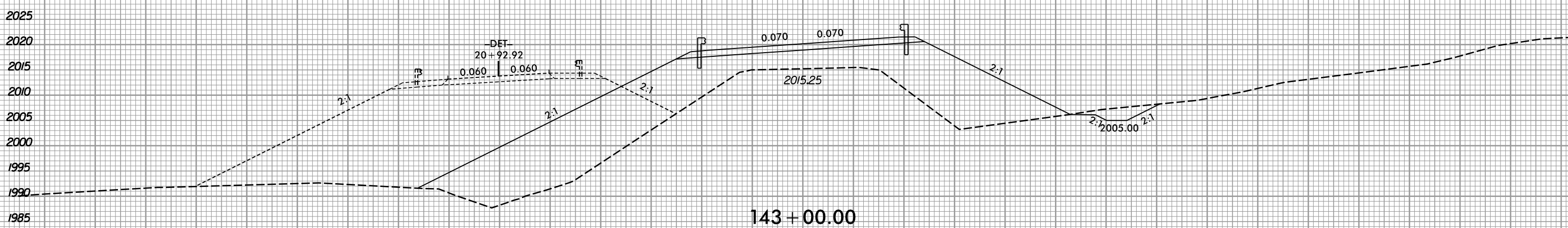
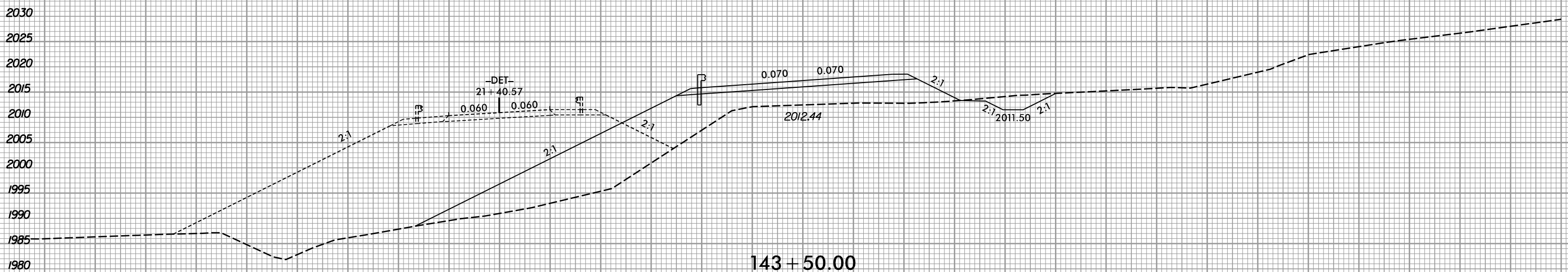
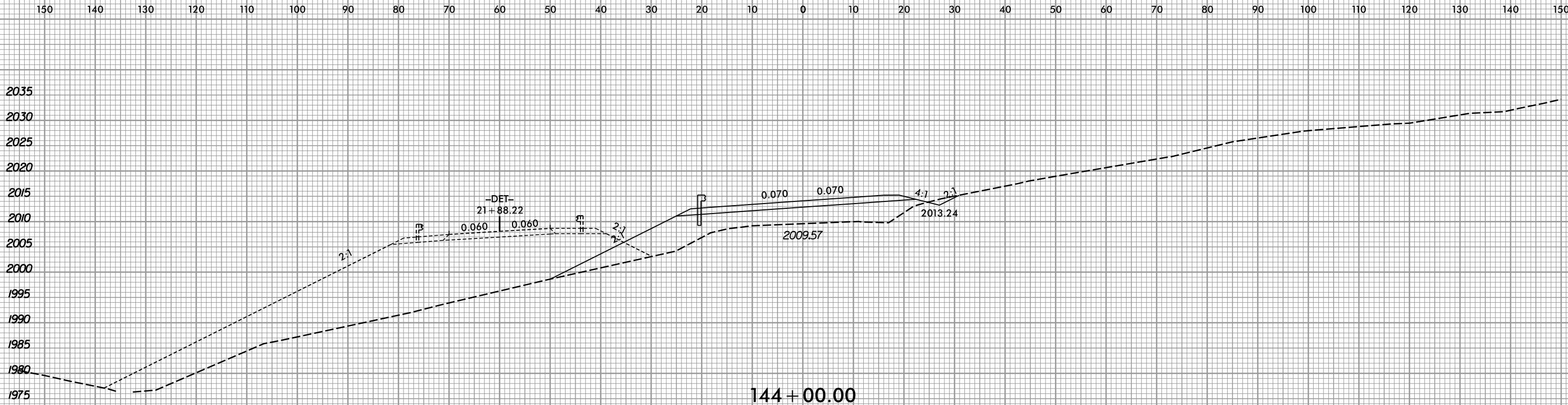



150 140 130 120 110 100 90 80 70 60 50 40 30 20 10 0 10 20 30 40 50 60 70 80 90 100 110 120 130 140 150

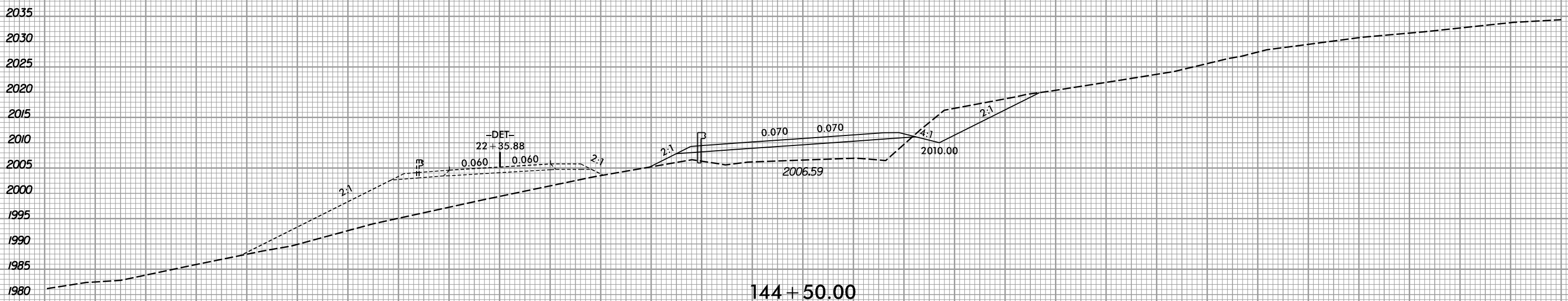
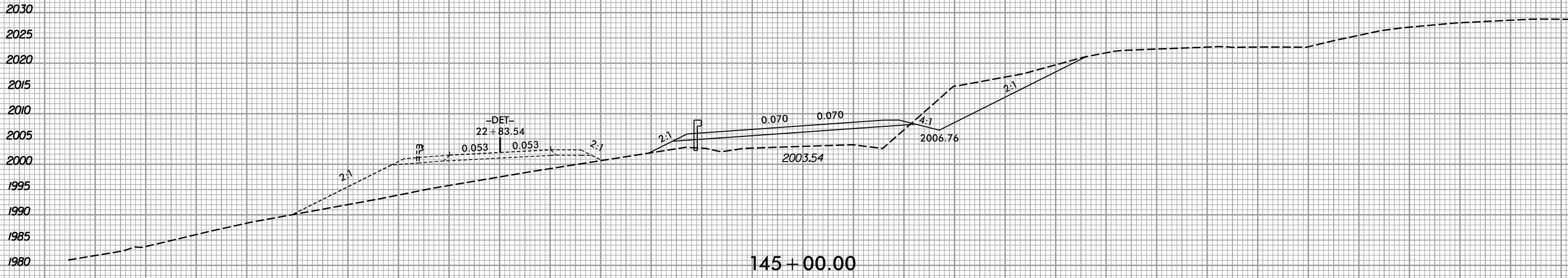

150 140 130 120 110 100 90 80 70 60 50 40 30 20 10 0 10 20 30 40 50 60 70 80 90 100 110 120 130 140 150

6/23/16



PROJ. REFERENCE NO.	SHEET NO.
R-5742	X-156

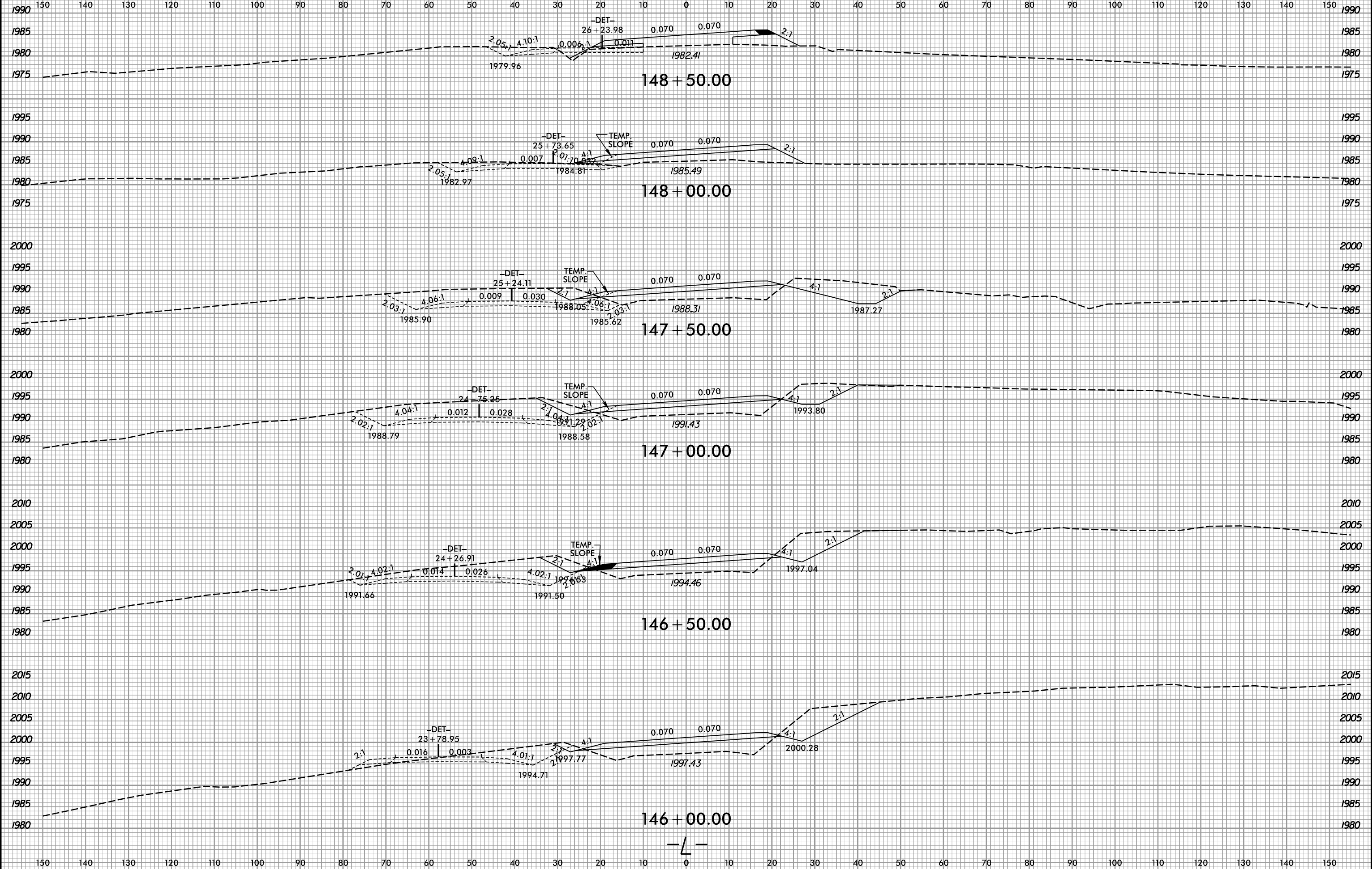

I2/14/2018  
R:\Roadway\Xsc\146-5742\_Rdy\_DET\_xpl.dgn  
gprlce

6/23/16



PROJ. REFERENCE NO.  
R-5742

SHEET NO.  
X-157

150 140 130 120 110 100 90 80 70 60 50 40 30 20 10 0 10 20 30 40 50 60 70 80 90 100 110 120 130 140 150

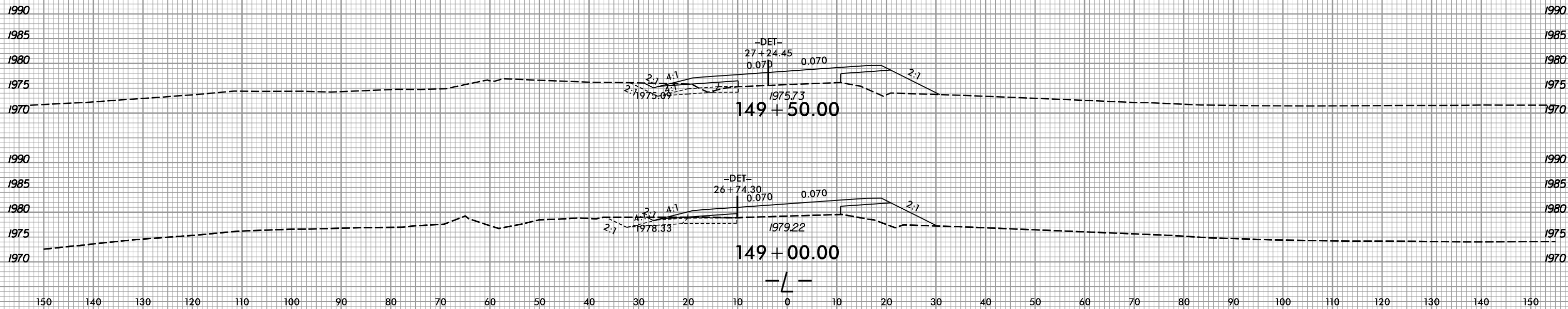

I2/14/2018  
R:\Roadway\Xsc\R-5742\_Rdy\_DET\_xpl.dgn  
gpr/ice

75 70 65 60 55 50 45 40 35 30 25 20 15 10 5 0 5 10 15 20 25 30 35 40 45 50 55 60 65 70 75

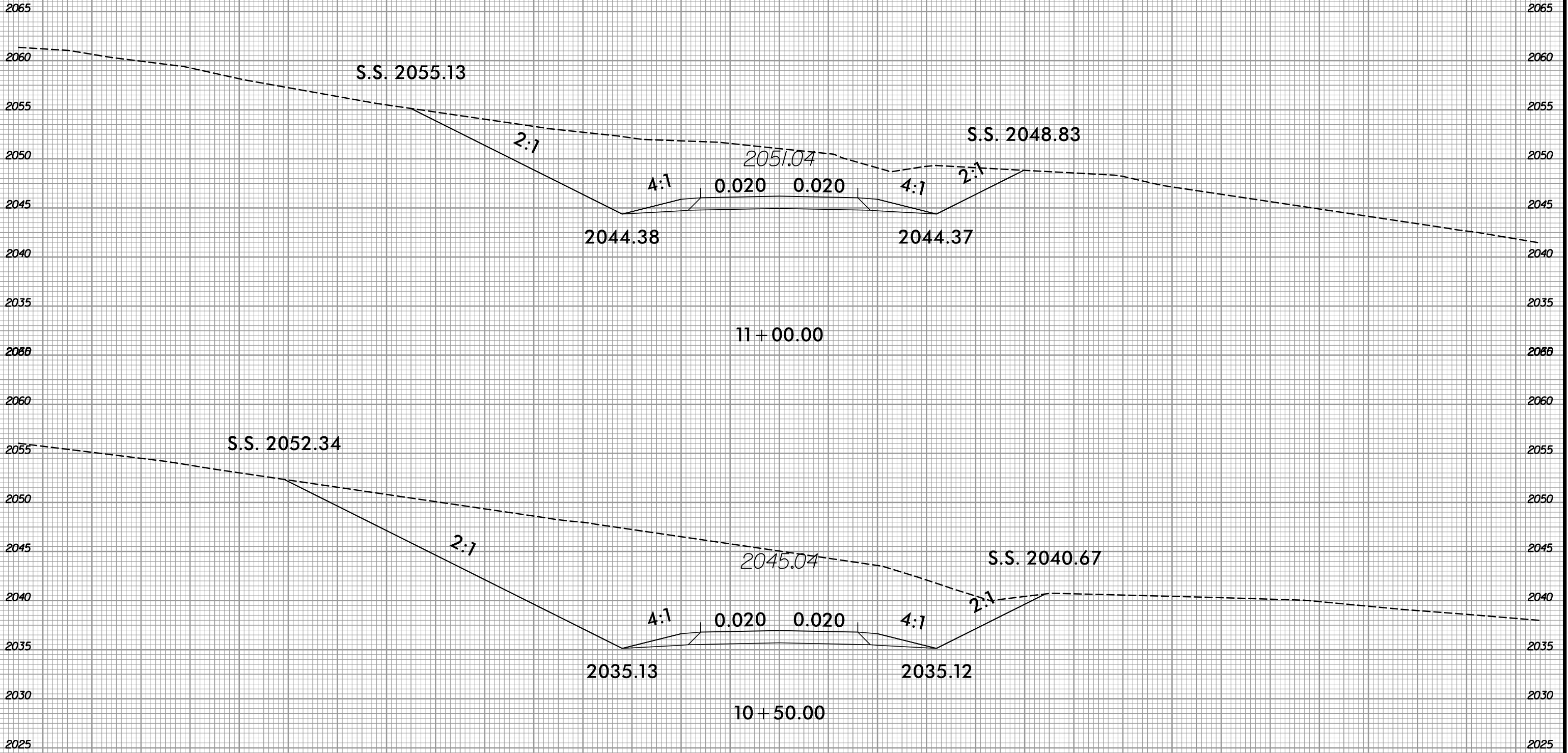

-DR11-

