

**This electronic collection of documents is provided
for the convenience of the user
and is Not a Certified Document –**

**The documents contained herein were originally issued
and sealed by the individuals whose names and license
numbers appear on each page, on the dates appearing
with their signature on that page.**

**This file or an individual page
shall not be considered a certified document.**

8/17/99

R-5742

**STATE OF NORTH CAROLINA
DEPARTMENT OF TRANSPORTATION**

**PAVEMENT MARKING PLAN
CLAY COUNTY**

LOCATION: NC 175 FROM GEORGIA STATE LINE TO US 64

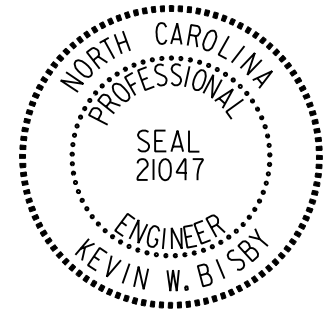
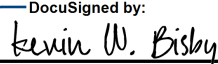
PROJECT REFERENCE NO. <i>R-5742</i>	SHEET NO. <i>PMP-1</i>
	
DocuSigned by:  11/9/2018	
DOCUMENT NOT CONSIDERED FINAL UNLESS ALL SIGNATURES COMPLETED	

ROADWAY STANDARD DRAWING

THE FOLLOWING ROADWAY STANDARDS AS APPEAR IN "ROADWAY STANDARD DRAWINGS" - PROJECT SERVICES UNIT - N.C. DEPARTMENT OF TRANSPORTATION - RALEIGH, N.C., DATED JANUARY 2018 ARE APPLICABLE TO THIS PROJECT AND BY REFERENCE HEREBY ARE CONSIDERED A PART OF THESE PLANS:

STD. NO.	TITLE
1205.01	PAVEMENT MARKINGS - LINE TYPES AND OFFSETS
1205.02	PAVEMENT MARKINGS - TWO-LANE AND MULTI-LANE ROADWAYS
1205.04	PAVEMENT MARKINGS - INTERSECTIONS
1205.05	PAVEMENT MARKINGS - TURN LANES
1205.08	PAVEMENT MARKINGS - SYMBOLS AND WORD MESSAGES
1205.09	PAVEMENT MARKINGS - PAINTED ISLANDS
1250.01	RAISED PAVEMENT MARKERS - INSTALLATION SPACING
1251.01	RAISED PAVEMENT MARKERS - PERMANENT AND TEMPORARY
1253.01	RAISED PAVEMENT MARKERS - SNOWPLOWABLE
1261.01	GUARDRAIL AND BARRIER DELINEATORS- INSTALLATION SPACING
1261.02	GUARDRAIL AND BARRIER DELINEATORS - TYPES AND MOUNTING
1262.01	GUARDRAIL END DELINEATION

INDEX

SHEET NO.	DESCRIPTION
PMP-1	PAVEMENT MARKING PLAN TITLE SHEET
PMP-1A	RUMBLE STRIP DETAIL
PMP-2 THRU PMP-7	PAVEMENT MARKING DETAILS

GENERAL NOTES

THE FOLLOWING GENERAL NOTES APPLY AT ALL TIMES FOR THE DURATION OF THE CONSTRUCTION PROJECT, EXCEPT WHEN OTHERWISE NOTED IN THE PLAN, OR DIRECTED BY THE ENGINEER.

- A) INSTALL PAVEMENT MARKINGS AND PAVEMENT MARKERS ON THE FINAL SURFACE AS FOLLOWS:

ROAD NAME	MARKING	MARKER
-L- LINE, -Y- LINES	THERMOPLASTIC	SNOWPLOWABLE

- B) TIE PROPOSED PAVEMENT MARKING LINES TO EXISTING PAVEMENT MARKING LINES.
C) REMOVE/REPLACE ANY CONFLICTING/DAMAGED PAVEMENT MARKINGS AND MARKERS.

PAVEMENT MARKING SCHEDULE

THERMOPLASTIC

- (TA) - 4" WHITE EDGE LINE, 90 MILS
- (TE) - 4" WHITE SOLID LANE LINE, 120 MILS
- (TD) - 4" 3FT.-9FT./SP WHITE MINISKIP, 120 MILS
- (TI) - 4" YELLOW DOUBLE CENTER LINE, 120 MILS
- (TN) - 8" WHITE GORELINE, 90 MILS
- (TU) - 12" WHITE DIAGONAL, 90 MILS
- (TV) - 12" YELLOW DIAGONAL, 90 MILS
- (T2) - 24" WHITE STOPBAR, 120 MILS
- (T4) - 4" WHITE RUMBLE STRIP, 240 MILS
- (T8) - 4" 2FT.-6FT./SP WHITE MINISKIP, 120 MILS
- (UA) - LEFT TURN ARROW, 90 MILS
- (UB) - RIGHT TURN ARROW, 90 MILS

MARKERS

- (ME) - YELLOW/YELLOW, SNOWPLOWABLE
- (MF) - CRYSTAL/RED, SNOWPLOWABLE

TIP PROJECT:

11/9/2018
R-5742_PMP-1.dgn
KWB

PAVEMENT MARKING PLAN
PLANS PREPARED BY :
C. BYRON HOLDEN, P.E. PROJECT ENGINEER
M. A. COLE PROJECT DESIGNER

PLANS PREPARED BY :
RK&K
RUMMEL, KLEPPER & KAHL, LLP
900 RIDGEFIELD DRIVE SUITE 350
RALEIGH, NORTH CAROLINA 27609-3960
NC LICENSE NO. F-0112 • (919) 878-9560

STATE OF NORTH CAROLINA DEPT. OF TRANSPORTATION DIVISION OF HIGHWAYS RALEIGH, N.C.	11-13 ENGLISH STANDARD DRAWING FOR TWO-LANE, TWO-WAY THERMOPLASTIC RUMBLE STRIPS	STATE OF NORTH CAROLINA DEPT. OF TRANSPORTATION DIVISION OF HIGHWAYS RALEIGH, N.C.
GENERAL NOTES: 1. ALL RUMBLE STRIPS SHALL BE CENTERED IN THE LANE AND SHALL BE 2 FEET LESS THAN THE WIDTH OF THE TRAVEL LANE. 2. RUMBLE STRIPS SHALL BE PLACED USING 4" X 240 MIL WHITE THERMOPLASTIC PAVEMENT MARKING MATERIAL. 3. PLACEMENT OF STOP-AHEAD (W3-1) OR SIGNAL-AHEAD (W3-3) SIGNS SHALL COMPLY WITH THE 2009 MUTCD SECTION 5C.04.		
SHEET 1 OF 1		SHEET 1 OF 1

STATE OF NORTH CAROLINA DEPT. OF TRANSPORTATION DIVISION OF HIGHWAYS RALEIGH, N.C.	11-13 ENGLISH STANDARD DRAWING FOR MULTI-LANE THERMOPLASTIC RUMBLE STRIPS	STATE OF NORTH CAROLINA DEPT. OF TRANSPORTATION DIVISION OF HIGHWAYS RALEIGH, N.C.
GENERAL NOTES: - ALL RUMBLE STRIPS SHALL BE CENTERED IN THE LANE AND SHALL BE 2 FEET LESS THAN THE WIDTH OF THE TRAVEL LANES. - RUMBLE STRIPS SHALL BE PLACED USING 4" X 240 MIL WHITE THERMOPLASTIC PAVEMENT MARKING MATERIAL. - PLACEMENT OF SIGNAL-AHEAD (W3-3) SIGNS SHALL COMPLY WITH THE 2009 MUTCD SECTION 5C.04. - SIGNS SHALL BE DUAL MOUNTED WITH TYPE 'B' WARNING FLAGS.		
SHEET 1 OF 1		SHEET 1 OF 1

APPROVED: _____
 DATE: _____

SEAL

**DOCUMENT NOT CONSIDERED FINAL
 UNLESS ALL SIGNATURES COMPLETED**

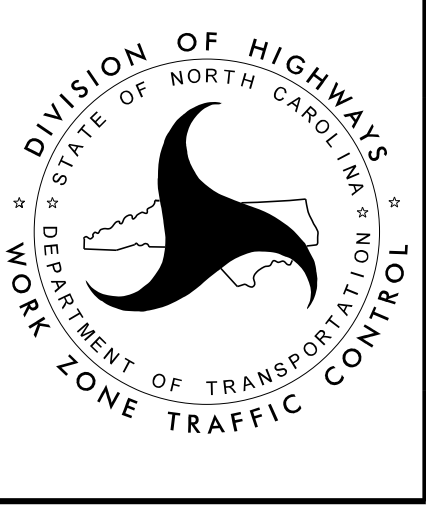

RUMBLE STRIP DETAIL

11/29/2018
 R5742_PMP_pmp01A.dgn
 kbisby

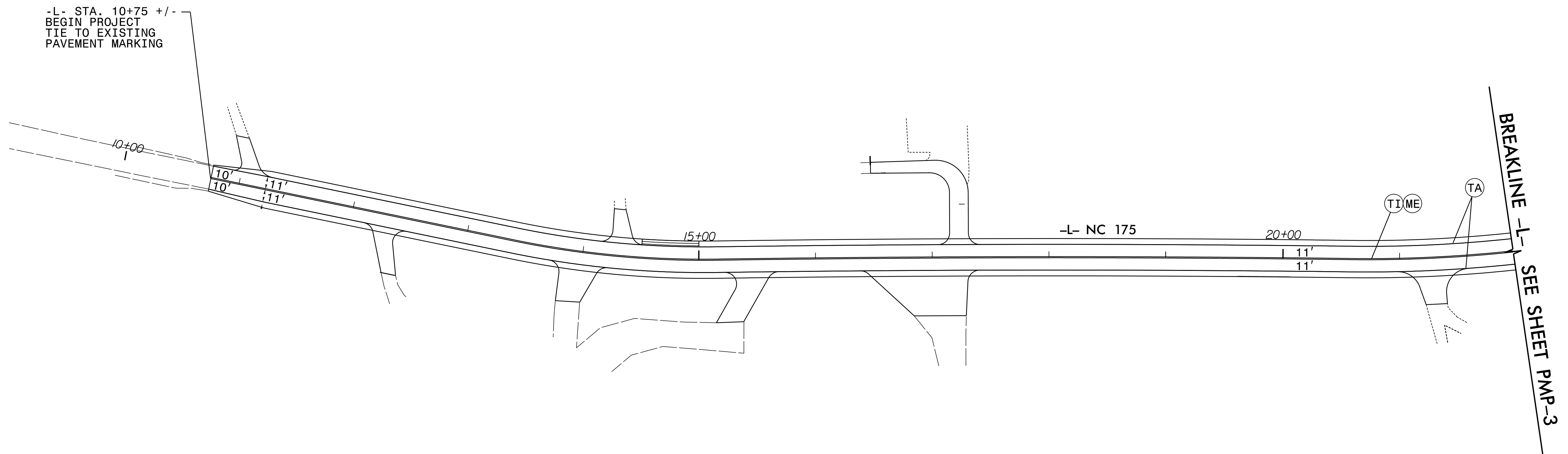

11/9/2018
R5742_PMP_pmp02.dgn
KBISBY

PLANS PREPARED BY :



RUMMEL, KLEPPER & KAHL, LLP
900 RIDGEFIELD DRIVE SUITE 350
RALEIGH, NORTH CAROLINA 27609-3960
NC LICENSE NO. F-0112 • (919) 878-9560

APPROVED: *Kevin W. Bisby*

DATE: 11/9/2018

SEAL

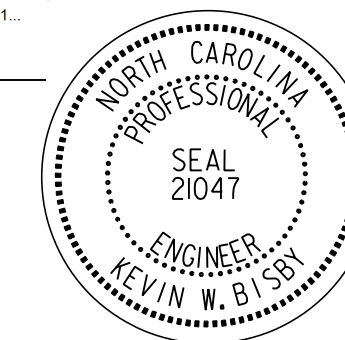

DOCUMENT NOT CONSIDERED FINAL
UNLESS ALL SIGNATURES COMPLETED

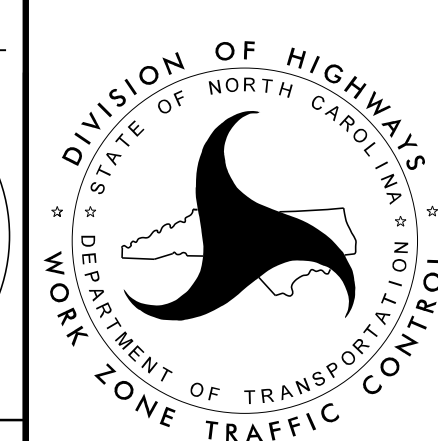

PAVEMENT MARKING
DETAIL

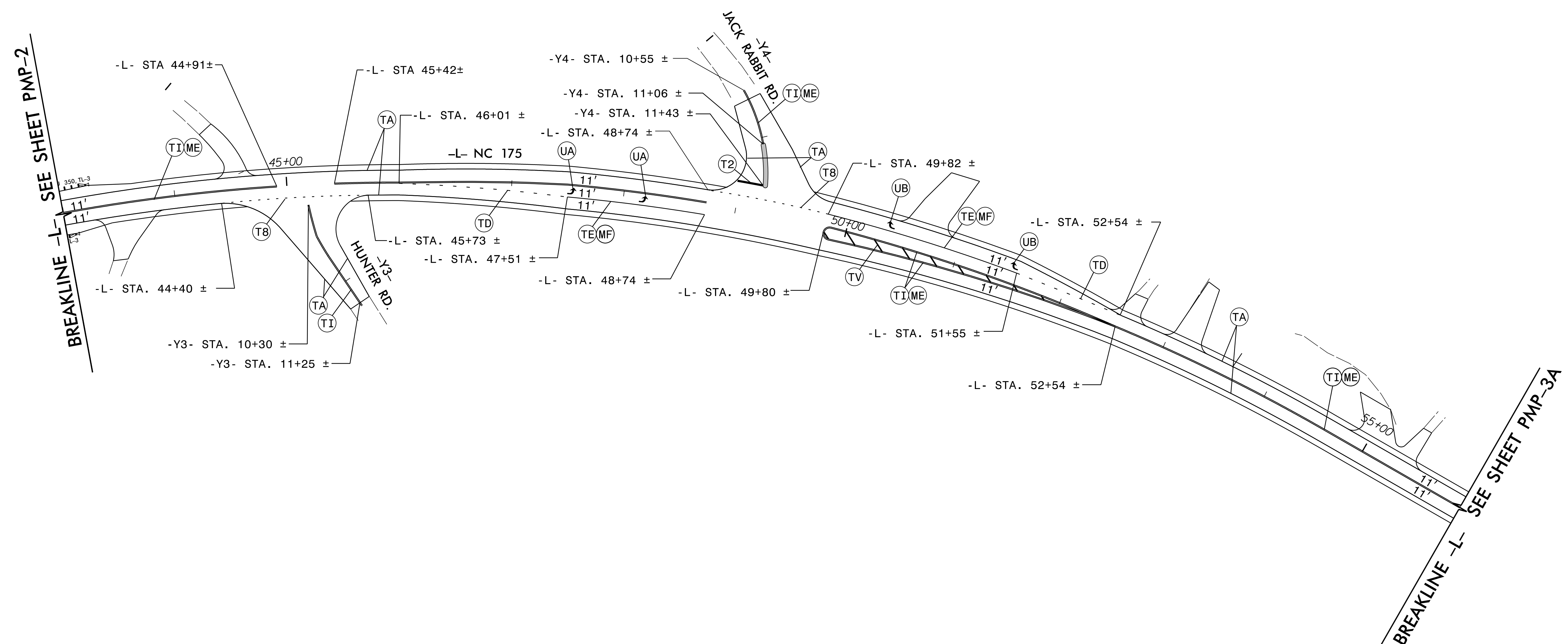

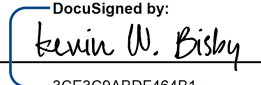
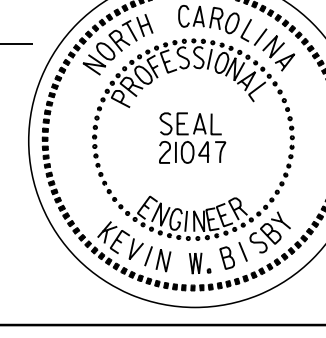
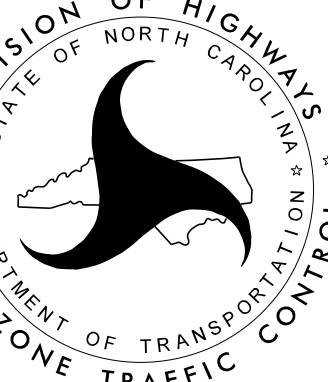
<p>PLANS PREPARED BY :</p> <p>RK&K</p> <p>RUMMEL, KLEPPER & KAHL, LLP 900 RIDGEFIELD DRIVE SUITE 350 RALEIGH, NORTH CAROLINA 27609-3960 NC LICENSE NO. F-0112 • (919) 878-9560</p>	<p>APPROVED: </p> <p>DATE: 11/9/2018</p> <p>SEAL</p> <p></p> <p>DOCUMENT NOT CONSIDERED FINAL UNLESS ALL SIGNATURES COMPLETED</p>	<p></p> <p>DIVISION OF HIGHWAYS STATE OF NORTH CAROLINA DEPARTMENT OF TRANSPORTATION WORK ZONE TRAFFIC CONTROL</p>	<p>PAVEMENT MARKING DETAIL</p>
---	--	--	---

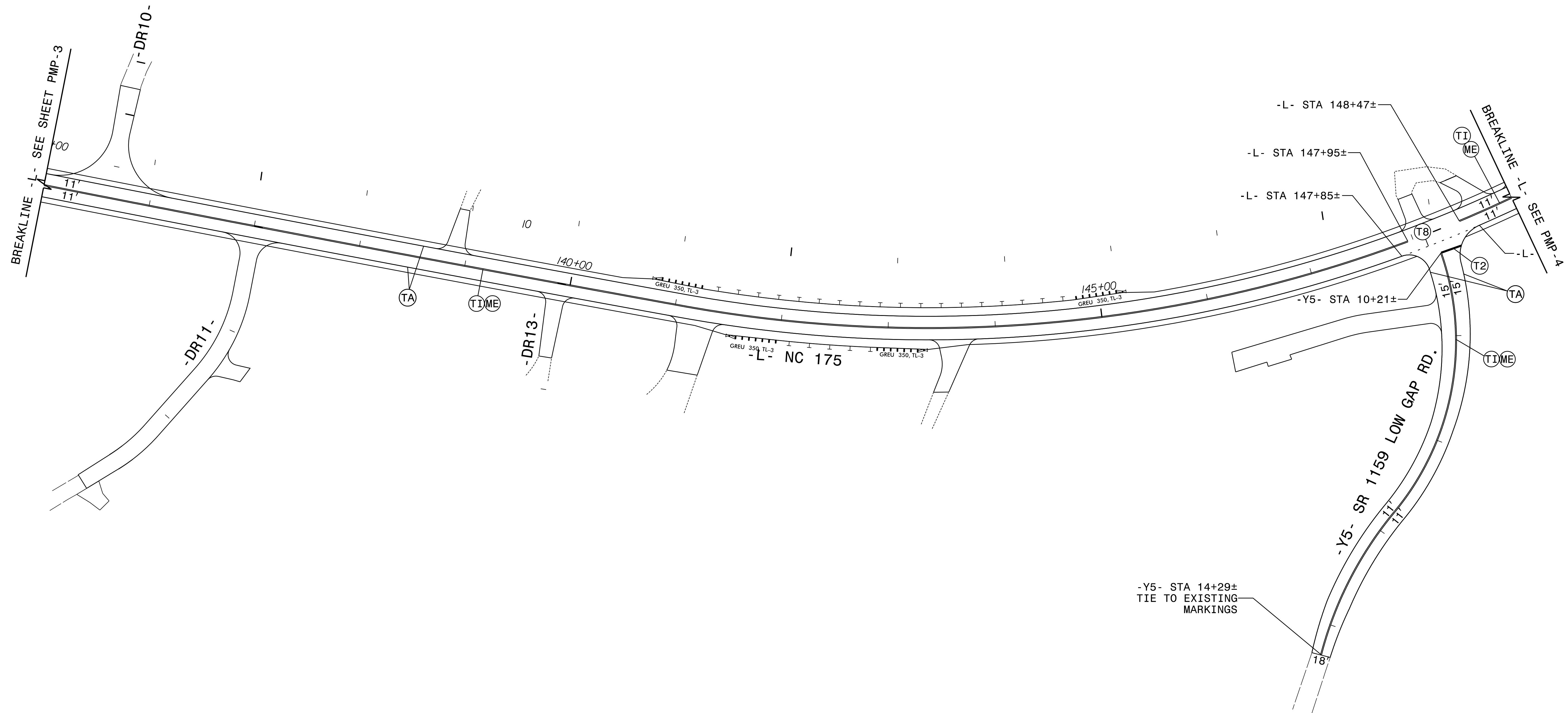

11/9/2018
R5742_PMP_pmp03A.dgn
KBSBY

PLANS PREPARED BY :



RUMMEL, KLEPPER & KAHL, LLP
900 RIDGEFIELD DRIVE SUITE 350
RALEIGH, NORTH CAROLINA 27609-3960
NC LICENSE NO. F-0112 • (919) 878-9560

APPROVED: *Kevin W. Bixby*
3CE3C8ABDF484B1

DATE: 11/9/2018

SEAL

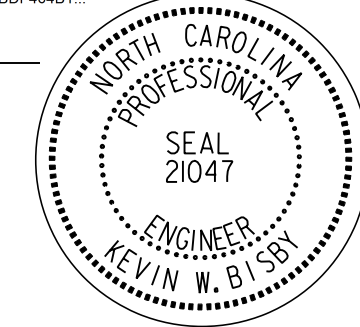

DOCUMENT NOT CONSIDERED FINAL
UNLESS ALL SIGNATURES COMPLETED

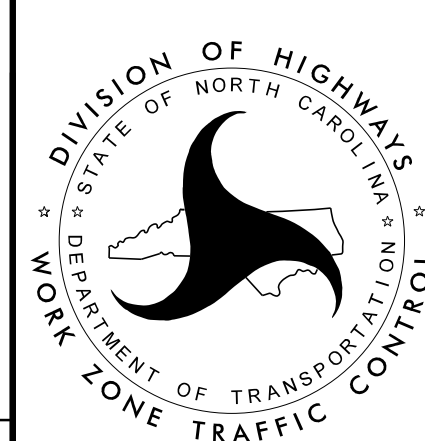

PAVEMENT MARKING
DETAIL



BREAKLINE -L- SEE SHEET PMP-3A

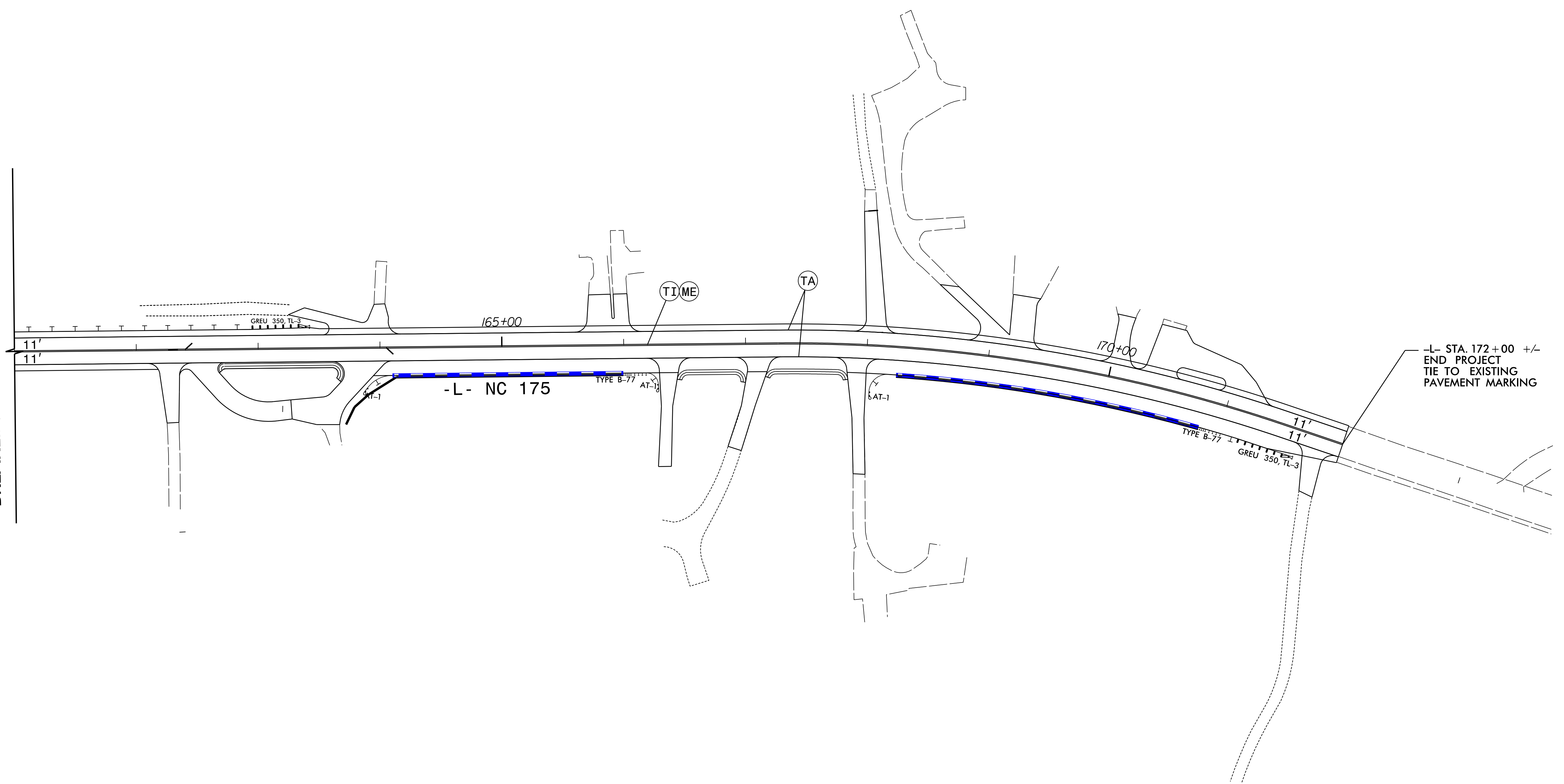

11/9/2018
 PG7/21
 R-5742_PMP_pmp04.dgn
 RLSBby

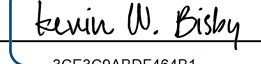
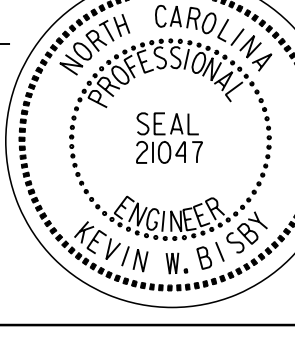
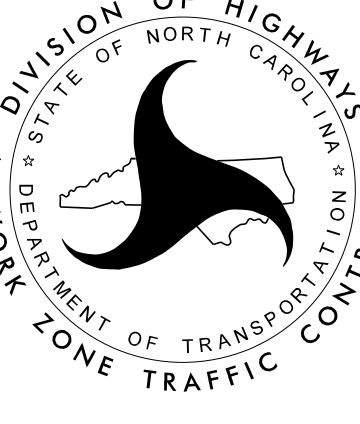
<p>PLANS PREPARED BY :</p> <p>RK&K</p> <p>RUMMEL, KLEPPER & KAHL, LLP 900 RIDGEFIELD DRIVE SUITE 350 RALEIGH, NORTH CAROLINA 27609-3960 NC LICENSE NO. F-0112 • (919) 878-9560</p>	<p>APPROVED: </p> <p>DATE: 11/9/2018</p> <p>SEAL</p> <p></p> <p>DOCUMENT NOT CONSIDERED FINAL UNLESS ALL SIGNATURES COMPLETED</p>	<p></p> <p>DIVISION OF HIGHWAYS NORTH CAROLINA DEPARTMENT OF TRANSPORTATION WORK ZONE TRAFFIC CONTROL</p>	<p>PAVEMENT MARKING DETAIL</p>
---	---	---	--

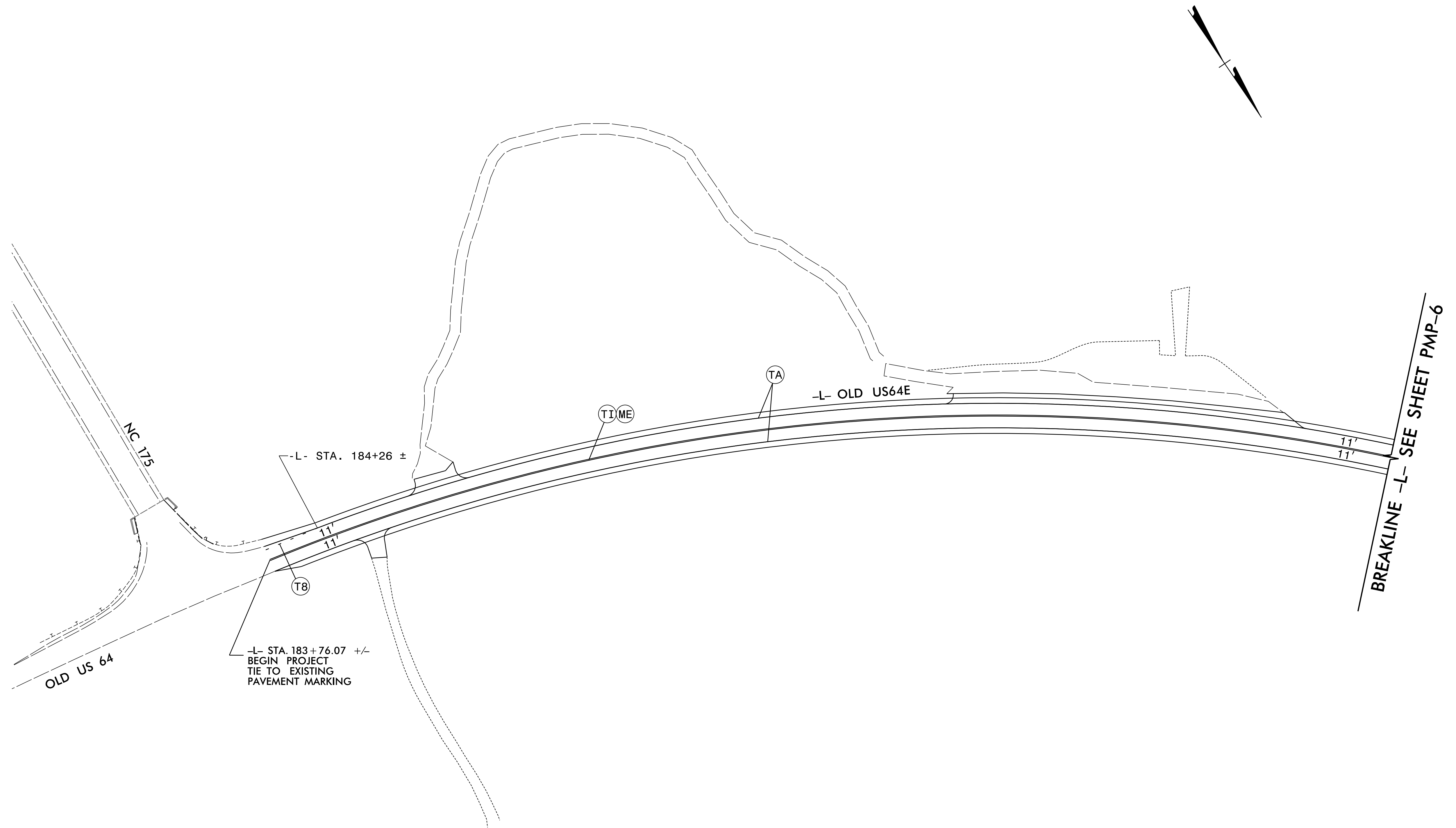

11/9/2018
R5742_PMP_pmp05.dgn
KBISBY

PLANS PREPARED BY :

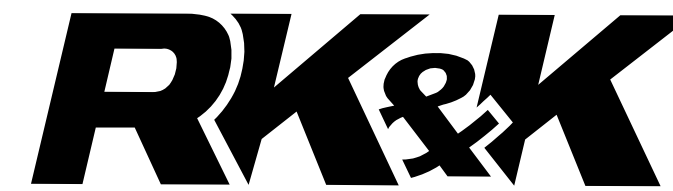

RUMMEL, KLEPPER & KAHL, LLP
900 RIDGEFIELD DRIVE SUITE 350
RALEIGH, NORTH CAROLINA 27609-3960
NC LICENSE NO. F-0112 • (919) 878-9560

APPROVED: *Kevin W. Bishy*
3CE3C8ABDF484B1

DATE: 11/9/2018

SEAL

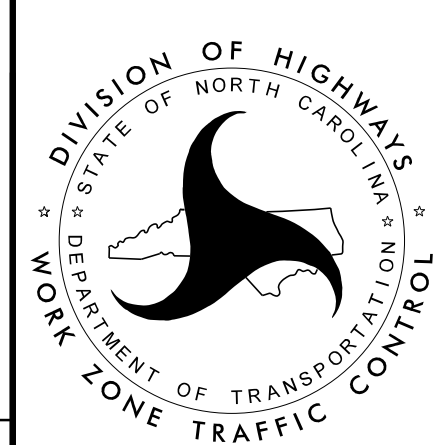
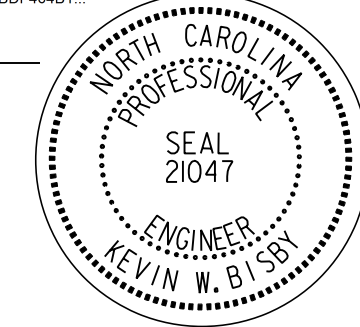

PAVEMENT MARKING
DETAIL

DOCUMENT NOT CONSIDERED FINAL
UNLESS ALL SIGNATURES COMPLETED

PROJ. REFERENCE NO.	SHEET NO.
R-5742	PMP-6

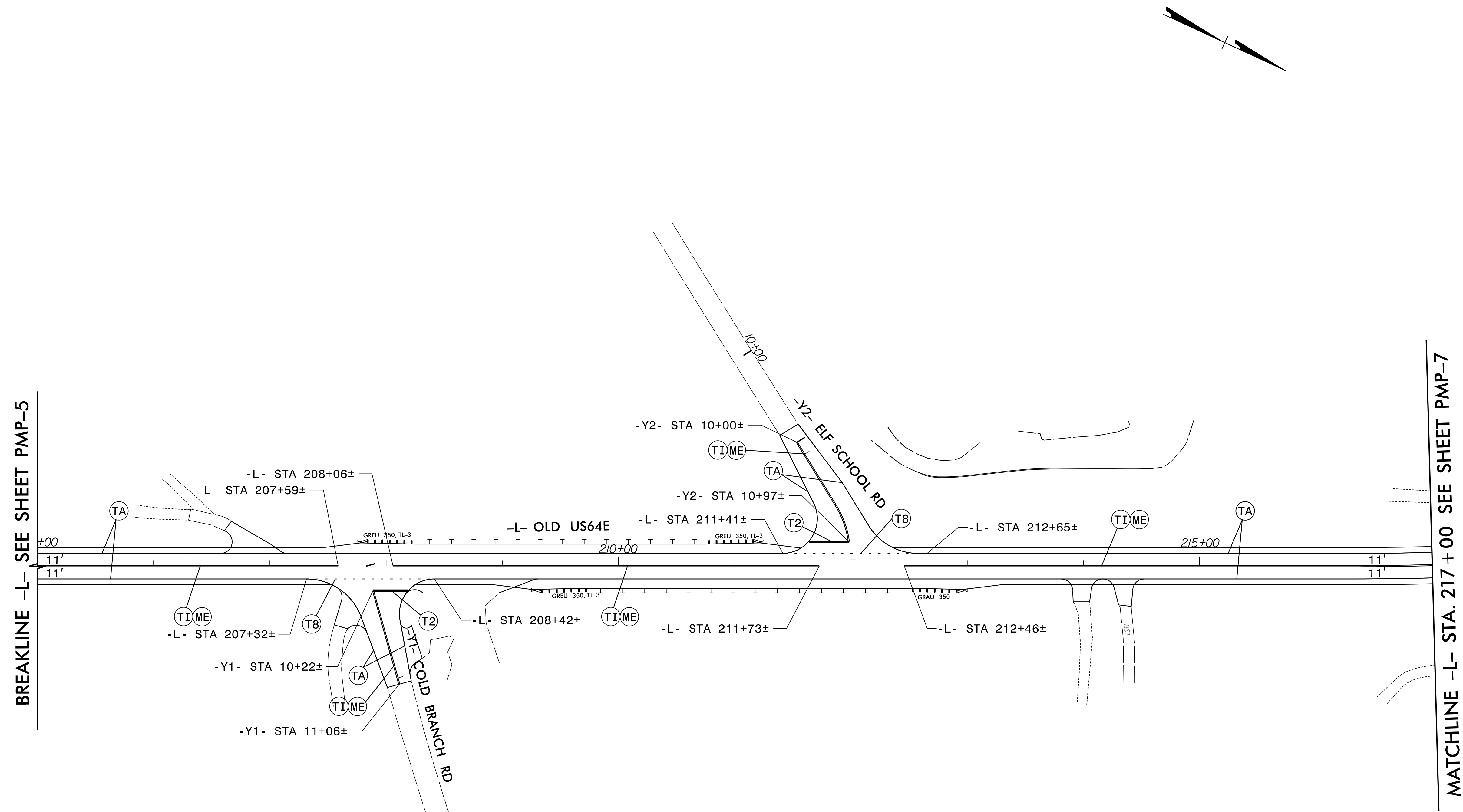

BREAKLINE -L- SEE SHEET PMP-5

MATCHLINE -L- STA. 217 + 00 SEE SHEET PMP-7

11/9/2018
R5742_PMP_pmp06.dgn
KBISBY

<p>PLANS PREPARED BY :</p> <p>RK&K</p> <p>RUMMEL, KLEPPER & KAHL, LLP 900 RIDGEFIELD DRIVE SUITE 350 RALEIGH, NORTH CAROLINA 27609-3960 NC LICENSE NO. F-0112 • (919) 878-9560</p>	<p>APPROVED: <i>Kevin W. Bixby</i> 3CE3C8ABDF484B1</p> <p>DATE: 11/9/2018</p> <p>SEAL</p>		<p>PAVEMENT MARKING DETAIL</p>
<p>DOCUMENT NOT CONSIDERED FINAL UNLESS ALL SIGNATURES COMPLETED</p>			

MATCHLINE -L- STA. 217 + 00 SEE SHEET PMP-6

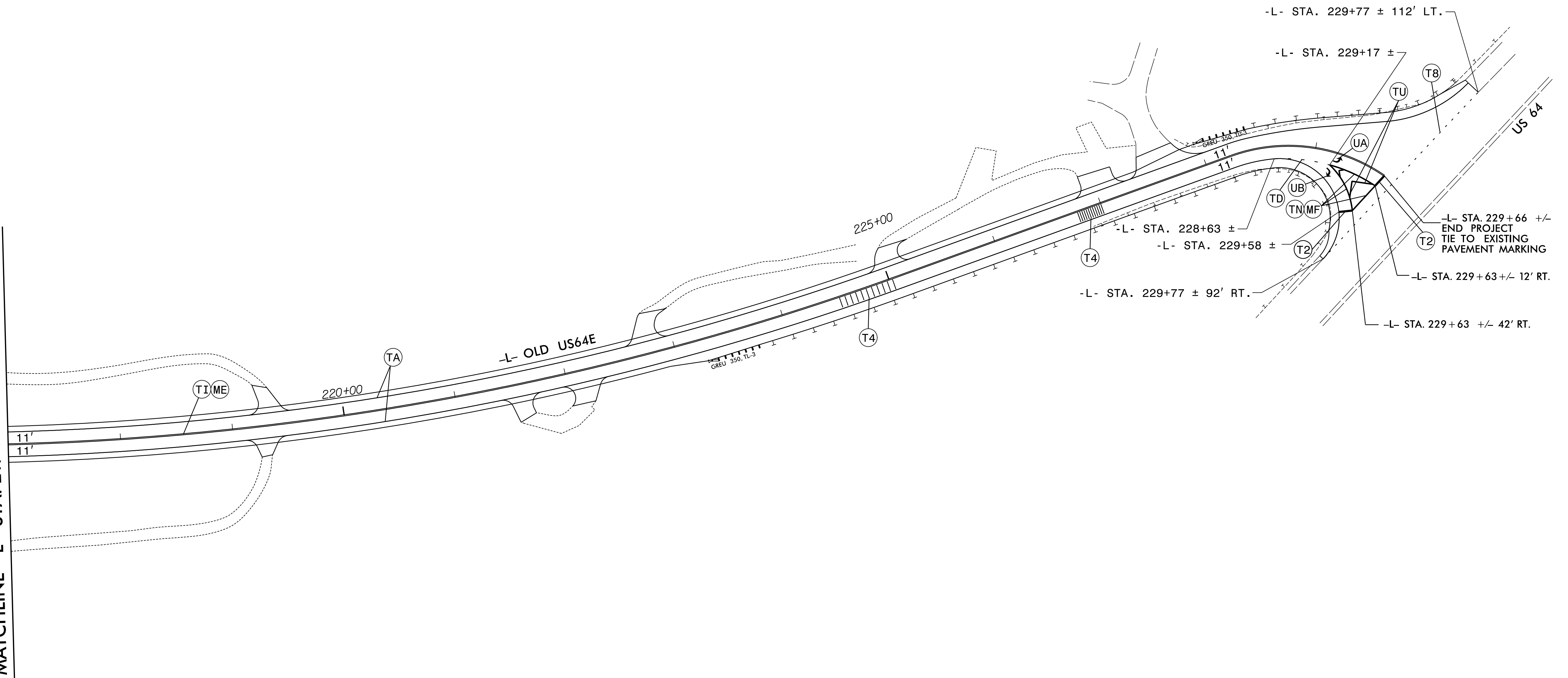

11/9/2018
R5742_PMP_pmp07.dgn
KBISBY

PLANS PREPARED BY :



RUMMEL, KLEPPER & KAHL, LLP
900 RIDGEFIELD DRIVE SUITE 350
RALEIGH, NORTH CAROLINA 27609-3960
NC LICENSE NO. F-0112 • (919) 878-9560

APPROVED: *Kevin W. Bixby*

DATE: 11/9/2018

SEAL

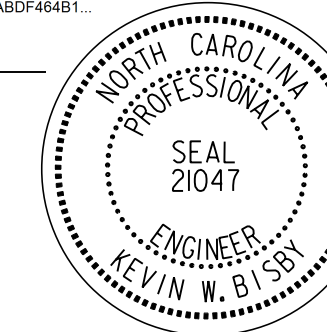

DOCUMENT NOT CONSIDERED FINAL
UNLESS ALL SIGNATURES COMPLETED

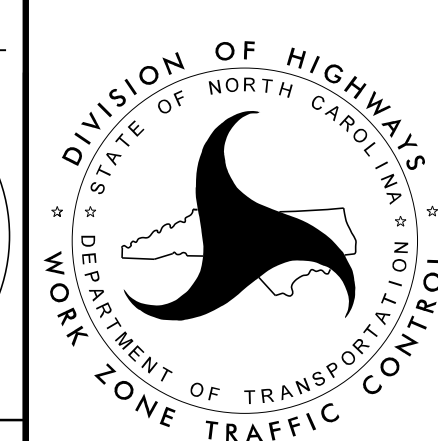

PAVEMENT MARKING
DETAIL