

PROJECT REFERENCE NO.	SHEET NO.
R-5742	EC-17/CONST.-15
RW SHEET NO.	
ROADWAY DESIGN ENGINEER	HYDRAULICS ENGINEER

CLEARING AND GRUBBING
EROSION CONTROL FOR
CONSTRUCTION SHEET 15

NOTE:
PLACE TEMPORARY ROCK SEDIMENT DAMS TYPE - B
AND TEMPORARY ROCK SILT CHECKS TYPE - A AT
DRAINAGE OUTLETS.

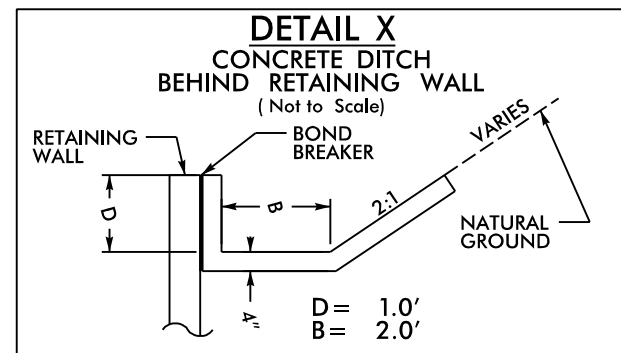

-L- STA. 164+00 TO STA. 165+90 RT
-L- STA. 168+30 TO STA. 170+80 RT

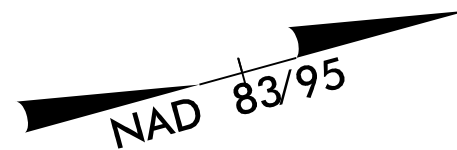

-L-		-DR16-
PI Sta 169+39.08	PI Sta 177+07.00	PI Sta 10+69.94
$\Delta = 19' 17'' 00.6''$ (RT)	$\Delta = 22' 12'' 59.2''$ (LT)	$\Delta = 54' 49'' 26.8''$ (LT)
D = 4' 35'' 01.2"	D = 6' 44'' 26.4"	D = 143' 14'' 22.0"
L = 420.70'	L = 329.59'	L = 38.27'
T = 212.36'	T = 166.89'	T = 20.74'
R = 1,250.00'	R = 850.00'	R = 40.00'
SE = 0.07		
V = 50 mph		

FOR -L- PROFILE SEE SHTS. 25 & 26
FOR -DR16- & -DR20- PROFILES SEE SHT. 29
FOR WALLS 4&5 PROFILES SEE SHT. W-3
NOTE: ALL DRIVEWAY WIDTHS ARE 16' UNLESS OTHERWISE NOTED.
ALL DRIVEWAY RADII ARE 10' UNLESS OTHERWISE NOTED.

PLANS PREPARED BY :

RUMMEL, KLEPPER & KAHL, LLP
900 RIDGEFIELD DRIVE SUITE 350
RALEIGH, NORTH CAROLINA 27609-3960
NC LICENSE NO. F-0112 • (919) 878-9560

8.17.99
R:\Hydraulics\CADD\PSH\Erosion_Control\NR-5742_EC_psh15.dgn