

MATCHLINE -L- STA. 217 + 00 SEE SHEET PMP-6

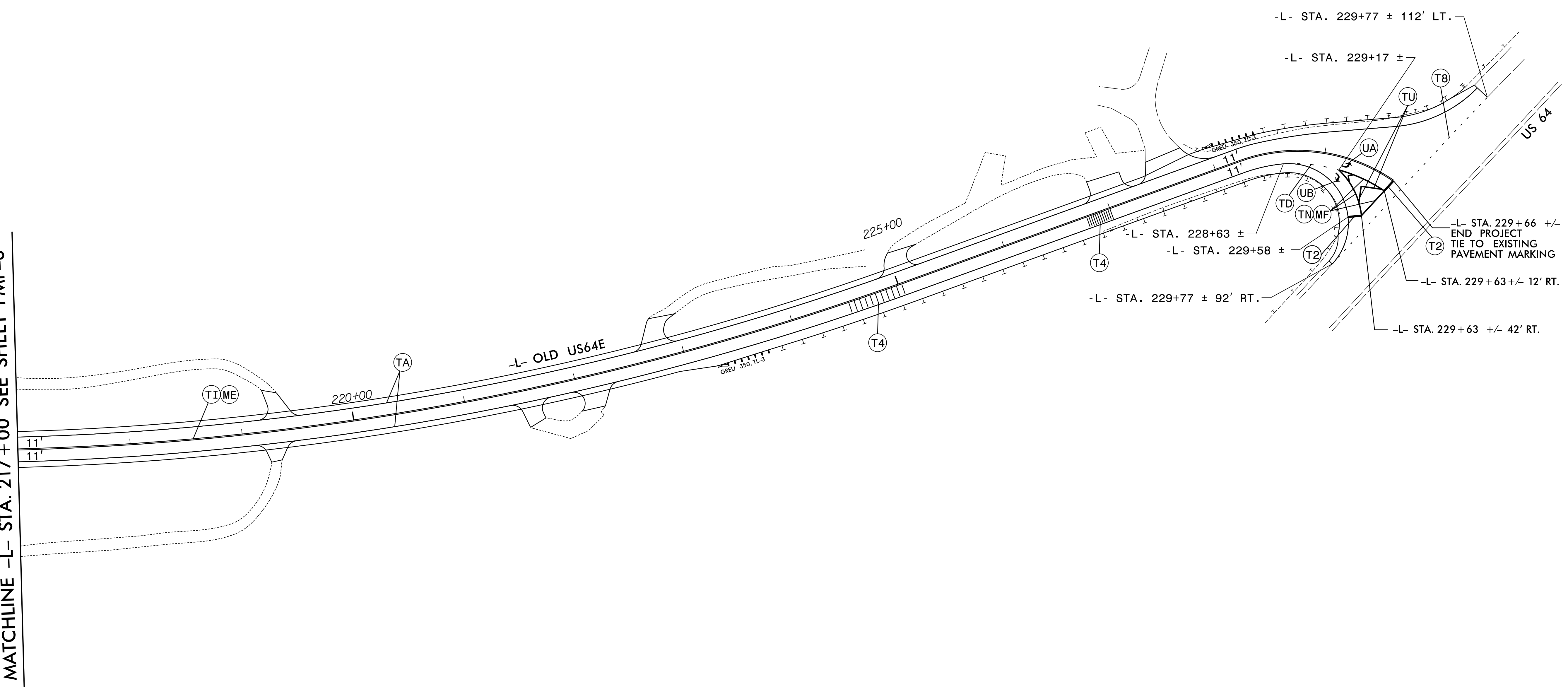

11/9/2018
R5742_PMP_pmp07.dgn
KBISBY

<p>PLANS PREPARED BY :</p> <p>RK&K</p> <p>RUMMEL, KLEPPER & KAHL, LLP 900 RIDGEFIELD DRIVE SUITE 350 RALEIGH, NORTH CAROLINA 27609-3960 NC LICENSE NO. F-0112 • (919) 878-9560</p>	<p>APPROVED: <i>Kevin W. Bixby</i> 3CE3C8ABDF484B1</p> <p>DATE: 11/9/2018</p> <p>SEAL</p>	<p>STATE OF NORTH CAROLINA DEPARTMENT OF TRANSPORTATION WORK ZONE TRAFFIC CONTROL</p>	<p>PAVEMENT MARKING DETAIL</p>
<p>DOCUMENT NOT CONSIDERED FINAL UNLESS ALL SIGNATURES COMPLETED</p>			