

STATE	PROJECT NO.	SHEET NO.	TOTAL SHEETS
N.C.	2020CPT.I0.09.I0041 2020CPT.I0.09.20041 2020CPT.I0.09.20042	12	
F.A. PROJECT NO.			

PAVEMENT SCHEDULE

(C1)	PROP. APPROX. 2.0" ASPHALT CONC. SURFACE COURSE, TYPE S9.5C, AT AN AVERAGE RATE OF 224 LBS. PER SQ. YD.
(C2)	PROP. APPROX. 1.5" ASPHALT CONC. SURFACE COURSE, TYPE S9.5C, AT AN AVERAGE RATE OF 168 LBS. PER SQ. YD.
(C3)	PROP. APPROX. 1.0" ASPHALT CONC. SURFACE COURSE, TYPE S9.5B, AT AN AVERAGE RATE OF 110 LBS. PER SQ. YD.
(C4)	PROP. ASPHALT SURFACE TREATMENT, DOUBLE SEAL, (SEE S. P. FOR AGGREGATE TYPE.)
(D1)	PROPOSED 2.5" ASPHALT CONC. INTERMEDIATE COURSE, TYPE I19.0C, AT AN AVERAGE RATE OF 285 LBS. PER SQ. YD.
(D2)	AST MAT COAT # 67
(E1)	PROP. APPROX. 5" ASPHALT BASE COURSE, TYPE B25.0C, AT AN AVERAGE RATE OF 570 LBS PER SQYD.
(T1)	SHOULDER RECONSTRUCTION
(T2)	SHOULDER CONSTRUCTION
(V1)	MILLING EXISTING ASPHALT, 1.5" DEPTH
(V2)	PROFILE MILLING EXISTING PAVEMENT, 0-1.5"
(V3)	MILLING EXISTING PAVEMENT, 5" IN DEPTH. (SEE S.P. FOR "TRENCHING FOR BASE COURSE BY MILLING.")
(U)	EXISTING PAVEMENT
(Z)	FULL DEPTH RECLAMATION

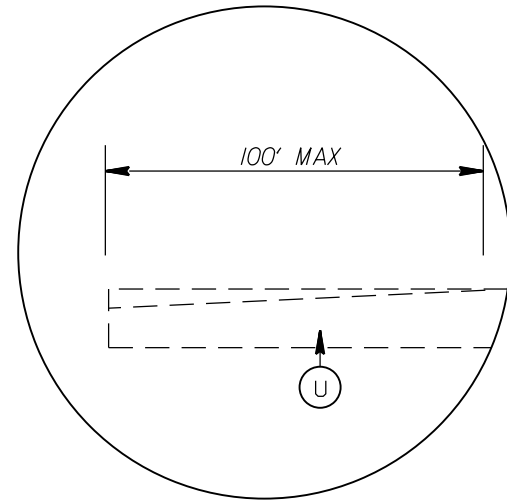

DETAIL FOR INCIDENTAL MILLING (0" TO 2.0")

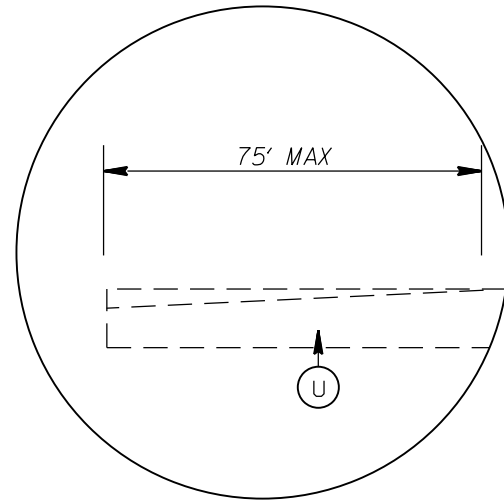

DETAIL FOR INCIDENTAL MILLING (0" TO 1.5")

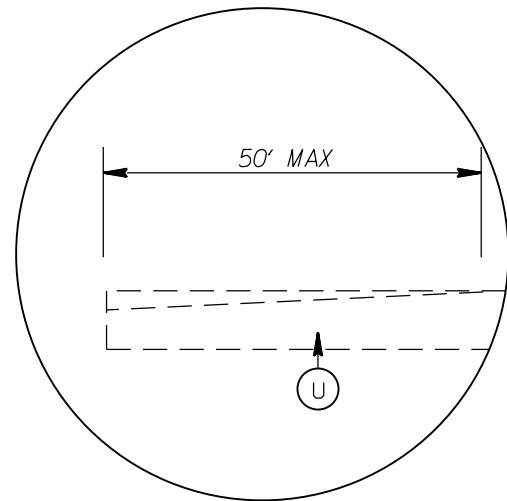

DETAIL FOR INCIDENTAL MILLING (0" TO 1.0")

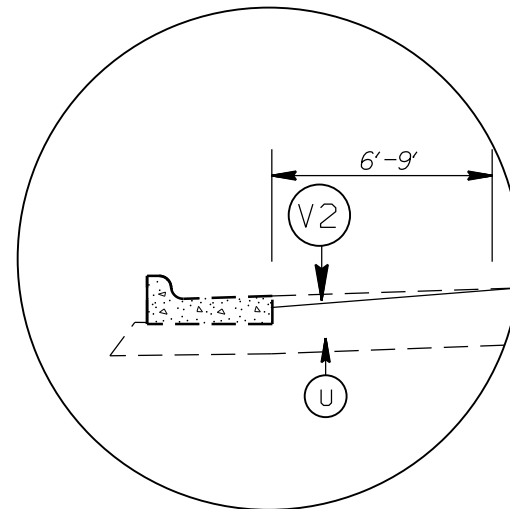

DETAIL FOR PROFILE MILLING

PATCHING DETAIL

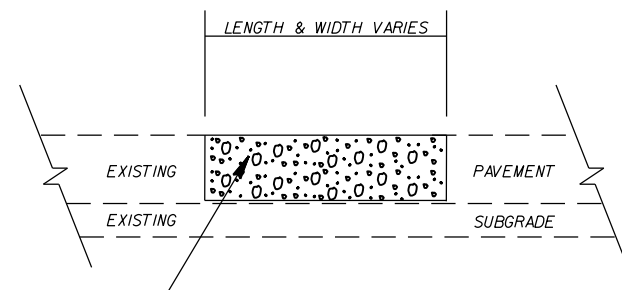

RATE IS VARIABLE AND SHALL BE AS DIRECTED BY THE ENGINEER. ASPHALT TYPE I19.0C SHALL BE PLACED.

2019-2020
ANSON COUNTY RESURFACING

SCALE	-NA-		REVISIONS
DATE	08/18		
DWG. BY	AMO		
DESIGN BY	AMO		
APPROVED	CLA		