

**This electronic collection of documents is provided  
for the convenience of the user  
and is Not a Certified Document –**

**The documents contained herein were originally issued  
and sealed by the individuals whose names and license  
numbers appear on each page, on the dates appearing  
with their signature on that page.**

**This file or an individual page  
shall not be considered a certified document.**

**STATE OF NORTH CAROLINA  
DIVISION OF HIGHWAYS  
CROSS-SECTION SUMMARY**

PROJ. REFERENCE NO.		SHEET NO.
B-4833		X-1A
STATE PROJ. NO.	F.A. PROJ. NO.	DESCRIPTION
38603.1.FD.1	BRZ-2761 (1)	PE, UTIL.
17BP.5.R.96	N/A	R/W, CONST.



**RAMEY KEMP  
&  
ASSOCIATES**

5808 Faringdon Place, Suite 100  
Raleigh • North Carolina • 27609  
Phone (919) 872-5115

NOTE: EMBANKMENT COLUMN DOES NOT INCLUDE BACKFILL FOR UNDERCUT

Station L	Uncl. Exc. (cu. yd.)	Embt (cu. yd.)	Station L	Uncl. Exc. (cu. yd.)	Embt (cu. yd.)
10+36.46	0	0			
10+50.00	3	1			
11+00.00	32	11			
11+50.00	47	18			
12+00.00	42	32			
12+50.00	19	70			
13+00.00	8	121			
13+50.00	30	175			
14+00.00	44	210			
14+50.00	38	200			
15+00.00	65	166			
15+50.00	64	118			
16+00.00	30	79			
16+50.00	20	76			
17+00.00	19	86			
17+50.00	20	69			
18+00.00	24	62			
18+27.88	8	41			
18+30.00	0	2			
19+00.00	0	0			
19+00.13	0	0			
19+50.00	0	114			
20+00.00	0	110			
20+50.00	0	87			
21+00.00	6	68			
21+50.00	26	37			
22+00.00	51	13			
22+50.00	57	9			
23+00.00	46	6			
23+18.17	7	1			

**Approximate quantities only. Unclassified excavation, borrow excavation, fine grading, clearing and grubbing, and removal of existing pavement will be paid for at the lump sum price for "Grading".**

6/23/16



PROJECT REFERENCE NO. B-4833		SHEET NO. X-1
STATE PROJ. NO. 38603.1.FD1 17BP.5.R.96	F. A. PROJ. NO. BRZ-2761 (1) N/A	DESCRIPTION PE, UTIL. R /W, CONST.

**RAMEY KEMP ASSOCIATES, INC.**  
 Transportation Engineers  
 5808 Faringdon Place, Suite 100  
 Raleigh, North Carolina 27609  
 Phone: 919-872-5115  
 www.rameykemp.com  
 NC License No. C-0910

75 70 65 60 55 50 45 40 35 30 25 20 15 10 5 0 5 10 15 20 25 30 35 40 45 50 55

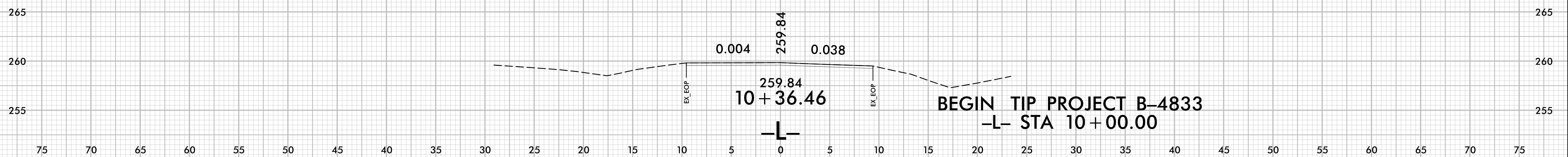
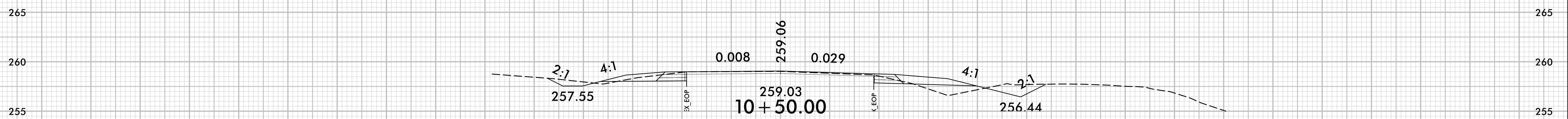
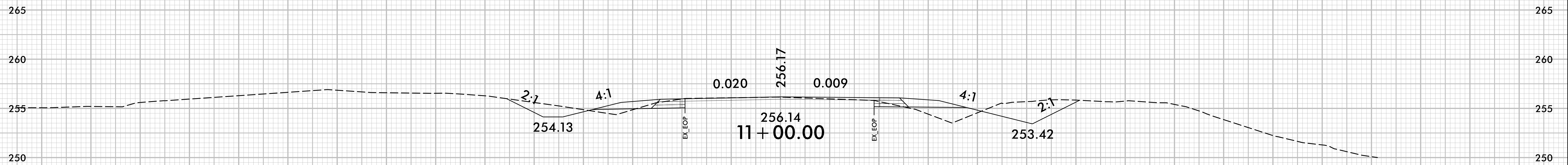
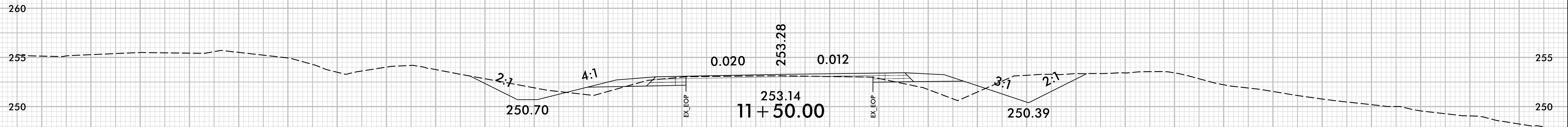

75 70 65 60 55 50 45 40 35 30 25 20 15 10 5 0 5 10 15 20 25 30 35 40 45 50 55 60 65 70 75

6/29/2018  
I:\Roadway\XSC\B4833\_Rdy\_xpl.dgn  
User: ssal1

6/23/16



PROJECT REFERENCE NO.		SHEET NO.
B-4833		X-2
STATE PROJ. NO.	F. A. PROJ. NO.	DESCRIPTION
38603.1.FD1	BRZ-2761 (1)	PE, UTIL.
17BP.5.R.96	N/A	R/W, CONST.

**RAMEY KEMP ASSOCIATES, INC.**  
 Transportation Engineers  
 5808 Faringdon Place, Suite 100  
 Raleigh, North Carolina 27609  
 Phone: 919-872-5115  
 www.rameykemp.com  
 NC License No. C-0910

75 70 65 60 55 50 45 40 35 30 25 20 15 10 5 0 5 10 15 20 25 30 35 40 45 50 55 60

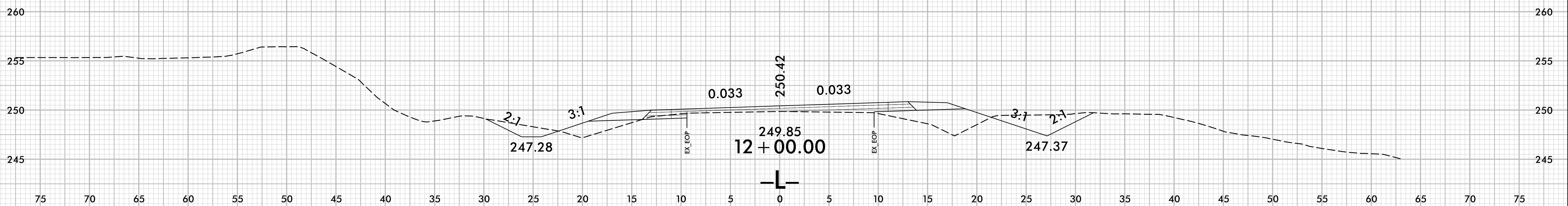
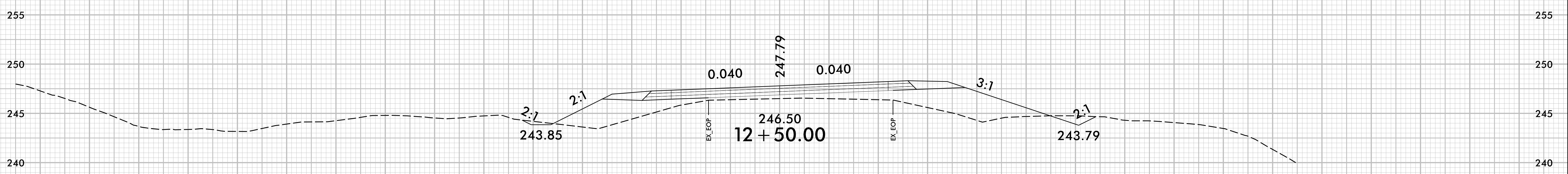
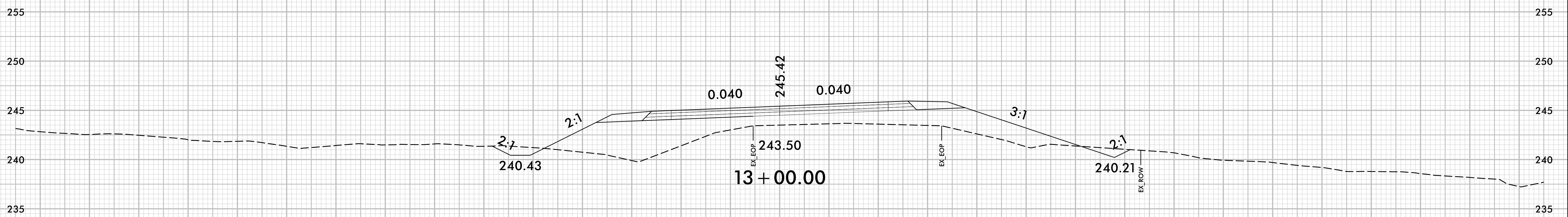

6/29/2018  
I:\Roadway\XSC\B4833\_Rdy\_xpl.dgn  
User: ssal1

75 70 65 60 55 50 45 40 35 30 25 20 15 10 5 0 5 10 15 20 25 30 35 40 45 50 55 60 65 70 75

6/23/16



PROJECT REFERENCE NO.		SHEET NO.
B-4833		X-3
STATE PROJ. NO.	F. A. PROJ. NO.	DESCRIPTION
38603.1.FD1	BRZ-2761 (1)	PE, UTIL.
17BP.5.R.96	N/A	R /W, CONST.

**RAMEY KEMP ASSOCIATES, INC.**  
 Transportation Engineers  
 5808 Faringdon Place, Suite 100  
 Raleigh, North Carolina 27609  
 Phone: 919-872-5115  
 www.rameykemp.com  
 NC License No. C-0910

75 70 65 60 55 50 45 40 35 30 25 20 15 10 5 0 5 10 15 20 25 30 35 40 45 50 55 60

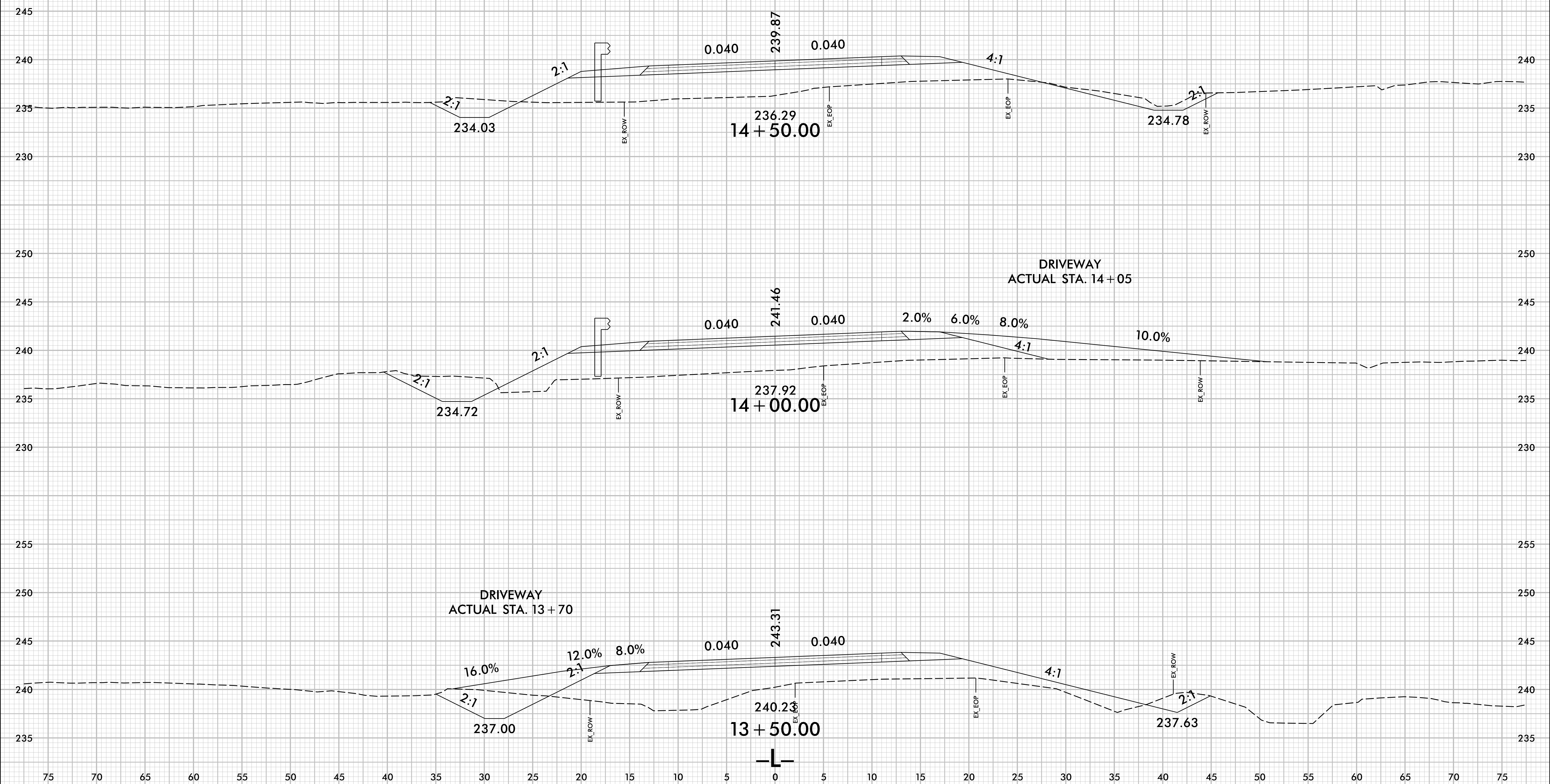

75 70 65 60 55 50 45 40 35 30 25 20 15 10 5 0 5 10 15 20 25 30 35 40 45 50 55 60 65 70 75

6/29/2018  
 I:\Roadway\XSC\B4833\_Rdy\_xpl.dgn  
 User: ssal1

6/23/16

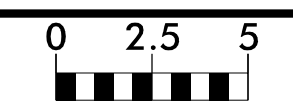

PROJECT REFERENCE NO.		SHEET NO.
B-4833		X-4
STATE PROJ. NO.	F. A. PROJ. NO.	DESCRIPTION
38603.1.FD1	BRZ-2761 (1)	PE, UTIL.
17BP.5.R.96	N/A	R/W, CONST.

**RAMEY KEMP ASSOCIATES, INC.**  
 Transportation Engineers  
 5808 Faringdon Place, Suite 100  
 Raleigh, North Carolina 27609  
 Phone: 919-872-5115  
 www.rameykemp.com  
 NC License No. C-0910

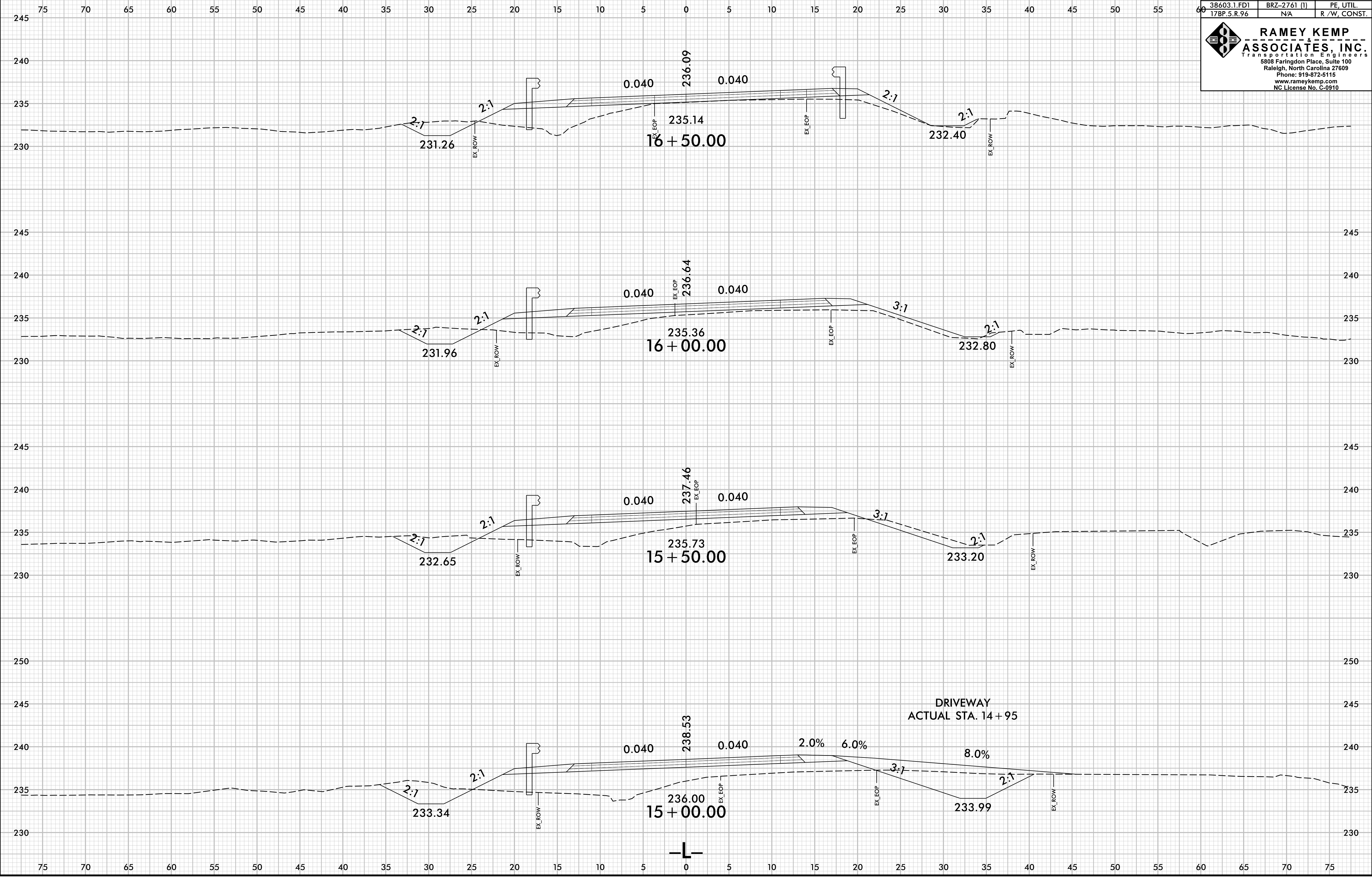

6/29/2018  
 I:\Roadway\XSC\B4833\_Rdy\_xpl.dgn  
 User: ssal1

6/23/16



PROJECT REFERENCE NO. B-4833		SHEET NO. X-5
STATE PROJ. NO. 38603.1.FD1 17BP.5.R.96	F. A. PROJ. NO. BRZ-2761 (1) N/A	DESCRIPTION PE, UTIL. R/W, CONST.

**RAMEY KEMP ASSOCIATES, INC.**  
 Transportation Engineers  
 5808 Faringdon Place, Suite 100  
 Raleigh, North Carolina 27609  
 Phone: 919-872-5115  
 www.rameykemp.com  
 NC License No. C-0910

75 70 65 60 55 50 45 40 35 30 25 20 15 10 5 0 5 10 15 20 25 30 35 40 45 50 55 60

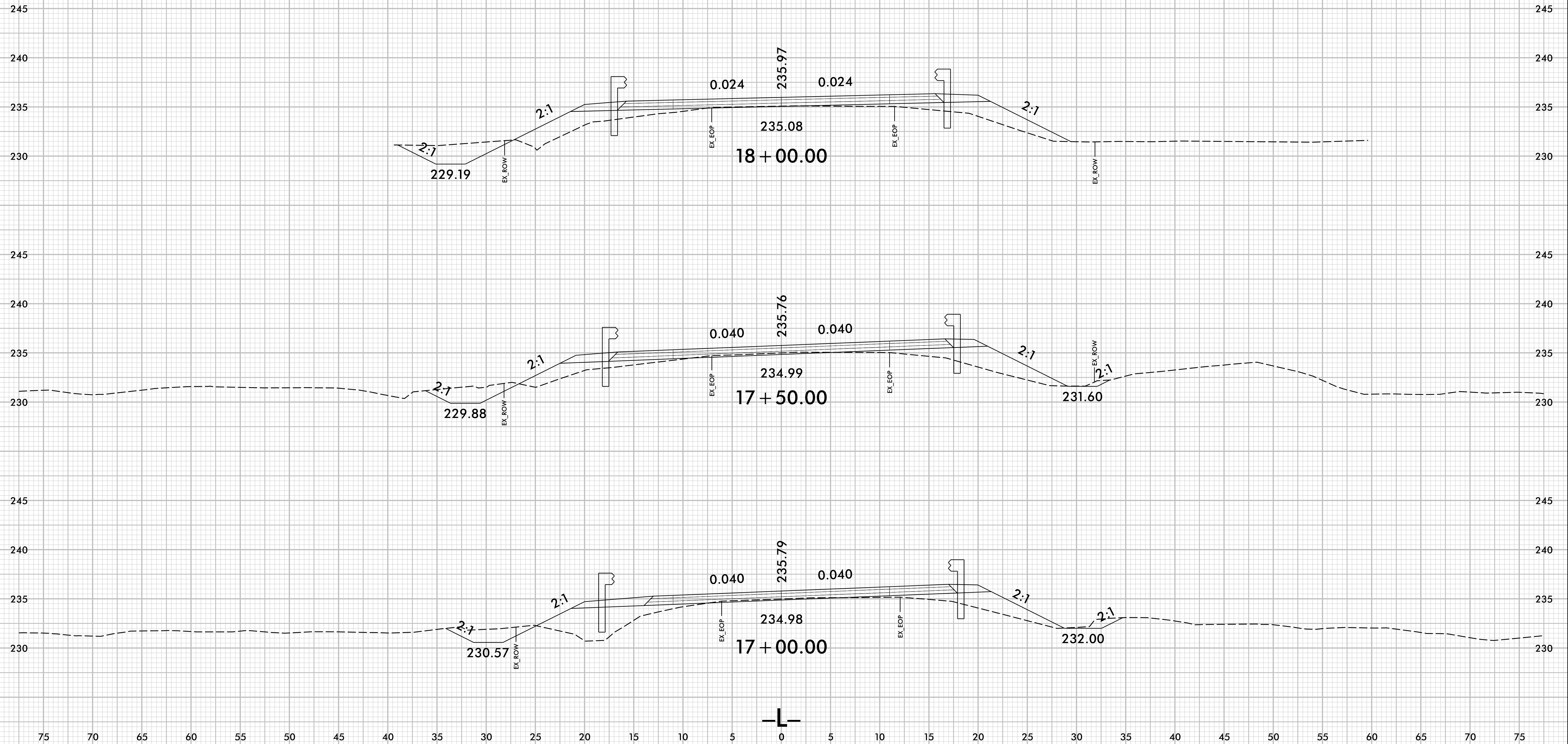

6/23/2018  
I:\Roadway\XSC\B4833\_Rdy\_xpl.dgn  
User: ssal108

75 70 65 60 55 50 45 40 35 30 25 20 15 10 5 0 5 10 15 20 25 30 35 40 45 50 55 60 65 70 75

6/23/16



PROJECT REFERENCE NO. B-4833		SHEET NO. X-6
STATE PROJ. NO. 38603.1.FD1 17BP.5.R.96	F. A. PROJ. NO. BRZ-2761 (1) N/A	DESCRIPTION PE, UTIL. R/W, CONST.

**RAMEY KEMP ASSOCIATES, INC.**  
 Transportation Engineers  
 5808 Faringdon Place, Suite 100  
 Raleigh, North Carolina 27609  
 Phone: 919-872-5115  
 www.rameykemp.com  
 NC License No. C-0910

75 70 65 60 55 50 45 40 35 30 25 20 15 10 5 0 5 10 15 20 25 30 35 40 45 50 55 60

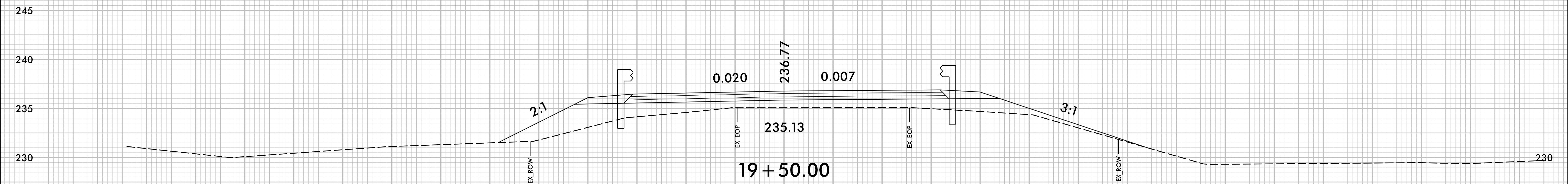

**END BRIDGE NO. 376**  
**-L- STA 19 + 00.13**

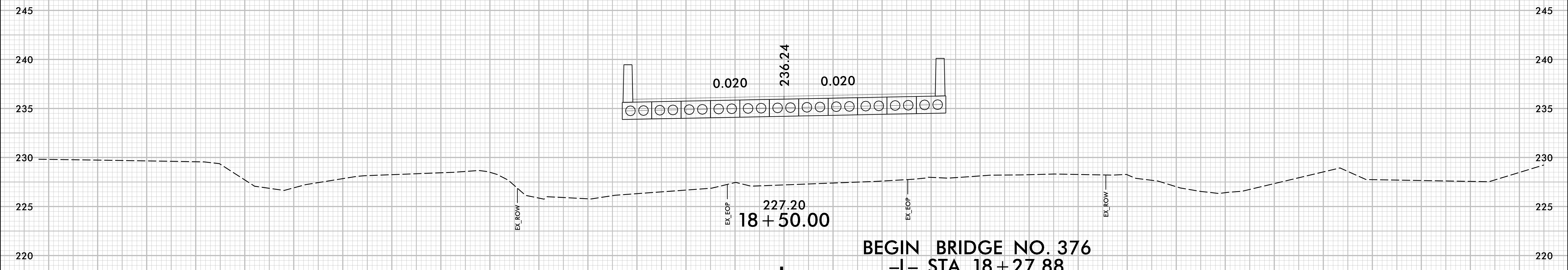
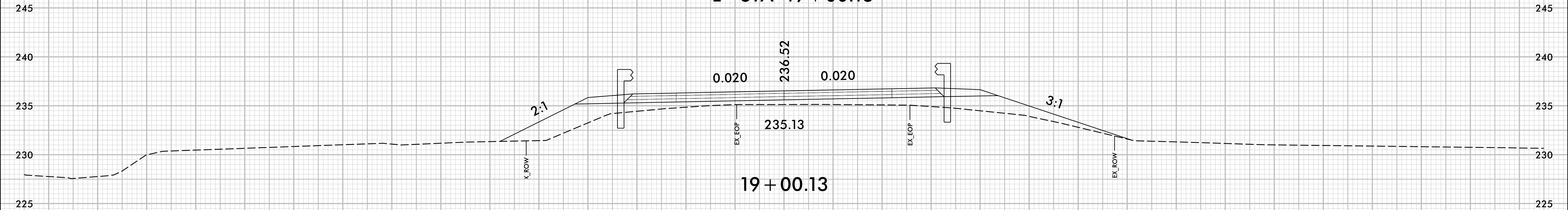

**BEGIN BRIDGE NO. 376**  
**-L- STA 18 + 27.88**

75 70 65 60 55 50 45 40 35 30 25 20 15 10 5 0 5 10 15 20 25 30 35 40 45 50 55 60 65 70 75

6/23/2018  
I:\Roadway\XSC\B4833\_Rdy\_xpl.dgn  
User: ssal1



6/23/16



PROJECT REFERENCE NO.		SHEET NO.
B-4833		X-7
STATE PROJ. NO.	F. A. PROJ. NO.	DESCRIPTION
38603.1.FD1	BRZ-2761 (1)	PE, UTIL.
17BP.5.R.96	N/A	R/W, CONST.

**RAMEY KEMP ASSOCIATES, INC.**  
 Transportation Engineers  
 5808 Faringdon Place, Suite 100  
 Raleigh, North Carolina 27609  
 Phone: 919-872-5115  
 www.rameykemp.com  
 NC License No. C-0910

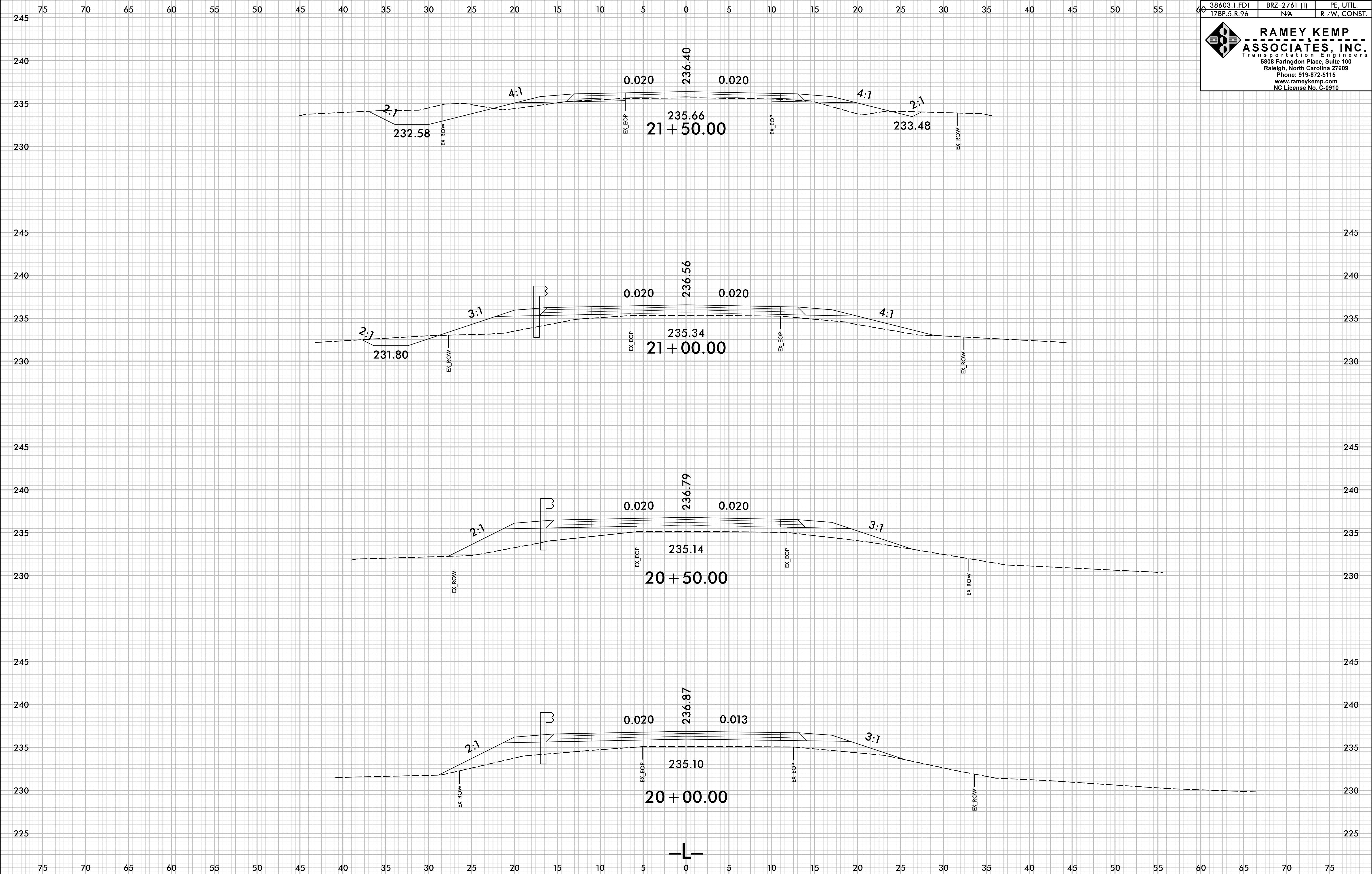

6/23/2018  
I:\Roadway\XSC\B4833\_Rdy\_xpl.dgn  
User: ssal1

6/23/16



PROJECT REFERENCE NO.		SHEET NO.
B-4833		X-8
STATE PROJ. NO.	F. A. PROJ. NO.	DESCRIPTION
38603.1.FD1	BRZ-2761 (1)	PE, UTIL.
17BP.5.R.96	N/A	R/W, CONST.

**RAMEY KEMP ASSOCIATES, INC.**  
 Transportation Engineers  
 5808 Faringdon Place, Suite 100  
 Raleigh, North Carolina 27609  
 Phone: 919-872-5115  
 www.rameykemp.com  
 NC License No. C-0910

**END TIP PROJECT B-4833**  
**-L- STA 23+70.00**

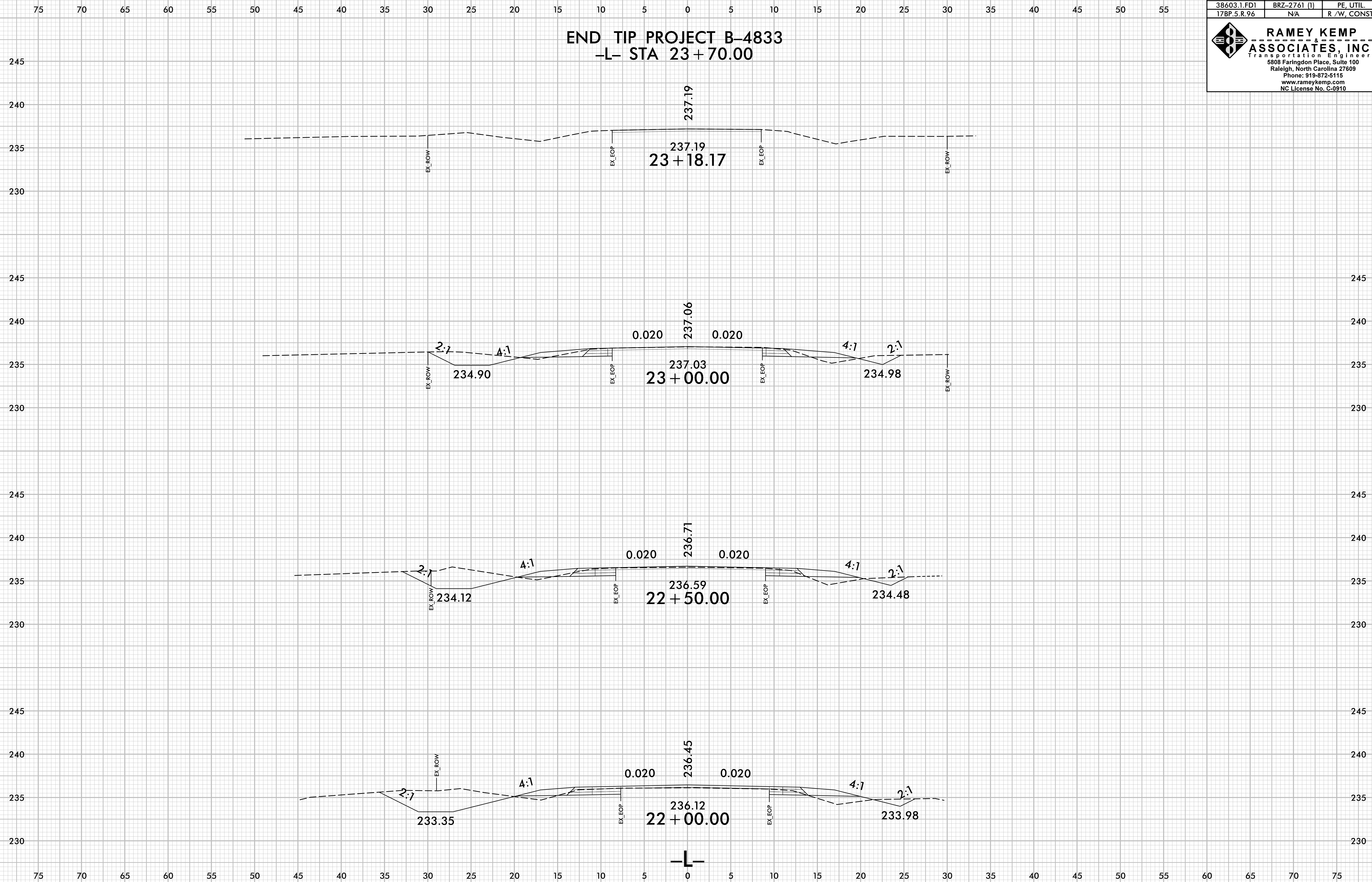

6/23/2018  
I:\Roadway\XSC\B4833\_Rdy\_xpl.dgn  
User: ssal