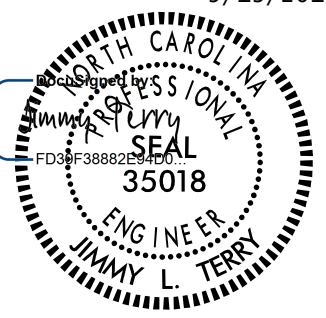

**This electronic collection of documents is provided
for the convenience of the user
and is Not a Certified Document –**

**The documents contained herein were originally issued
and sealed by the individuals whose names and license
numbers appear on each page, on the dates appearing
with their signature on that page.**

**This file or an individual page
shall not be considered a certified document.**

TIP NO.	SHEET NO.
W-5212N	PMP-1
APPROVED: _____	
DATE: _____	
SEAL 9/13/2018 5:49:03 AM PDT	
	
DOCUMENT NOT CONSIDERED FINAL UNLESS ALL SIGNATURES COMPLETED	

**STATE OF NORTH CAROLINA
DEPARTMENT OF TRANSPORTATION**

**PAVEMENT MARKING PLAN
GASTON COUNTY**

**LOCATION: NC 279 (DALLAS CHERRYVILLE HWY)
FROM SOUTH OF SR 1438 (ST MARK'S CHURCH RD) TO NORTH OF NC 275**

T.I.P.: W-5212N

CONTRACT: DL00183

ROADWAY STANDARD DRAWING

THE FOLLOWING ROADWAY STANDARDS AS APPEAR IN "ROADWAY STANDARD DRAWINGS" - PROJECT SERVICES UNIT - N.C. DEPARTMENT OF TRANSPORTATION - RALEIGH, N.C., DATED JANUARY 2018 ARE APPLICABLE TO THIS PROJECT AND BY REFERENCE HEREBY ARE CONSIDERED A PART OF THESE PLANS:

STD. NO.	TITLE
1205.01	PAVEMENT MARKINGS - LINE TYPES AND OFFSETS
1205.02	PAVEMENT MARKINGS - TWO-LANE AND MULTILANE ROADWAYS
1205.04	PAVEMENT MARKINGS - INTERSECTIONS
1205.05	PAVEMENT MARKINGS - TURN LANES
1205.08	PAVEMENT MARKINGS - SYMBOLS AND WORD MESSAGES
1205.09	PAVEMENT MARKINGS - PAINTED ISLANDS
1205.13	PAVEMENT MARKINGS - LANE REDUCTIONS
1250.01	RAISED PAVEMENT MARKERS - INSTALLATION SPACING
1253.01	RAISED PAVEMENT MARKERS - SNOWPLOWABLE
1261.01	GUARDRAIL AND BARRIER DELINEATORS - INSTALLATION SPACING
1261.02	GUARDRAIL AND BARRIER DELINEATORS - TYPES AND MOUNTING
1262.01	GUARDRAIL END DELINEATION
1264.01	OBJECT MARKERS - TYPES
1264.02	OBJECT MARKERS - INSTALLATION

GENERAL NOTES

THE FOLLOWING GENERAL NOTES APPLY AT ALL TIMES FOR THE DURATION OF THE CONSTRUCTION PROJECT, EXCEPT WHEN OTHERWISE NOTED IN THE PLAN, OR DIRECTED BY THE ENGINEER.

- A) INSTALL PAVEMENT MARKINGS AND PAVEMENT MARKERS ON THE FINAL SURFACE AS FOLLOWS:

ROAD NAME	MARKING	MARKER
NC 279 (-L-)	THERMOPLASTIC	SNOWPLOWABLE RAISED
- B) TIE PROPOSED PAVEMENT MARKING LINES TO EXISTING PAVEMENT MARKING LINES.
- C) REMOVE/REPLACE ANY CONFLICTING/DAMAGED PAVEMENT MARKINGS AND MARKERS.
- D) UNLESS OTHERWISE SPECIFIED, HEATED-IN-PLACE THERMOPLASTIC MAY BE USED IN LIEU OF EXTRUDED THERMOPLASTIC FOR STOP BARS, SYMBOLS, CHARACTERS AND DIAGONALS. IF HEATED-IN-PLACE IS USED, IT SHALL BE PAID FOR USING THE EXTRUDED THERMOPLASTIC PAY ITEM.

INDEX

SHEET NO.	DESCRIPTION
PMP-1	PAVEMENT MARKING PLAN TITLE, INDEX OF SHEETS, LIST OF APPLICABLE ROADWAY STANDARD DRAWINGS, GENERAL NOTES AND FINAL PAVEMENT MARKING SCHEDULE
PMP-2 TO PMP-13	FINAL PAVEMENT MARKING PLAN

FINAL PAVEMENT MARKING SCHEDULE

SYMBOL	DESCRIPTION	SYMBOL	DESCRIPTION
PAVEMENT MARKINGS		THERMOPLASTIC PAVEMENT MARKING SYMBOLS (90 MILS)	
THERMOPLASTIC(12", 90 MILS)		UA	LEFT TURN ARROW
TV	YELLOW DIAGONAL	UD	COMBO STRAIGHT/LEFT
		UP	MERGE ARROW
THERMOPLASTIC(24", 120 MILS)		MARKERS	
T2	WHITE STOPBAR	SNOWPLOWABLE RAISED PAVEMENT MARKERS	
THERMOPLASTIC(4", 120 MILS)		ME	YELLOW & YELLOW
T8	2 FT. - 6 FT./SP WHITE MINISKIP	MF	CRYSTAL & RED
TC	10 FT. WHITE SKIP	NOTE: SEE NCDOT RDY DWG 1250.01 FOR MARKERS LAYOUT AND SPACING	
TD	3 FT. - 9 FT./SP WHITE MINISKIP		
TE	WHITE SOLID LANE LINE		
TF	10 FT. YELLOW SKIP		
TH	YELLOW SINGLE CENTER		
TI	YELLOW DOUBLE CENTER		
THERMOPLASTIC(4", 90 MILS)			
TA	WHITE EDGELINE		

PLAN PREPARED FOR N.C.D.O.T. BY:



TGS ENGINEERS
804-C N. LAFAYETTE ST
SHELBY, NC 28150
PH (704) 476-0003
CORP. LICENSE NO.: C-0275

JIMMY L. TERRY, PE PROJECT ENGINEER
SANDRA MELVIN DESIGN TECHNICIAN

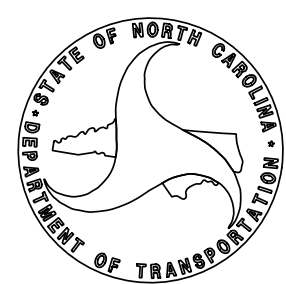

TIP NO.	SHEET NO.
W-5212N	PMP-2
APPROVED:	
DATE:	
SEAL	

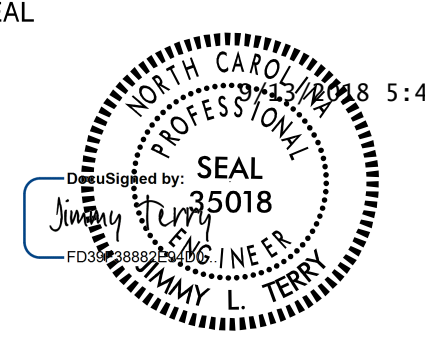

DOCUMENT NOT CONSIDERED FINAL
UNLESS ALL SIGNATURES COMPLETED

TGS ENGINEERS
804-C N. LAFAYETTE ST
SHELBY, NC 28150
PH (704) 476-0003
CORP. LICENSE NO.: C-0275

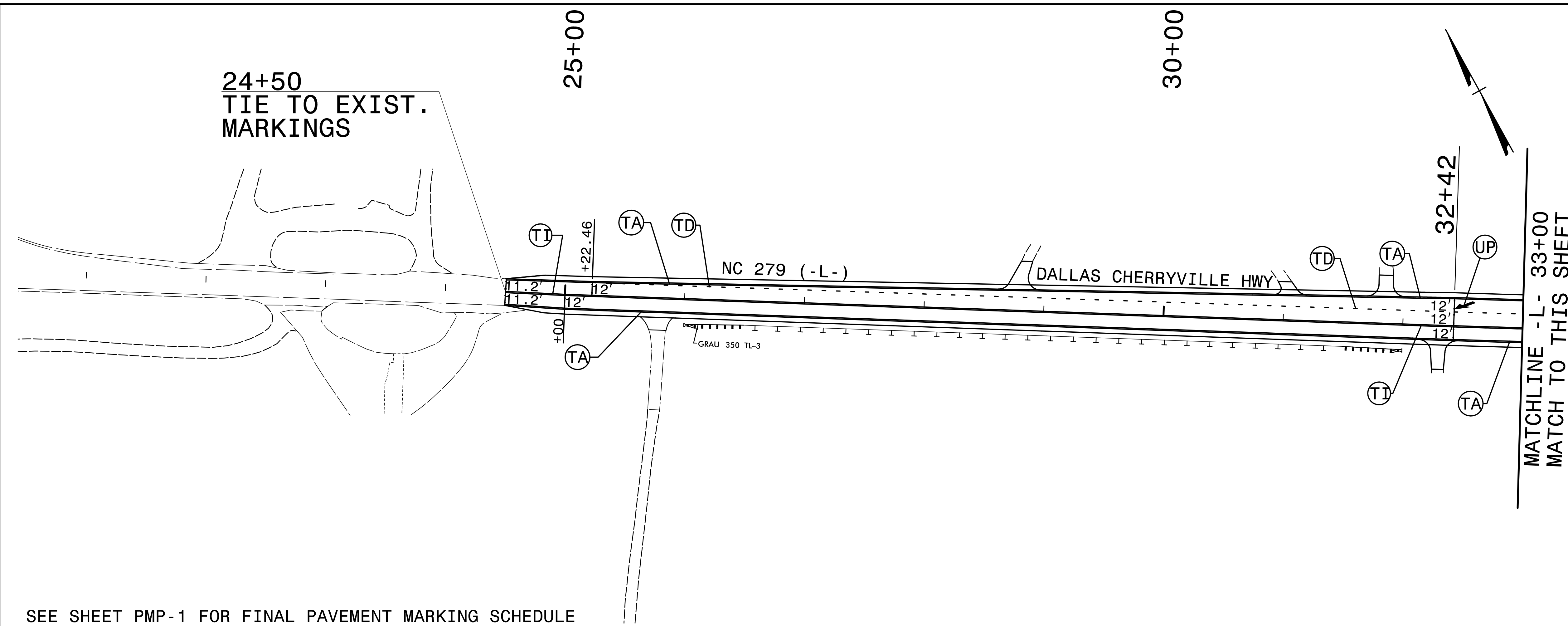

SEE SHEET PMP-1 FOR FINAL PAVEMENT MARKING SCHEDULE

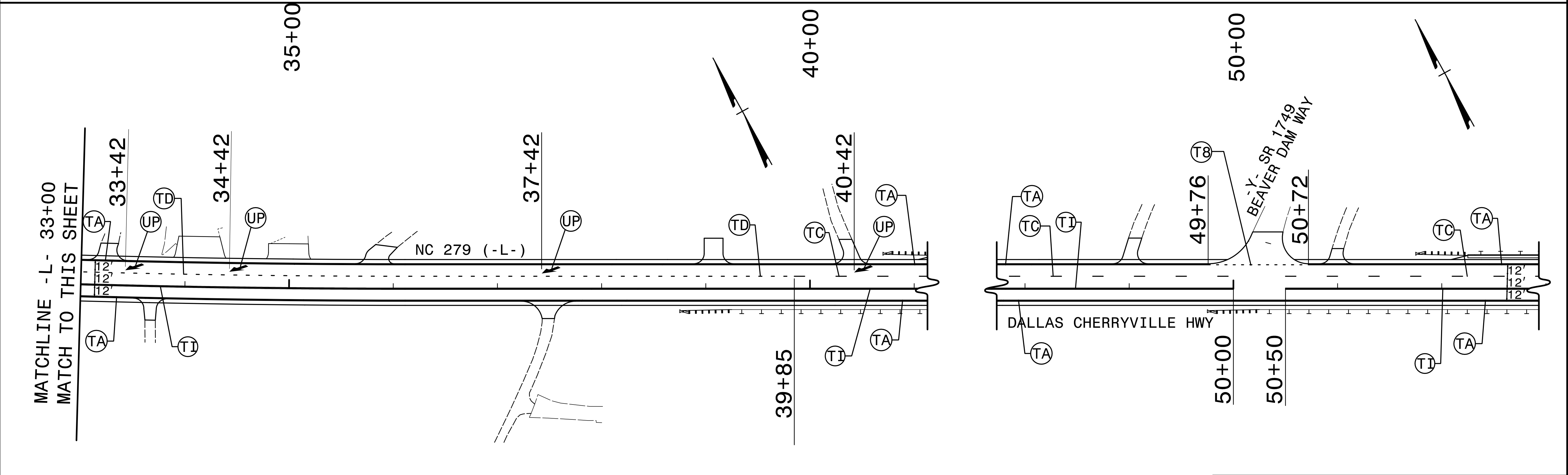

SEE SHEET PMP-1 FOR FINAL PAVEMENT MARKING SCHEDULE

FINAL PAVEMENT MARKING PLAN

9/11/2018 X:\NGD001\W-5212N\Traffic\ Pavement Markings\W-5212N_Sgn_PMP_02.dgn User:smelvin

TIP NO.	SHEET NO.
W-5212N	PMP-3
APPROVED: _____	
DATE: _____	
SEAL	
<p>DOCUMENT NOT CONSIDERED FINAL UNLESS ALL SIGNATURES COMPLETED</p>	
<p>TGS ENGINEERS 804-C N. LAFAYETTE ST SHELBY, NC 28150 PH (704) 476-0003 CORP. LICENSE NO.: C-0275</p>	

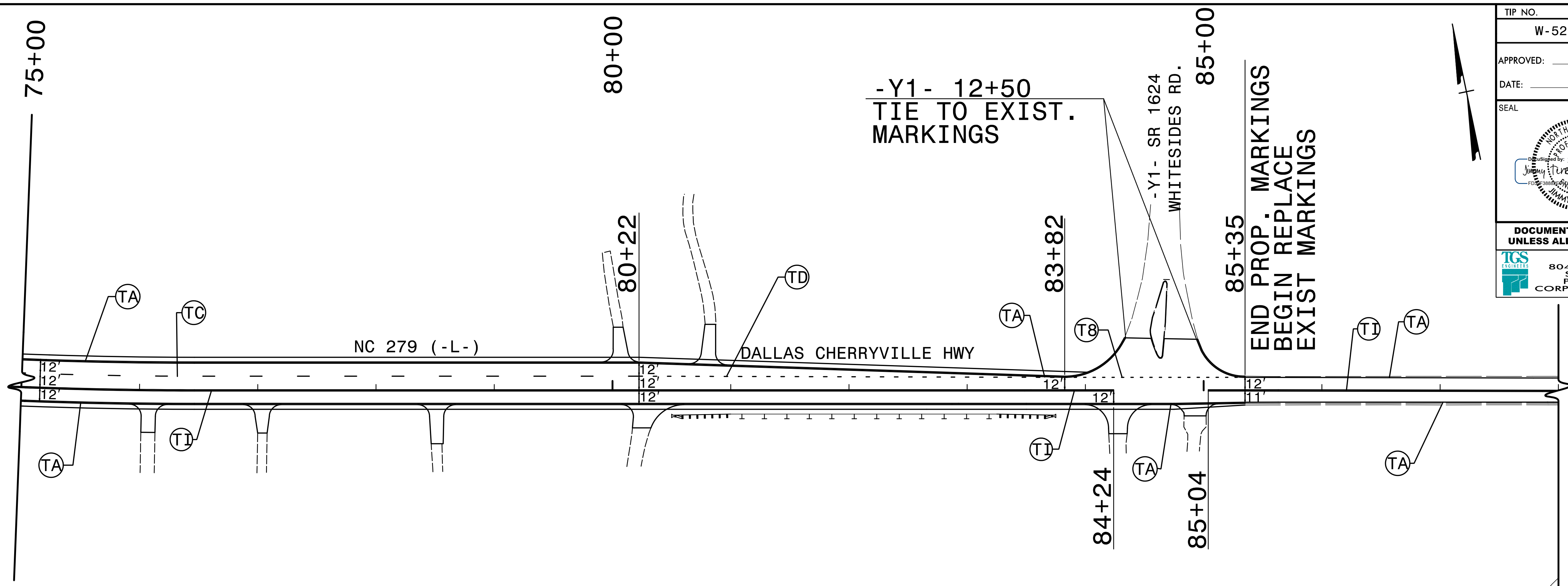

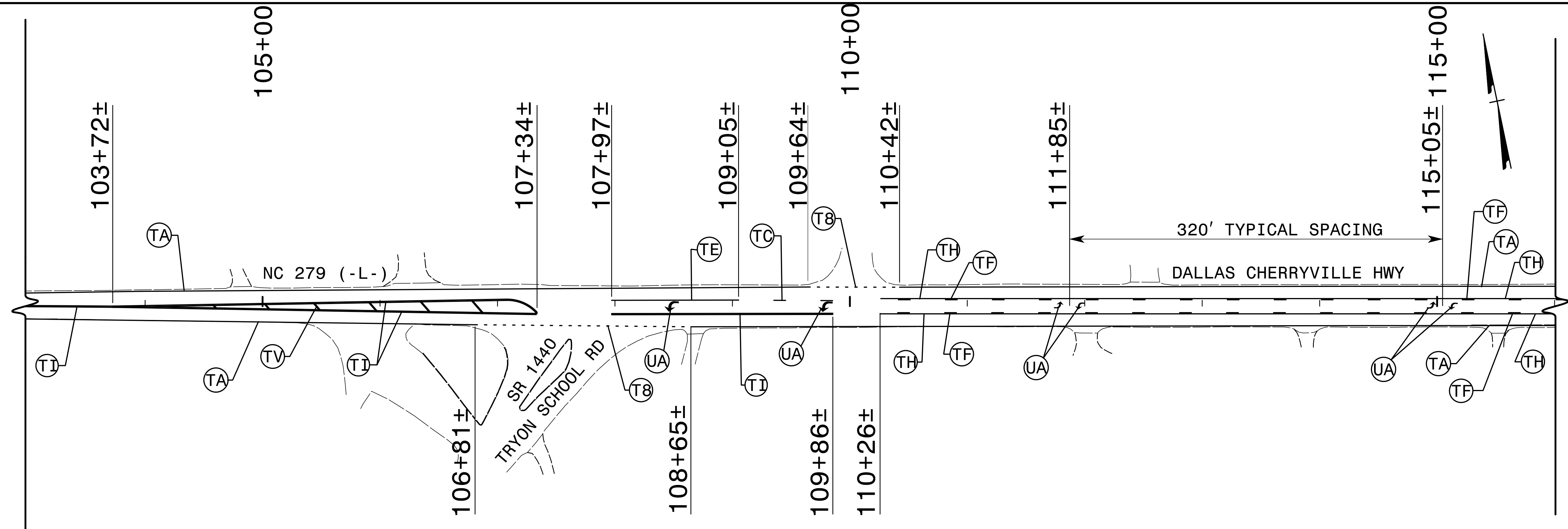

SEE SHEET PMP-1 FOR FINAL PAVEMENT MARKING SCHEDULE



IN AREAS TO BE RESURFACED ONLY REPLACE EXISTING MARKINGS.
 ±STATIONS ARE APPROXIMATIONS ONLY.
 SEE SHEET PMP-1 FOR FINAL PAVEMENT MARKING SCHEDULE

FINAL PAVEMENT MARKING PLAN

9/11/2018
X:\NGDOT\W-5212N\Traffic\ Pavement Markings\W-5212N_Sgn_PMP_03.dgn
User:smelvin

TIP NO.	SHEET NO.
W-5212N	PMP-4
APPROVED: _____	
DATE: _____	
SEAL	
	
<p>DOCUMENT NOT CONSIDERED FINAL UNLESS ALL SIGNATURES COMPLETED</p>	
 <p>TGS ENGINEERS 804-C N. LAFAYETTE ST SHELBY, NC 28150 PH (704) 476-0003 CORP. LICENSE NO.: C-0275</p>	

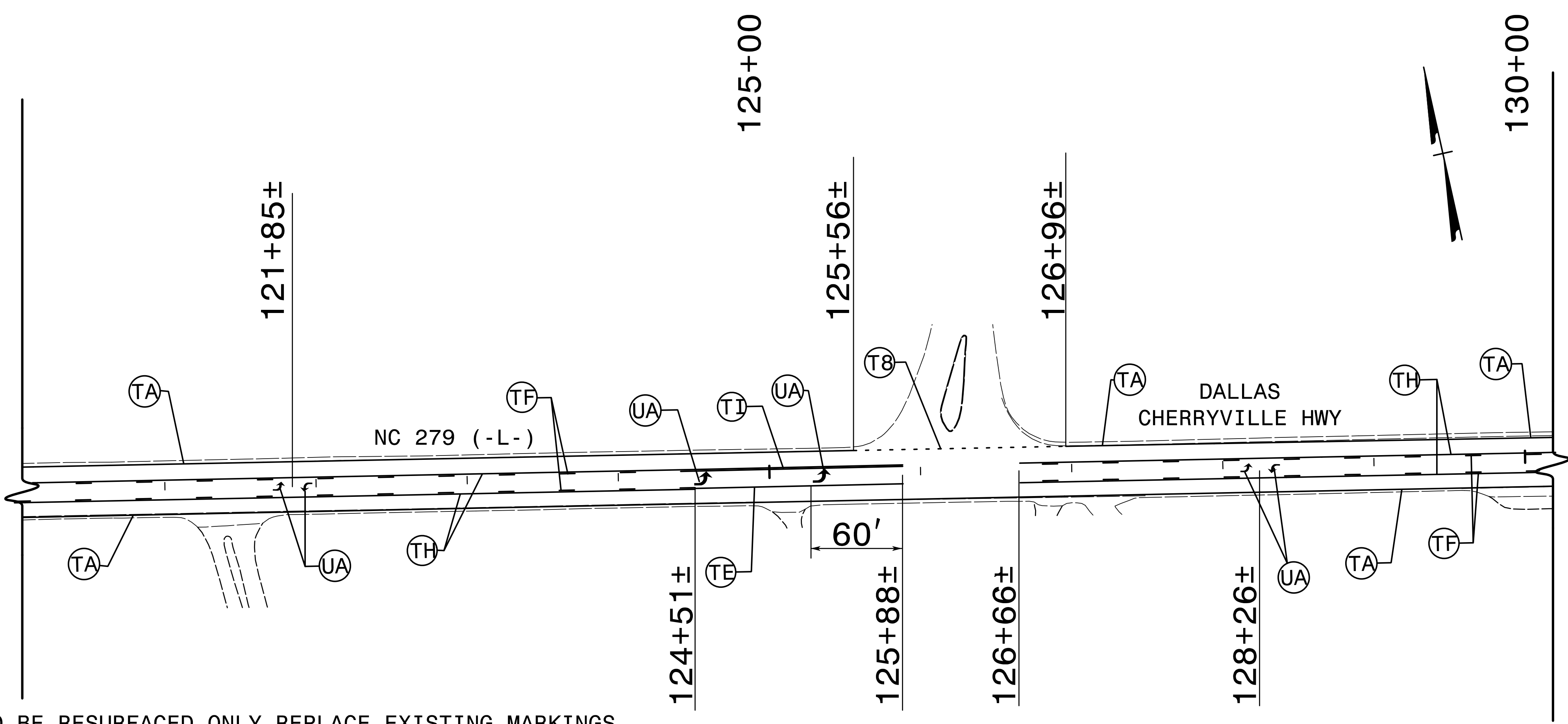

IN AREAS TO BE RESURFACED ONLY REPLACE EXISTING MARKINGS.
±STATIONS ARE APPROXIMATIONS ONLY.
SEE SHEET PMP-1 FOR FINAL PAVEMENT MARKING SCHEDULE

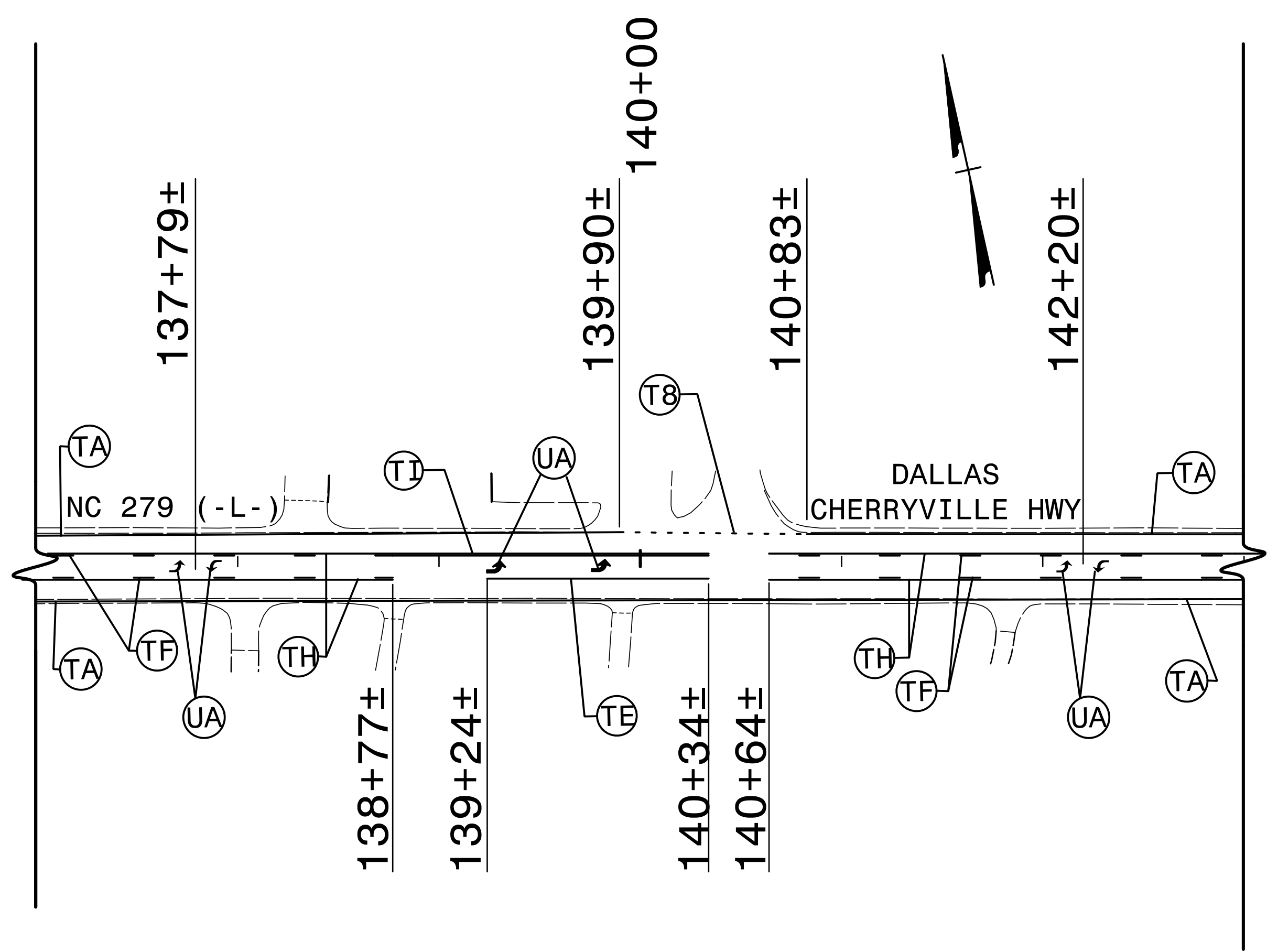

IN AREAS TO BE RESURFACED ONLY REPLACE EXISTING MARKINGS.
±STATIONS ARE APPROXIMATIONS ONLY.
SEE SHEET PMP-1 FOR FINAL PAVEMENT MARKING SCHEDULE

FINAL PAVEMENT MARKING PLAN

9/11/2018 X:\NGDOT\W-5212N\Traffic\ Pavement Markings\W-5212N_Sgn_PMP_04.dgn User:smelvin

TIP NO.	SHEET NO.
W-5212N	PMP-5
APPROVED: _____	
DATE: _____	
SEAL	
<p>DOCUMENT NOT CONSIDERED FINAL UNLESS ALL SIGNATURES COMPLETED</p>	
<p>TGS ENGINEERS 804-C N. LAFAYETTE ST SHELBY, NC 28150 PH (704) 476-0003 CORP. LICENSE NO.: C-0275</p>	

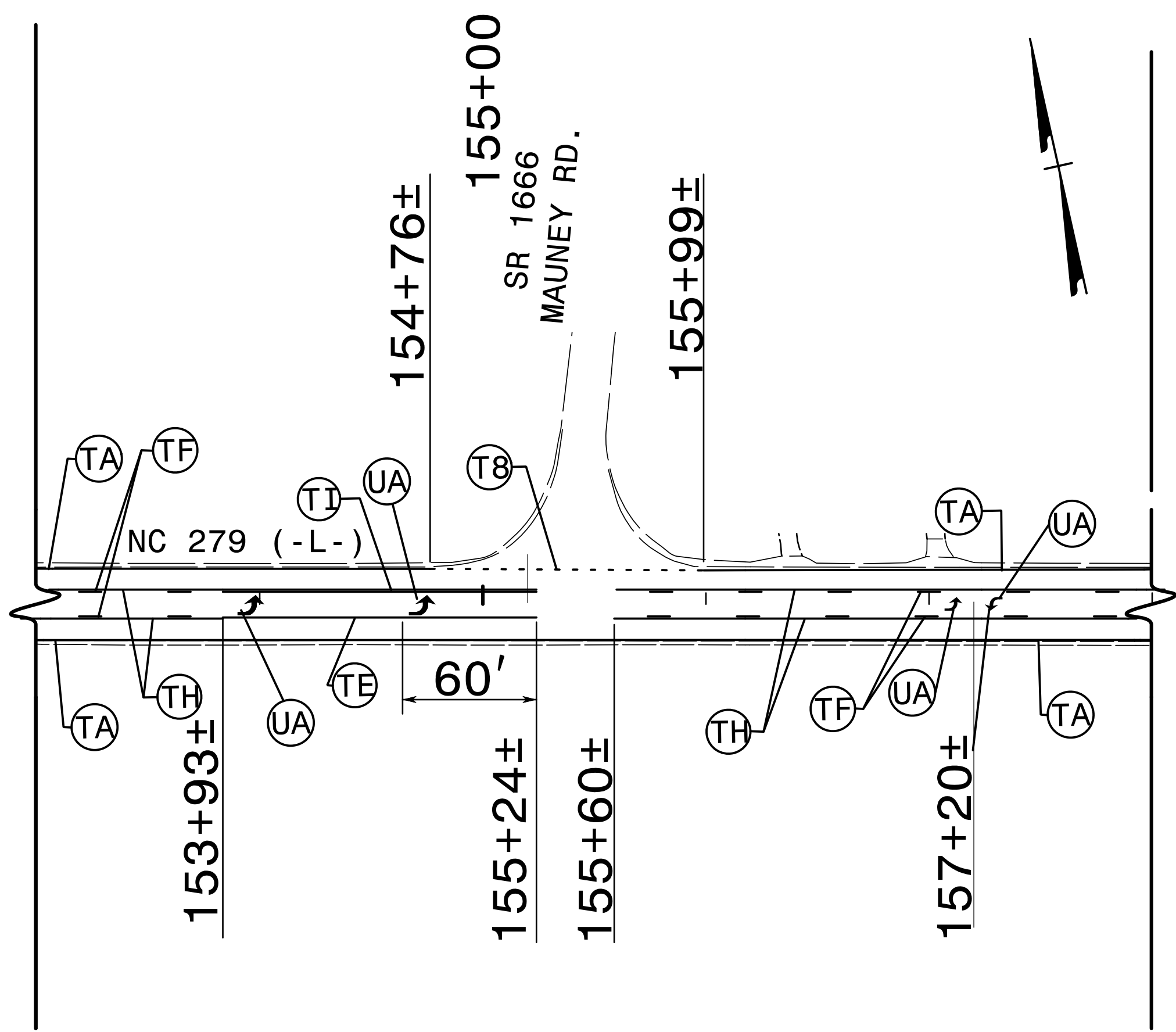

IN AREAS TO BE RESURFACED ONLY REPLACE EXISTING MARKINGS.
±STATIONS ARE APPROXIMATIONS ONLY.
SEE SHEET PMP-1 FOR FINAL PAVEMENT MARKING SCHEDULE

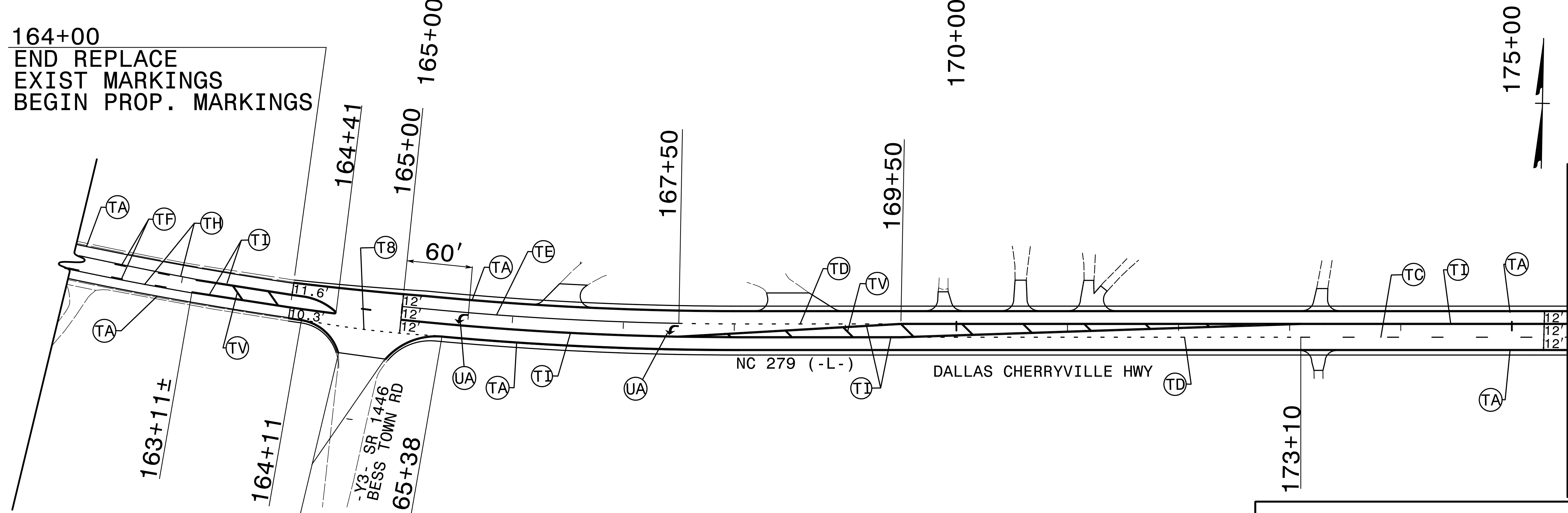

164+00
END REPLACE
EXIST MARKINGS
BEGIN PROP. MARKINGS



-Y3- 10+42
TIE TO EXIST.
MARKINGS

IN AREAS TO BE RESURFACED ONLY REPLACE EXISTING MARKINGS.
±STATIONS ARE APPROXIMATIONS ONLY.
SEE SHEET PMP-1 FOR FINAL PAVEMENT MARKING SCHEDULE

FINAL PAVEMENT MARKING PLAN

MATCHLINE -L- 175+50
MATCH TO SHEET PMP-6

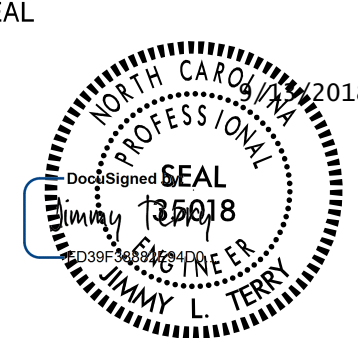
9/11/2018 X:\NGD001\W-5212N\Traffic\Pavement Markings\W-5212N_Sgn_PMP_05.dgn User:smelvin

TIP NO.	SHEET NO.
W-5212N	PMP-7
APPROVED: _____	
DATE: _____	
SEAL	
	
<p>DOCUMENT NOT CONSIDERED FINAL UNLESS ALL SIGNATURES COMPLETED</p>	
 <p>TGS ENGINEERS 804-C N. LAFAYETTE ST SHELBY, NC 28150 PH: (704) 476-0003 CORP. LICENSE NO.: C-0275</p>	

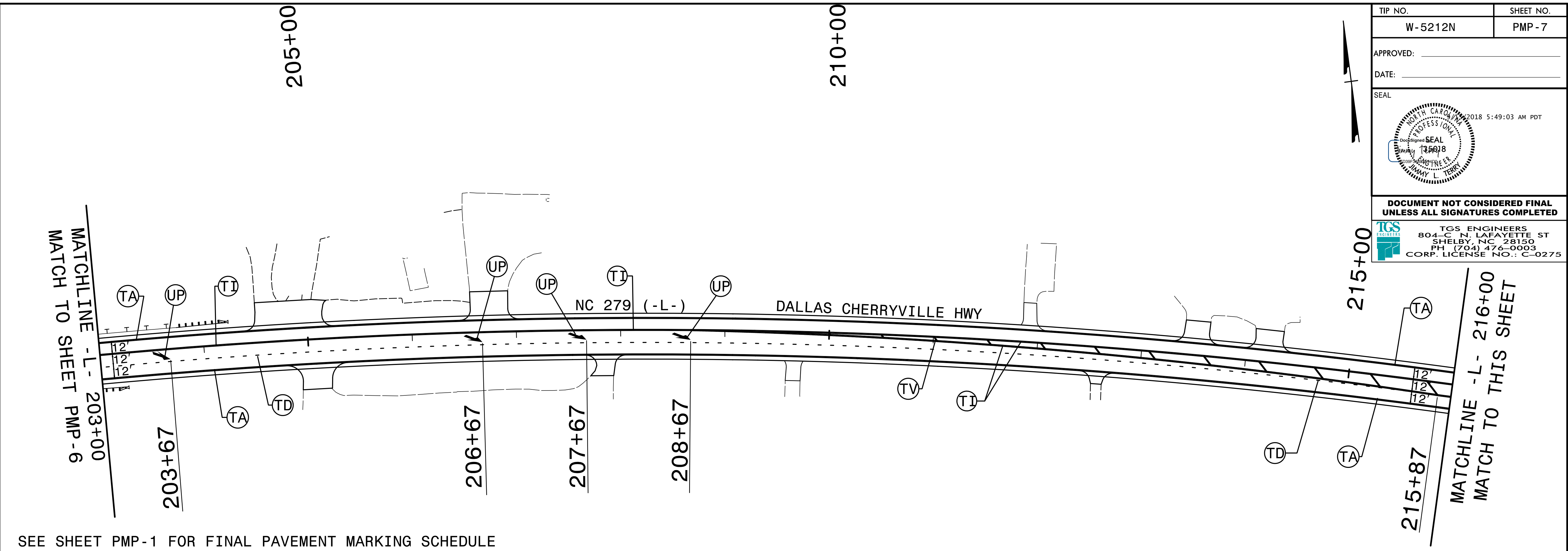

SEE SHEET PMP-1 FOR FINAL PAVEMENT MARKING SCHEDULE

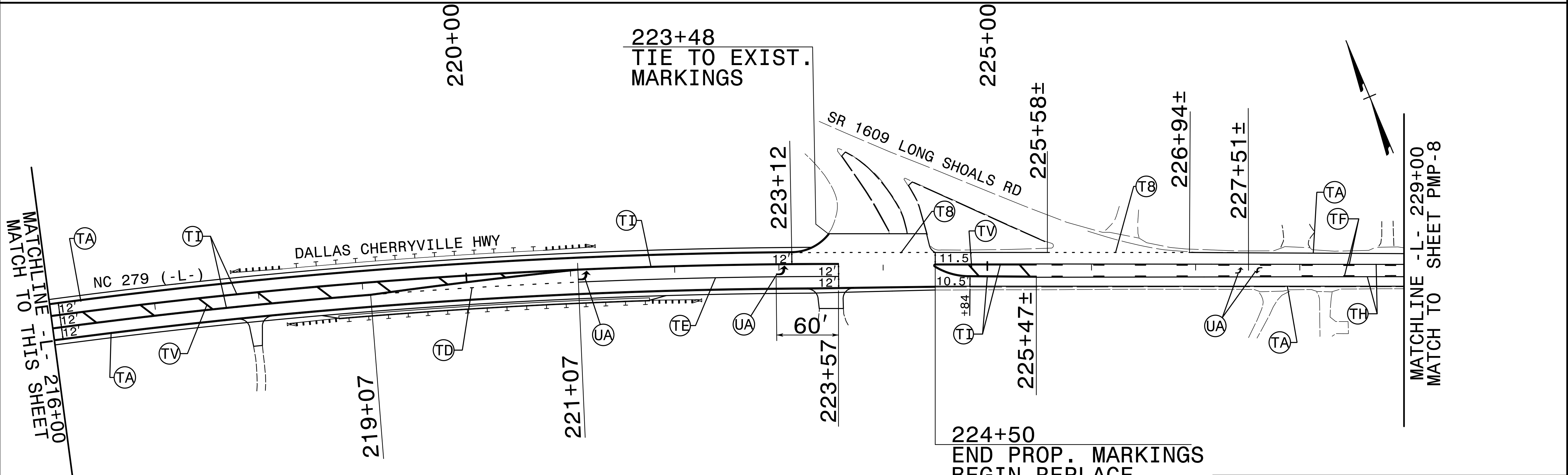

IN AREAS TO BE RESURFACED ONLY REPLACE EXISTING MARKINGS.
 ±STATIONS ARE APPROXIMATIONS ONLY.
 SEE SHEET PMP-1 FOR FINAL PAVEMENT MARKING SCHEDULE

224+50
 END PROP. MARKINGS
 BEGIN REPLACE
 EXIST. MARKINGS

FINAL PAVEMENT MARKING PLAN

9/11/2018
 X:\NGD001\W-5212N\Traffic\ Pavement Markings\W-5212N_Sgn_PMP_07.dgn
 User:smelvin

TIP NO.	SHEET NO.
W-5212N	PMP-8
APPROVED: _____	
DATE: _____	
SEAL	
DOCUMENT NOT CONSIDERED FINAL UNLESS ALL SIGNATURES COMPLETED	
TGS ENGINEERS 804-C N. LAFAYETTE ST SHELBY, NC 28150 PH (704) 476-0003 CORP. LICENSE NO.: C-0275	

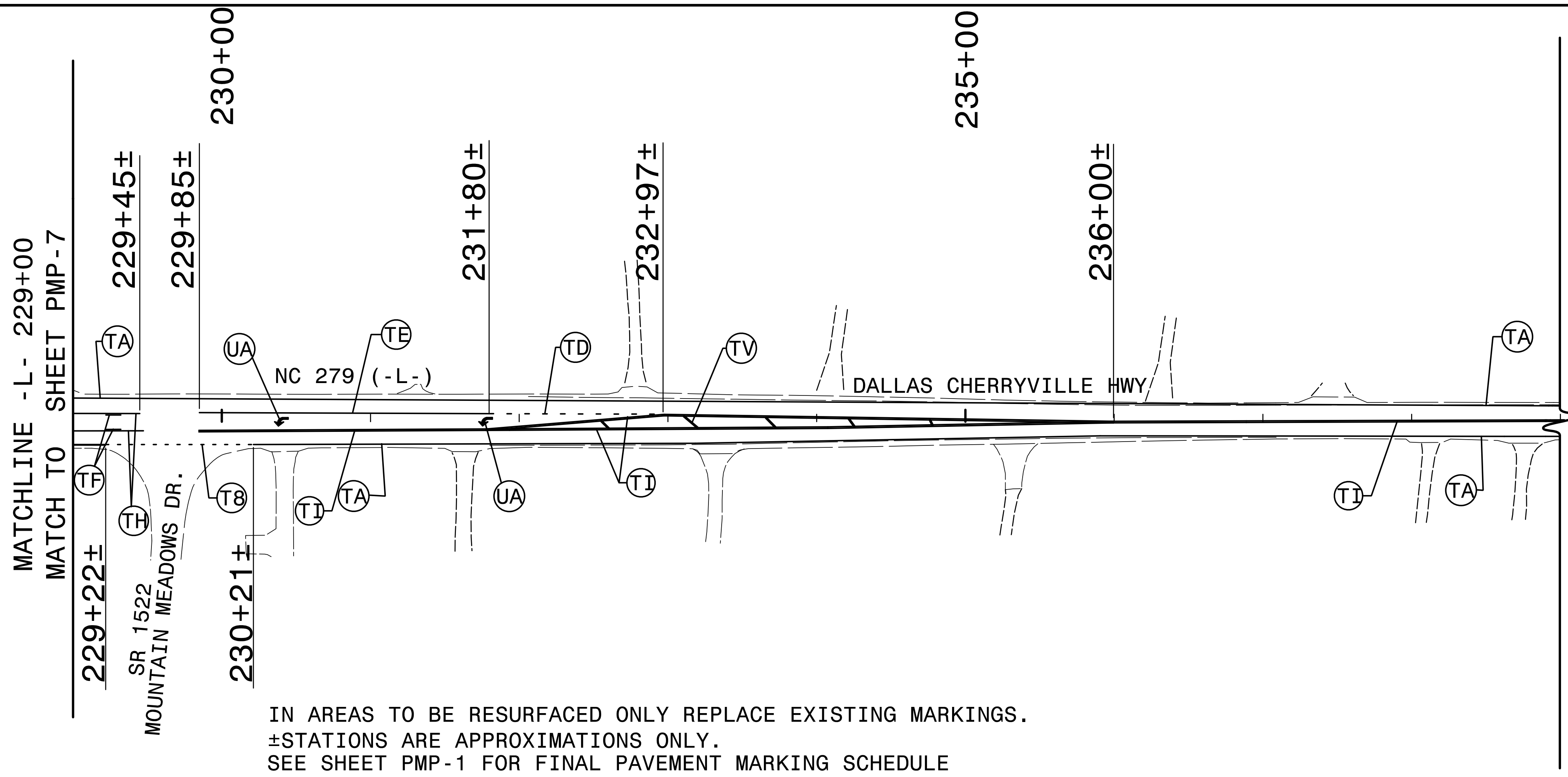

IN AREAS TO BE RESURFACED ONLY REPLACE EXISTING MARKINGS.
 ±STATIONS ARE APPROXIMATIONS ONLY.
 SEE SHEET PMP-1 FOR FINAL PAVEMENT MARKING SCHEDULE

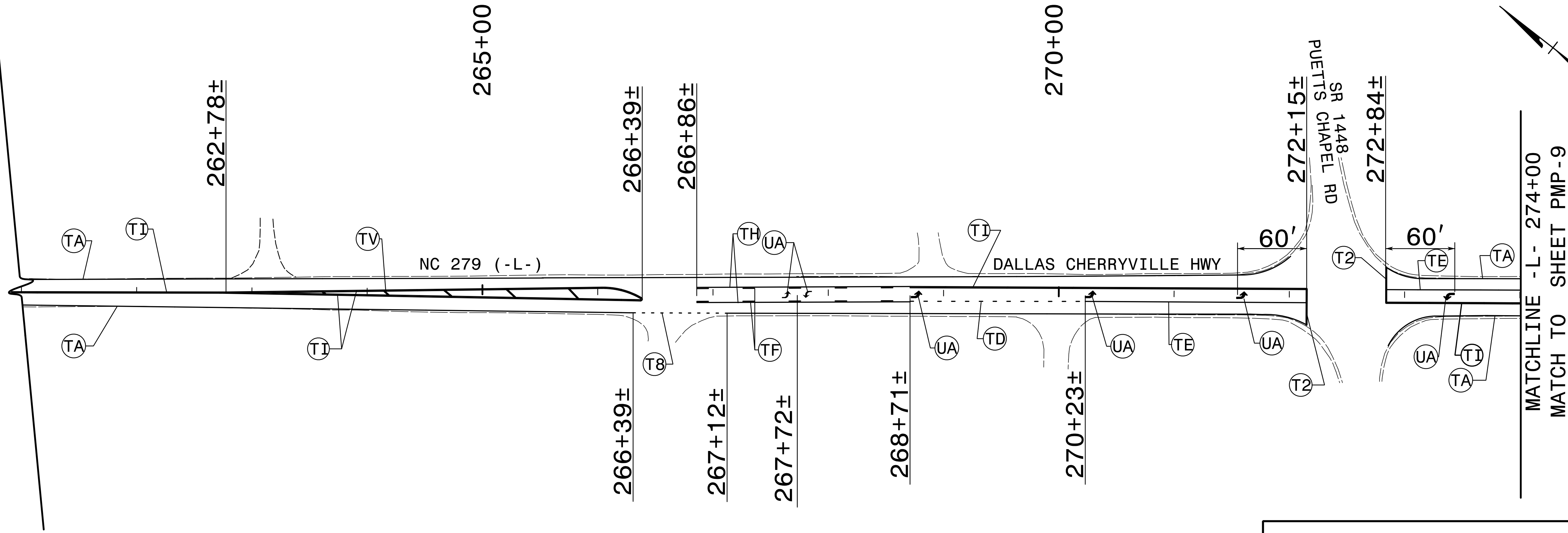

IN AREAS TO BE RESURFACED ONLY REPLACE EXISTING MARKINGS.
 ±STATIONS ARE APPROXIMATIONS ONLY.
 SEE SHEET PMP-1 FOR FINAL PAVEMENT MARKING SCHEDULE

FINAL PAVEMENT MARKING PLAN

9/11/2018
 X:\NGD001\W-5212N\Traffic\ Pavement Markings\W-5212N_Sgn_PMP_08.dgn
 User:ismel\in

TIP NO.	SHEET NO.
W-5212N	PMP-9
APPROVED: _____	
DATE: _____	
SEAL	
<p>DOCUMENT NOT CONSIDERED FINAL UNLESS ALL SIGNATURES COMPLETED</p>	
<p>TGS ENGINEERS 804-C N. LAFAYETTE ST SHELBY, NC 28150 PH (704) 476-0003 CORP. LICENSE NO.: C-0275</p>	

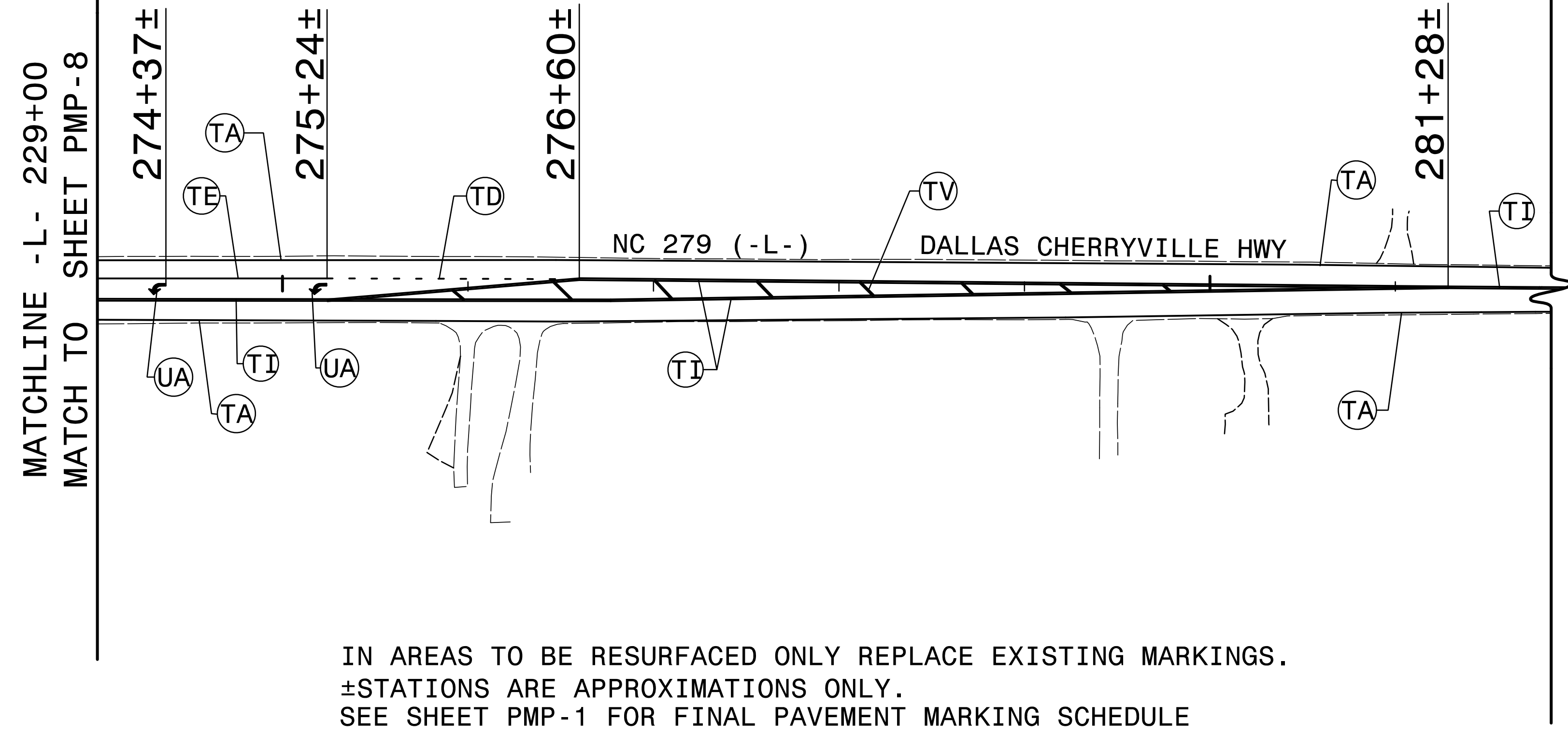

IN AREAS TO BE RESURFACED ONLY REPLACE EXISTING MARKINGS.
±STATIONS ARE APPROXIMATIONS ONLY.
SEE SHEET PMP-1 FOR FINAL PAVEMENT MARKING SCHEDULE

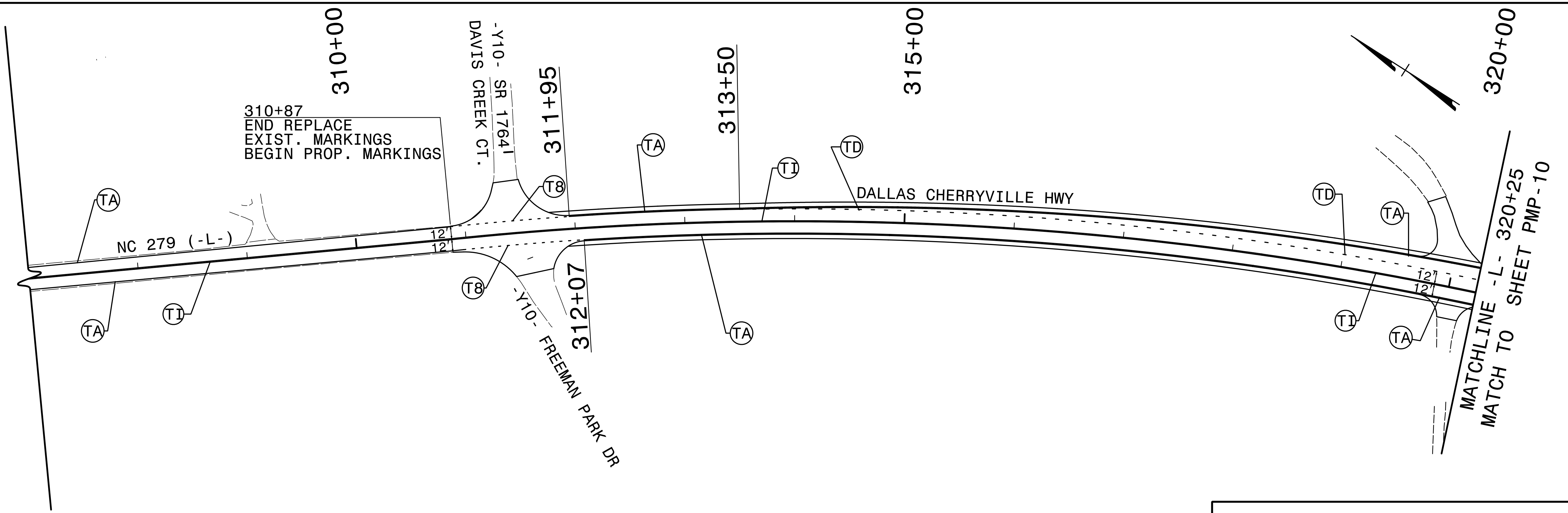

SEE SHEET PMP-1 FOR FINAL PAVEMENT MARKING SCHEDULE

FINAL PAVEMENT MARKING PLAN

9/11/2018
 X:\NGD001\W-5212N\Traffic\ Pavement Markings\W-5212N_Sgn_PMP_09.dgn
 User:ismel\m

TIP NO.	SHEET NO.
W-5212N	PMP-10
APPROVED: _____	
DATE: _____	
SEAL	
DOCUMENT NOT CONSIDERED FINAL UNLESS ALL SIGNATURES COMPLETED	
TGS ENGINEERS 804-C N. LAFAYETTE ST SHELBY, NC 28150 PH (704) 476-0003 CORP. LICENSE NO.: C-0275	

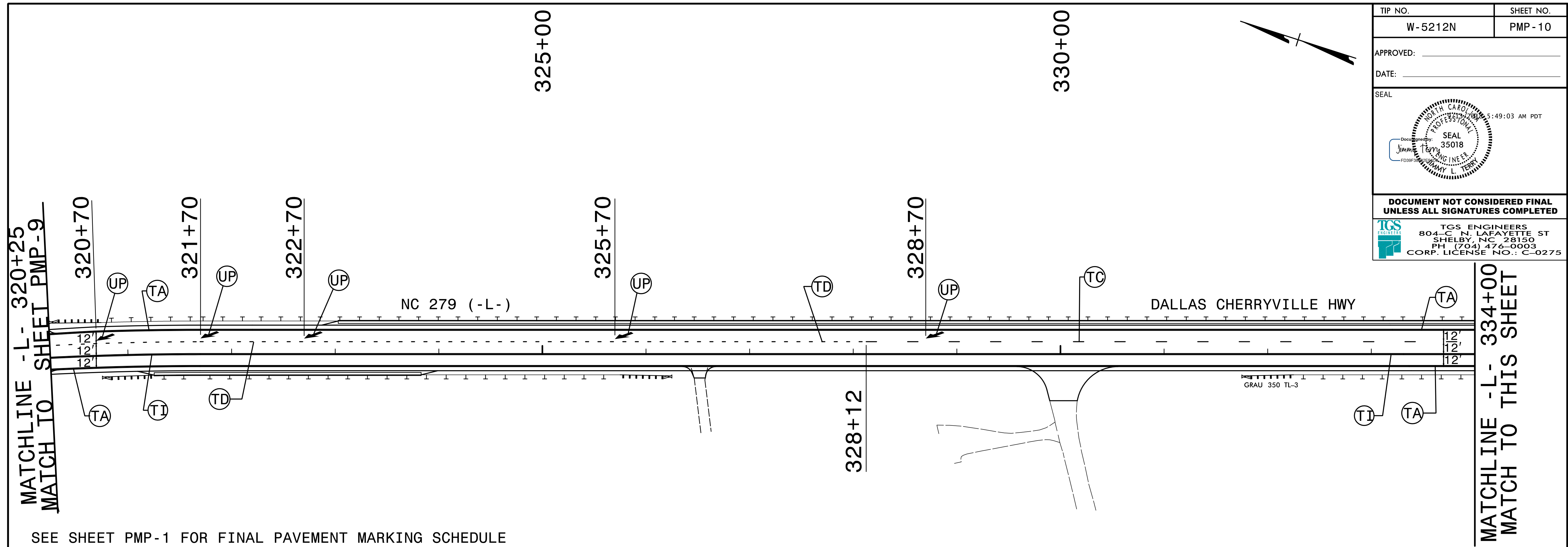

SEE SHEET PMP-1 FOR FINAL PAVEMENT MARKING SCHEDULE

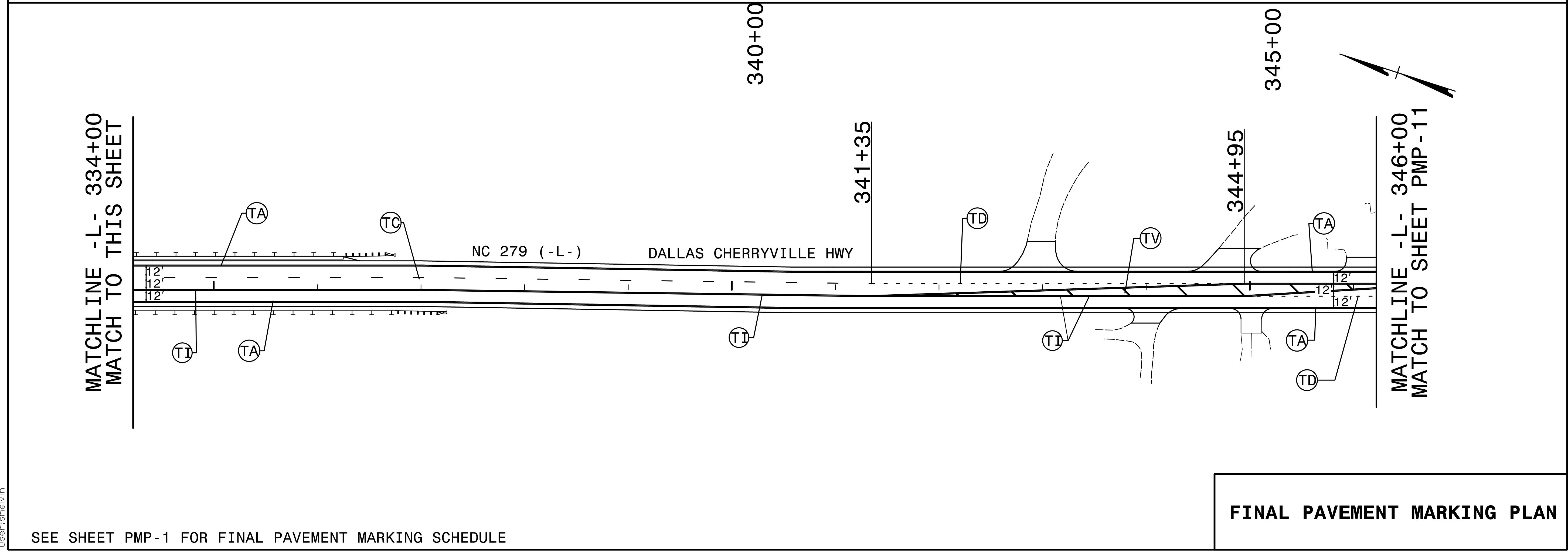

SEE SHEET PMP-1 FOR FINAL PAVEMENT MARKING SCHEDULE

FINAL PAVEMENT MARKING PLAN

9/11/2018 X:\NGD001\W-5212N\Traffic\Pavement Markings\W-5212N_Sgn_PMP_10.dgn User:smelvin

TIP NO.	SHEET NO.
W-5212N	PMP-11
APPROVED: _____	
DATE: _____	
SEAL	
DOCUMENT NOT CONSIDERED FINAL UNLESS ALL SIGNATURES COMPLETED	
TGS ENGINEERS 804-C N. LAFAYETTE ST SHELBY, NC 28150 PH (704) 476-0003 CORP. LICENSE NO.: C-0275	

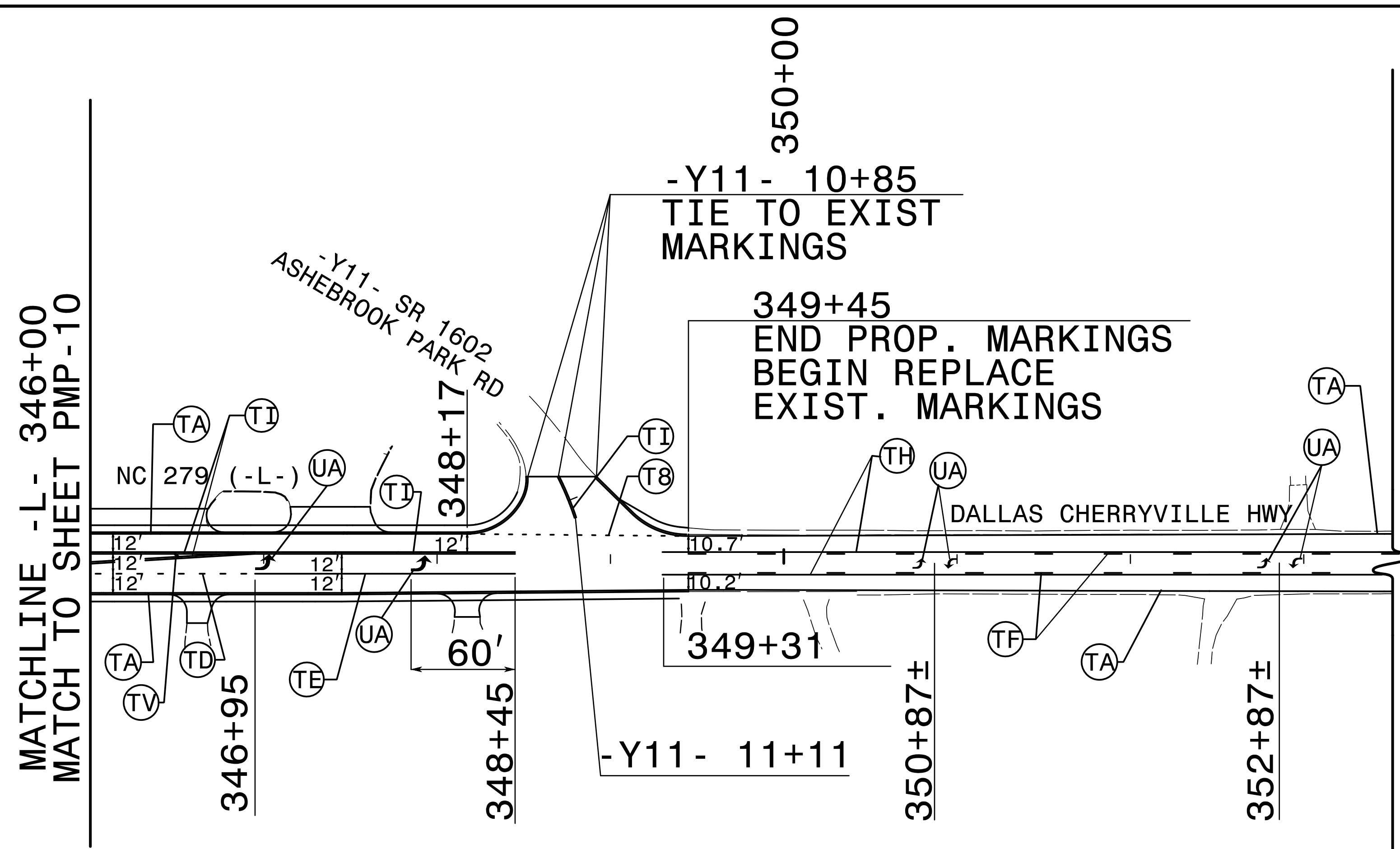

SEE SHEET PMP-1 FOR FINAL PAVEMENT MARKING SCHEDULE

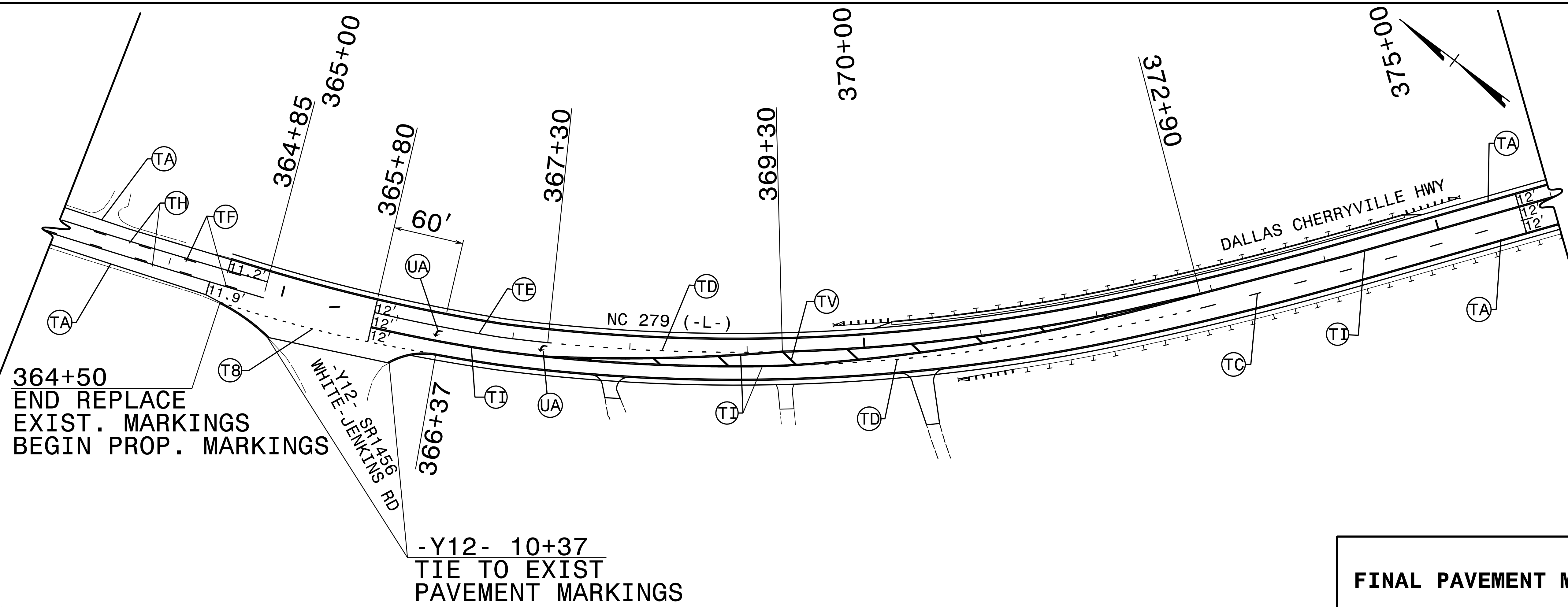

SEE SHEET PMP-1 FOR FINAL PAVEMENT MARKING SCHEDULE

FINAL PAVEMENT MARKING PLAN

9/11/2018 X:\NGD001\W-5212N\Traffic\ Pavement Markings\W-5212N_Sgn_PMP-11.dgn User:ismel\m

TIP NO.	SHEET NO.
W-5212N	PMP-12
APPROVED: _____	
DATE: _____	
SEAL	
DOCUMENT NOT CONSIDERED FINAL UNLESS ALL SIGNATURES COMPLETED	
TGS ENGINEERS 804-C N. LAFAYETTE ST SHELBY, NC 28150 PH (704) 476-0003 CORP. LICENSE NO.: C-0275	

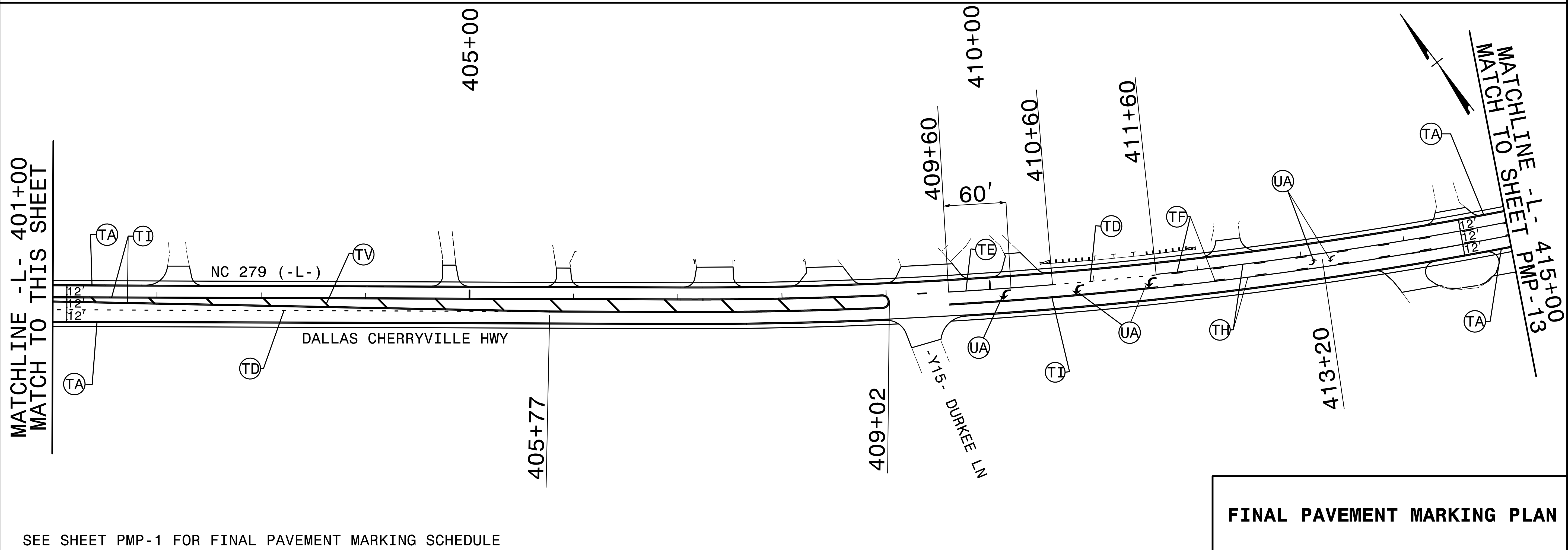
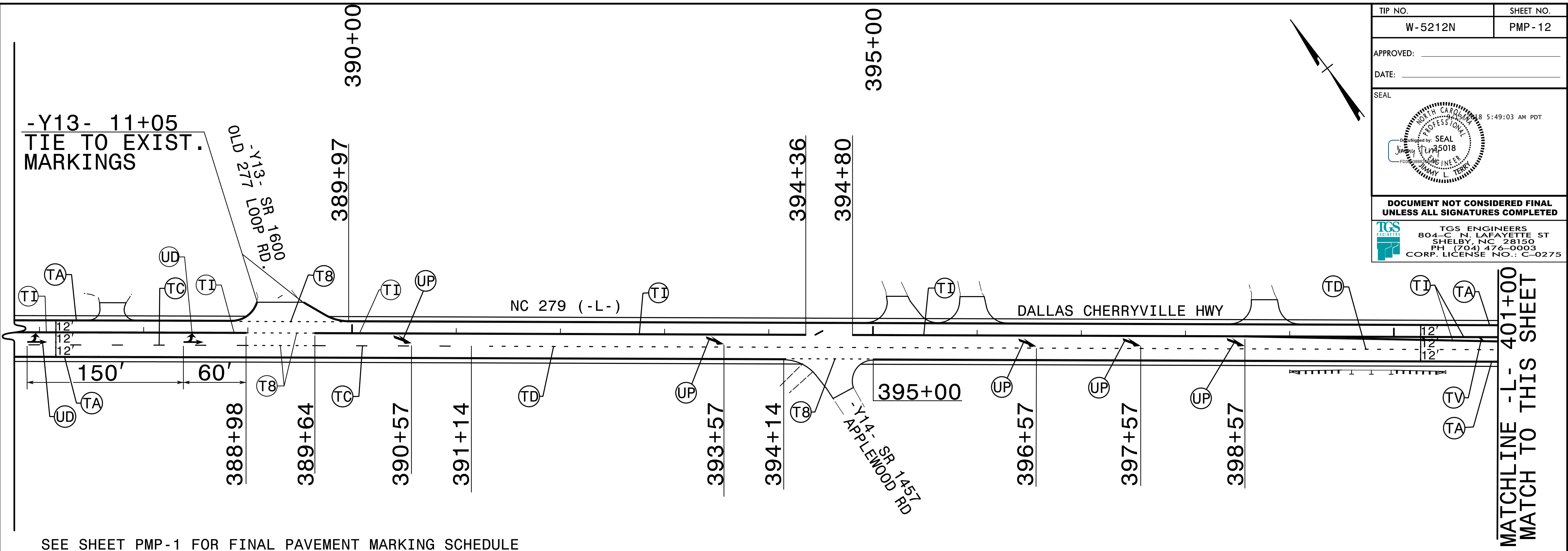

FINAL PAVEMENT MARKING PLAN

9/11/2018
 X:\NGDOT\W-5212N\Traffic\ Pavement Markings\W-5212N_Sgn_PMP_12.dgn
 User:smelvin

TIP NO.	SHEET NO.
W-5212N	PMP-13
APPROVED: _____	
DATE: _____	
SEAL	
DOCUMENT NOT CONSIDERED FINAL UNLESS ALL SIGNATURES COMPLETED	
TGS ENGINEERS 804-C N. LAFAYETTE ST SHELBY, NC 28150 PH: (704) 476-0003 CORP. LICENSE NO.: C-0275	

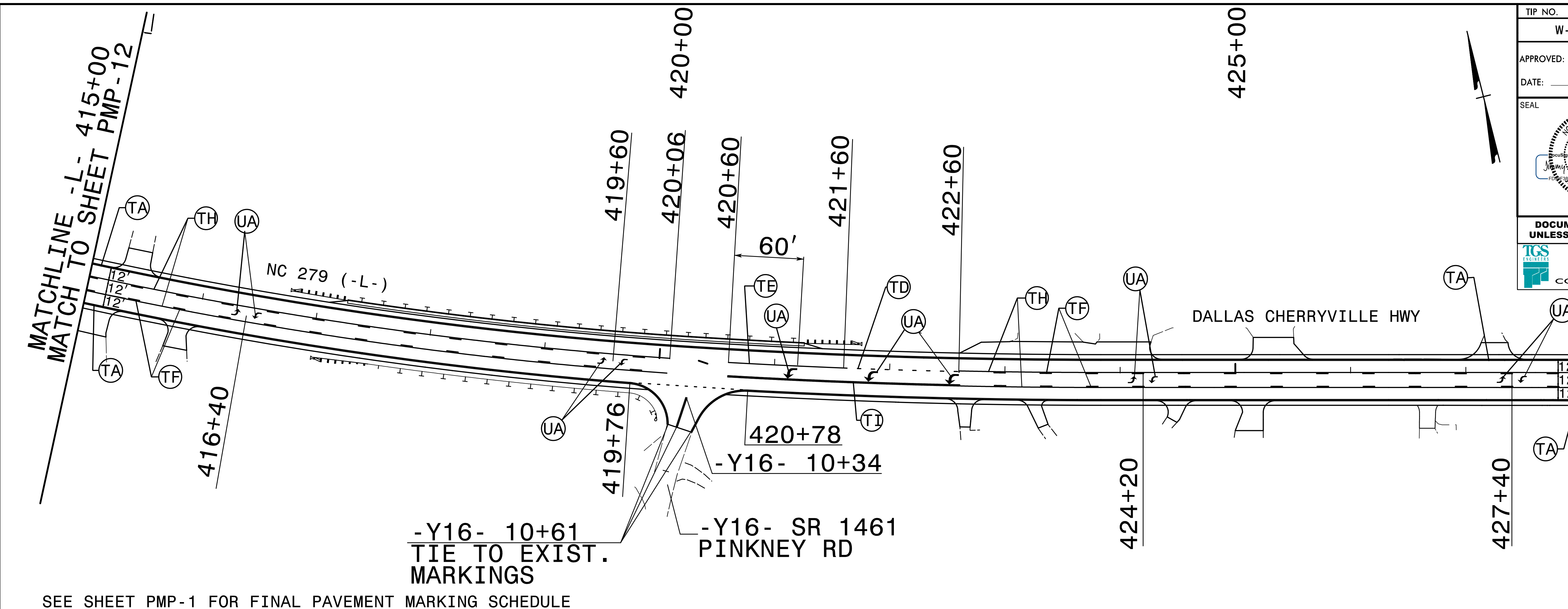

SEE SHEET PMP-1 FOR FINAL PAVEMENT MARKING SCHEDULE

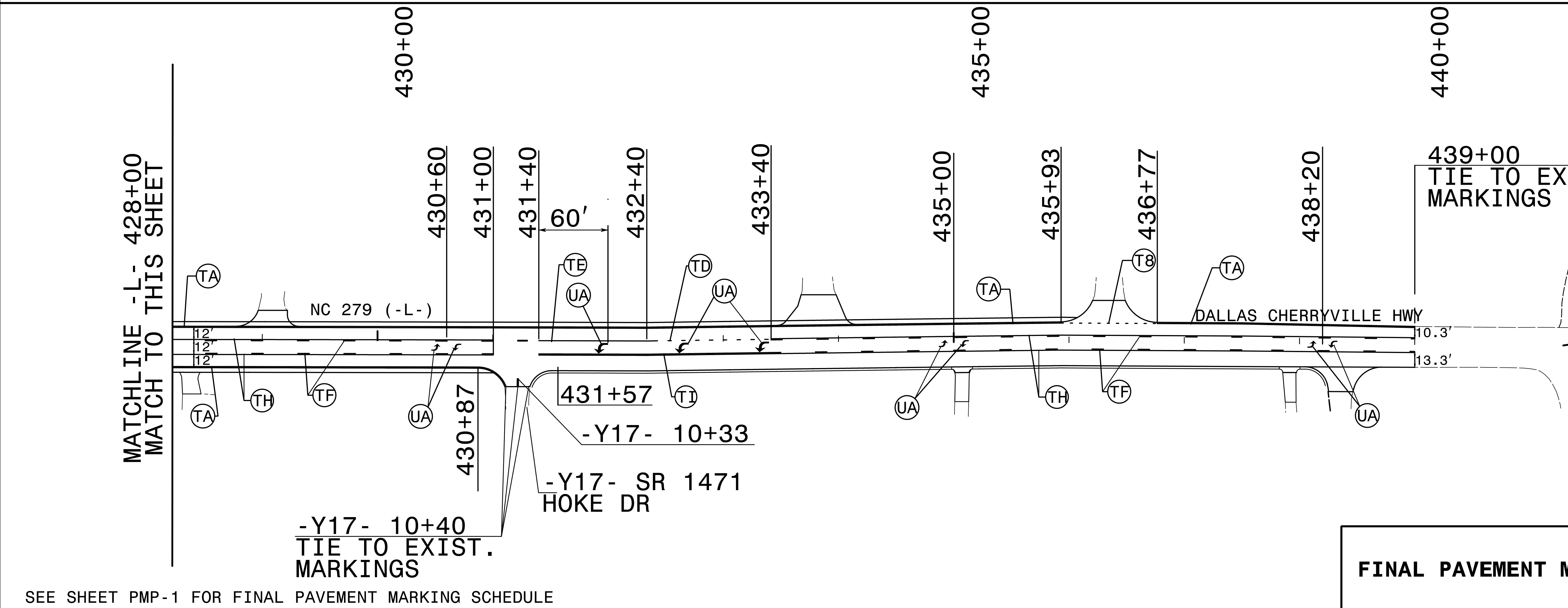

SEE SHEET PMP-1 FOR FINAL PAVEMENT MARKING SCHEDULE

FINAL PAVEMENT MARKING PLAN

9/11/2018
X:\NGDOT\W-5212N\Traffic\ Pavement Markings\W-5212N_Sgn_PMP_13.dgn
User:smelvin