

REVISIONS

-DETI-			
PI Sta 10+34.53 Δ = 6' 02" 08.9" (RT) D = 8' 44" 52.6" L = 69.00' T = 34.53' R = 654.96'	PI Sta 11+45.77 Δ = 34' 08" 29.4" (LT) D = 22' 55" 05.9" L = 148.97' T = 76.77' R = 250.00'	PI Sta 15+08.36 Δ = 90' 04" 41.4" (RT) D = 19' 45" 25.8" L = 455.93' T = 290.40' R = 290.00'	PI Sta 17+48.47 Δ = 33' 13" 13.8" (LT) D = 22' 55" 05.9" L = 144.95' T = 74.58' R = 250.00'

-DETIA-
PI Sta 11+54.97 Δ = 5' 32" 38.4" (RT) D = 15' 26" 37.0" L = 35.90' T = 17.96' R = 371.00'

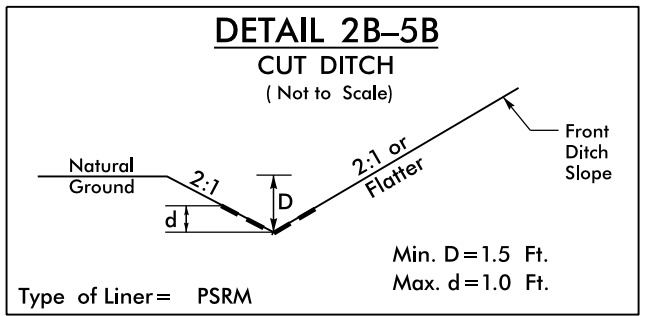
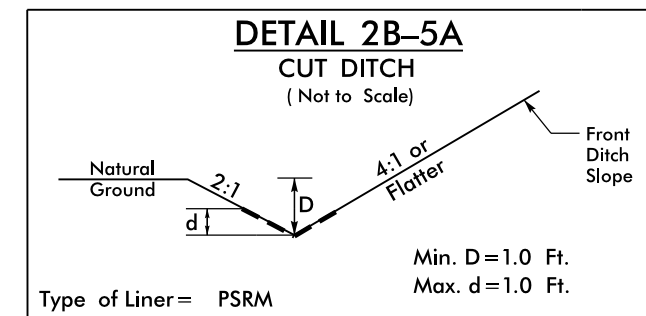

FROM -DETIA- STA. 10+00 RT TO -DETIA- STA. 11+35 RT
FROM DETI STA 17+29 TO 18+00 LT
FROM DETI STA 13+50 TO 13+80 LT

7/13/2018 10:05:26 AM
H:\Projects\2018\U-5604-Hyd.ec-psh13.cad

8/17/19