

CLEARING AND GRUBBING
EROSION CONTROL FOR
CONSTRUCTION SHEET 2B-5

NOTE:
PLACE TEMPORARY ROCK SEDIMENT DAMS TYPE - B
AND TEMPORARY ROCK SILT CHECKS TYPE - A AT
DRAINAGE OUTLETS.

-DETI-			
PI Sta 10+34.53 Δ = 6' 02" 08.9" (RT) D = 8' 44" 52.6" L = 69.00' T = 34.53' R = 654.96'	PI Sta 11+45.77 Δ = 34' 08" 29.4" (LT) D = 22' 55" 05.9" L = 148.97' T = 76.77' R = 250.00'	PI Sta 15+08.36 Δ = 90' 04" 41.4" (RT) D = 19' 45" 25.8" L = 455.93' T = 290.40' R = 290.00'	PI Sta 17+48.47 Δ = 33' 13" 13.8" (LT) D = 22' 55" 05.9" L = 144.95' T = 74.58' R = 250.00'

-DETI-
PI Sta 11+54.97 Δ = 5' 32" 38.4" (RT) D = 15' 26" 37.0" L = 35.90' T = 17.96' R = 371.00'

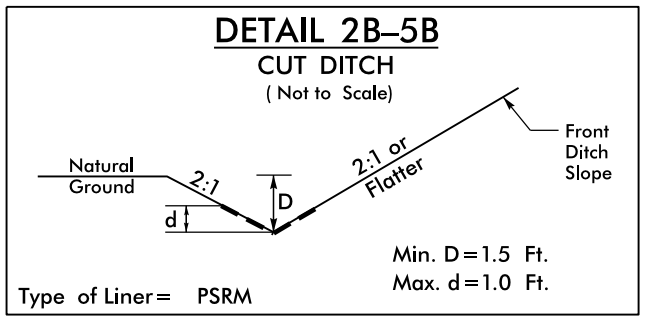
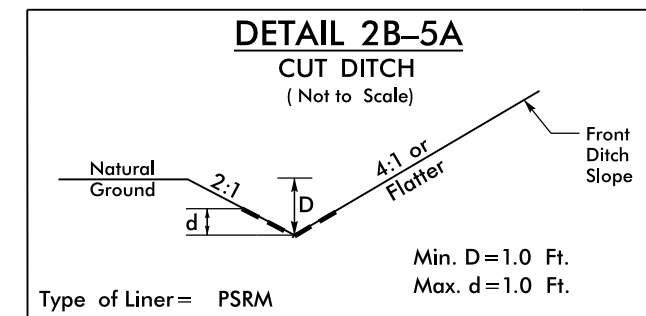

FROM -DETI- STA. 10+00 RT TO -DETI- STA. 11+35 RT
FROM DETI STA 17+29 TO 18+00 LT
FROM DETI STA 13+50 TO 13+80 LT

REVISIONS

7/13/2018 10:02:37 AM
I:\Projects\2018\U-5604_Hyd.ec.psh\10.dgn
8/17/19

38
NO CLAIM
MICHAEL T HOUSTON
DB V 36
PG 107

JOSHUA FOUTS
DB S 31
PG 1700

MIKOL OCHSNER
INC
DB O 24
PG 1984

WOMACK, WILLIAM
TERRY
DB M 36
PG 2171

37
K&H ENTERPRISES LLC
DB J 30
PG 2304

HURSEY ENTERPRISES LLC
DB U 34
PG 275

SPRINGS BARIUM
DB Z 34
PG 516

5
MICHAEL B GREGORY
DB E 33
PG 2248

6
WOMACK, WILLIAM
TERRY
DB M 36
PG 2171

7
TOMMY V MCCOY
DB W 19
PG 2384

3
DONALD WOODY FISHER
DB V 37
PG 1077

2
JOHN L CRAWFORD
DB P 6
PG 188

1
AR HIGDON
DB IA
PG 1997

4
NO CLAIM
LONG, REBECCA DYER
DB 21
PG 2233

BEGIN CONSTRUCTION
-DETI- POC STA. 10+00.00

BEGIN CONSTRUCTION
-DETI- POT STA. 10+00.00

END CONSTRUCTION
-DETI- POT STA. 18+18.85

-DETI- POT Sta. 10+00.00
AHD BRG S 65° 24' 46.9" E

-DETI- PC Sta. 11+37.00
AHD BRG S 59° 52' 08.5" E

-DETI- PT Sta. 11+72.90

-DETI- Sta. 14+19.03 =
-DETI- Sta. 11+84.99

30 x 15 x 3
ID 2B-5.1

-DETI- PRC Sta. 16+73.89

-DETI- PT Sta. 18+18.85

SP CUT DITCH
SEE DETAIL 2B-5B
OUTLET PROTECTION
1-TONS CL-B RIPRAP
5 SY GEOTEXT-FABRIC

15' STUB POLE
WITH ELECTRIC
SERVICE LINE
BOX AND METER

SP. CUT DITCH
SEE DETAIL 2B-5A

OUTLET PROTECTION
1-TONS CL-B RIPRAP
5 SY GEOTEXT-FABRIC

SP. CUT DITCH
SEE DETAIL 2B-5B

-DETI- PC Sta. 10+00.00

-DETI- PRC Sta. 10+69.00

-DETI- PRC Sta. 12+60.00

-DETI- PT Sta. 11+72.90

-DETI- Sta. 14+19.03 =
-DETI- Sta. 11+84.99

-DETI- PRC Sta. 16+73.89

-DETI- PT Sta. 18+18.85

-DETI- POT STA. 18+18.85

-DETI- POT STA. 10+00.00

-DETI- POC STA. 10+00.00

-DETI- POT STA. 10+00.00

-DETI- POT STA. 10+00.00

-DETI- POT STA. 10+00.00

-DETI- POT STA. 10+00.00

-DETI- POT STA. 10+00.00

-DETI- POT STA. 10+00.00

-DETI- POT STA. 10+00.00

-DETI- POT STA. 10+00.00

-DETI- POT STA. 10+00.00

-DETI- POT STA. 10+00.00

-DETI- POT STA. 10+00.00

-DETI- POT STA. 10+00.00

-DETI- POT STA. 10+00.00

-DETI- POT STA. 10+00.00

-DETI- POT STA. 10+00.00

-DETI- POT STA. 10+00.00

-DETI- POT STA. 10+00.00

-DETI- POT STA. 10+00.00

-DETI- POT STA. 10+00.00

-DETI- POT STA. 10+00.00

-DETI- POT STA. 10+00.00