

CONFIDENTIAL AND PROPRIETARY PROPERTY OF  
**EBDG - NC, PLLC**  
 MAY NOT BE USED FOR CONSTRUCTION OR PROVIDED TO  
 ANY THIRD PARTIES WITHOUT PRIOR WRITTEN CONSENT.  
 ©2018 ELLIOTT BAY DESIGN GROUP.

REVISION HISTORY					
REV	ZONE	DESCRIPTION	DWN	DATE	APVD
A	1-1A	1. CORRECTED DRAWING TITLE	SKW	8/6/18	SKW

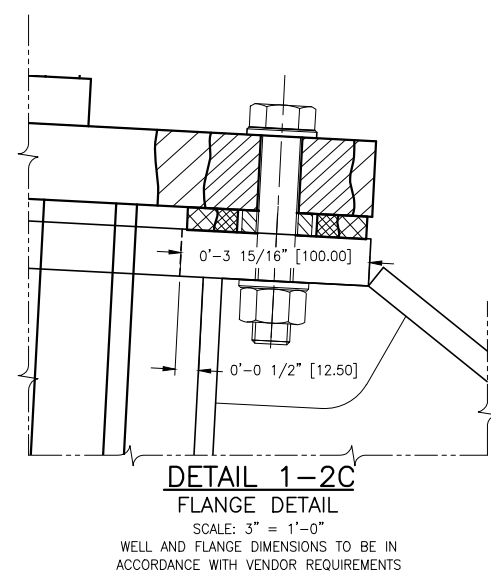
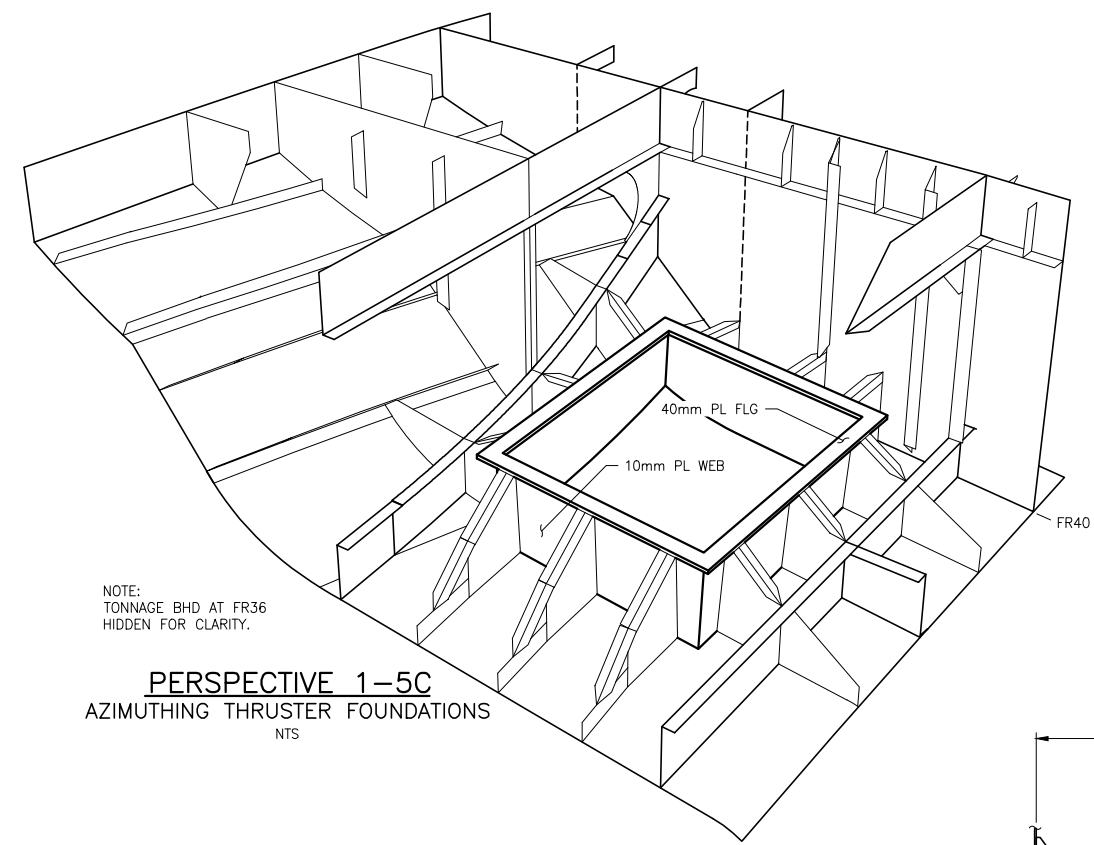

- GENERAL NOTES**
1. VESSEL TO BE CONSTRUCTED IN ACCORDANCE WITH 46 CFR SUBCHAPTER H REGULATIONS.
  2. FRAME SPACING IS 24" UNLESS NOTED OTHERWISE.
  3. PROPULSION UNIT FOUNDATION CONNECTION DETAILS SHALL BE MADE TO MANUFACTURER'S SATISFACTION.
  4. BRACKETS SUPPORTING PROPULSION UNIT FLANGE SHALL BE DESIGNED TO ALLOW PROPER ACCESS TO BOLTS.
  5. THESE FOUNDATIONS ARE PROVIDED FOR GUIDANCE ONLY. FINAL FOUNDATION DESIGN SHALL BE PERFORMED BY THE CONTRACTOR AND REVIEWED BY THE OWNER AND EQUIPMENT MANUFACTURERS.

- REFERENCES**
1. 18026-200-832-1 TECHNICAL SPECIFICATION
  2. 18026-200-061-1 SCANTLING CALCULATIONS
  3. 18026-200-100-1 LINES PLAN
  4. 18026-200-101-1 PROFILES AND DECK ARRANGEMENTS
  5. 18026-200-110-1 BOTTOM AND SIDE SHELL
  6. 18026-200-120-3 HULL TRANSVERSE BULKHEADS
  7. 18026-200-120-4 HULL TRANSVERSE FRAMES
  8. 18026-200-120-5 HULL LONGITUDINAL BULKHEADS AND GIRDERS
  9. EINBAUZEICHNUNG FER-180069-01 SCHOTTEL

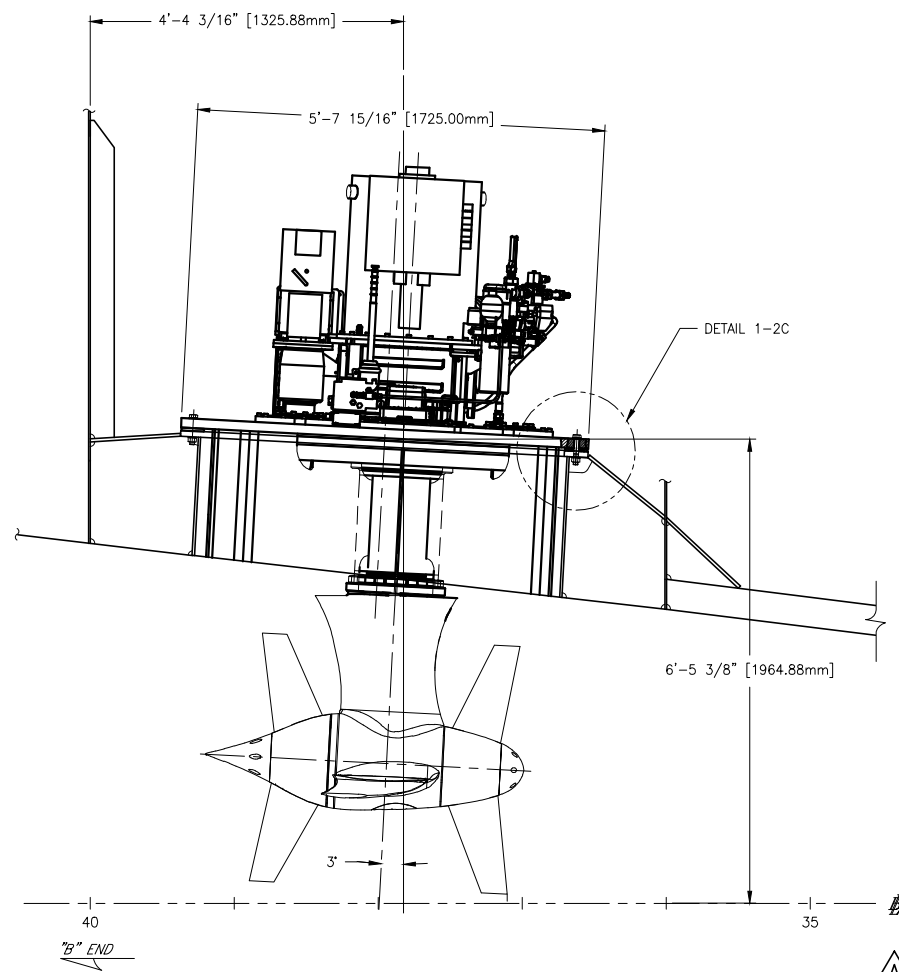
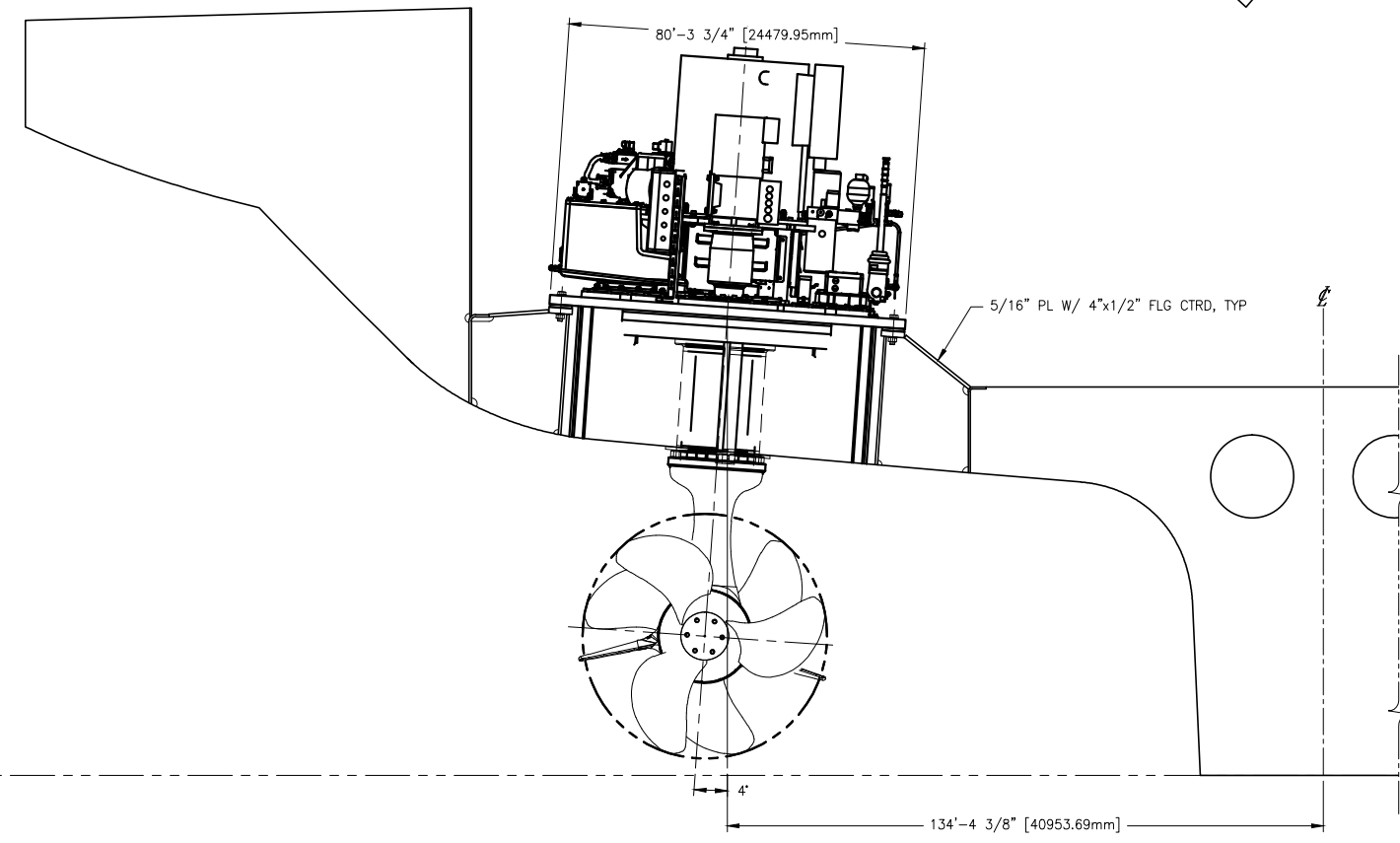

**Elliott Bay Design Group**  
 North Carolina, PLLC

CLIENT: NORTH CAROLINA D.O.T.  
 RALEIGH, NORTH CAROLINA  
 PROJECT: DOUBLE-ENDED AZIMUTH DRIVE FERRY

TITLE: MAIN MACHINERY FOUNDATIONS

SIZE	DWG NO.	18026-200-180-1	REV	A
SCALE	AS NOTED	FILE NAME	18026-200-180-1A	SHEET 1 OF 2
DWN	JCG	MOD	SKW	CD SKW
APVD	SKW	APVD DATE	7/26/2018	



8/6/2018 11:09:30 AM

CONFIDENTIAL AND PROPRIETARY PROPERTY OF  
**EBDG - NC, PLLC**  
 MAY NOT BE USED FOR CONSTRUCTION OR PROVIDED TO  
 ANY THIRD PARTIES WITHOUT PRIOR WRITTEN CONSENT.  
 ©2018 ELLIOTT BAY DESIGN GROUP.

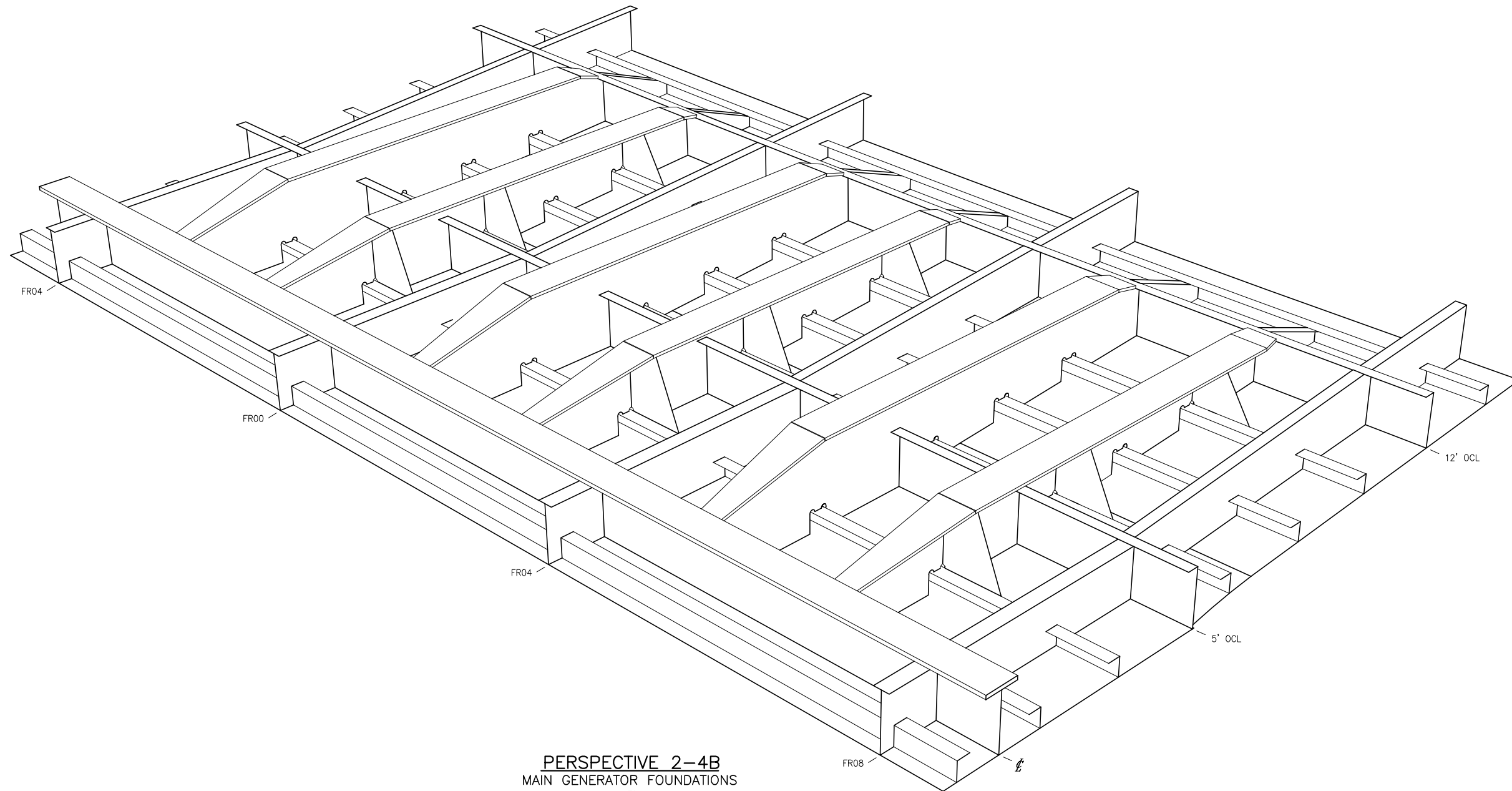

**PERSPECTIVE 2-4B**  
 MAIN GENERATOR FOUNDATIONS  
 NTS

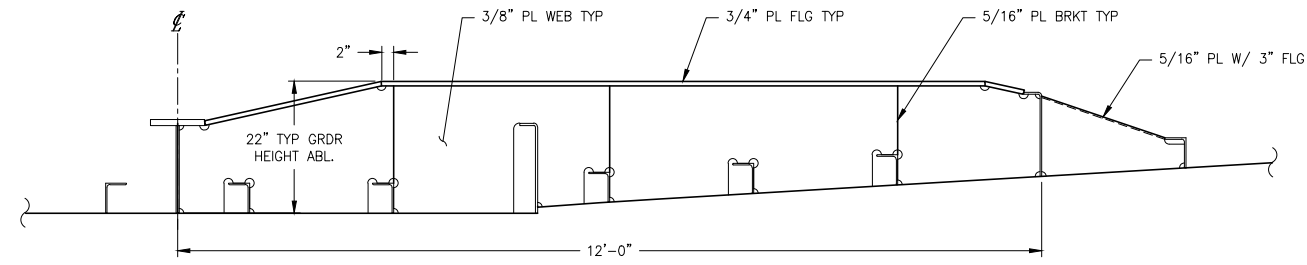

**SECTION 2-3A**  
 TYP MAIN GEN FDN  
 LOOKING TO B-END  
 SCALE: 3/4" = 1'-0"



SIZE	D	DWG NO.	18026-200-180-1	REV	A
SCALE	AS NOTED	FILE NAME	18026-200-180-1A	SHEET	2 OF 2

8/6/2018 11:09:34 AM