

CONFIDENTIAL AND PROPRIETARY PROPERTY OF
EBDG - NC, PLLC
 MAY NOT BE USED FOR CONSTRUCTION OR PROVIDED TO
 ANY THIRD PARTIES WITHOUT PRIOR WRITTEN CONSENT.
 ©2018 ELLIOTT BAY DESIGN GROUP.

REVISION HISTORY					
REV	ZONE	DESCRIPTION	DWN	DATE	APVD
A	1-3C 1-5C	1. CHANGED EOS GRATING LEVEL TO 28"	SKW	8/2/18	SKW
B	1-2B	1. CORRECTED REFERENCED DRAWING TITLE	SKW	8/6/18	SKW

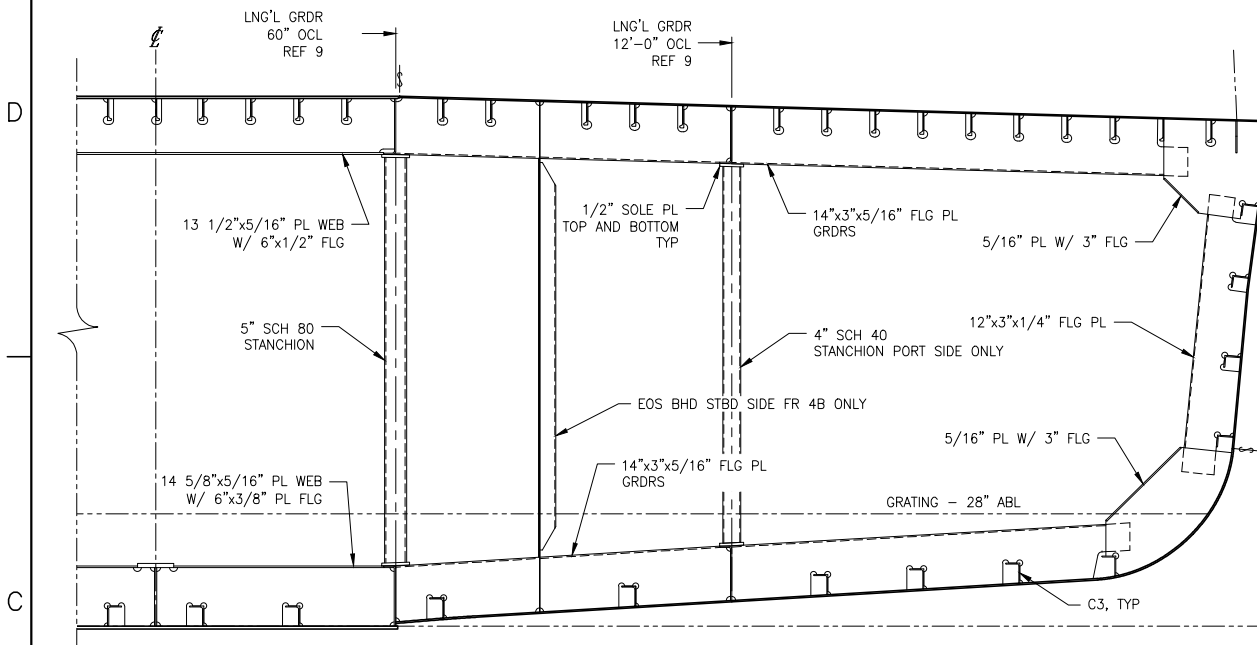

SECTION 1-5C
FRAME 04, 'B' END
 LOOKING FWD; STBD SIM/OPP
 FRAMES 4A, 8A, 12B SIM. U.N.O.

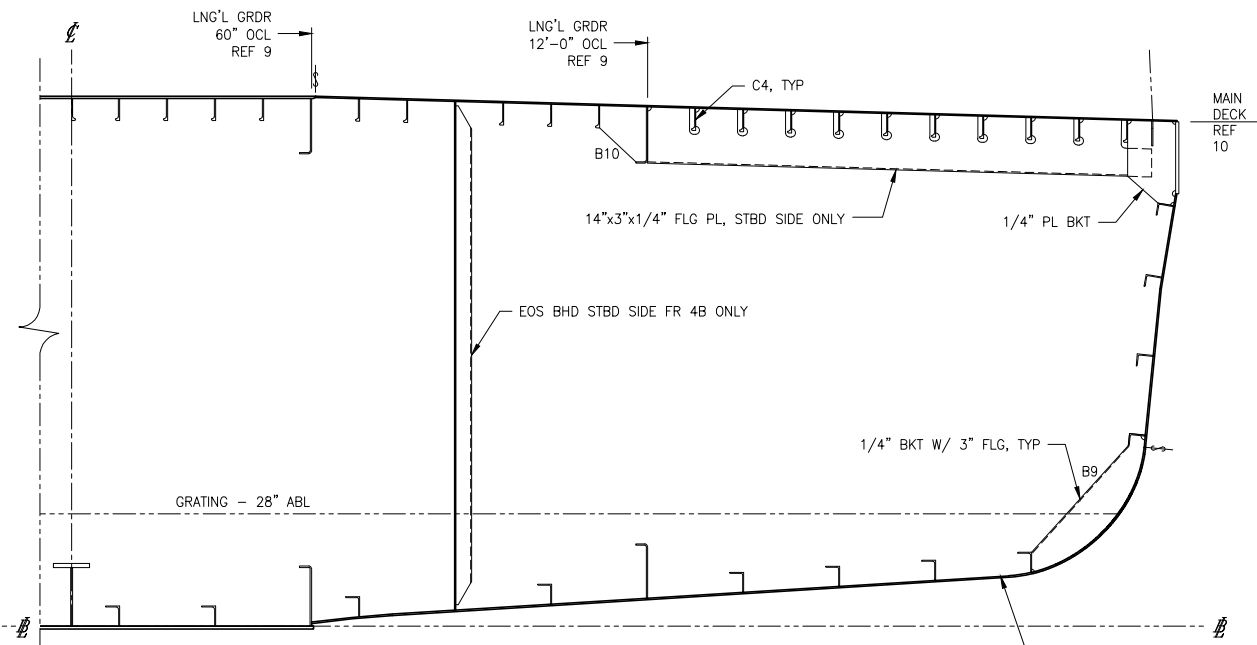

SECTION 1-3C
FRAME 06, 'B' END
 LOOKING FWD
 'A' END SIM/OPP, U.N.O.

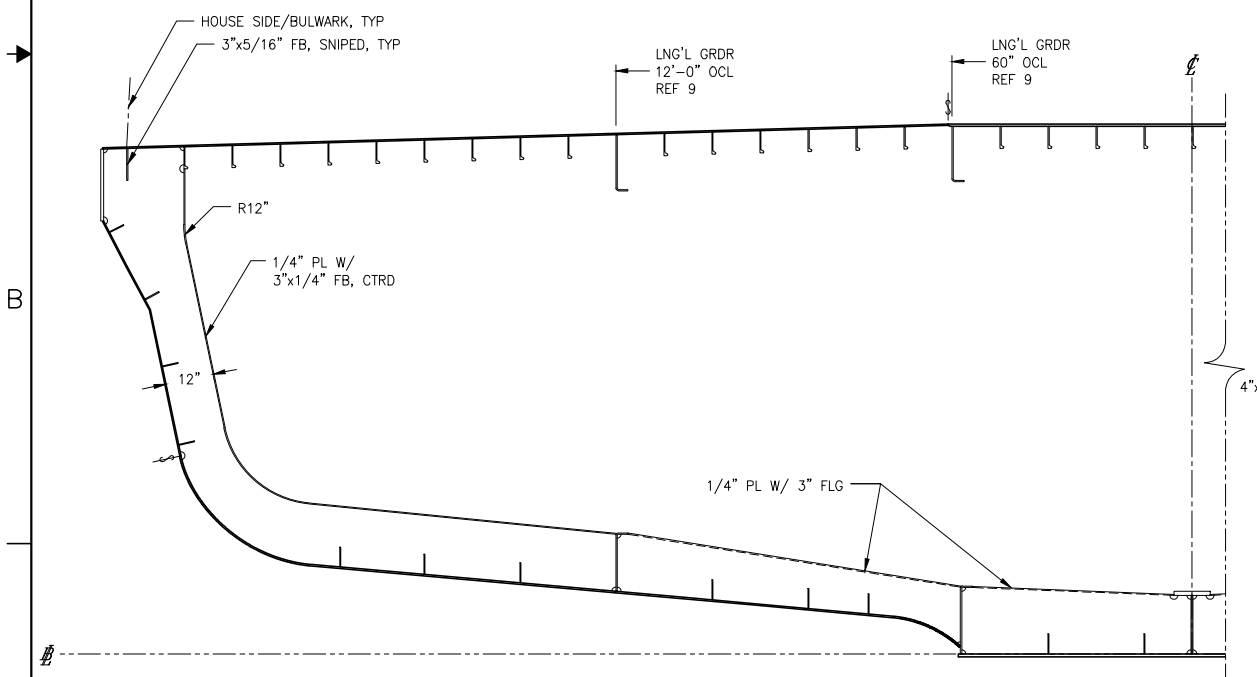

SECTION 1-5A
FRAME 18, 'B' END
 LOOKING FWD; STBD SIM/OPP
 FRAMES 22, 26, 30, SIM. U.N.O.
 'A' END SIM/OPP, INCLUDING 14A

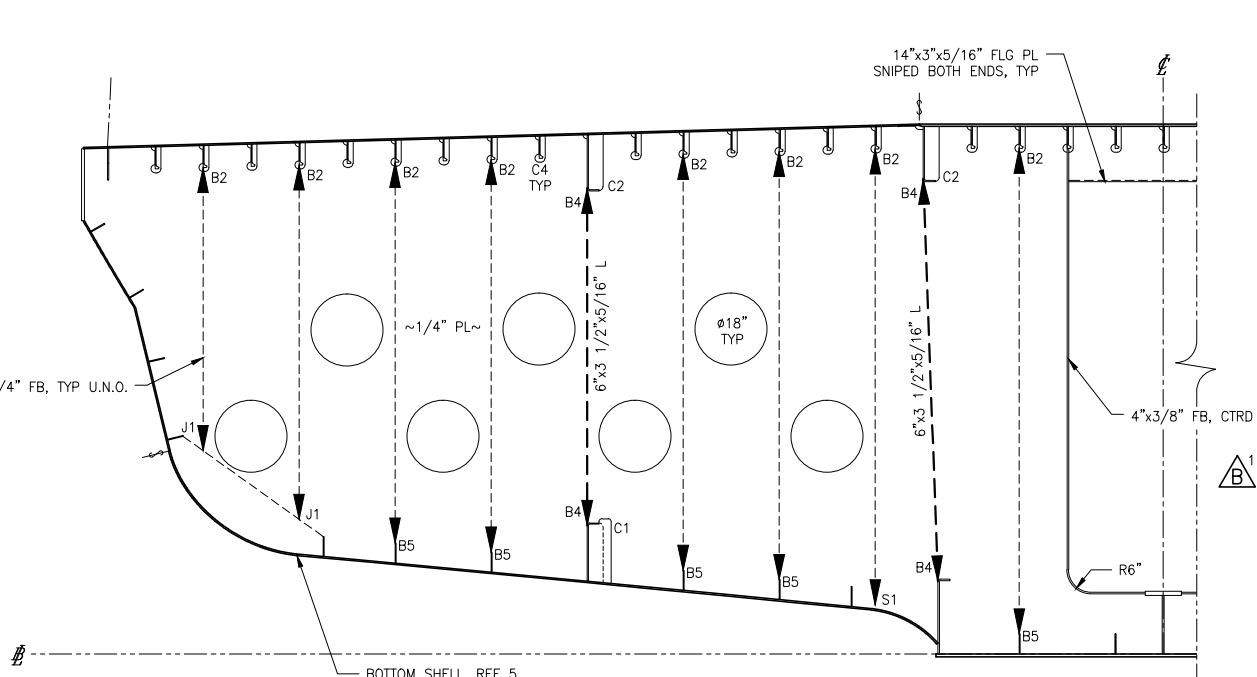

SECTION 1-3A
FRAME 20 'B' END
 LOOKING FWD; STBD SIM/OPP
 'A' END SIM/OPP, INCLUDING FR 12

KEY

	BULKHEAD FAR SIDE
	BULKHEAD NEAR SIDE
	GIRDER FAR SIDE
	GIRDER NEAR SIDE
	ORDINARY STIFFENER FAR SIDE
	ORDINARY STIFFENER NEAR SIDE
	KNUCKLE

GENERAL NOTES

- VESSEL TO BE CONSTRUCTED IN ACCORDANCE WITH 46 CFR SUBCHAPTER H REGULATIONS.
- FRAME SPACING IS 24" UNLESS NOTED OTHERWISE.

REFERENCES

- 18026-200-832-1 TECHNICAL SPECIFICATION
- 18026-200-061-1 SCANTLING CALCULATIONS
- 18026-200-100-1 LINES PLAN
- 18026-200-101-1 PROFILES AND DECK ARRANGEMENTS
- 18026-200-110-1 BOTTOM AND SIDE SHELL
- 18026-200-120-1 MIDSHIP SECTION
- 18026-200-120-3 HULL TRANSVERSE BULKHEADS
- 18026-200-120-4 HULL TRANSVERSE FRAMES
- 18026-200-120-5 HULL LONGITUDINAL BULKHEADS AND GIRDERS
- 18026-200-130-2 MAIN DECK
- 18026-200-180-1 MAIN MACHINERY FOUNDATIONS



Elliott Bay Design Group
 North Carolina, PLLC

CLIENT: NORTH CAROLINA D.O.T.
 RALEIGH, NORTH CAROLINA

PROJECT: DOUBLE-ENDED AZIMUTH DRIVE FERRY



HULL TRANSVERSE FRAMES

SIZE	D	DWG NO.	18026-200-120-4	REV	B
SCALE	1/2" = 1'-0"	FILE NAME	18026-200-120-4B	SHEET	1 OF 4
DWN	JCG	MOD	SKW	CD	SKW
APVD	SKW	APVD DATE	7/26/18		

8/6/2018 11:05:51 AM

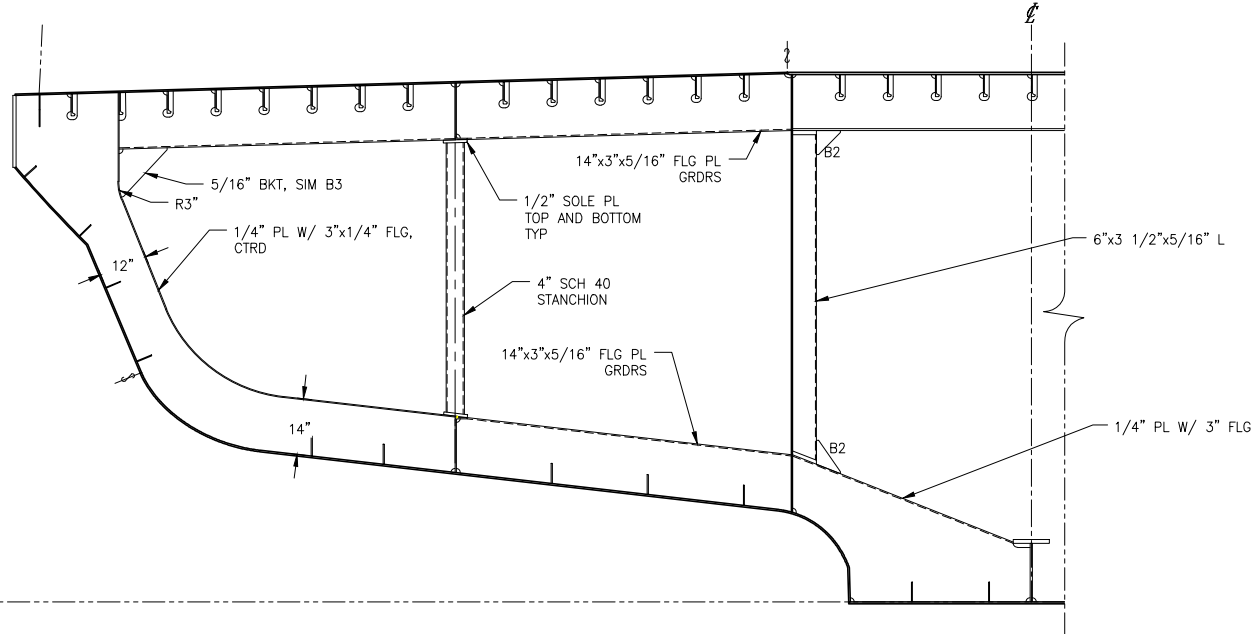

SECTION 2-5C
 FRAME 28, 'B' END
 LOOKING FWD: STBD SIM/OPP
 'A' END SIM/OPP

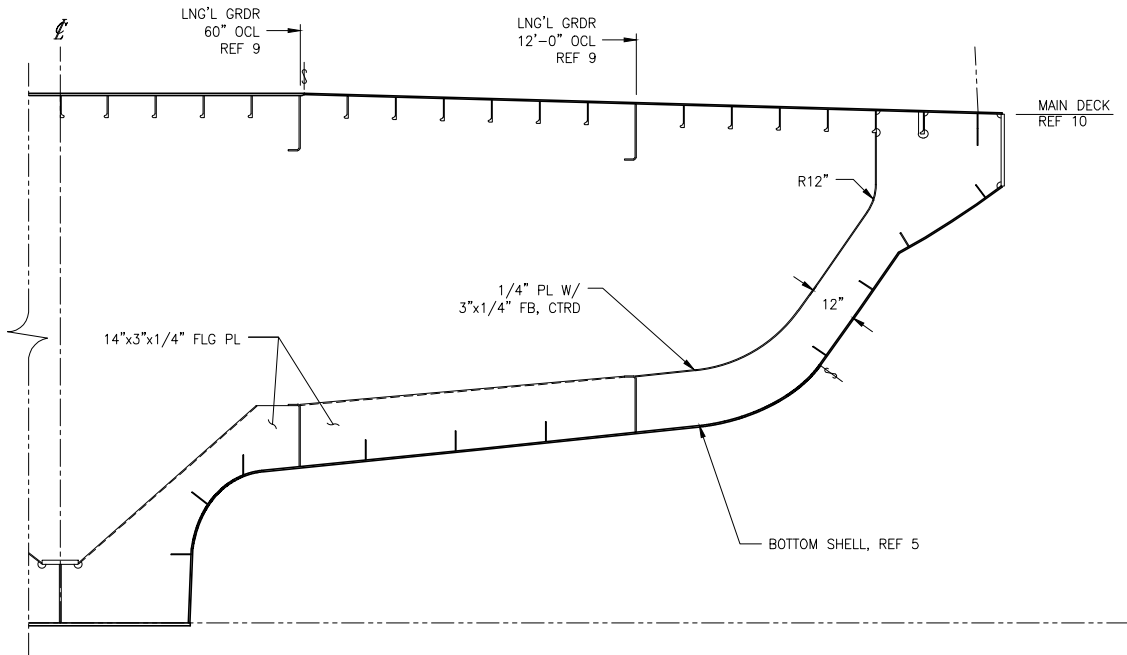

SECTION 2-2C
 FRAME 34, 'B' END
 LOOKING FWD
 'A' END SIM/OPP, U.N.O.

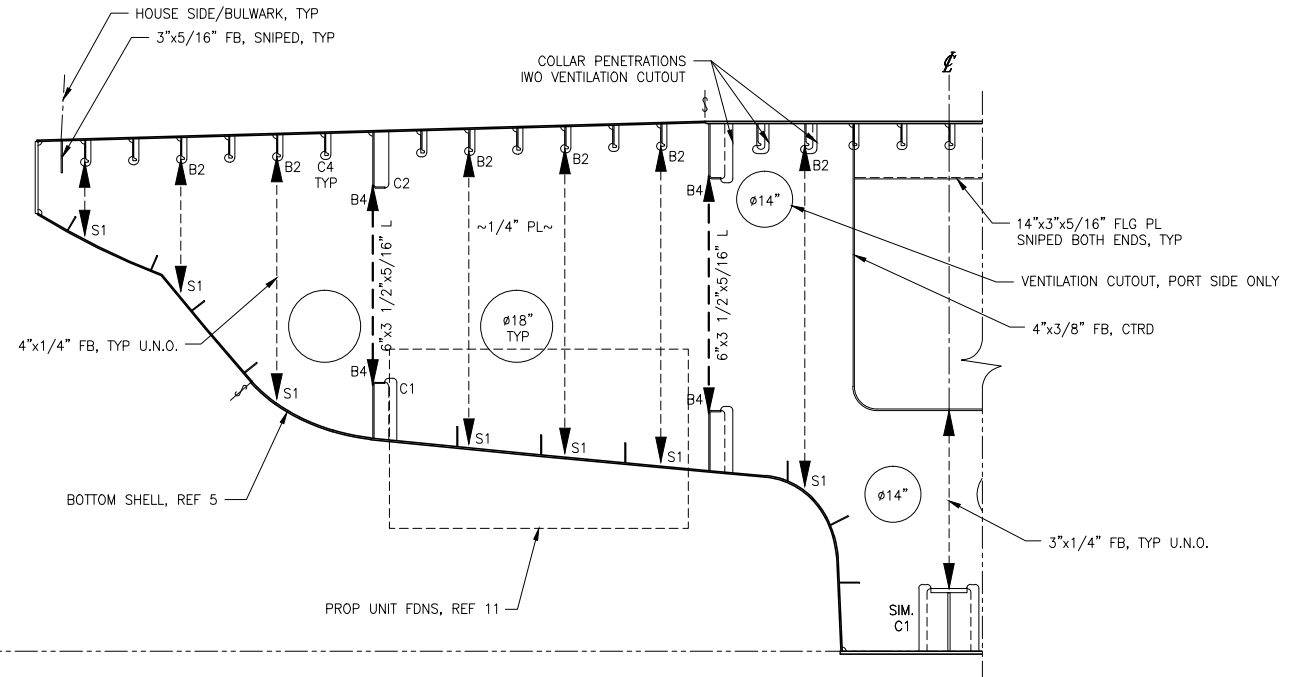

SECTION 2-5A
 FRAME 36, 'B' END
 LOOKING FWD: STBD SIM/OPP
 'A' END SIM/OPP

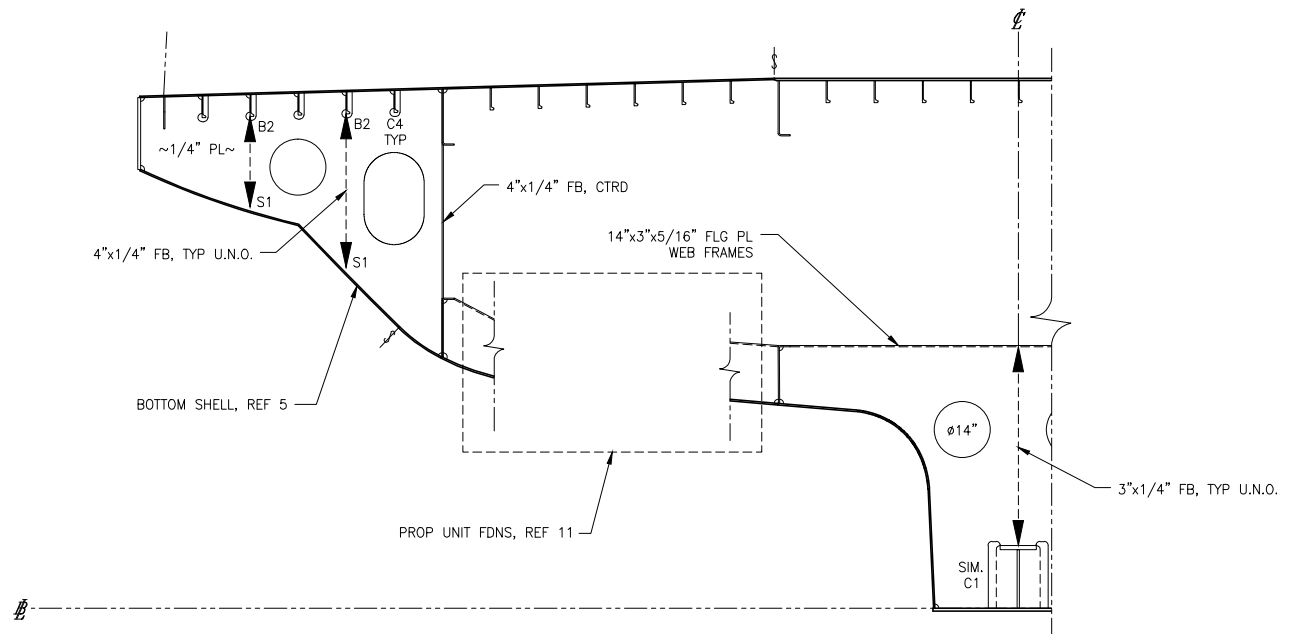

SECTION 2-2A
 FRAME 38, 'B' END
 LOOKING FWD: STBD SIM/OPP
 'A' END SIM/OPP



8/6/2018 11:05:55 AM

CONFIDENTIAL AND PROPRIETARY PROPERTY OF
EBDG - NC, PLLC
 MAY NOT BE USED FOR CONSTRUCTION OR PROVIDED TO
 ANY THIRD PARTIES WITHOUT PRIOR WRITTEN CONSENT.
 ©2018 ELLIOTT BAY DESIGN GROUP.

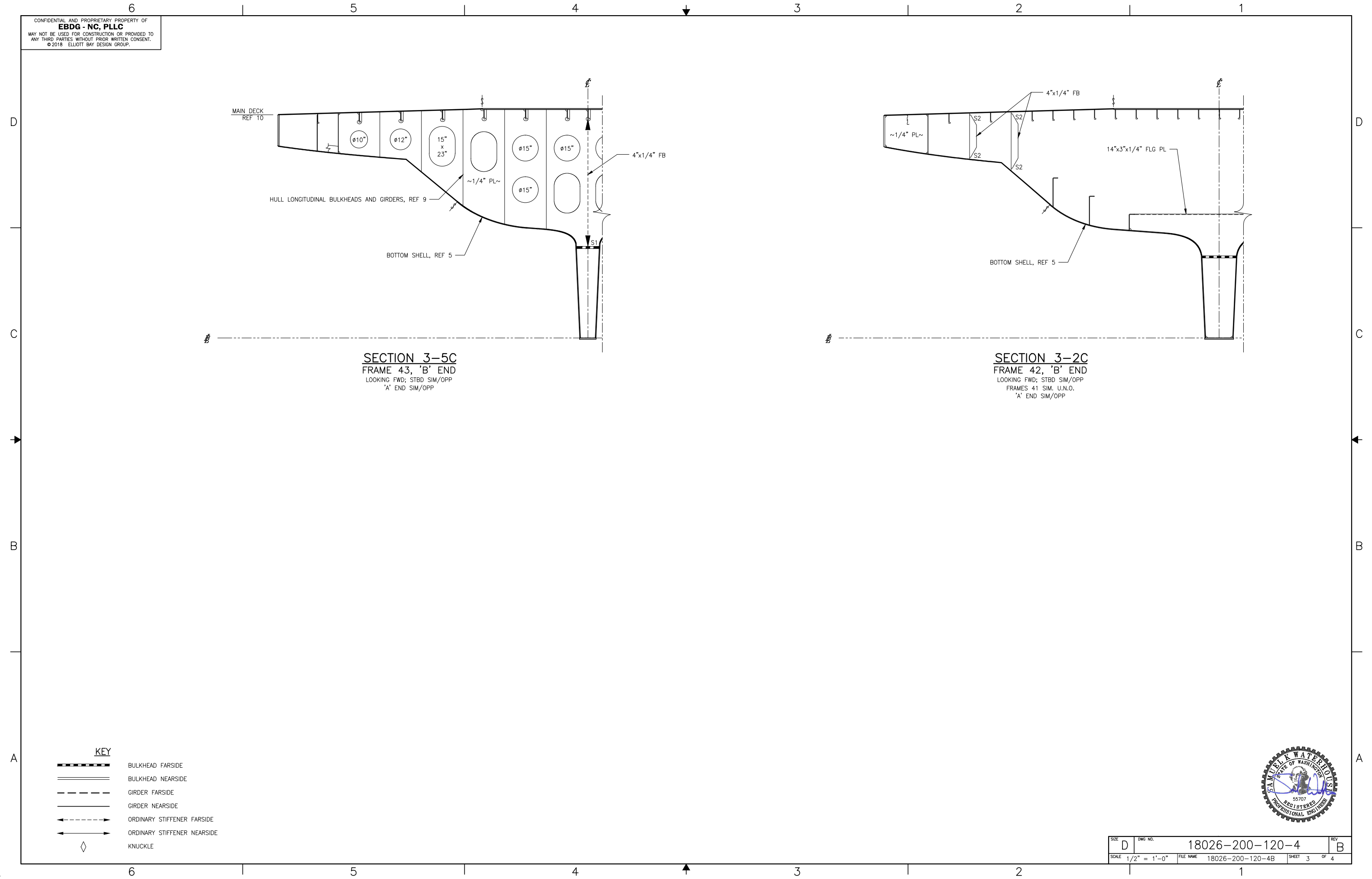

SECTION 3-5C
 FRAME 43, 'B' END
 LOOKING FWD; STBD SIM/OPP
 'A' END SIM/OPP

SECTION 3-2C
 FRAME 42, 'B' END
 LOOKING FWD; STBD SIM/OPP
 FRAMES 41 SIM. U.N.O.
 'A' END SIM/OPP

KEY

	BULKHEAD FAR SIDE
	BULKHEAD NEAR SIDE
	GIRDER FAR SIDE
	GIRDER NEAR SIDE
	ORDINARY STIFFENER FAR SIDE
	ORDINARY STIFFENER NEAR SIDE
	KNUCKLE



SIZE	D	DWG NO.	18026-200-120-4	REV	B
SCALE	1/2" = 1'-0"	FILE NAME	18026-200-120-4B	SHEET	3 OF 4

8/6/2018 11:06:00 AM

CONFIDENTIAL AND PROPRIETARY PROPERTY OF
EBDG - NC, PLLC
 MAY NOT BE USED FOR CONSTRUCTION OR PROVIDED TO
 ANY THIRD PARTIES WITHOUT PRIOR WRITTEN CONSENT.
 ©2018 ELLIOTT BAY DESIGN GROUP.

6

5

4

3

2

1

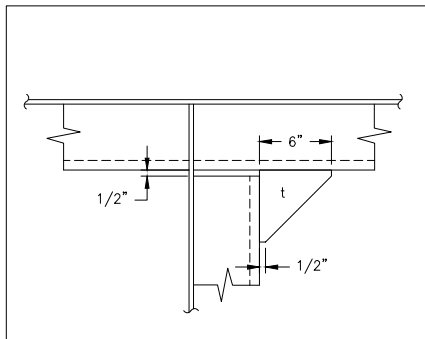

B2

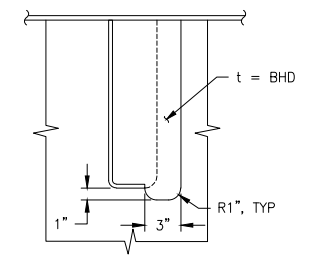

C1

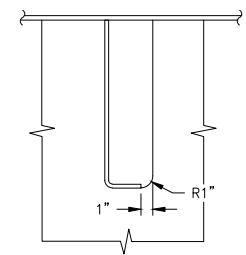

C2

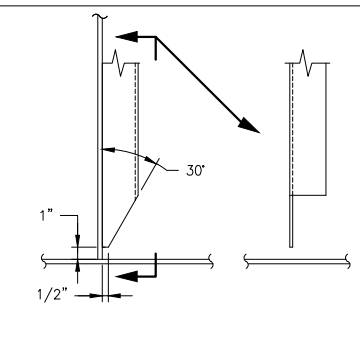

S1

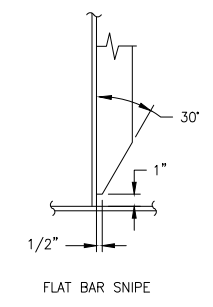

S2

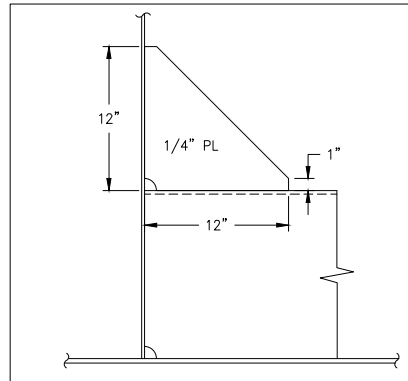

B3

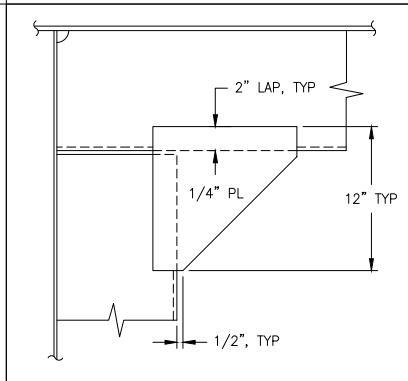

B4

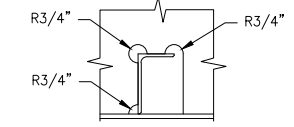

C3

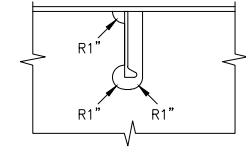

C4

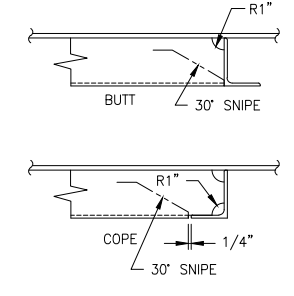

J1

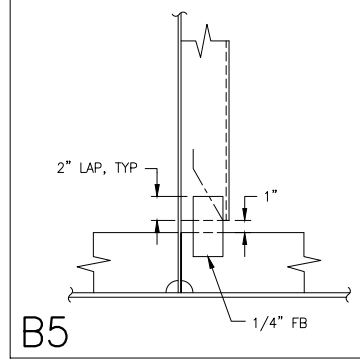

B5

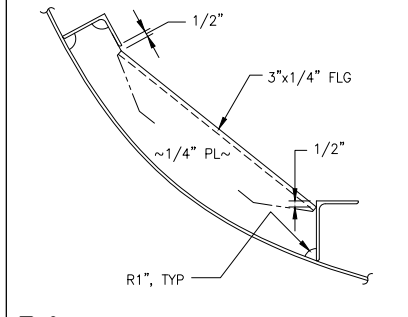

B9



SIZE	D	DWG NO.	18026-200-120-4	REV	B
SCALE	1 1/2" = 1'-0"	FILE NAME	18026-200-120-4B	SHEET	4 OF 4

6

5

4

3

2

1

8/6/2018 11:06:05 AM